



Three Shop-Built Router Tables



Router TABLE-MAT



Everything you'd want in a router table for just \$50 and a long weekend in your shop.

Commercially made router tables are everywhere these days. Some of them come with more gizmos and gadgets than a '59 Edsel. By the time you tally up all the add-ons, the price approaches a medium-duty shaper. Here's my short list of "must-have" features for a good router table:

- A table the size of a carrier deck.
- Compact design so it can store easily.
- A stout fence that's long and easy to adjust.
- Easy bit-height adjustment with no stooping.
- Great dust collection.
- A \$50 price tag.

With all these features in mind, I hit on the idea of using my folded-up Workmate stored under the stairs. Can't I just make a top for it? Then I remembered the great idea from Contributing Editor Nick Engler in our January 2000 issue. Nick made the top of his router table tilt up for easy adjustments. Bingo. Now my

Workmate/router table goes right back under the stairs and takes up only another 1½" of space, the thickness of the router tabletop. You can also use this router table without a Workmate. A simple pair of sawhorses will suffice.

Customizing Your Table

While the fence is generic to any router table setup, the table needs to be customized for your needs. You may have a different brand router than mine, so you will have to relieve the underside of the table to accommodate the shape of your tool. You'll have to locate the mounting holes for the base to suit your router. You may prefer a different table height. If you are below average height, you'll want to make the angle at which the table props up less steeply.

The top is made from two pieces of ¾" birch plywood that are glued together and band-

by Steve Shanesy

Comments or questions? Contact Steve at 513-531-2690 ext. 238
or SteveS@FWPubs.com.

Photo by Al Parrish

E



Cutaway view of the router base in the table

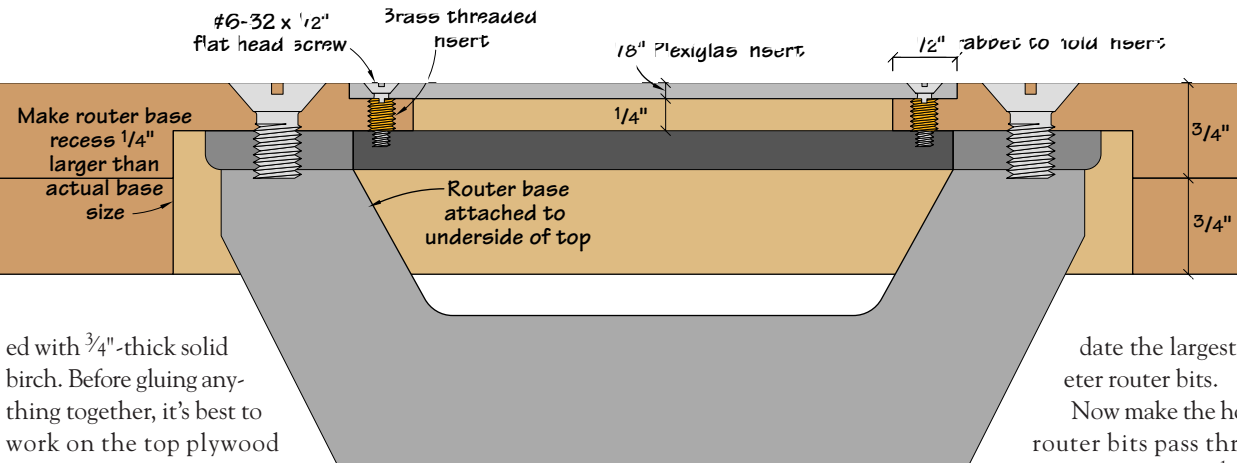

ed with $\frac{3}{4}$ "-thick solid birch. Before gluing anything together, it's best to work on the top plywood piece. Since you must rout out the underside of this top piece where the router base will be mounted, do it before gluing the two sheets together. The hole in the bottom sheet can be simply cut with a jigsaw.

First, lay out where you want your router base to be mounted and find the exact center of the base. I put the centerpoint on my table 8" in from the back edge and centered right to left. So once the point is established, drill a $\frac{1}{16}$ " hole straight through to the other side. You'll need this location for work later on.

Now set up a router with a circle-cutting jig and a $\frac{1}{2}$ " straight bit. Set the bit so it will cut to a depth that will leave a

$\frac{3}{8}$ " thickness in the plywood top. Cut a circle (assuming your router has a round base) on the underside of the top that is approximately $\frac{1}{4}$ " larger in diameter than the router base. Place the circle jig's indexing pin in the center hole you just drilled. Rout the circle and the remaining waste inside the circle.

Next, turn the plywood piece over. Use your center hole and circle jig to cut a $\frac{1}{8}$ "-deep circular rabbet or ledge for your plastic inserts to fit into. The insert diameter is $4\frac{3}{4}$ ". But before you use this insert size, check the size of your router's base. You may need to make a smaller-diameter insert based on the size of your router base. The router I mounted in the table is a massive Porter-Cable 7518. I made the insert hole size large enough to accommo-

date the largest diameter router bits.

Now make the hole the router bits pass through. Leave a ledge about $\frac{1}{2}$ " wide all around for the removable inserts to rest on.

Now take the second sheet of plywood and jigsaw the cut to accommodate the router base. Also, make any cuts necessary to allow for your router base's handles. When done, glue the two sheets together. Keep the edges flush.

When the glue is dry, trim the top to finished size on the table saw. Now prepare some stock for the solid-edge banding. Miter the corners and glue it on. Make sure it is flush to the top. When dry, sand everything flush, then rout a roundover profile on the top edge.

Tabletop Inserts

Make the round tabletop inserts from $\frac{1}{8}$ " acrylic. I made three inserts to cover most of the router bit sizes I'd encounter. First set the circle jig to cut a circle that is the same size as the insert hole. Set your router to make an outside cut instead of



A larger base for the router was the ticket for bridging the open areas left by routing out the plywood for the router's base. It was later used as a small circle cutting jig for the tabletop and plastic inserts. Use the same cutter and it's easy to keep track of dimensions for cutting inside or outside circles.



Make the round tabletop inserts from $\frac{1}{8}$ " acrylic. I made three inserts to cover most of the router bit sizes I'd encounter. First set the circle jig to cut a circle that is the same size as the insert hole. Set your router to make an outside cut instead of

ROUTER TABLE AND FENCE

No.	Ltr.	Item	Dimensions T W L	Material
2	A	Table top	$\frac{3}{4}$ " x 23" x 35"	birch ply
1	B	Top edge banding	$\frac{3}{4}$ " x $1\frac{1}{2}$ " x 11'	solid birch
1	C	Workmate board	$\frac{3}{4}$ " x 4" x $27\frac{3}{8}$ "	any hardwood
1	D	Prop stick	$\frac{3}{4}$ " x $18\frac{3}{4}$ "	dowel stock
1	E	Prop bracket	$\frac{1}{2}$ " x $1\frac{1}{2}$ " x 4"	Baltic birch
1	F	Fence bottom	$\frac{1}{2}$ " x 8" x 41"	Baltic birch
2	G	Fence sub fronts	$\frac{1}{2}$ " x 3" x $12\frac{1}{2}$ "	Baltic birch
2	H	Dust chute sides	$\frac{1}{2}$ " x $4\frac{1}{8}$ " x 8"	Baltic birch
1	I	Dust chute top	$\frac{1}{2}$ " x 4" x 5"	Baltic birch
1	J	Chute angled top	$\frac{1}{2}$ " x 5" x $4\frac{3}{4}$ "	Baltic birch
1	K	Chute back	$\frac{1}{2}$ " x 5" x 5"	Baltic birch
2	L	End ribs	$\frac{1}{2}$ " x $2\frac{5}{8}$ " x 3"	Baltic birch
2	M	Mid ribs	$\frac{1}{2}$ " x $2\frac{5}{8}$ " x $2\frac{5}{8}$ "	Baltic birch
2	N	Fence adjust. front	$\frac{3}{4}$ " x 4" x 16"	any hardwood

Hardware: 3, $\frac{6}{32}$ threaded inserts and $\frac{1}{2}$ " $\frac{6}{32}$ screws; 4 each $\frac{3}{8}$ " x $1\frac{1}{2}$ " round head machine screws, star washers, flat washers and wing nuts, 1 pr. medium-duty loose-pin hinges. Acrylic $\frac{1}{8}$ " sheet 12" square, 1 switched plug strip.

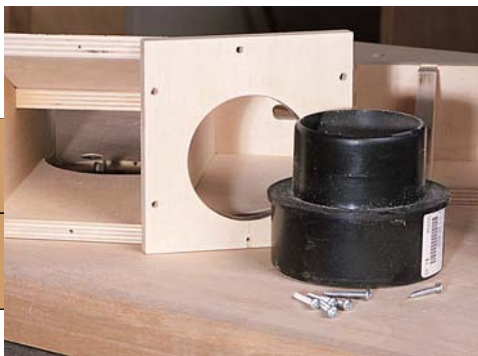

Inside view of the dust chute from the rear including the plastic 4" to 3" dust collection hose adapter. Rout the 3" hole for the adapter with the circle-cutting jig or use a "fly cutter" in your drill press.



As you assemble the fence, make sure it is square along its length. Be sure and check it again after it is clamped up.

an inside cut. To rout the acrylic, just drill a hole to accommodate the circle-cutting jig's pin or nail.

The three hole sizes I made in the inserts were 1", 1 $\frac{3}{4}$ " and 2 $\frac{3}{4}$ ". The smaller holes were drilled using hole saws but the larger size required the circle-cutting jig.

Complete the Top

To fasten the inserts to the table, install three threaded inserts in the rabbet. I used inserts for a 6/32 flush machine screw. Once installed, transfer their locations to the acrylic inserts, then drill and countersink the plastic.

Next make a new piece to replace the rear board on the Workmate's table. The homemade board is narrower and allows the router to swing up unencumbered. Cut the board to the dimensions given in the materials list and locate holes that match those in your existing Workmate. The new board is slightly shorter than the original. Install the Workmate connecting hardware and place the board in the furthest connecting hole of the Workmate.

On the underside of the router tabletop you'll need to install a piece of $\frac{1}{2}$ " material where the stick that supports the top in the open position locks in place. I used a $\frac{3}{4}$ " dowel for a prop stick and drilled an oversized hole on a 25° angle in the block to nest it.

As mentioned earlier, the length of the prop stick will depend on how tall you are. On the end of the stick opposite the 25° angle, drill two holes that intersect each other to allow the stick to pivot in two directions, side

to side so that it can be lowered when not in use and angled to allow you to tip it forward when propping the tabletop. Use a stout wood screw, a #10 or #12, to connect the prop stick to the edge of the new shop-made top board.

Next use a pair of hinges to connect the top to the Workmate's front board. Locate them about 4" in from each end.

Now Make the Fence

Keep in mind the most important factor in making the fence is that it is straight and square to the table. It could be shimmed later, but you'll be fussing with it forever.

Start by laying out the full size shape of the bottom piece on the material you will actually use. Be sure you have a true,

straight edge for what will be the front.

Go ahead and lay out where the dadoes will be cut, including where the half-round throat opening for the router will be. It's best to do the layout by first establishing the center of the length of the fence and working out from there. When done, cut the back shape. It need not be pretty.

Next cut out the two subfronts for the fence. Install your dado blade on the table saw to cut the thickness of the Baltic birch.

Now set the dado blades to make a $\frac{1}{8}$ "-deep cut. While holding the front edge of the fence bottom against the slot miter gauge, cut the six dadoes, following the layout lines already marked. When done, cut the center dado on the subfronts making sure it locates precisely where the dado in the bottom falls. Next raise the dado set to cut $\frac{3}{8}$ " deep and run the rabbets on the ends and bottom of the fence subfronts.

Remove the dado and cut the fence ribs and pieces that make up the dust collection chute. Use the diagram for the shape. Before assembling the fence, cut the half circle in the fence bottom for the throat opening, then use a rasp to slope the back edge for more efficient dust evacuation.

Assemble the Fence

Be careful when you assemble the fence to make sure it goes together square. First dry-fit all the parts to be sure you have a good fit. Then glue the ribs and dust chute sides to the

Once the tabletop is hinged to the Workmate's front board, it's easy to locate the positions for the prop stick and stick bracket. Note the shop-made replacement board for the Workmate top.





Break in your router table by milling the slots in the fence subfront that will allow the fence faces to adjust into or away from the router bit. Lay out the stop/start lines and plunge cut the slots.



Attach the fence faces using $\frac{3}{8}$ " roundhead machine screws, a star washer, flat washer and wing nut. I tried using hex-head bolts but switched to screws because a screwdriver can be used and makes a more secure attachment with less trouble.

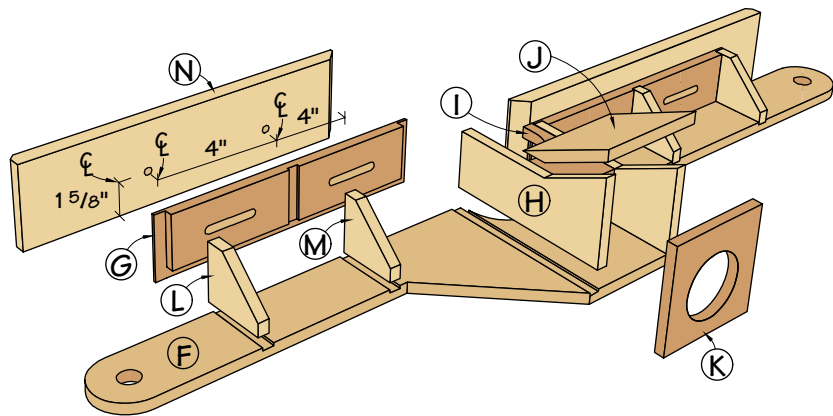

bottom, making sure all the edges are flush to the front edge. If you have a brad nailer, set these in place with a couple short brads. Glue the fence subfronts to the bottom and ribs. Clamp front to back until the glue dries.

Now cut the three remaining dust chute parts: the top, angled top and back. Cut a half circle in the top similar to the one in the fence bottom. After the glue in the fence assembly has dried, glue the dust chute top in place. Afterwards, install the angled top and the back piece. The angled top requires a steep angle cut on the lower edge to seat down to the flat top. I cut this angle on my band saw. The back of the chute requires a hole for dust collection. The chute is set up to take a 3"

hose or a fitting that reduces a 4" hose to a 3" hose. I used a "fly cutter" in my drill press to make the 3" hole. To complete the assembly of the dust chute, screw the angled top, then the back in place.

Use Your New Router Table

Now use your router table to mill the slots in the fence's subfronts that allow the fence fronts to slide left to right.

Set your router in the table with a $\frac{3}{8}$ " straight bit. Make a temporary fence from a straight piece of scrap and clamp it to the tabletop. Use the fence diagram for setting the distance. Cut the 2"-long slots in the center of the openings between the ribs.

Make the adjustable fronts from a tight-grained hardwood such as maple. Be sure the material is flat and straight. Cut the two pieces to the lengths given. Make

bevel cuts on the ends as shown in the diagram. Carefully locate the hole locations where the $\frac{3}{8}$ " machine screws attach the fronts through the slots in the subfronts. Drill and countersink the holes. For attachment, I used the screws along with star washers, flat washers and wing nuts.

The last detail is to cut a small piece of acrylic as a "window" on the top of the dust chute into the router opening area below. **PW**

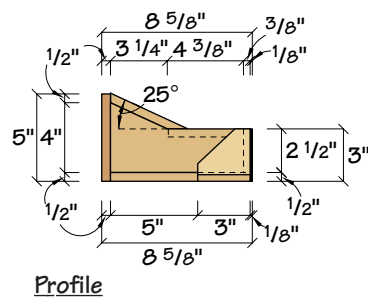
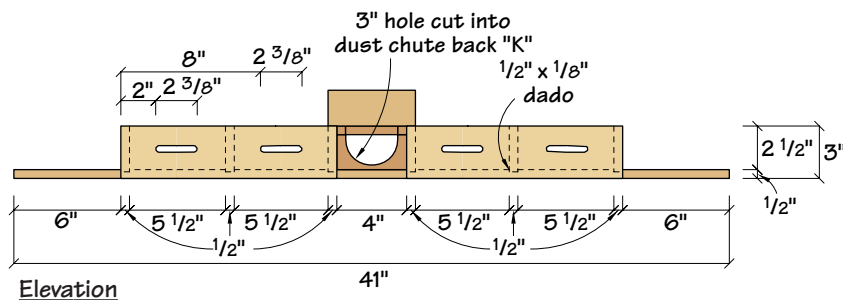
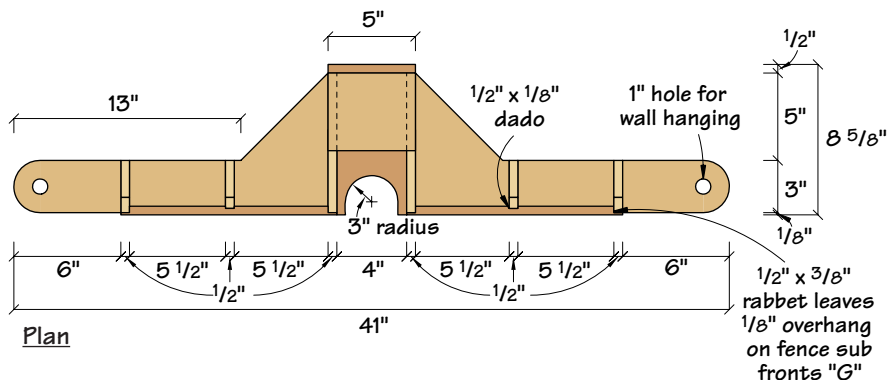



Photo by Al Parrish

The Joint Maker

This horizontal router jig has a table that slides in four directions, turning a router into a joint-making monster.

by Nick Engler

Nick Engler, the author of more than 50 books on woodworking, has built a replica of the 1903 Wright Flyer, the first true airplane, and is now working on the 1905 Flyer.

This horizontal routing jig, which I call “Joint Maker,” holds the router to one side of the work. This setup offers several advantages over a standard router table for certain operations:

- You have more control when making mortises – you can rest the part on its face and feed the edge into the bit.
- When making tenons, the rotation of the bit doesn’t pull the work sideways as it does on an ordinary router table. Instead, you cut directly against the rotation.
- And if you use vertical panel-raising bits, you’ll find that with the panel resting flat on the worktable, gravity works for you.

I've built several Joint Makers throughout the years and I've noticed that the most serious limitation encountered is in routing small, narrow parts – your hands come too close to the bit for safe, accurate control. So I added a carriage on this one – essentially it's a sliding table. It works wonderfully. Just clamp the workpiece to the carriage and use it to feed the work into the router bit. Four stops on the carriage help position the work and control the cut. A unique cross slide keeps the work perfectly aligned with the bit, yet allows you to feed it front-to-back and side-to-side.

How Do I Build It?

In essence, the Joint Maker is just a Baltic birch plywood box with two flat work surfaces – one vertical, one horizontal – mounted to it. The vertical surface (or router mount) is attached to the back of the box and holds the router. The horizontal surface (or carriage) slides over the top of the box and holds the work.

Cut the parts to the sizes given in the cutting list. Rout $\frac{3}{4}$ "-wide x $\frac{1}{4}$ "-deep grooves in the top surface of the top and the bottom surface of the carriage, as shown

in the illustrations on page 81. Note that the grooves in the top run front-to-back, while those in the carriage run side-to-side. The grooves fit around the cross slides.

Cut the shape of the top and cross-slide mount. The top has a "fixed stop" on one side and a cutout in the other.

Then cut a $2\frac{1}{4}$ "-diameter dust-collection hole in one of the end pieces. Next, you should drill a $\frac{5}{16}$ "-diameter pivot hole for the router mount in the back side.

Assemble the bottom, sides, ends and baffle (which is a dust-collector diverter) with glue and screws. Insert the carriage bolt that serves as the pivot for the router mount through the pivot hole in the back side, then screw the top in place. But don't glue the top to the assembly – I found that out the hard way. If the pivot bolt happens to fall out, you can lose your religion trying to get it back in. (Of course, had I been smart, I would have epoxied the bolt in place.)

Mounting the Router

Attach the router to a clear plastic plate before putting it in the router mount. Because this router mounting plate is thinner than

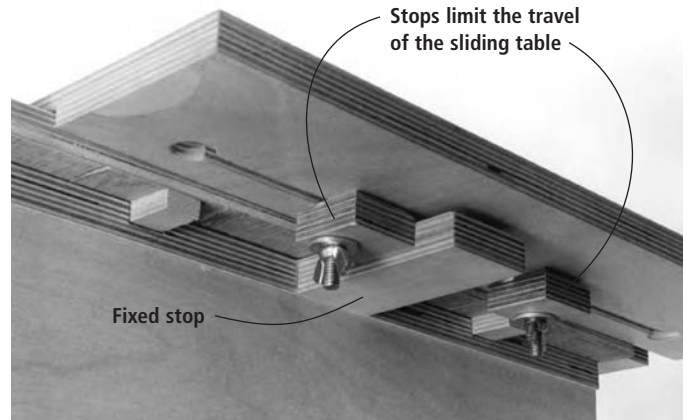

The sliding carriage has several straight slots with a $\frac{3}{4}$ "-diameter hole at one end for you to mount the stops without having to remove the hardware. Just insert the head of the mounting bolt in the hole and slide the stop in.

the board it attaches to, this arrangement gives you a fraction of an inch more depth of cut. More importantly, it lets you see what the router is doing as you cut.

To attach the plastic plate to the router mount, make a cutout and rabbet the edge to accept the mounting plate. Attach the router mounting plate to the router mount with #10 flathead sheet-metal screws. When installed, the router mounting plate must be flush with the work surface of

the router mount. The heads of the screws must be countersunk in the mounting plate so they rest slightly below the surface.

Cutting the Slots

There are two types of slots in this fixture. The carriage has several keyhole slots – straight slots with a $\frac{3}{4}$ "-diameter hole at one end. The holes let you mount the stops and clamps instantly, without having to remove the hardware. Just insert the heads of the mount-

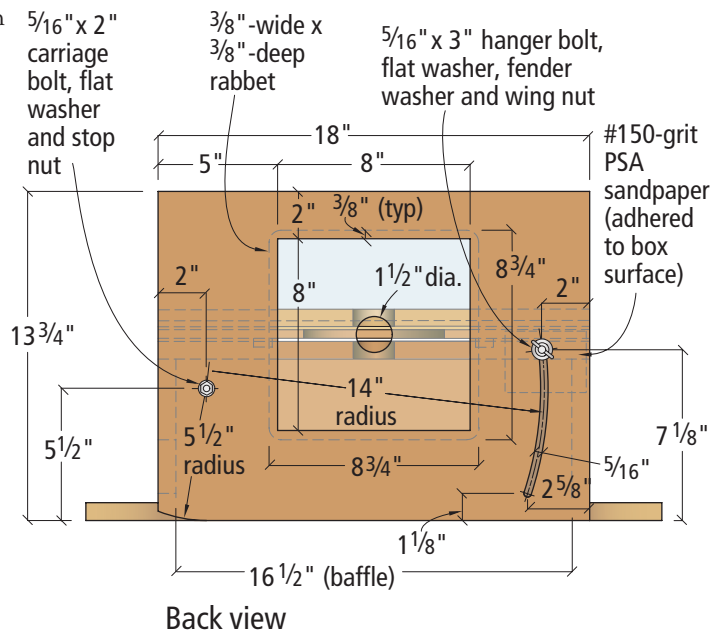
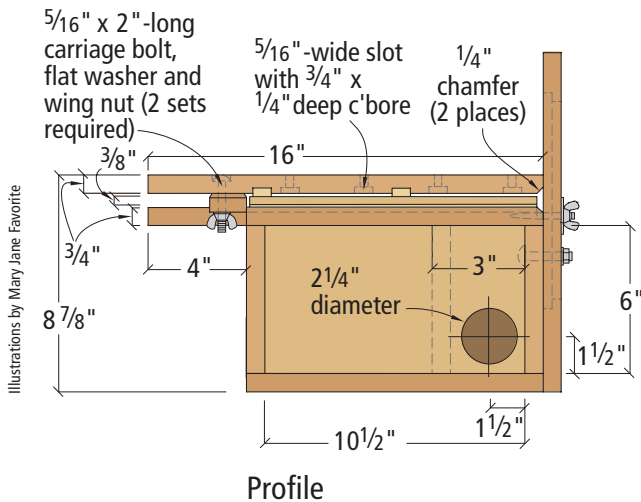

Illustrations by Mary Jane Favorite

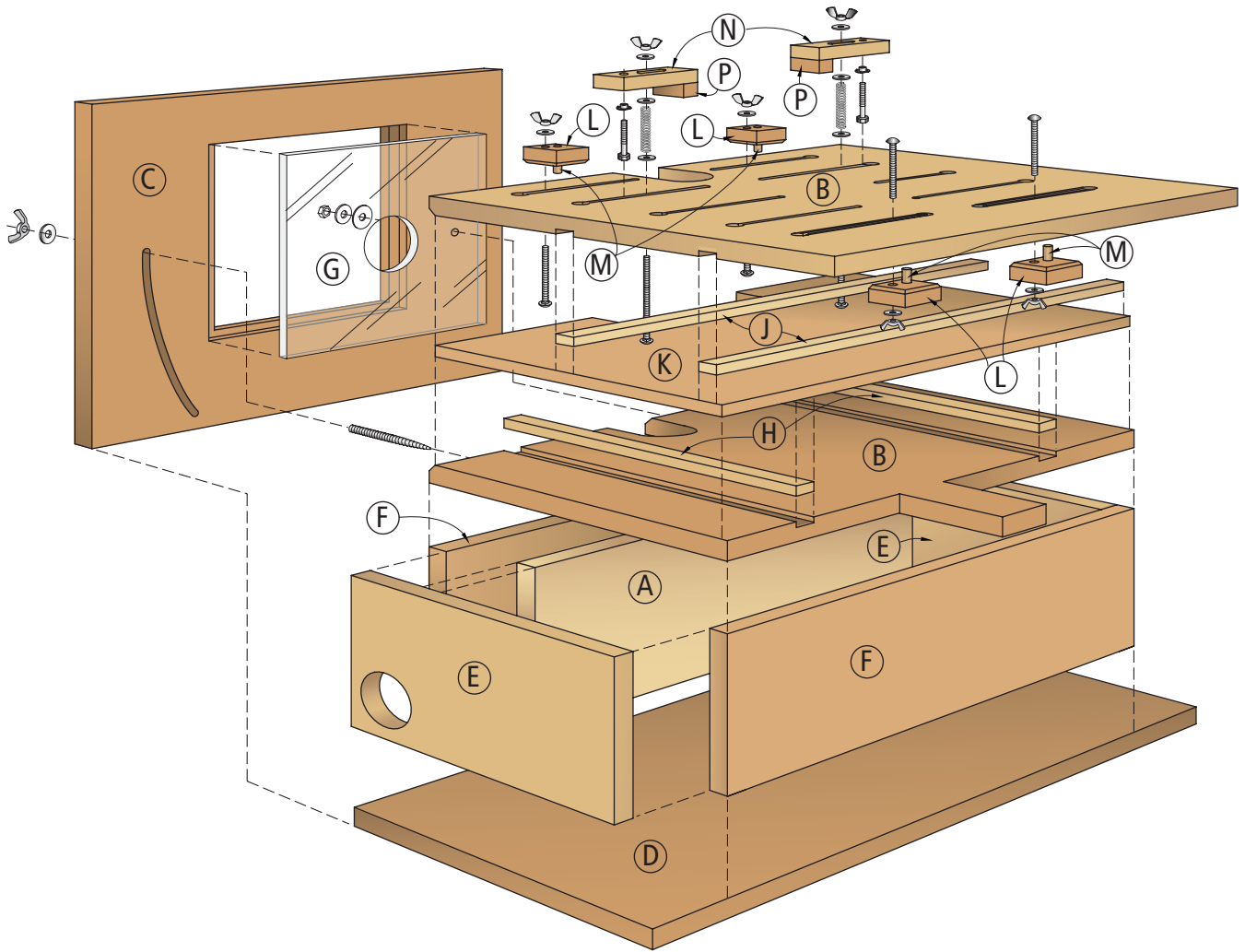

Exploded view

THE JOINT MAKER

NO.	LET.	ITEM	DIMENSIONS (IN INCHES)			COMMENTS	HARDWARE	
			T	W	L			
□	1	A	Baffle	$\frac{3}{4}$	6	$16\frac{1}{2}$	Baltic birch plywood	□ $\frac{5}{16}$ " x 2" carriage bolts (6)
□	2	B	Top/carriage	$\frac{3}{4}$	16	18	Baltic birch plywood	□ $\frac{5}{16}$ " x 5" carriage bolts (3)
□	1	C	Router mount	$\frac{3}{4}$	$13\frac{3}{4}$	18	Baltic birch plywood	□ $\frac{5}{16}$ " flat washers (15)
□	1	D	Bottom	$\frac{3}{4}$	12	24	Baltic birch plywood	□ $\frac{5}{16}$ " wing nuts (8)
□	2	E	Ends	$\frac{3}{4}$	6	$10\frac{1}{2}$	Baltic birch plywood	□ $\frac{5}{16}$ " fender washer
□	2	F	Sides	$\frac{3}{4}$	6	18	Baltic birch plywood	□ $\frac{5}{16}$ " stop nut
□	1	G	Router mounting plate	$\frac{3}{8}$	$8\frac{3}{4}$	$8\frac{3}{4}$	Acrylic plastic	□ $\frac{5}{16}$ " x 3" hanger bolt
□	2	H	Front-to-back slides	$\frac{1}{4}$	$\frac{3}{4}$	$11\frac{3}{4}$	Baltic birch plywood	□ #10 x $\frac{3}{4}$ " flathead sheet metal screws (8) & nuts
□	2	J	Side-to-side slides	$\frac{1}{4}$	$\frac{3}{4}$	18	Baltic birch plywood	□ #12 x $1\frac{1}{2}$ " flathead wood screw
□	1	K	Cross-slide mount	$\frac{1}{4}$	$11\frac{3}{4}$	18	Baltic birch plywood	□ compression springs (3)
□	4	L	Stops	$\frac{3}{4}$	$1\frac{1}{2}$	$1\frac{1}{2}$	Hardwood	□ 0.030 wire x $1\frac{1}{32}$ " I.D. x 5" long
□	4	M	Stop pins			1	$\frac{5}{16}$ " diameter	□ #8 x $1\frac{3}{4}$ " flathead wood screws (45)
□	3	N	Clamps	$\frac{3}{4}$	2	$5\frac{3}{4}$	Baltic birch plywood	□ $\frac{5}{16}$ " x 4" full-thread hex bolts (3)
□	3	P	Clamp jaws	$\frac{3}{4}$	$\frac{3}{4}$	2	Baltic birch plywood	□ $\frac{5}{16}$ " T-nuts (3)

You can make a counterbored slot in two steps. First rout the wide "counterbore groove" that forms the step inside the slots.

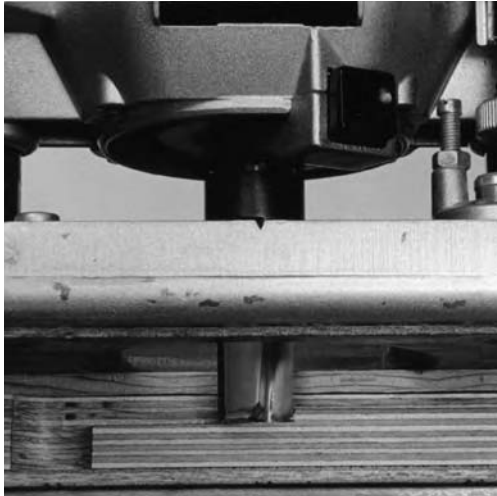

Then rout a slot down the middle of the groove, cutting completely through the stock in four 1/8"-deep passes.

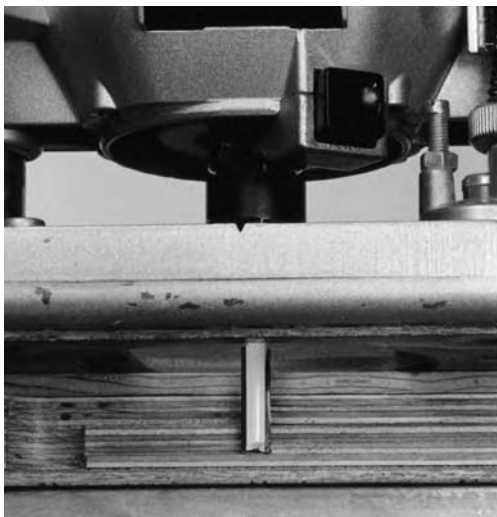

ing bolts in the holes and slide the stop sideways in the slot.

The slots let you position the stops and clamps wherever you need them when making cuts. Note that these slots are counterbored, which helps hold the heads of the bolts so they don't rub on the top of the fixture.

To make the keyhole slots, drill the 3/4"-diameter holes first. Then rout 3/4"-wide x 1/4"-deep counterbore grooves using a straightedge as a guide. Without changing the position on the router guide, change bits and rout a 5/16"-wide slot through the middle of each groove.

The other slot used in this Joint Maker is the curved slot in the router mount. To rout this slot, attach the router to a router compass jig. Insert a pivot bolt through the compass and the mount, then swing the router in an arc as you cut.

Make the Cross-slide Mount

The cross-slide mount is a simple assembly, but you have to get all four of the slides positioned correctly for it to work well. The best way I found to do this was to

use the tool itself as a glue-up jig.

Place a single layer of thin plastic in the grooves in both the top and the carriage (a plastic grocery bag works well). Then press the slides into their grooves on top of the plastic. Apply a thin bead of glue to the exposed surface of each slide. Place the cross-slide mount on top of the slides in the top, then place the carriage (with the slides in place) on top of it. Don't worry if there's glue squeeze-out; the plastic will prevent it from accidentally bonding surfaces that shouldn't.

Make sure everything lines up properly and the back edge of the carriage is flush with the back of the Joint Maker. Then clamp the parts together and let the glue dry. After it sets, take the carriage, cross slide and Joint Maker apart, and trash the plastic.

Make the Stops and Clamps

The stops and clamps are all attached to the carriage by carriage bolts. The stops are just blocks of wood with dowels protruding from the underside to keep them from rotating while in use. Chamfers around the bottom edges prevent

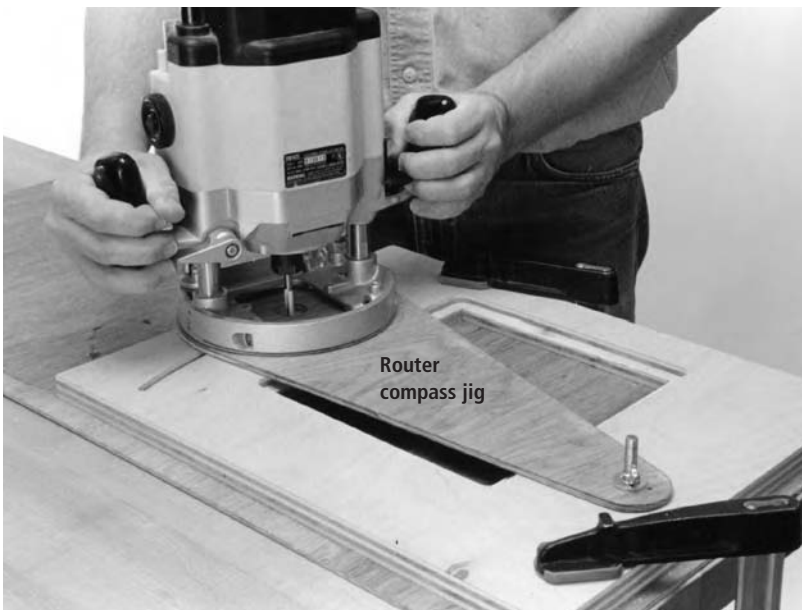

Router compass jig

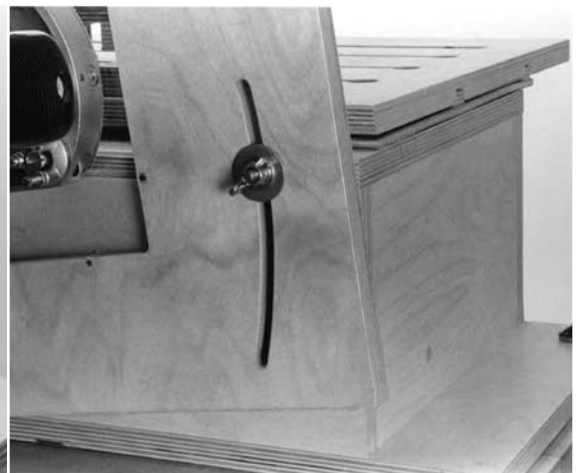

To rout the curved slot in the router mount, first make a router compass jig to guide your router in an arc. Drill the 5/16"-diameter mounting hole in the router mount and mark the ends of the curved slot. Use the mounting hole as the pivot and swing the router in an arc to cut the slot.

sawdust from interfering with the accuracy of your setup.

I found that as sawdust builds up around the stops, it prevents the parts from making full contact. This, in turn, keeps you from positioning the parts correctly. The chamfers give the sawdust somewhere to go. You will still have to brush the dust away from time to time, but you don't have to get every little particle.

On the clamps, a compression spring around the mounting bolt automatically raises the clamp when you loosen the knob. A hex bolt threaded into a T-nut at the back of the clamp prevents the assembly from tipping when you apply pressure.

Make as many clamps and stops as you think you'll need. I made just three clamps and four stops, which I've found to be ad-

equate for the work I do. But if you think you'll need more, now is the time to make them.

As another option (if you've got a few extra dollars) there are a couple of hold-down clamps available from catalogs that will also work very well when attached to the Joint Maker (see "Some Store-bought Options to Improve the Joint Maker" on page 82 for more information).

Final Assembly, Finishing

Give all the wooden surfaces a light sanding, then apply a durable finish to all parts of the Joint Maker: the router mount, carriage, cross slide, clamps and stops.

Apply a thin coat to all exposed surfaces, then rub down those surfaces that will slide together (such as the back and the router mount, or the top and the cross slide) with steel wool or fine

Countersunk pilot hole for #12 x 1 1/2" long flathead wood screw

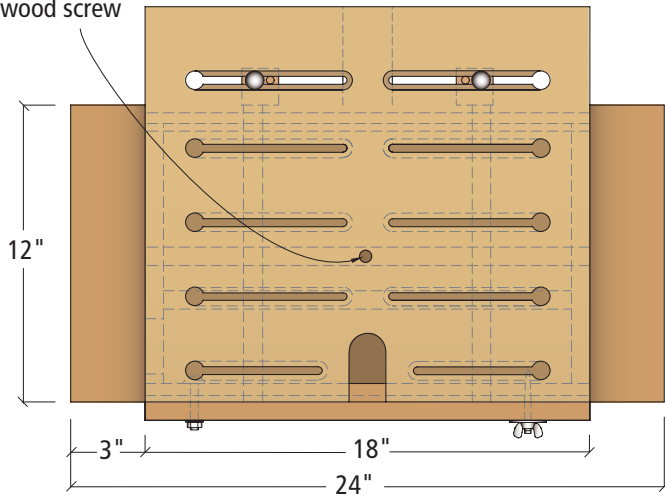

Carriage layout - plan

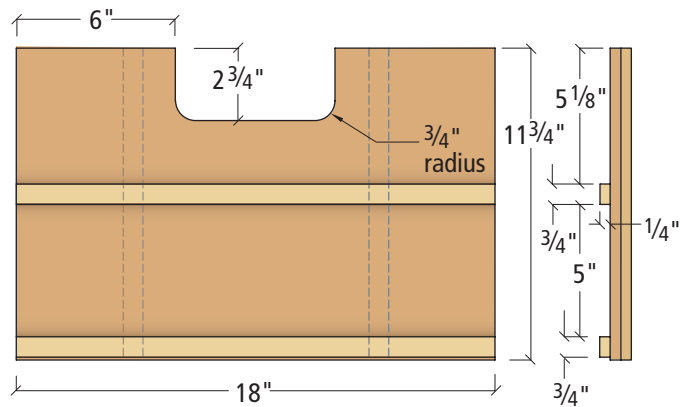

Cross-slide layout - plan

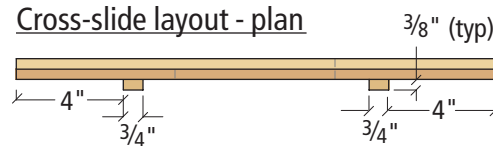

Cross-slide layout - profile

Cross-slide layout - elevation

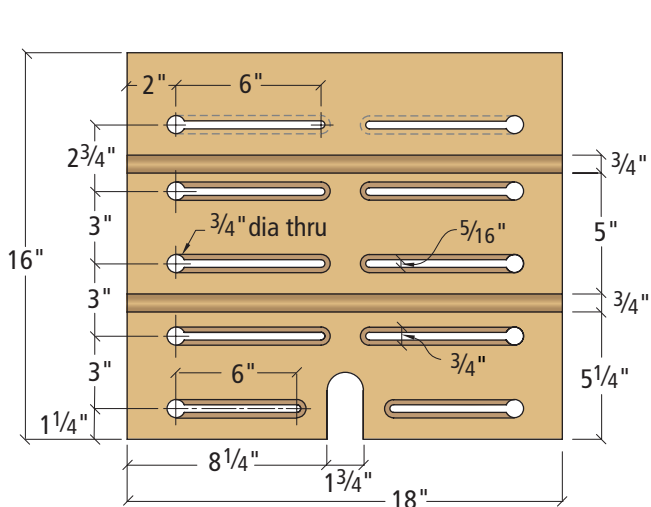

Carriage layout - bottom view

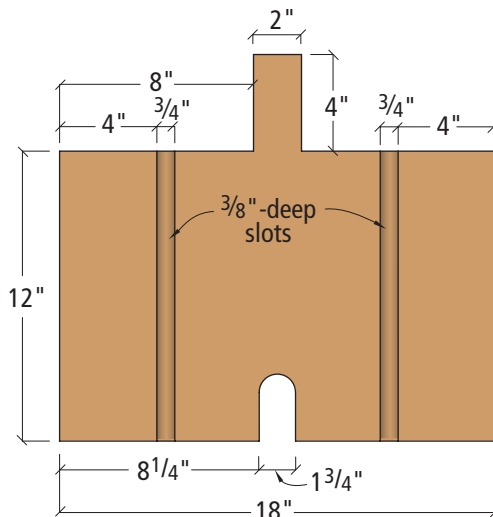

Top layout - plan

abrasive pads. Then apply a coat of paste furniture wax to the sliding surfaces of the top, cross slide and carriage, and buff it out. The thin layer of wax lubricates the surfaces and helps the parts slide much more easily.

Attach the router mount to the Joint Maker with a pivot bolt, washer and a stop nut. Using the curved slot as a guide, drill a $\frac{1}{4}$ "-diameter pilot hole for the hanger bolt in the edge of the top. Install the hanger bolt, fender washer, flat washer and wing nut, as shown in the illustrations.

Also install the hardware in the stops and clamps. The carriage and cross slide are not attached; they simply rest atop and slide on the Joint Maker.

Once you've done that, you're ready to test it out on all your joint-making operations. **PW**

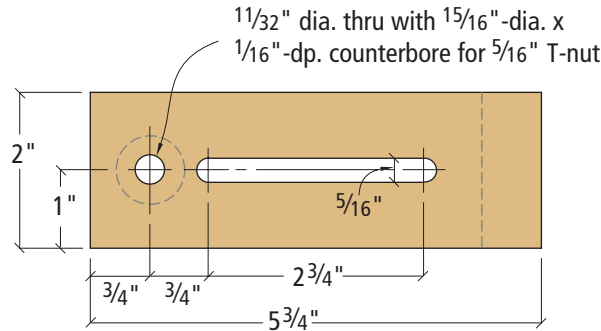

Clamp detail - plan

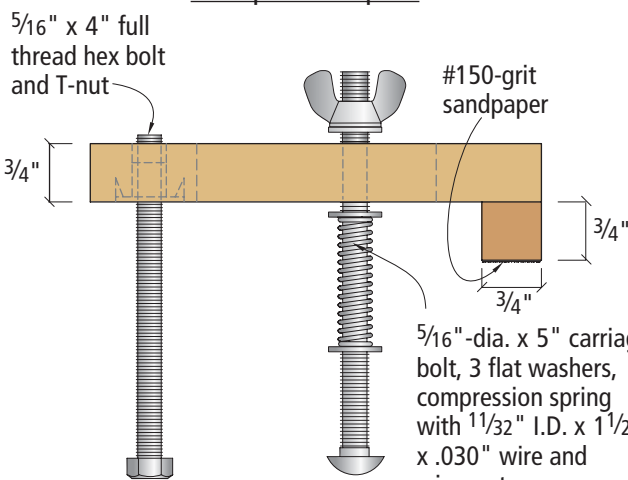

Clamp detail - profile

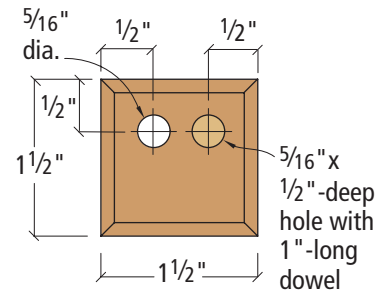

Stop detail - plan

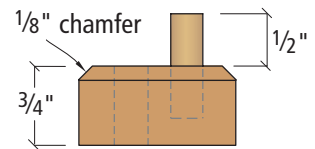

Stop detail - elevation

SOME STORE-BOUGHT OPTIONS TO IMPROVE THE JOINT MAKER

When we had a chance to work with the Joint Maker in the *Popular Woodworking* shop, we were definitely impressed with the cleverness of the design. Our minds were spinning with the amazing number of operations that could be performed easily with this homemade jig.

We also let our minds wander a little further about some of the features of the jig. After adjusting the numerous wing nuts (especially when applying hold-down torque to such a small surface area), we decided that some very affordable handles would make the jig more user-friendly. T-handle, star and three-wing knobs are available for 50 cents to \$2 each, and make gripping and tightening the adjusters a whole heck of a lot easier.

Another addition we felt would be useful were some optional manufactured hold-downs. While Nick's hold-downs function well, there are a number of other hold-downs available for less than \$5 that offer slightly better performance. The store-bought hold-downs shown at right will work with the slots as shown in the plans, and by purchasing them you'll reduce the

time necessary to build the jig and get you using it more quickly.

Both the knobs and hold downs shown here are available from Hartville Tool (800-345-2396 or hartvilletool.com). The knobs (right) are made from recycled plastic and available as two-prong (item #60936), three-prong (item #60866) or four-prong (item #60796). Each

costs 89 cents. The hold-down unit below left (item #60736) costs \$3.99 and includes a solid aluminum hold-down, a bolt and a $\frac{1}{4}$ "-20 knob.

— David Thiel



While the four-prong "star" knobs are easiest to grab, the two-prong "T" knobs require less clearance. The hold-down at left also works in the Joint Maker's slots.

USING THE JOINT MAKER TO CREATE A HAUNCHED MORTISE-AND-TENON JOINT



1 You can cut grooves on the inside of edges of rails and stiles with a straight bit. Lock the carriage to the base with a wood screw and feed the parts past the bit, guiding them along the mount.

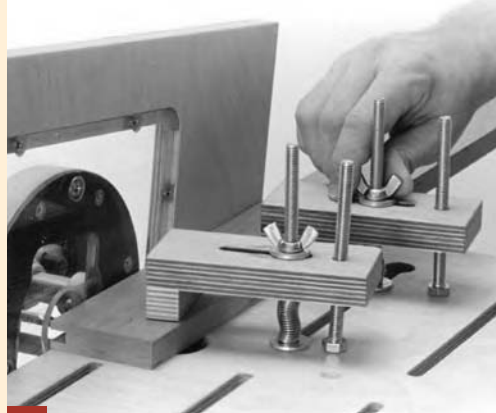

2 To cut the mortise, clamp a stile to the carriage so the inside edge faces the router. Adjust the hex bolts so the clamp jaws sit squarely on the work while you tighten the knobs.

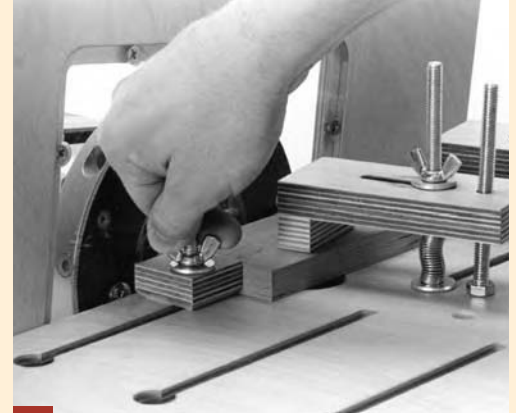

3 Secure a stop against the end of the stile to quickly align the other stiles. This makes it a lot easier to make the same cut in multiple pieces without having to set it up each time.



4 Advance the router bit to cut the full depth of the mortise. Holding the carriage, feed the stock into the bit no more than $\frac{1}{8}$ " deep at a time, moving it side to side.

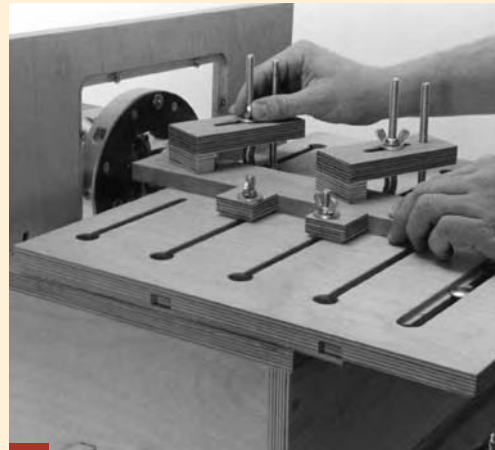

5 For the tenon, mount a rail on the carriage so the edge is perpendicular to the mounting plate. Secure stops against the rail to help you position the others for duplicate cuts.

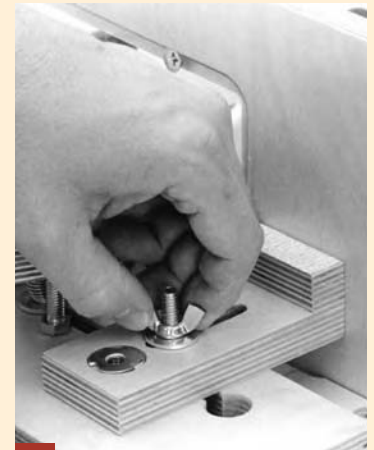

6 You can use the wooden clamp as a stop to prevent the bit from cutting into the carriage as you work.

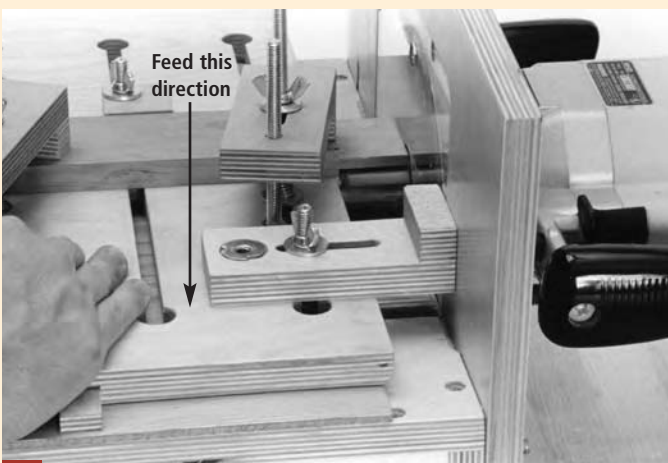

7 Once you set up the stops and clamps to cut the tenons just as you want them, feed the rail across the bit, cutting the underside of the stock. With the cutter below the work, you need to pull the work toward you to cut against the rotation of the bit.

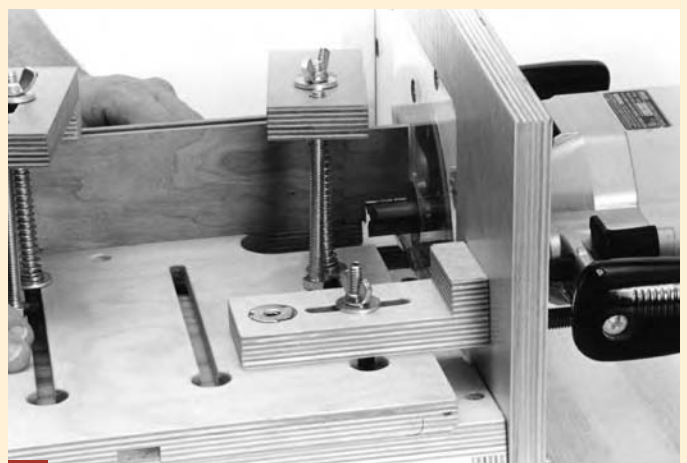

8 To cut the tenon's shoulders, turn the rail so the outside edge rests on the shoulders of the carriage and clamp it in place. Readjust the router bit and cut the haunch in the tenon, using the carriage to feed the work and control the cut.

ONE-WEEKEND Router Table

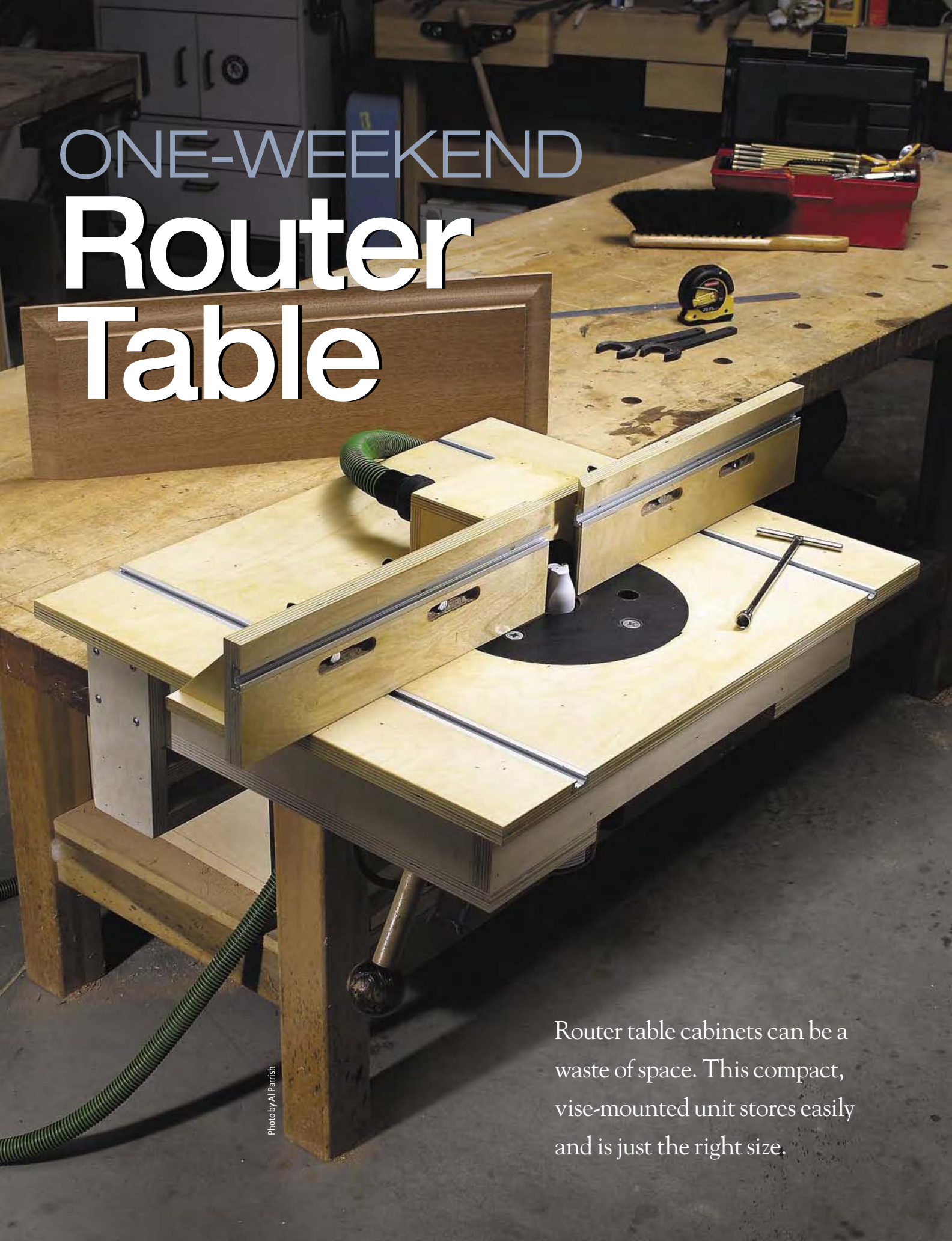

Photo by Al Parrish

Router table cabinets can be a waste of space. This compact, vise-mounted unit stores easily and is just the right size.

I think it might have been seeing a \$1,000 router table setup at a recent woodworking show (it's very cool, but \$1,000!). Or maybe it was realizing that our shop's router table's cabinet mostly takes up space and fills with dust. Either of these observations was enough to get us rethinking our router table needs.

Essentially you need a stable, flat working surface that can support most work. You need a fence that guides, supports and moves easily for adjustments (both the fence location on the table and the faces themselves toward the bit). You also need easy access to the router for bit changing and height adjustment. Other than that, it just needs to be up off the floor, hence the cabinet.

So we decided that a lightweight, easily stored router tabletop that would still offer all these benefits would be preferable. Oh, and we wanted to be able to make it in a weekend for less than \$120. No problem! The hardware came to \$65 and change. You can purchase the plywood locally or we've included a source on page 73 that will provide the necessary wood for less than \$50.

An Ingenious Design

For a stable, lightweight top the solution that made sense was a torsion box made of high-density plywood. The size that seemed most functional was a 20"-deep x 24"-wide platform that only needed to be about 4" tall. The box itself has an open center section on the bottom to accommodate the router body. There are two lengths of T-

track installed front to back on the tabletop to easily reposition the fence.

The fence itself is a variation of one we've built half-a-dozen times. The fence base is almost a torsion box – more of a torsion corner – that provides stable support for the laterally adjustable fence faces and allows for dust hook-up.

For the router itself, we went shopping. After looking at a number of router lifts and router table plates we chose the Milwaukee 5625-29, a 3½ horsepower router that offers through-the-base height adjustment. And, no, the price of the router is not included in the \$120 figure. You don't have to use this router, but in our opinion it has the horsepower you want to swing large panel-raising bits on your router table, and the through-the-base adjustment means you don't need to buy a router lift. The variable speed is also a big plus.

We chose a circular router plate from Veritas because it replaces the sole plate on your router and allows you to still use the router freehand or in the table without changing the base. The base also fits into the table without the use of any tools, and slips in and out from above in seconds.

Now the fun part: To bring the router table up to height, but still make it compact, we designed a brace that is mounted to the table and then the entire thing is simply clamped in your bench vise. Instant router table!



Allowing the proper clearance for your router is critical. You can see that I've removed the handles from the tool to allow as much space as possible. Mark out the space and then assemble the frame to fit.

Torsion Top Construction

The top itself is very simple to make. A frame made of ¾" x 3" plywood pieces is sandwiched between two pieces of ¾" plywood. The bottom piece is notched to accommodate your router (you'll need to test fit your router to locate the center frame pieces and the notch). The top piece extends 1½" beyond the frame on all sides to allow for clamping featherboards or other guides to the top surface.

Start by cutting out the top, bottom and seven frame pieces. If you opt to use the Veritas plate, the instructions are very clear on

how to cut the hole in the tabletop to fit the plate. Otherwise, follow the instructions for your individual router plate.

We chose to locate the router plate closer to the front of the table rather than in the center of the table. Most router table work happens within 6" of the fence and this location keeps you from having to lean across the table for operations. If you have a larger piece to run, the fence can be reversed on the table to give you a larger support surface.

With the router plate located in the top, suspend the router from the top and locate the two center frame members the necessary distance to clear the router. Make a note of that dimension, then lay out your frame accordingly.

by David Thiel

Comments or questions? Contact David at 513-531-2690 ext. 1255
or david.thiel@fwpubs.com

I used glue and an 18-gauge brad nailer to assemble all the pieces for this project. While perhaps not the height of joinery, it's fast and reliable.

With the frame assembled, place the frame on the bottom, and mark and notch the center section to allow clearance space for the router body. You could leave the center section open, but the extra strength along the back of the tabletop is worth the effort.

Attach the bottom the same way you assembled the frame.

Before fastening the top to the table, you need to install the aluminum T-track inserts for fence adjustment. I used a dado set on my table saw to run the grooves before attaching the top.

Next, attach the top, centering it on the frame assembly. Pay extra attention when attaching the top to keep the fasteners below the surface of the tabletop.

This will keep you from scratching your work, or worse, allowing your wood to hang up on a brad head during an operation.

Down and Dirty Fence

The fence is also absurdly simple to make. Accuracy is important to make sure it sits square to the tabletop, but other than that, it's brads and glue.

Start construction on the fence by cutting out the base, sub-

face, faces and braces. All but the braces are very straightforward. The braces are actually triangles. The best method is to rip a piece of plywood to 3" wide, then head to the miter saw. First miter both ends of the strip at a 45° angle, then reset the miter saw for a 90° cut and cut the 3" triangles from the strip. Repeat this process and you've got four braces.

The sub-face and base need to have a 3"-wide half-circle cut at



More marking: With the frame assembled and resting on the bottom piece, mark out the notch that will allow the router to extend through the top.

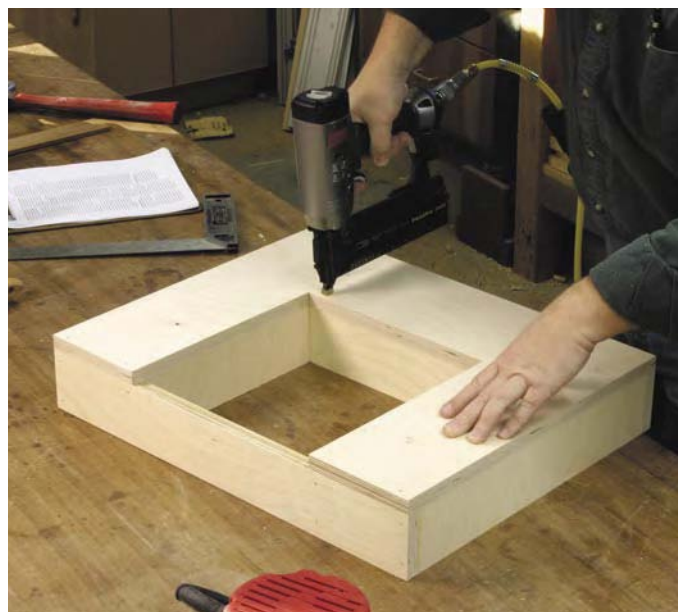

With the bottom notched, simply glue and nail it in place on the frame.

ONE-WEEKEND ROUTER TABLE

NO.	LET.	ITEM	DIMENSIONS (INCHES)			MATERIAL
			T	W	L	
□	1	T1 Top	3/4	20	24	Plywood
□	1	B1 Bottom	3/4	17	21	Plywood
□	2	B2 Frame F&B	3/4	3	21	Plywood
□	4	B3 Frame dividers	3/4	3	15 1/2	Plywood
□	1	B4 Frame divider	3/4	3	10 1/2	Plywood
□	2	B5 Support stems	3/4	3	7	Plywood
□	2	B6 Support braces	3/4	3	21	Plywood
□	2	F1 Fence faces	3/4	4	14	Plywood
□	1	F2 Fence sub-face	1/2	3 1/2	28	Plywood
□	1	F3 Fence base	1/2	3	28	Plywood
□	4	F4 Fence braces	3/4	3	3	Plywood
□	1	F5 Hood top	1/2	5	3 1/2	Plywood
□	2	F6 Hood sides	1/2	2 1/2	3	Plywood
□	1	F7 Hood back	1/2	5	3	Plywood
□	2	H1 Fence T-tracks	3/8	3/4	14	Aluminum
□	4	H2 Hex-head bolts	1/4"-20	1 1/2"		
□	4	H3 Star knobs				
□	2	H4 Cam clamps				
□	2	H5 Table T-tracks	3/8	3/4	20	Aluminum

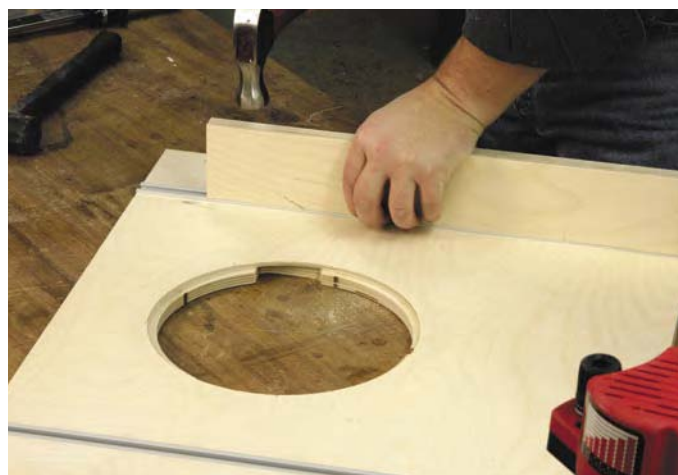

After cutting the grooves for the T-track, tap it in place using a backing block. If you have to tap too hard with the hammer, your groove is too small. Attach the track with 1/2" x #4 flathead screws. Pre-drill and countersink each hole.

the center of each piece along one edge as shown on page 74. This space will be the opening for the router bits.

The sub-face is then glued and nailed to the base. Then glue the braces into the corner formed by the sub-face and base. Make sure to locate the braces as shown to avoid interference with any of the fence handles. I again used brad nails to hold the braces in place.

For the router table to be as useful as possible it needs dust collection. This is achieved by building a simple hood to surround the bit opening in the fence. Drill a hole in the hood back piece. Adjust the hole size to fit your dust collection hose, usually 1 1/4" in diameter.

Then attach the hood sides to the hood back, holding the sides flush to the top edge of the back. Then add the top to the box.

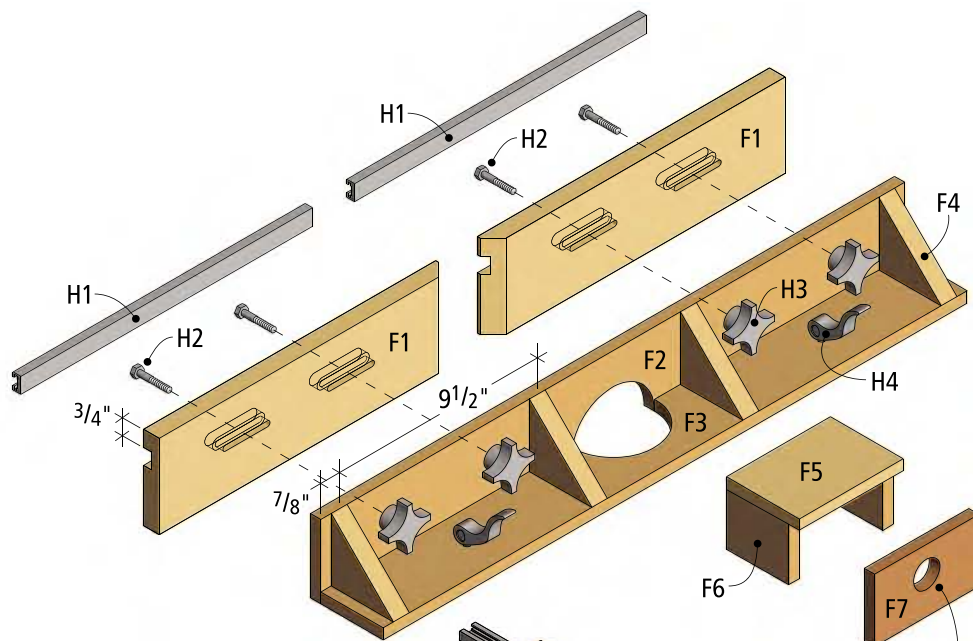

Fence - exploded view

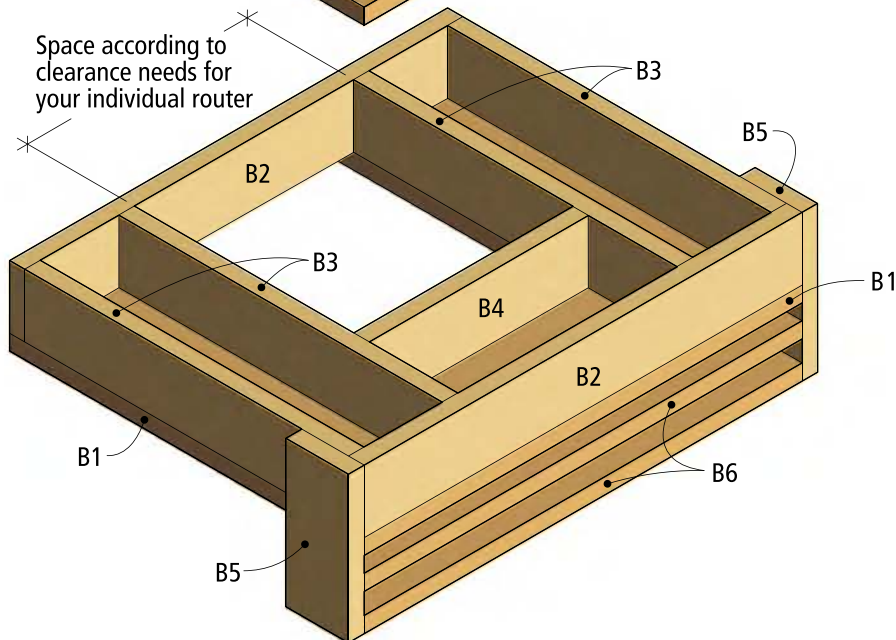
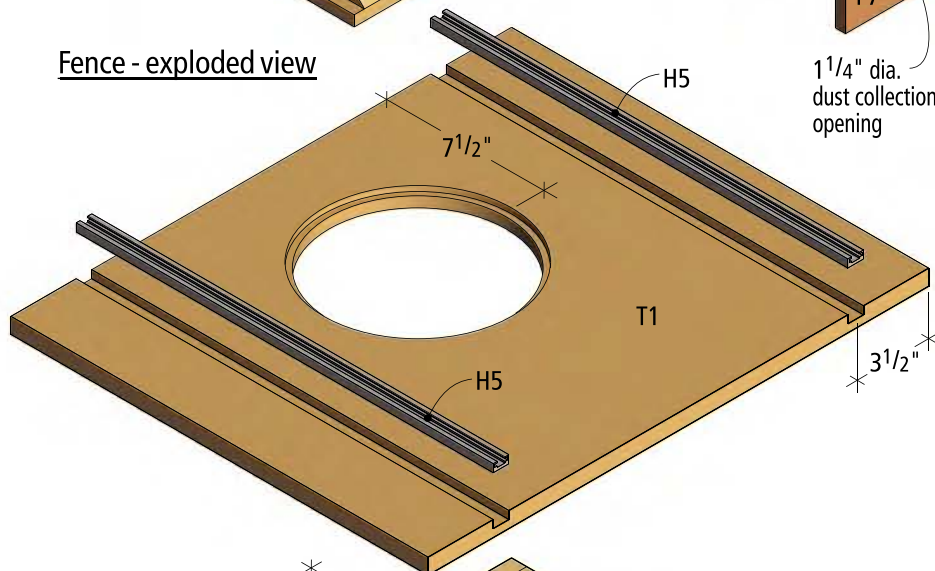

Router table - top removed

SUPPLIES

Lee Valley Tools
800-871-8158 or
leevalley.com

- 4 • Four-arm knobs
#00M55.30, \$1.50 each
- 1 • Veritas Router Base Plate
#05J25.01, \$29.50
- 2 • 2' T-slot extrusions
#12K79.01, \$6.50 each
- 1 • 3' T-slot extrusion
#12K79.03, \$9.50 each
- 2 • Cam clamp mechanisms
#05J51.01, \$3.50 each

The Wood & Shop Inc.
314-731-2761 or
woodshop.com

- 2 • 3/4" x 30" x 30" Birch ply
#BBP3/4C30X30, \$18 each
- 1 • 1/2" x 20" x 30" Birch ply
#BBP1/2 20X30, \$6.90 each

Available from any hardware store:

- 4 • 1 1/2" 1/4" -20 hex-head bolts
- 2 • 1 1/4" 1/4" -20 hex-head bolts

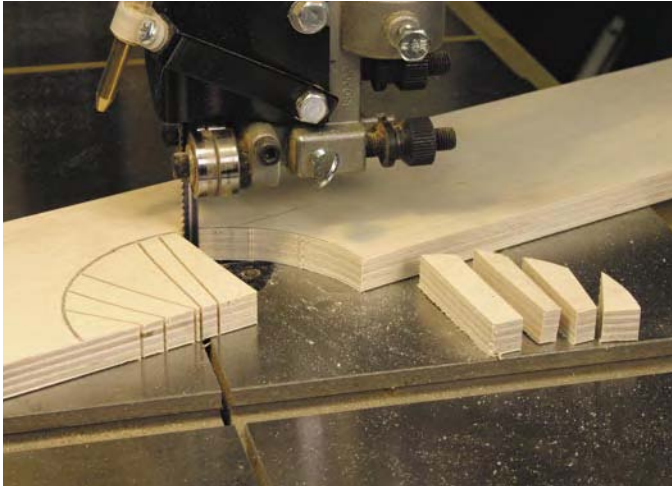

Cutting out the bit clearance hole on the band saw is made simple by first cutting “spokes” toward your line. These relief cuts allow the pieces to fall out in small chunks, rather than fighting with one bigger piece.



With the sub-face and base assembled, add the four triangular braces with glue and brads. Space them adequately to support the fence, but make sure you leave room for the knobs.

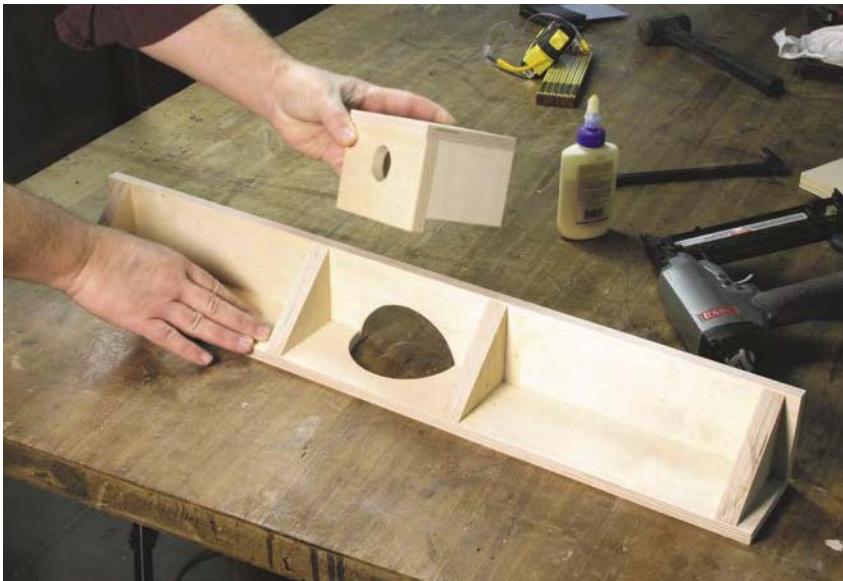

The dust collection hood completes the router table fence. It should seal tightly around the fence to provide the best dust collection, so don't skimp on the glue here.

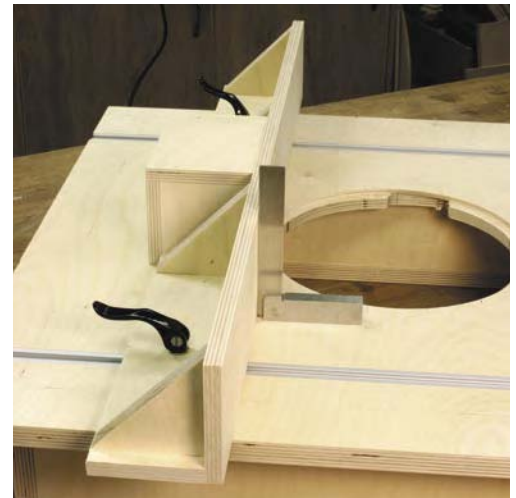

After installing the cam clamps, lock the fence in place on the top and check for square. If adjustment is necessary, you can do it by sanding the base or adding thin shims. You don't want to add shims behind the fence faces because they're moving parts. Adjust the base.

The next step is to locate and drill the holes for the cam clamps that hold the fence to the table and for the knobs that hold the faces. Place the fence assembly over the table and orient the cam clamp holes so they fall in the center of the T-tracks in the top. There can be a little bit of play, but not too much.

Secure the fence to the table with the cam clamps so it seats tightly. Use an engineer's square

to check the fence against the top. If it's not square you need to adjust the base slightly, either by shimming or removing material from the underside of the fence base to make it square.

Next, drill the holes for the fence knobs, again avoiding the braces so the knobs can be easily turned. The holes should be 2" up from the tabletop.

The fence faces are next. To allow the best fence clearance

near the bit, I beveled the inside lip of each of the faces at 45°. Next you need to rout two, 2½"-wide stepped slots in the front of each fence face. These will allow the faces to be moved left-to-right to accommodate different bit sizes.

The easiest way to do this is on a router table, but if you're building your first, you can use a drill press with two different bits. Use a ½"-diameter Forstner bit to first cut a ¼"-deep slot. Then change to a

5/16"-diameter bit to drill through to the back of the fence face. This will create a slot that will let a ½"-hex-head bolt drop into the slot, recessing the head, but capturing the sides of the bolt head to keep it from spinning.

I also added a T-slot fixture to the front of each face. This allows you to attach featherboards, a guard to protect your fingers and other guides. Again, you can use a router or your dado set in the table



Seen from the front, the fence faces have been grooved for the T-tracks, and the clearance holes to attach and adjust the faces are drilled. Note that the face slot shows the rough edges from the overlapping holes made on the drill press. A few minutes with a file and some sandpaper will clean up the slots so the bolt will move smoothly.



After drilling clearance holes, you can locate the holes in the fence faces and add the knobs.



Here you can see the fences in place and the fence attached and ready to run. The T-tracks in the fence faces can be used for featherboards and you can use them to attach a simple guard to keep your hands a safe distance from the bit.



The support brace (customized for my bench vise) holds the router top firmly in place with plenty of clearance (and no wasted space).

saw to make the slot (about 1" down from the top of the fence).

Attach the fence faces using the bolts, washers and knobs.

The Mounting Support

To make the whole thing work, you need to be able to secure the table in your bench vise, but still have access to the router motor. We used a U-shaped support screwed to the sides of the table. The actual size of the support will

depend on your bench vise, but you want the tabletop to rest on the vise as much as possible. In fact, if you can also get the top to rest on the vise at the rear of the table, that's even better support. Our larger router forced us to move the support all the way to the rear of the table. This is something else that can be individualized on your table.

You'll see in the photo that we used two support braces to catch

the vise at both the top and bottom of the jaws for more support. Your vise may require a different arrangement, so give it a test run to make sure it's held tight.

Finishing Touches

With the support mounted you can put your table to work. But you may want to add a step—finishing. While a bare plywood surface will perform reasonably well, a slicker surface will make things move eas-

ier. You can add a topcoat of spray-on lacquer (as we did), or simply add a coat of oil or shellac.

Some other simple additions for your table can include some shop-made featherboards (that will fit nicely in the T-tracks on the fence face) and if you're really industrious, you could actually add a couple of storage drawers to either side of the opening in the top. Customize the project to meet your needs. **PW**

Get More Great Woodworking Resources!

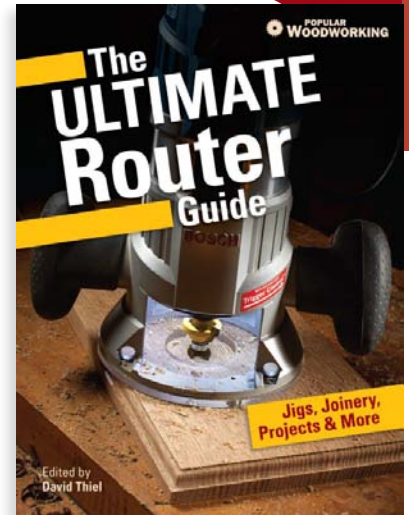
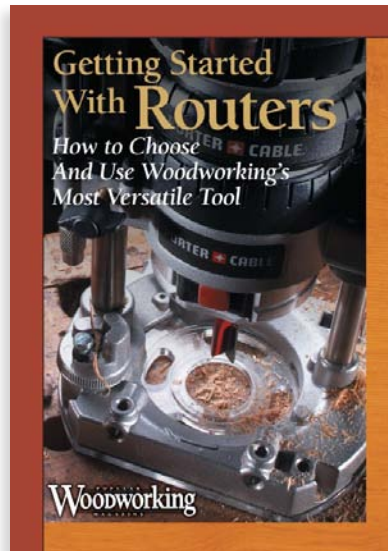
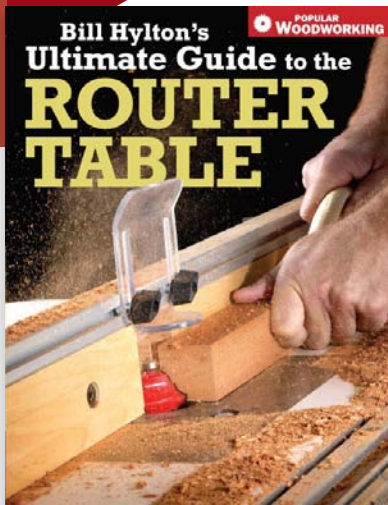

Your free download is an excerpt from the **June 2001**, **February 2004** and **April 2005** issues of *Popular Woodworking Magazine*. You'll find a lot more projects, tips and techniques at ShopWoodworking.com.

**Visit our online store today,
and continue building
your knowledge!**