

I-Beam Drill Press Table

By: Erich Lage

A handy jig for your drill press that let's you drill safely and keep the area clean



I do a lot of metalworking in my shop. This often leaves my drill press table oily and covered in metal shavings. To use my drill press for woodworking, I wanted a quick-change option that would give me a clean work surface without going to the trouble of building a large auxiliary table.

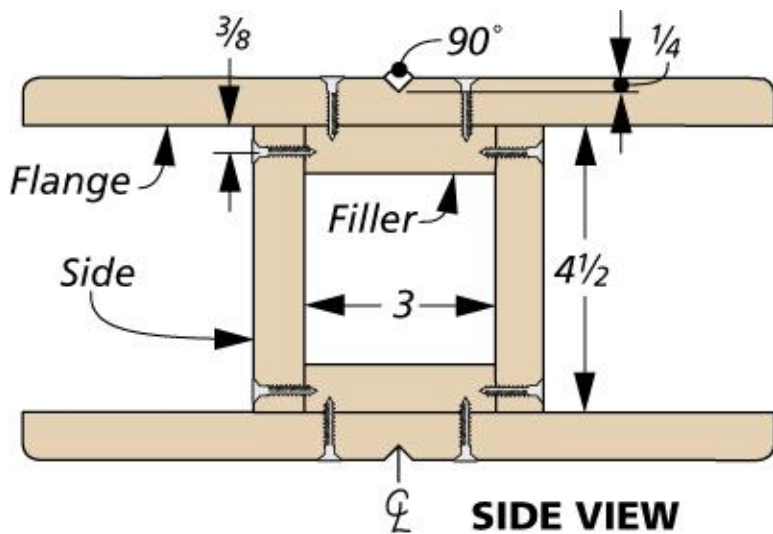
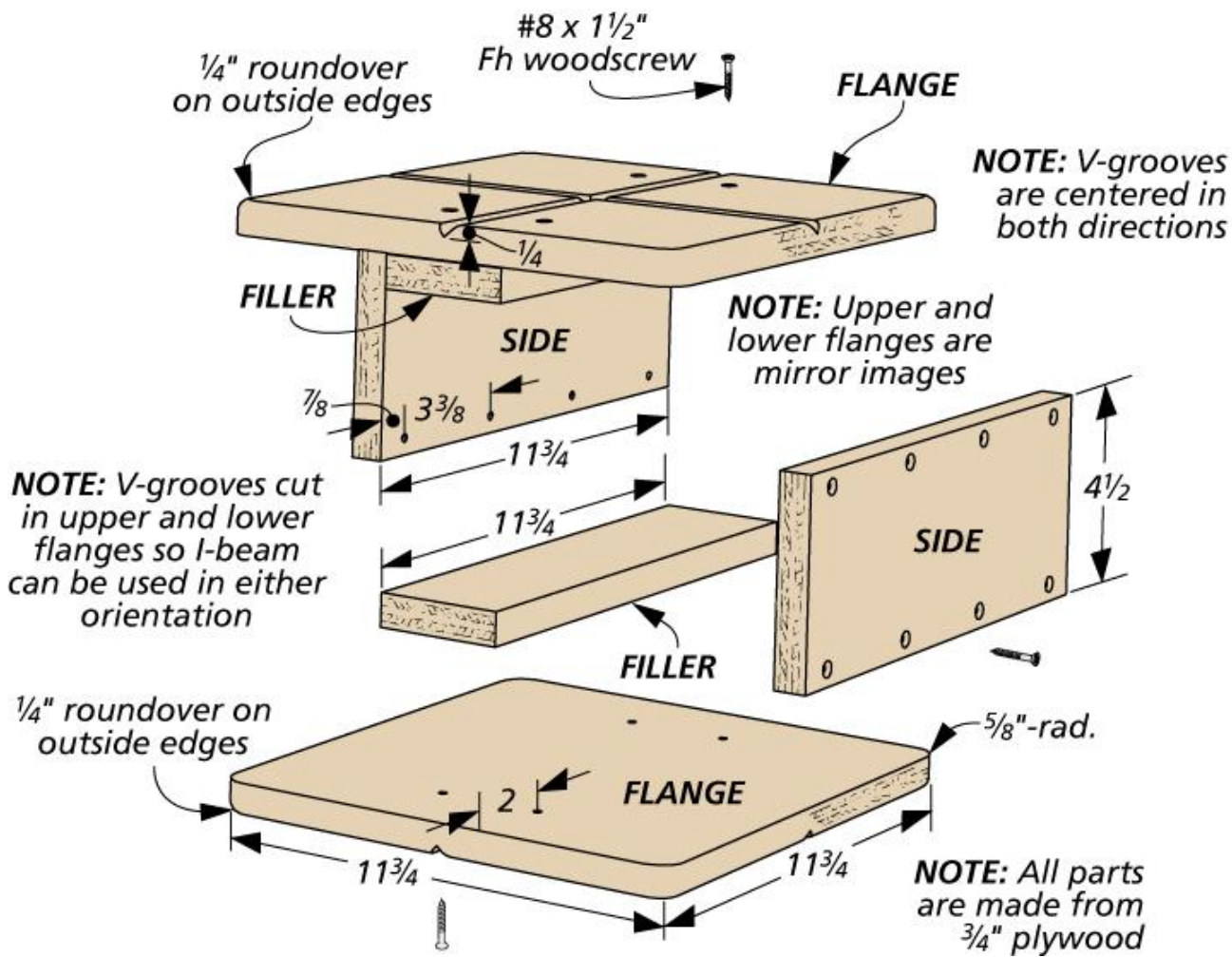

What I came up with is this I-beam accessory that clamps to the drill press table. With this assembly fastened to the table, I can clamp workpieces to the upper flange of the I-beam. The I-beam is made entirely of plywood and is glued and screwed together. Its "I" shape provides support for the workpiece on the upper flange. The lower flange allows the assembly to be clamped to the drill press table. For extra control, I routed V grooves in the upper and lower flanges to help hold round stock.