



*Owner's
Manual*

NO. LD-157

wagner

TRACTOR EQUIPMENT

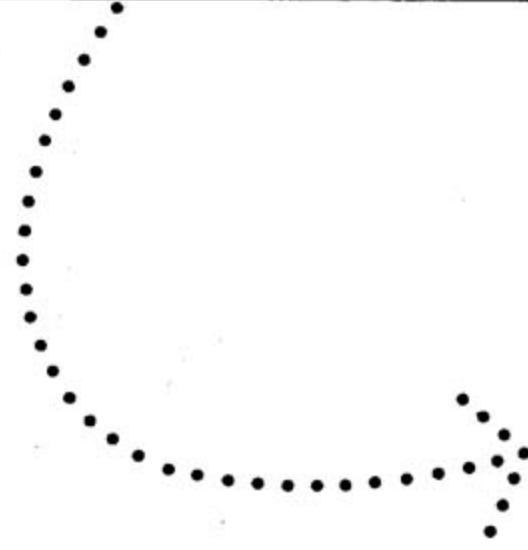

WAGNER MODELS 100, 110, 130,
150 AND 200 POWER-LOADERS

FOR

FORD 2N, 8N, 9N, NAA, 600
AND 800 SERIES TRACTORS

WAGNER IRON WORKS

1905 SOUTH FIRST STREET
MILWAUKEE 7, WISCONSIN

Warranty

The Wagner Iron Works warrants each new Product to be free from defects in material and workmanship for a period of six (6) months from date of delivery to the retail purchaser. To validate warranty, the WAGNER WARRANTY CARD accompanying the Product must be completed in full and returned to the Wagner Iron Works on date of delivery to the retail purchaser. Failure to forward the warranty card on date of purchase shall be conclusive evidence of fulfillment of the Warranty and that the machine is satisfactory to the dealer and retail purchaser, and Wagner Iron Works shall be released from all liability under the warranty.

The Warranty is further good only when Wagner Special Hydraulic Oil or an approved equal has been used and the Manufacturer reserves the right to disallow any and all claims arising from the use of improper hydraulic oil.

The obligation under the WARRANTY, statutory or otherwise, is limited to the replacement or repair at the Manufacturer's factory, or at a point designated by the Manufacturer, of such part or parts as shall appear to the Manufacturer, upon inspection at such point, to have been defective in material or workmanship. This Warranty does not obligate the Manufacturer to bear the cost of labor or transportation charges in connection with the replacement or repair of defective parts, nor shall it apply to Products upon which repairs or alterations have been made unless authorized by the Manufacturer.

wagner
IRON WORKS

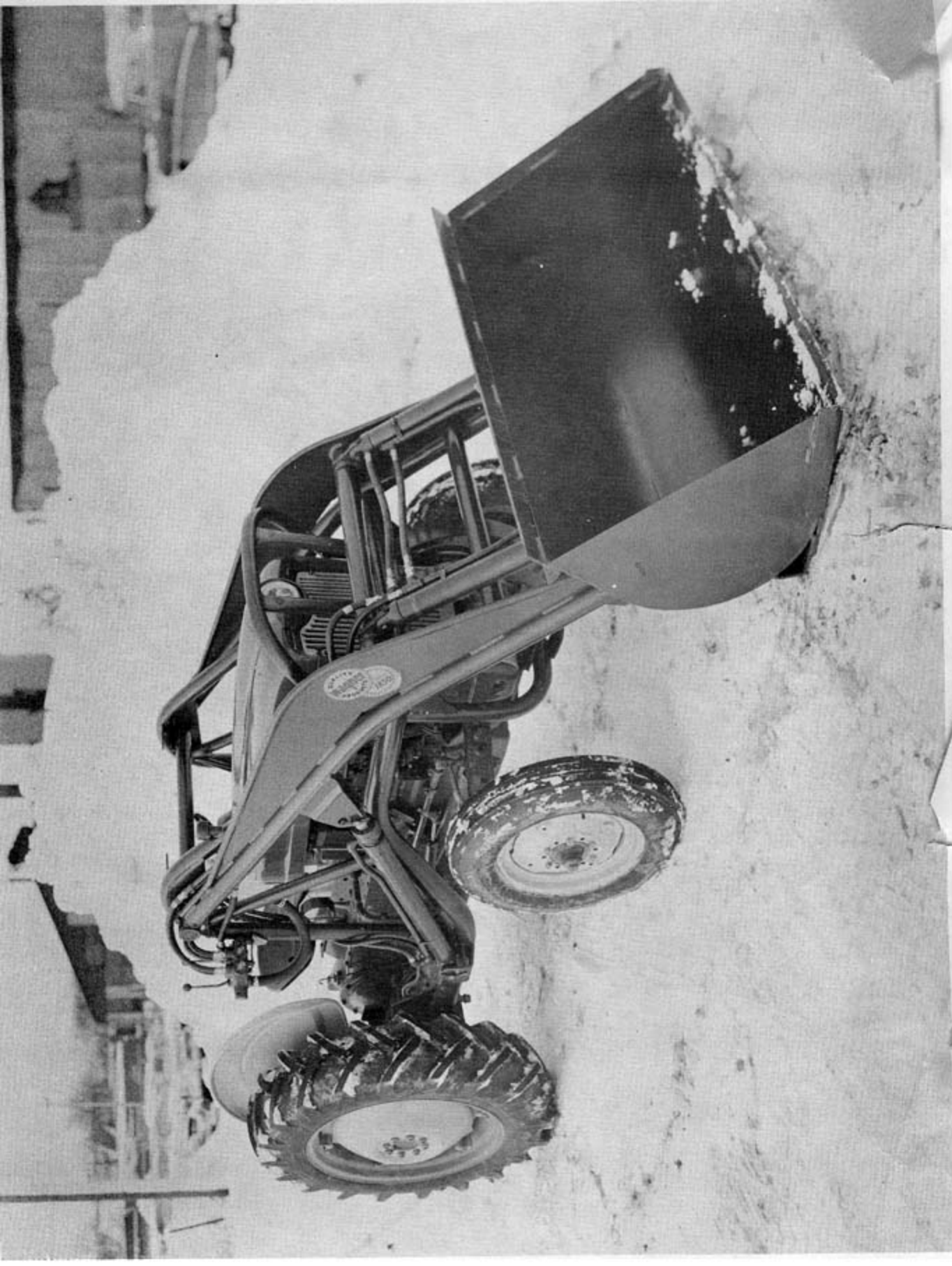

110 Pow'r-Load' for Ford

6



INTRODUCTION

Your Wagner Loader is designed for excellent efficiency, durability, and with the most improved safety features. Precision built, it is the product of Wagner Iron Works, Milwaukee, Wisconsin, manufacturer of the finest hydraulic equipment and fabricated with the technical skill and the most modern manufacturing facilities available.

We feel it is the right of our customers to demand the best, and it is our responsibility to produce the best.

With proper care, your Wagner Loader will give you many efficient, dependable, and labor saving services.

Remember....your Loader deserves the best of care, and only you can provide it. A good daily program of preventive maintenance is your best insurance for continued trouble-free operation.

Power Steering is an important asset to a tractor and front end loader combination. This tractor accessory should always be carefully considered.

The loader is operated by a 14 G.P.M. front P.T.O. driven pump. The 14 G.P.M. pump is supplied as standard equipment. A 17 G.P.M. front P.T.O. driven pump is available, optional, and is recommended when mounting a Wagner Pow'r-Ho in combination.

The Wagner Model 65 Pow'r-Ho cannot be mounted in combination with the Wagner Model 110 series Loader.

The following text covers the setting-up and operating procedure for the Model 100, 110, 130, 150 and 200 Loaders on the Ford Model 2N, 8N, 9N, NAA, 600 and 800 Series Tractors. When the procedure is altered if mounting the Wagner Pow'r-Ho in combination, specific reference is made to the instructions covering the Pow'r-Ho installation.

Throughout this text, the terms right or left and front or rear are standard tractor references as you would sit while driving the tractor.

It is the policy of the Wagner Iron Works to improve its products whenever it is possible and practical to do so. We reserve the right to make changes or add improvements at any time without incurring any obligation to make such changes on products sold previously. To validate the warranty on this equipment, the Warranty Cards enclosed in the Instruction Envelope must be filled out and mailed as directed.

OPERATING & MAINTENANCE INSTRUCTIONS

BEFORE OPERATING - DAILY PROCEDURE

Before operating the loader, check the level of the hydraulic fluid. Remove the breather cap from the main frame reservoir filler pipe. Check with a flexible tape rule and maintain the oil level $\frac{1}{4}$ " from the base of the filler pipe.

Lubricate the loader at the six (6) fittings. The fittings are located at each end of the lift cylinders and on the main frame trunnion. Apply oil to the control valve handle linkage and pin.

Start the tractor engine, set the throttle at $\frac{1}{3}$ open and permit it to circulate the hydraulic fluid and warm up for a few minutes before operating. While the engine is warming up, check for hydraulic fluid leaks and for loose mounting bolts or pins.

OPERATING THE LOADER

When operating a loader that is mounted in combination with a backhoe, be sure that the backhoe boom, dipperstick and bucket are pulled up as near to the tractor as possible. Also, the selector valve knob must be pushed to the forward position.

The control valve is operated as follows:

- a. The outside (right hand) lever operates the attachment cylinders. Pull the lever back to close the cylinders. Push the lever forward to extend the cylinders.
- b. The inside (left hand) lever operates the lift cylinders. Pull the lever back to raise the dipperstick. Push the lever forward to lower the dipperstick.

Do not lower the dipperstick or dump attachment unless the tractor is running since in doing so the pump cannot supply oil required for displacement in the double acting cylinders. As a result, the oil level in the reservoir will rise excessively and may overflow at the breather cap.

The loader control valve by-pass pressure is factory set between 1850 and 1950 pounds per square inch pressure. The relief assembly in the valve cannot be adjusted under any circumstances unless a pressure gauge is installed in the system. The loader warranty will be automatically voided if the relief assembly is adjusted to operate in excess of the recommended operating pressure. Always consult your Wagner Implement Dealer before attempting to regulate the operating pressure.

IMPORTANT RULES FOR SAFE OPERATION

When lowering the loader always lower smoothly. Do not open the valve full and then snap it closed.

Over inflation of front tractor tires to increase loader capacity will be found to be very uneconomical.

The lower the load is carried, the greater the safety factor.

When carrying a load, watch for ridges or depressions. Drive slowly over rough or uneven ground.

Do not make sharp turns when backing up with the bucket filled and raised.

Avoid operating sideways on steep slopes whenever possible.

Never leave a loader in a raised position or work under a raised loader unless it is securely blocked.

PREVENTIVE MAINTENANCE

1. Lubricate at all grease fittings daily. There are six (6) fittings in all, located at each end of the lift cylinders and on the main frame trunnion.
2. Check the tightness of all mounting bolts after first eight hours of operation and weekly thereafter. Loose bolts can cause unsatisfactory operation and excessive wear.
3. Check all pivot pins daily for loss of cotter pins or retainer springs.
4. The oil level in reservoir must be checked daily. A low oil level can cause hesitant or jerky operation of the dipperstick or attachment and may result in serious damage to the hydraulic system.
5. Oil must be drained and reservoir flushed after the first fifty hours of operation. Filter the oil and return to the reservoir adding if necessary to the proper level - $\frac{1}{4}$ " from base of filler pipe. Drain plug is located under the rear right side of main frame.
6. When starting a new unit the hydraulic fluid filter should be checked after ever five hours of operation for the first forty hours. If at that time the filter is clean when checked, the inspection period can be extended to every forty hours of operation. The reason for such careful attention to this filter is that more than a railway tank car load of fluid passes through it during a ten hour period of operation.

A clogged filter will be indicated by one or more of the following:

Overheating, loss of power, slow and erratic operation or noisy pump.

7. Change the oil and flush the reservoir every 600 hours of operation. Use clean funnels and containers when handling oil.
8. Efficient operation of any hydraulic system depends to a large extent on CLEAN OIL. Always be careful when servicing the hydraulic system to prevent dirt or foreign material from entering the hydraulic system.
9. Check the tightness of the set screws in flexible coupling flanges periodically. Should the set screws have a tendency to work loose, they can be cinched by peening the threads in the flanges with a center punch.
10. Straighten any hoses that are kinked or chafing. The hoses used are of steel wire braid covered with rubber. It is not necessary to replace them just because the metal braid is showing. Any indication of either hydraulic fluid or air leak should be corrected immediately.
11. Extend each cylinder rod and examine for scratches. If a scratch occurs, examine the wiper and replace it if imbedded abrasive is present. Polish the scratch off the rod with a piece of fine emery cloth. Use the emery cloth with rotary motion. IMPORTANT: Do not polish lengthwise on the rod. When the scratch is removed, dip the emery cloth in clean oil and polish the rod to a high finish.
12. There should always be a light film of oil around the packing nut and on the extended cylinder rod. When the cylinder is retracted the wiper ring takes off any dirt along with most of the oil film.

The packing nut should be only a little more than hand tight and should always be tightened with a spanner wrench. Never use a hammer and punch or pipe wrench. Excessive leaking at the packing nut indicates the need for replacing the packing. The wiper should always be examined very carefully for wear or abrasive imbedded in the wiper and replaced if there is any doubt about its condition.

TROUBLE SHOOTING AND SERVICE

| TROUBLE | PROBABLE CAUSE | REMEDY |
|-----------------------------------|-------------------------------------|-----------------------------------------------------------------------------------------------------------|
| 1. Loader will not lift capacity. | 1. Insufficient pressure. | 1. Check valve and pump pressures with Pressure Gage Kit and adjust if necessary. |
| | 2. Oil leakage. | 2. Tighten all hose connections and adjust cylinder gland nuts. |
| | 3. Low R.P.M. | 3. Increase R.P.M. |
| | 4. Faulty pump. Gear journals worn. | 4. Replace with new pump or replace pump body, gears and wear plates. |
| | 5. Oil foaming. | *5. Use Wagner Special Hydraulic Oil. Do not operate at full throttle continually. Change oil seasonally. |
| | 6. Low oil level. | 6. Fill to correct capacity. |
| | 7. Obstruction in valve. | 7. Remove and clean out valve. |
| | 8. Plugged strainer. | 8. Remove strainer screen and clean. Filter oil before returning to reservoir. |
| | 9. Worn drive assembly. | 9. Replace worn parts and check alignment. |
| | 10. Pump suction air leak. | 10. Tighten pump intake connections. Use pipe joint compound. |
| 2. Load drops or settles. | 1. Scored pump. | 1. Replace with new pump or replace worn parts. |
| | 2. Scored piston rod. | 2. Replace piston rod and packings. |
| | 3. Improper hydraulic oil. | 3. Use only Wagner Special Hydraulic Oil. |
| | 4. Worn valve. | 4. Replace with new valve or replace worn parts. |
| | 5. Air bound. | 5. Bleed cylinders to expel air. See Operating Instructions for procedure. |
| 3. Loader chatters when raising. | 1. Clogged breather. | 1. Flush out system. Replace breather. |
| | 2. Clogged strainer. | 2. Clean strainer and filter oil. |
| | 3. Tight gland nuts. | 3. Back off gland nuts 1/4 turn and tighten "hand" tight. |
| | 4. Insufficient oil level. | 4. Fill to correct capacity. Refer to Operating Instructions. |

| TROUBLE | PROBABLE CAUSE | REMEDY |
|----------------------------------------------|---------------------------------------------|------------------------------------------------------------------------------------------------------------------------------------------|
| 4. Leaky cylinders. | 1. Loose gland nuts. | 1. Tighten gland nuts "hand" tight. |
| | 2. Damaged packing or seals. | 2. Replace packing and seals. |
| | 3. Scored piston rods. | 3. Replace piston rod, packing, O ring and seals. |
| 5. Leaky valve. | 1. Damaged or worn seals. | 1. Replace seals. |
| | 2. Scored plunger. | 2. Replace with new valve or replace plunger. |
| | 3. Threads in ports stripped. | 3. Replace with new valve or replace valve body. |
| 6. Sticky valve plunger. | 1. Paint on plunger. | 1. Clean the plunger. |
| | 2. Not broken in. | 2. Operate several times. |
| 7. Leaky pump. | 1. Loose seals and hose connections. | 1. Replace pump seals and tighten hose connections. Use pipe joint compound. |
| | 2. Damaged gaskets. | 2. Replace gaskets. |
| 8. Blowing pump seals. | 1. Clogged hydraulic lines. | 1. Flush system. |
| | 2. Valve not by-passing. | 2. Adjust pressure setting on valve. |
| | 3. Excessive pressure. | 3. Adjust pressure settings on valve. |
| | 4. Drive shaft not aligned. | 4. Realign drive assembly. |
| 9. Coupling failure. | 1. Poor drive assembly alignment. | 1. Replace worn or damaged parts and realign drive assembly. |
| * 10. Air bound cylinder. | 1. Air pocket formed when filling with oil. | 1. Bleed cylinders to expel air. Refer to Operating Instructions. |
| 11. Attachment cylinder piston rod failures. | 1. Piston rod end loose. | 1. Tighten set screw on piston rod end. |
| | 2. Scored piston rod. | 2. Replace piston rod, packings or leather cups. Flush out system. Inspect gland and cylinder bore for score marks before re-assembling. |
| | 3. Worn leather cups or packings. | 3. Replace packings or cups and flush out system. Inspect gland and cylinder bore before re-assembling. |
| | 4. Improper use of attachment. | 4. Use attachments properly. |

* Applies to single acting cylinders only. Double acting cylinders will bleed themselves in operation.

| TROUBLE | PROBABLE CAUSE | REMEDY |
|-----------------------------------------------------------------------------|---------------------------------------------------------------------------------------------------------------|----------------------------------------------------------------------------------------------------------------------------------------------------------------------------------------------------------------------|
| 12. Excessive wear on mounting pins. | 1. Insufficient grease on implement pins. | 1. Grease fittings. |
| | 2. Grooved mounting pins. | 2. Ream out holes in mounting lugs. |
| 13. Loader does not fit. | 1. Damaged after leaving factory (damaged in shipment to destination or abuse when unloading at destination.) | 1. File proper claims and report on A.F.A. form. |
| 14. Broken welds and leakage in the frame. | 1. Loose mounting bolts. | 1. Tighten all mounting bolts securely. |
| | 2. Overloading. | 2. Use equipment according to specifications. |
| 15. Bending attachment cylinder piston rods or damaging self-leveling Assy. | 1. Improper attachments or abuse. | 1. Use only Wagner fabricated attachments and use in accordance with specifications. The attachment cylinders and / or self-leveling assembly cannot be warranted by the factory unless Wagner attachments are used. |
| 16. Oil flows from reservoir breather when lowering dipperstick. | 1. Air in single acting side cylinders. | 1. Bleed cylinders. For proper procedure, see Operating Instructions. |
| | 2. Down pressure side cylinders closed when tractor was not running. | 2. If loader has down pressure side cylinders, do not lower dipperstick unless tractor is running. |

SPECIAL WAGNER HYDRAULIC FLUID

Wagner hydraulic mechanisms require a special type of hydraulic fluid. Some hydraulic systems on the market can use water, glycerine and water mixtures because mineral oils would cause deterioration of packings used in the mechanisms. Other hydraulic mechanisms can use organic fluids like mineral oils as they may not have packings present or use a packing material which is impervious to mineral oils. Some hydraulic mechanisms are designed to operate with heavier oils. In all cases it should be remembered that the lifting power and general operation of the hydraulic mechanism is carefully calculated and adjusted to balance the maximum load which the designer determined the mechanism would handle and withstand. For this reason the selection and application of the proper hydraulic fluid is most imperative. Since the proper operation of the unit depends upon a definite quantity of oil passing through small orifices in a given time, the oil must maintain relatively the same viscosity at all temperatures. Petroleum oils as a group have a wide range of

temperature variations. The hydraulic oil for our equipment must be capable to resist the formation of excessive foam and the formation of emulsion which can form from moisture condensation in the system. Also, our hydraulic oil must have sufficient oiliness, plus a low coefficient of friction, and it must have the proper fluidity and pour point and volatility range, plus being anti-corrosive and anti-gum forming in nature. Also it must have the right compressibility factor and properly lubricate the internal working parts of the hydraulic mechanism.

For these reasons it is imperative that Wagner Hydraulic Fluid is used in the initial filling and replenishing of the fluid in Wagner equipment.

The correct properties in the Wagner Hydraulic Fluid were arrived at through precise and lengthy calculations and laboratory field tests. Many of our customers have experienced costly repairs and delays due to the use of improper types of hydraulic fluid.

NOTE: The following oils have been thoroughly tested and are the only fluids that have full Wagner approval - Texaco (AZ-R-O), Cities Service (Peacemaker 150T), Stanol (#15) and I.H. Touch Control Fluid.

SETTING-UP INSTRUCTIONS

GENERAL

The purpose of this section is to provide the serviceman with a procedure sequence which will accomplish the loader mounting operation quickly and safely. Only ordinary hand tools and standard shop hoisting equipment are needed.

To simplify locating loose parts while setting-up the equipment, the contents of each box should be sorted out on separate cloths or sheets of heavy paper.

Lubricate all bearings and moving parts as you proceed and see that they work freely. Place pins into corresponding holes and check for proper fit before mounting.

The lubrication fittings used with the equipment have self-tapping threads.

Before delivery to the owner, the equipment must be checked out in accordance with the Dealer Pre-delivery Service Recommendations at the end of this section. Also review the operation and maintenance instructions with the owner and be certain that they are understood.

PREPARING THE TRACTOR

MODEL NAA, 600 AND 800 SERIES TRACTOR

1. Remove the front grill and cut out at bottom as shown in Figure 1.
2. Remove crankshaft ratchet nut and plain washer from engine crankshaft. Secure the tractor pulley hub to the crankshaft with a special cap screw, internal lockwasher and a special washer supplied with the loader.
3. Remove the four cap screws from the tractor pulley. Bolt the adapter assembly evenly and securely to the tractor pulley using four 7/16" - 14 x 1-1/2" cap screws and lockwashers provided.

NOTE

The four steel bushings protrude approximately 1/8" through the back side of the adapter assembly. This provides additional flexibility in the drive assembly. The adapter must be installed with the four steel bushings resting evenly against the tractor pulley.

4. Assemble the flexible coupling to the drive shaft using a #9 Woodruff Key. Tighten the set screw with an allen wrench.
5. Insert the drive shaft through the crank opening and connect to adapter. The drive shaft has a left hand thread.
6. Remove the cap screw in the front axle pin.
7. Place a 1/2"-20 N.F. x 1-3/4" cap screw with a 1/2" lockwasher and a plain washer through the top center hole of the front mounting bracket. Place two 3/16" thick special washers over the cap screw on the inside of the mounting bracket. (See Figure 1)

NOTE

When mounting on a 600 or 800 series tractor either install one additional tractor axle pin "locking flange" and one 1/2" x 3/16" thick special washer, or use two special washers(28), supplied in loader mounting box, between front hanger bracket and single locking flange as indicated in paragraph 7 above.

8. Place a 5/8"-18 N.F. x 1-1/2" cap screw with a 5/8" lockwasher through the center hole of the front mounting bracket. Place a 1/4" thick special washer over the cap screw on inside of mounting bracket. (See Figure 1).
9. Connect a 3/4" hex nut to the tie bar bracket. Place the tie bar bracket (38) into the tractor front motor support and mount loosely using a 3/4" lockwasher and hex nut.

NOTE

The tie bar bracket provides additional support for the front crossmember on all Ford Tractors. The tie bar brackets are optional equipment on the Model 110 Loader.

10. Insert a 5/8"-11 x 1-1/2" cap screw from the inside through the bottom center hole in the front mounting bracket. Place the mounting bracket against the tractor front axle support and tighten the 1/2" N.F. and the 5/8" N.F. cap screws. The 1/2" N.F. cap screw in the top center hole connects to the tractor front axle pin.
11. Connect the tie bar bracket to the remaining two holes at the bottom of the front mounting bracket with two 5/8"-18 x 2-1/4" cap screws, lockwashers and hex nuts.

12. Using the two remaining top holes in the front mounting bracket as a guide, drill two $17/32$ " holes through the front axle support. Insert a $1/2$ "-20 N.F. x $1-1/4$ " cap screw through each of these holes and secure with $1/2$ " lockwashers and $1/2$ " N.F. hex nuts.

MODEL 2N, 8N AND 9N

1. Remove the front grill and cut out at bottom. Secure the loose vertical grill work with inside (52) and outside (53) grill straps. (See Figure 1).
2. Set tractor brakes and jack up front end of tractor under crankshaft to relieve the weight on front wheels.
3. Remove the following in this order:
 - a) Radius rods from the front axle.
 - b) Cap screw in front axle pin.
 - c) Cap screw securing front axle support to tractor in order to raise radiator.
 - d) Cap screws securing crankcase to front axle support and remove axle support.
 - e) Axle pin from axle support.
 - f) Fan belt from pulley.
 - g) Crankshaft ratchet from end of crankshaft and remove pulley.
4. Secure Wagner Sheave (10) to the tractor crankshaft with a special screw (3), internal lockwasher (2) and a special washer (54) supplied with the loader. Press the hub and pin assembly (11) firmly into the rubber bushings (10A) of the sheave. The hub must be flush with the face of the sheave. (See figure 1).
5. Enlarge the $7/8$ " diameter hole in the tractor front axle pin to 1". Anneal if necessary.
6. Place fan belt on sheave and re-assemble the front end of the tractor except for the grill. Remove the jack or blocks from under the crankcase.
7. Assemble the flexible coupling (13) to the drive shaft (12) using a "9 Woodruff Key. (See Figure 1). Tighten set screw with Allen wrench.

8. Insert the drive shaft through crank opening and connect to the hub and pin assembly. The drive shaft has a left hand thread.
9. Place a 1/2"-20 N.F. x 1-3/4" cap screw with a 1/2" lockwasher and plain washer through the top center hole of the front mounting bracket. Place a 3/16" thick special washer over the cap screw on inside of mounting bracket. (See Fig.1)
10. Connect a 3/4" hex nut to the tie bar bracket. Place the tie bar bracket (38) into the tractor front motor support and mount loosely using a 3/4" lockwasher and hex nut.

NOTE

The tie bar bracket provides additional support for the front crossmember on all Ford Tractors. The tie bar brackets are optional equipment on the Model 110 Loader.

11. Insert a 5/8"-11 x 1-1/2" cap screw from inside through the bottom center hole in the front mounting bracket. Position the mounting bracket against the tractor front axle support and turn the 1/2" N.F. cap screw in top center hole snugly into the hole provided in the front axle pin.
12. Connect the tie bar bracket to the remaining two holes at the bottom of the front mounting bracket using two 5/8"-18 x 2-1/4" cap screws, lockwashers and hex nuts.
13. Level off the front mounting bracket and tighten the 1/2" N.F. cap screw in the top center hole. Using the remaining two top holes in the front mounting bracket as a guide, drill two 17/32" holes through the front axle support. Insert a 1/2" x 20-N.F. x 1-1/4" cap screw through each of these holes and secure with 1/2" lockwashers and 1/2" N.F. hex nuts.

PUMP MOUNTING

1. Bolt the pump mounting bracket snugly to the front mounting bracket using four 1/2"-13 x 1-1/2" cap screws, plain washers, lockwashers and nuts.
2. Clamp the pump (Item 14 or 43, Fig.1) carefully in a vise between two wooden blocks.
3. Connect a 1/2" x 3/4" hex bushing and a 1/2" x 16-3/4" hose assembly, in that order, to the suction side of the pump. The hex bushing is not necessary for the 17 G.P.M. pump.

NOTE

Always use pipe sealing compound when assembling pipe fittings to prevent oil leakage.

4. Connect a 3/4" x 1-3/4" T.O.E. nipple and a 1" I.D. x 13" neoprene hose to the pressure side of the pump. Use a 1" I.D. x 15" neoprene hose when mounting the 17 G.P.M. pump.
5. Position the 14 G.P.M. pump (14) on the pump mounting bracket (36) and connect the pump shaft to the coupling flange using a #9 Woodruff Key. Tighten the set screw. (See Figure 1).
6. Bolt the pump to the mounting bracket with two 1/2"-13 x 1-1/4" cap screws, lockwashers and special washers.
7. When mounting the 17 G.P.M. pump an additional bracket is needed. Mount the pump mounting bracket (46) to the pump mounting bracket (36) with two 1/2"-13 x 1-1/4" cap screws, lockwashers and special washers. (See Figure 1).
8. Place the pump on the pump mounting bracket and connect the shaft to the coupling flange using a #9 Woodruff Key. Tighten set screw of coupling assembly. The 17 G.P.M. pump has two bolts in the assembly which are secured to the bracket using 7/16" hex nuts and lockwashers.
9. Check the pump for proper alignment and make adjustments as necessary. When the pump is properly lined up, tighten the mounting bolts on the pump and the pump mounting bracket.

LOADER PRE-ASSEMBLY

NOTE

Always use a quality sealing compound on the threads of steel pipe fittings to prevent oil leakage.

1. Separate the loader main frame and dipperstick bundle.
2. Raise the dipperstick into position on the main frame. Connect to main frame with a pivot rod and two 5/8"-11 x 3-3/4" cap screws, lockwashers and nuts. (See Figures 4, 5 and 6).
3. Install self tapping lubrication fittings at each side of main frame top cross member and at each end of lift cylinders. (See Figures 4, 5 and 6). There are six grease fittings in all.

4. Connect a 1/2" x 90° street elbow to the forward end of each lift cylinder oil line. Connect a 1/2" x 90° elbow to the other end of the oil lines. (See Figure 2). Tighten oil lines into front port of each lift cylinder. Connect a 1/2" x 90° street elbow to the rear port of each cylinder.
5. Connect the base of each lift cylinder to the mounting lugs on the mainframe using a 1" x 5" pin, use a 1" x 6-1/4" pin for Model 200 Loader, and 3/8" x 2-1/2" cotter pin.
6. Connect each lift cylinder piston rod to mounting lugs on the dipperstick using a 1" x 4" pin, use a 1" x 5" pin on Model 200 Loader, and 3/8" x 2-1/2" cotter pin.
7. When mounting Model 100 and 130 Loaders connect a 1/2" x 90° street elbow, 1/2" x 19-1/2" oil line and 1/2" x 90° elbow to the lower port of attachment cylinder. (See Figure 4). Connect the attachment cylinder to the mounting lug on the dipperstick using a 3/4" x 3-3/16" pin and two 3/4" retainer springs.
8. When mounting Model 150 and 200 Loaders connect a 1/2" x 90° street elbow to the forward end of each attachment cylinder oil line. Connect a 1/2" female-female adapter union to the opposite end. (See Figure 5). Tighten oil lines into front port of each attachment cylinder. Secure each attachment cylinder to mounting lugs on dipperstick using a 3/4" x 3-3/16" pin and two 3/4" retainer springs.

NOTE

Paragraphs 9 through 15 are for Wagner Model 110 Loader only.

9. (See Figure 7). Connect a 1/2" x 23-1/2" hose assembly to the port at the clevis end and another to the pipe tee on one of the attachment cylinders.
10. Attach the cylinder to the lug on the left side the dipperstick with a 3/4" x 3-5/16" pin and two 3/4" retaining rings.
11. Secure a 1/2" close nipple, 1/2" pipe tee, and a 1/2" female-male adapter union, in that order, to the port at the clevis end of the other attachment cylinders (See Figure 7). Connect the 1/2" end of a 1/2" x 3/8" x 20-3/4" hose assembly to the center port of the pipe tee.
12. Connect a 1/2" female-male adapter union to the center port of the pipe tee on the cylinder oil line. Connect the 1/2" end of a 1/2" x 3/8" x 20-3/4" hose to the top port of this tee.

13. Attach the cylinder to the lug on the right side of the dipperstick with a $3/4$ " x $3-5/16$ " pin and two $3/4$ " retaining rings.
14. Join the two $1/2$ " x $23-1/2$ " hoses on the left attachment cylinder to the adapter unions on the right cylinder. The hoses must be connected so that the rear port of one cylinder is joined to the rear port of the other and the front port of one cylinder is joined to the front port of the other.
15. Join the hoses (Item 2, Figure 7) in the pipe tees on the right cylinder assembly to the oil lines on the dipperstick. The hoses must be connected to the oil lines so that the rear ports in the attachment cylinders are joined to the front port in the control valve and the front cylinder ports are joined to the rear valve port.
16. When mounting the Model 150 and 200 Loaders remove the $3/8$ " pipe caps from the rear end of the oil lines on the right side of the dipperstick and left end of the equalizer lines and install $3/8$ " female-female adapter unions in place with the solid end of union to pipe. Connect $3/8$ " pipe tees, $3/8$ " x 90° street elbows and $3/8$ " female-male adapter unions to front end of oil lines as shown in Figure 2.
17. When mounting Wagner Model 130 and 110 DA Loaders, remove $3/8$ " pipe caps from each end of the oil lines on the right side of dipperstick and left end of equalizer lines and install $3/8$ " female-female adapter unions in place with solid end of union to pipe.
18. If mounting the Model 100 and 110SA Loaders, remove $3/8$ " caps from each end of the oil lines on right side of dipperstick and left end of equalizer line and install $3/8$ " female-female adapter unions in place with solid end of union to pipe.
19. When mounting the Model 150 and 200 Loaders connect four $3/8$ " x $1/2$ " x $18-3/4$ " hoses between oil lines and attachment cylinders. (See Figures 2 and 5). Secure oil lines with three #12S line clamps.
20. For Model 130 and 110 DA connect the $1/2$ " end of two $1/2$ " x $3/8$ " x $16-3/4$ " hoses to attachment cylinder and join to the oil lines on right side of dipperstick. Using line clamp #12S secure the oil line to the attachment cylinder.

21. Remove the 1/2" caps from each end of the pressure feed line on right side of main frame and install a 1/2" female-female adapter unions in place with solid end of union to pipe.
22. When mounting Models 100 and 110 SA Loaders remove plugs from center and lower port of pipe tee on right side of equalizer line. Connect a 3/8" female-male adapter union to lower port and a 1/2" x 90° street elbow and 1/2" female-male adapter union to center port. (See Figure 3).
23. For Model 110 DA and 130 Loaders, remove plugs from center and lower port of pipe tee on right side of each equalizer line. Connect a 3/8" female-male adapter union to the lower ports and a 1/2" x 90° street elbow and 1/2" female-male adapter union to center ports. (See Figure 2).
24. Remove plug from lower port of tee on right side of each equalizer line on Model 200 Loader. Connect a 3/8" female-male adapter union to lower ports. Connect the flow control valve to one of the pipe tees as shown in Figure 2 and install 1/2" female-male adapter unions.
25. When mounting Model 150 Loader, remove plugs from center and lower port of pipe tee on right side of each equalizer line. Connect a 3/8" female-male adapter union to lower ports and a 1/2" x 90° street elbow to center ports. Connect the flow control valve to one of the pipe tees as shown in Figure 2 and install 1/2" female-male adapter unions.

NOTE

When installing the flow control valve, check to see that the adjusting screw is backed off about three turns from the extreme "in" position and tighten the jam nut. The "arrow" stamped into the valve must point toward the port in the control valve.

26. Install the handles on the control valve. Connect a 1/2" x 90° street elbow to pressure inlet port of control valve and a 3/4" x 1-3/4" T.O.E. nipple to return port. (See figures 2 and 3).
27. Mount control valve on valve mounting bracket attached to right side of main frame using three 5/16"-18 x 3/4" cap screws and lock-washers.

28. When mounting the Model 200 Loader, connect a 1/2" x 18" hose to the street elbow at pressure inlet port of control valve and join to pressure feed line.
29. Connect a 1/2" x 16-3/4" hose to the street elbow at the pressure inlet port of the control valve and join to pressure feed line.
30. Connect a 1/2" x 16-3/4" hose to each lift cylinder port in control valve and join to equalizer lines. (See Figures 2 and 3).

NOTE

The hose connected to the left rear cylinder port in the control valve must be joined to the flow control valve on Model 110 DA, 150 and 200 Loaders.

31. Connect the 1/2" end of a 1/2" x 3/8" x 16-3/4" hose, a 1/2" x 3/8" x 18-3/4" hose is used on Model 200 Loader, to each right cylinder port in the control valve and join to oil lines on right side of dipperstick. (See Figures 2 and 3).
32. Connect the 1/2" end of a 1/2" x 3/8" x 22-3/4" hose to each street elbow, in lift cylinders and join to equalizer lines.

NOTE

The hoses connected to the rear ports in the cylinders must be joined to the equalizer lines.

33. Using two 1" x 5W hose clamps, secure one end of 1" I.D. x 18" neoprene hose to nipple at return port of control valve and connect other end to nipple on main frame right side diagonal brace.
34. Connect 3/4" x 45° elbow, 3/4" close nipple, strainer assembly and 3/4" x 1-3/4" T.O.E. nipple to reservoir outlet nipple at right front end of main frame. Secure the T.O.E. nipple to strainer outlet beforehand. (See Figure 1).
35. Using two 1" x 5W hose clamps, secure one end of a 1" I.D. x 13" neoprene hose to nipple at outlet of strainer and connect other end to nipple at inlet side of pump.
36. Connect a 1/2" x 16-3/4" hose to pressure side of pump and join to pressure feed line.

37. Install the attachment to dipperstick using two 1" x 5" pins at hinge points and two 3/4" x 4-1/2" pins on Model 100, 110, 130 and 150 Loaders and 3/4" x 4-5/8" pins on Model 200 Loader to connect cylinder piston rods to the upper lugs on attachment.

MOUNTING THE LOADER ON THE TRACTOR

1. Install the modified tractor grill.
2. Remove the nuts and lockwashers from tractor fender bolts and remove fenders.
3. Install the right and left hand "Quick-Detach" rear mounting brackets on tractor axle together with fenders using the original fender bolts. (See Figures 4, 5 and 6). Do not tighten down until after the loader main frame assembly is installed.

NOTE

1st and 3rd holes from rear of brackets are used with 600 and 800 series tractors. The Model NAA Tractor utilizes the 2nd and 3rd holes from rear. Model 9N, 2N and 8N Tractors use the 3rd and 4th holes from rear of brackets.

4. Using a hoist having a minimum rated capacity of 2000 lbs., raise the main frame and dipperstick to a height sufficient to clear the front axle.
5. Carefully roll tractor into the main frame and position on front and rear mounting brackets.
6. Bolt the rear mounting pads on the main frame loosely to the rear mounting brackets using four 3/4"-10 x 2" cap screws, lockwashers and nuts.
7. Bolt the front mounting pad on the main frame to the front mounting bracket using three 5/8" x 1-1/2" cap screws, lockwashers and nuts. One cap screw should already be in place.
8. Tighten all of the main frame and rear mounting bracket cap screws evenly and securely.
9. Mount the wheel guards on the outside of fenders using cap screws furnished with tractor.

DEALER PREDELIVERY SERVICE RECOMMENDATIONS

NOTE

Proper servicing of the loader before delivery to the owner is your best insurance against costly service calls.

1. Fill the reservoir with Wagner Special Hydraulic Fluid or approved equal.

NOTE

Efficient operation of any hydraulic system depends to a large extent on CLEAN OIL. Always be careful when servicing the hydraulic system to prevent dirt or foreign materials from entering.

2. Lubricate all fittings, using a quality chassis lubricant.
3. Start the tractor engine.
4. Operate both the lift and attachment cylinders.
5. If the oil becomes foamy during the run-in operation, operate all cylinders to their full stroke several more times. If the loader has single-acting lift cylinders, it is possible for a pocket of air to become trapped in the cylinders. This condition is best overcome by dropping the rod end of the cylinders and slowly filling the tubes with oil through the 3/8" hose connection at the cylinder base. Should oil continue to leak from the breather cap, check for an air leak at the front mounted pump inlet side connections using a soap solution. Use only approved oils in the system.
6. With all cylinders in a closed position, check the oil level in the reservoir. The proper level for a loader mounted independently is approximately 4" below the base of the filler pipe. Add oil if necessary to bring up to the proper level.

NOTE

Do not lower the dipperstick or dump attachment unless the tractor is running, since in doing so, the pump cannot supply oil for displacement in the double-acting cylinders.

As a result the oil level in the reservoir will rise excessively and may overflow at the breather cap.

7. Check the tightness of the set screws in the flexible drive coupling.
8. Care should be taken when tightening the hose connections to prevent twisting. If a hose appears twisted, straighten it out immediately because it may burst under high operating pressures.
9. Check the tightness of the mounting bolts.

CHECKING OPERATING PRESSURE

Check the operating pressure before delivering the loader to the customer.

Install a pressure gauge in the high pressure line between the pump and the control valve.

NOTE

Use a pressure gauge rated at 3000 lbs. per square inch capacity.

With the tractor running at full throttle, operate the loader lift cylinders to full stroke and briefly hold the control lever open to cause the relief valve to by-pass. Check the pressure reading on the gauge. The gauge reading must not be in excess of 1950 PSI or less than 1850 PSI on the H805-42 valve. The gauge reading must not be in excess of 1750 PSI or less than 1650 PSI on the H805-43 valve. The operating pressure can be adjusted if necessary by removing the cover from the bushing and plug on the right side of the control valve. To decrease the operating pressure, tighten the bushing and plug. If a leak results when making the pressure adjustments, shut off the tractor and remove the hose from the dump port of the valve. Place a container under the nipple at the valve dump port and remove the relief assembly. The relief ball and spring guide may drop through the nipple. Apply fresh pipe thread sealer to the bushing and plug, reseal the relief ball and guide spring and tighten until the recommended pressure is obtained.

PARTS LIST

WAGNER MODEL 100, 110, 130, 150 AND 200 POW'R

LOAD'RS

FOR

FORD 2N, 8N, 9N, NAA, 600 AND 800

SERIES TRACTORS

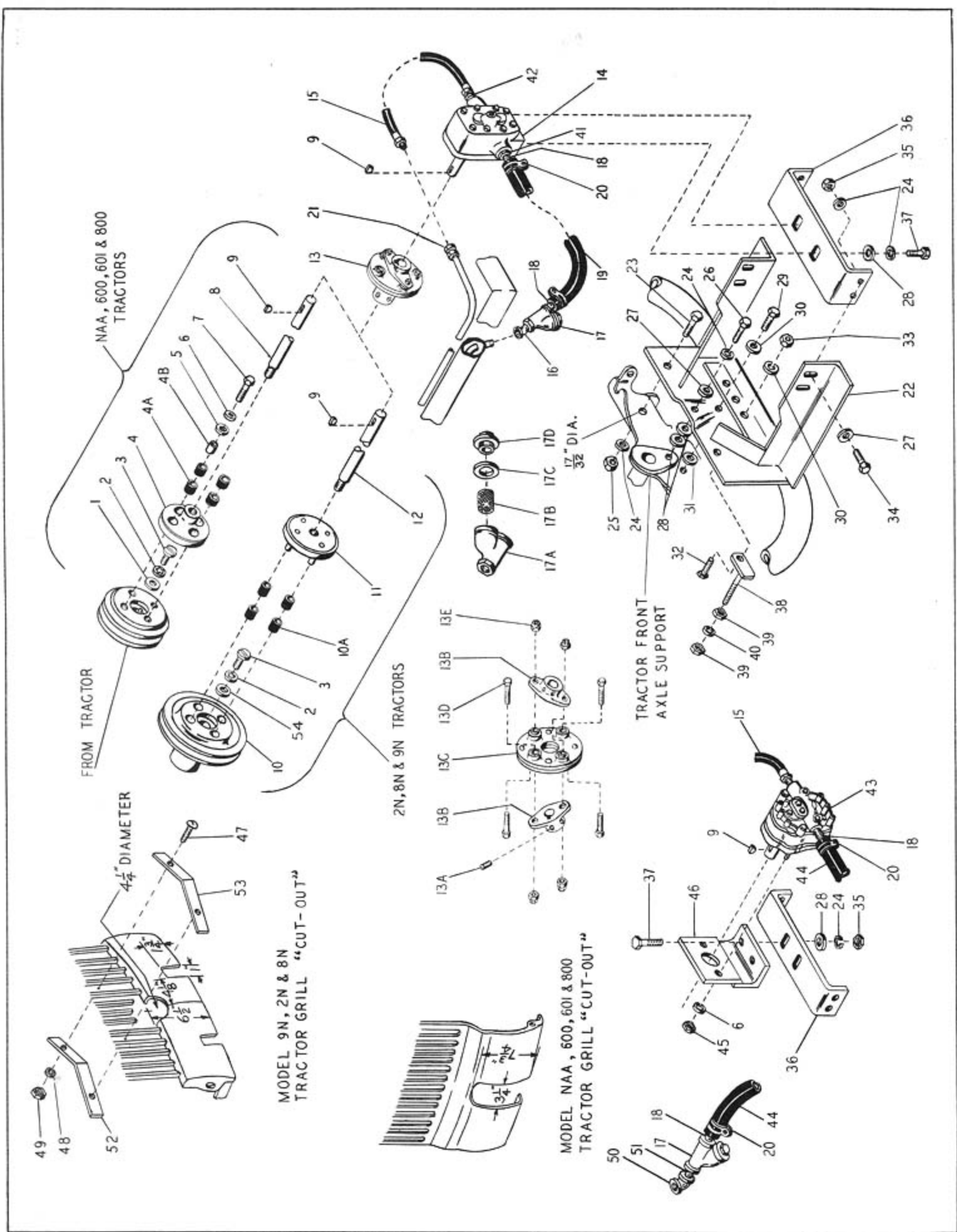

Figure 1, Pump Mounting and Drive Assembly

PARTS LIST, FIGURE 1, PUMP MOUNTING AND DRIVE ASSEMBLY CONNECTIONS

| <u>INDEX NO.</u> | <u>PART NO.</u> | <u>DESCRIPTION</u> | <u>QTY.</u> |
|------------------|-----------------|------------------------------------------|-------------|
| 1 | L97-62 | Special Washer 3/16" Thick | 1 |
| 2 | L97-161 | Internal Lockwasher | 1 |
| 3 | L80-6 | Special Screw | 1 |
| 4 | L604-41 | Adapter Assembly | 1 |
| 4A | L6-12 | Rubber Bushing | 4 |
| 4B | L6-11 | Steel Bushing | 4 |
| 5 | H97-3 | Special Washer | 4 |
| 6 | Z97-158 | 7/16" Internal Shakeproof Lockwasher | 4 |
| 7 | Z80-58 | 7/16"-14 x 1-1/2" Hex Head Cap Screw | 4 |
| 8 (1) | L83-32 | Drive Shaft | 1 |
| 9 | Z53-10 | #9 Woodruff Key | 2 |
| 10 | L604-48 | Sheave Assembly | 1 |
| 10A | L6-9 | Rubber Bushing | 4 |
| 11 | L608-3 | Hub and Pin Assembly | 1 |
| 12 (2) | L83-8 | Drive Shaft | 1 |
| 13 | L601-9 | Flexible Coupling Assembly | 1 |
| 13A | Z80-7001 | 1/4"-20 x 1/4" Socket Head Set Screw | 2 |
| 13B | L36-1 | Flange 3/4" Bore | 2 |
| 13C | L52-10 | Center Assembly | 1 |
| 13D | L80-7 | 5/16"-24 x 1-5/8" Hex Head Cap Screw | 4 |
| 13E | L61-5 | 5/16"-24 Stop Nut | 4 |
| 14 | L827-10 | Pump Assembly, 14 G.P.M. | 1 |
| 15 | H801-11 | 1/2" x 16-3/4" Hose Assembly | 1 |
| 16 | Z68-255 | 3/4" x 45° Street Elbow | 1 |
| 17 | H803-1 | "Y" Strainer Assembly | 1 |
| 17A | H51-6 | "Y" Fitting | 1 |
| 17B | H35-1 | Screen | 1 |
| 17C | H40-9 | Gasket | 1 |
| 17D | H20-2 | Cap | 1 |
| 18 | L60-31 | 3/4" x 1-3/4" T.O.E. Nipple | 2 |
| 19 (3) | L50-29 | 1" I.D. x 13" Neoprene Hose | 1 |
| 20 | L22-37 | 1" x 5W Hose Clamp | 2 |
| 21 | L825-7 | 1/2" Adapter Union F.F. | 1 |
| 22 | L502-75 | Front Mounting Bracket | 1 |
| 23 | Z80-575 | 1/2"-20 N.F. x 1-1/4" Hex Head Cap Screw | 2 |
| 24 | Z97-32 | 1/2" Lockwasher | 9 |
| 25 | Z61-555 | 1/2" - 20 Hex Nut | 2 |
| 26 | Z80-577 | 1/2"-20 N.F. x 1-3/4" Hex Head Cap Screw | 1 |
| 27 | Z97-506 | 1/2" Plain Washer | 5 |
| 28 (4) | L97-20 | Special Washer, 3/16" Thick | 4 |
| 29 (1) | Z80-608 | 5/8"-18 x 1-1/2" Hex Head Cap Screw | 1 |
| 30 (4) | Z97-38 | 5/8" Lockwasher | 4 |
| 31 (1) | L97-13 | Special Washer, 1/4" Thick | 1 |
| 32 | Z80-611 | 5/8"-18 N.F. x 2-1/4" Hex Head Cap Screw | 2 |
| 33 | Z61-557 | 5/8" - 18 Hex Nut | 2 |
| 34 | Z80-76 | 1/2"-13 x 1-1/2" Hex Head Cap Screw | 4 |
| 35 | Z61-305 | 1/2" - 13 Hex Nut | 6 |
| 36 | L15-178 | Pump Mounting Bracket | 1 |
| 37 | Z80-75 | 1/2"-13 x 1-1/4" Hex Head Cap Screw | 2 |
| 38 (5) | L509-24 | Tie Bar Bracket | 2 |
| 39 (5) | Z61-308 | 3/4" - 10 Hex Nut | 4 |
| 40 (5) | Z97-44 | 3/4" Lockwasher | 2 |
| 41 | Z68-664 | 3/4" x 1" Hex Bushing | 1 |
| 42 | Z68-660 | 1/2" x 3/4" Hex Bushing | 1 |
| 43 | L827-12 | Pump Assembly, 17 G.P.M. | 1 |

| <u>INDEX NO.</u> | <u>PART NO.</u> | <u>DESCRIPTION</u> | <u>QTY.</u> |
|------------------|-----------------|-------------------------------------------|-------------|
| 44 (3) | L50-29 | 1" I.D. x 15" Neoprene Hose | 1 |
| 45 | Z61-304 | 7/16" - 14 Hex Nut | 2 |
| 46 | L502-609 | Pump Bracket | 1 |
| 47 | Z80-1306 | 1/4"-20 x 1-1/4" Round Head Machine Screw | 2 |
| 48 | Z97-20 | 1/4" Lockwasher | 2 |
| 49 | Z61-301 | 1/4" - 20 Hex Nut | 2 |
| 50 | Z68-225 | 3/4" x 45° Pipe Elbow | 1 |
| 51 | Z60-86 | 3/4" Close Nipple | 1 |
| 52 (2) | L22-5 | Inside Grill Strap | 1 |
| 53 (2) | L22-4 | Outside Grill Strap | 1 |
| 54 | L97-12 | Special Washer, 3/32" Thick | 1 |

- (1) For Model NAA, 600 and 800 Series Tractors only.
- (2) For Model 2N, 8N and 9N Series Tractors only.
- (3) Please specify length in feet when ordering.
- (4) Quantity required is one less for Model 2N, 8N and 9N Tractors.
- (5) Optional for Model 110 Loader.

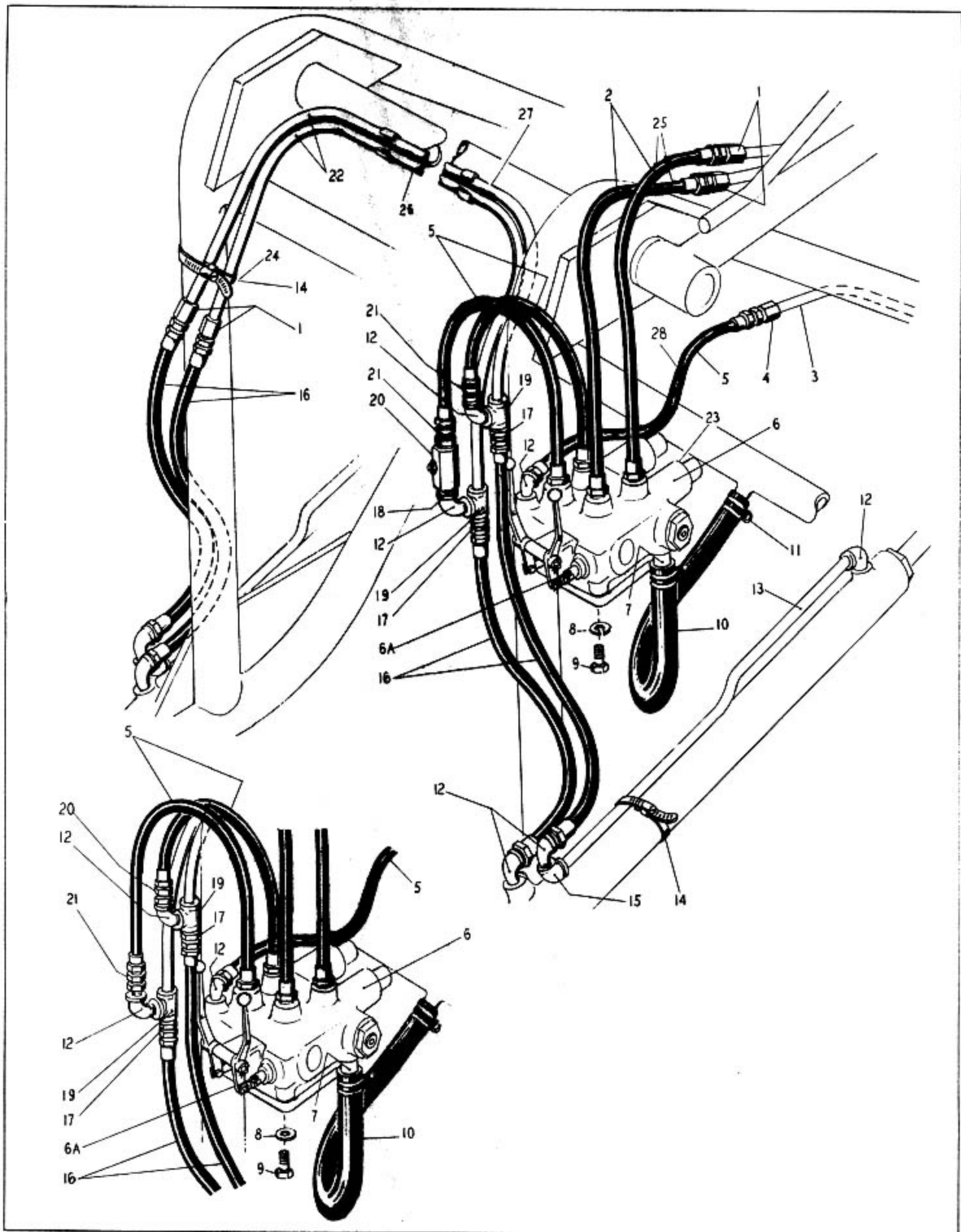

Figure 2, Hydraulic Connections for Models 110D, 130, 150 and 200 Loaders

PARTS LIST, FIGURE #2, HYDRAULIC CONNECTIONS FOR MODELS 110D, 130, 150 AND 200 LOADERS.

| <u>INDEX NO.</u> | <u>PART NO.</u> | <u>DESCRIPTION</u> | <u>QTY.</u> |
|------------------|-----------------|-------------------------------------|-------------|
| 1 | L825-5 | 3/8" Adapter Union F.F. | 4 |
| 2 (2) | H801-25 | 3/8" x 1/2" x 18-3/4" Hose Assembly | 2 |
| 3 | L63-259 | 1/2" x 50" Oil Line, Pressure Feed | 1 |
| 4 | L825-7 | 1/2" Adapter Union F.F. | 1 |
| 5 (5) | H801-11 | 1/2" x 22-3/4" Hose Assembly | 3 |
| 6 (1) | H805-42 | Duplex Valve Assembly | 1 |
| 6A(1) | L609-56 | Valve Handle Kit | 1 |
| 7 | L60-31 | 3/4" x 1-3/4" T.O.E. Nipple | 1 |
| 8 | Z97-23 | 5/16" Lockwasher | 3 |
| 9 | Z80-18 | 5/16"-18 x 3/4" Hex Hd. Cap Screw | 3 |
| 10 (3) | L50-29 | 1" I.D. x 18" Neoprene Hose | 1 |
| 11 | L22-37 | 1" x 5W Hose Clamp | 2 |
| 12 | Z68-204 | 1/2" x 90° Street Elbow | 9 |
| 13 | L63-284 | 1/2" x 29" Oil Line, Cylinder | 2 |
| 14 | L22-23 | Line Clamp, 12S | 3 |
| 15 | Z68-4 | 1/2" x 90° Elbow | 2 |
| 16 | H801-27 | 3/8" x 1/2" x 22-3/4" Hose Assembly | 4 |
| 17 | L825-4 | 3/8" Adapter Union F.M. | 2 |
| 18 (4) | Z60-64 | 1/2" Close Nipple | 1 |
| 19 | Z68-758 | 3/8" x 3/8" x 1/2" Pipe Tee | 2 |
| 20 (4) | L805-10 | Flow Control Valve | 1 |
| 21 | L825-8 | 1/2" Adapter Union F.M. | 2 |
| 22 | L63-281 | 3/8" x 50" Oil Line, Equalizer | 2 |
| 23 (2) | H805-74 | Duplex Valve Assembly | 1 |
| 24 | L22-76 | Line Clamp, 13S | 1 |
| 25 (1) | H801-26 | 3/8" x 1/2" x 20-3/4" Hose Assembly | 2 |
| 25A(6) | H801-10 | 3/8" x 1/2" x 16-3/4" Hose Assembly | 2 |
| 26 (2) | L63-287 | 3/8" x 25-1/2" Oil Line, Equalizer | 1 |
| 27 (2) | L63-288 | 3/8" x 29" Oil Line, Equalizer | 1 |
| 28 (4) | H801-22 | 1/2" x 18" Hose Assembly | 1 |

- (1) For Models 110D, 130 and 150 Loaders only.
- (2) For Model 200 Loaders only.
- (3) Please specify length in feet when ordering.
- (4) For Models 110D, 150 and 200 Loaders only.
- (5) Quantity is one (1) less for Models 110D, 150 and 200 Loaders.
- (6) For Model 110D Loader only.

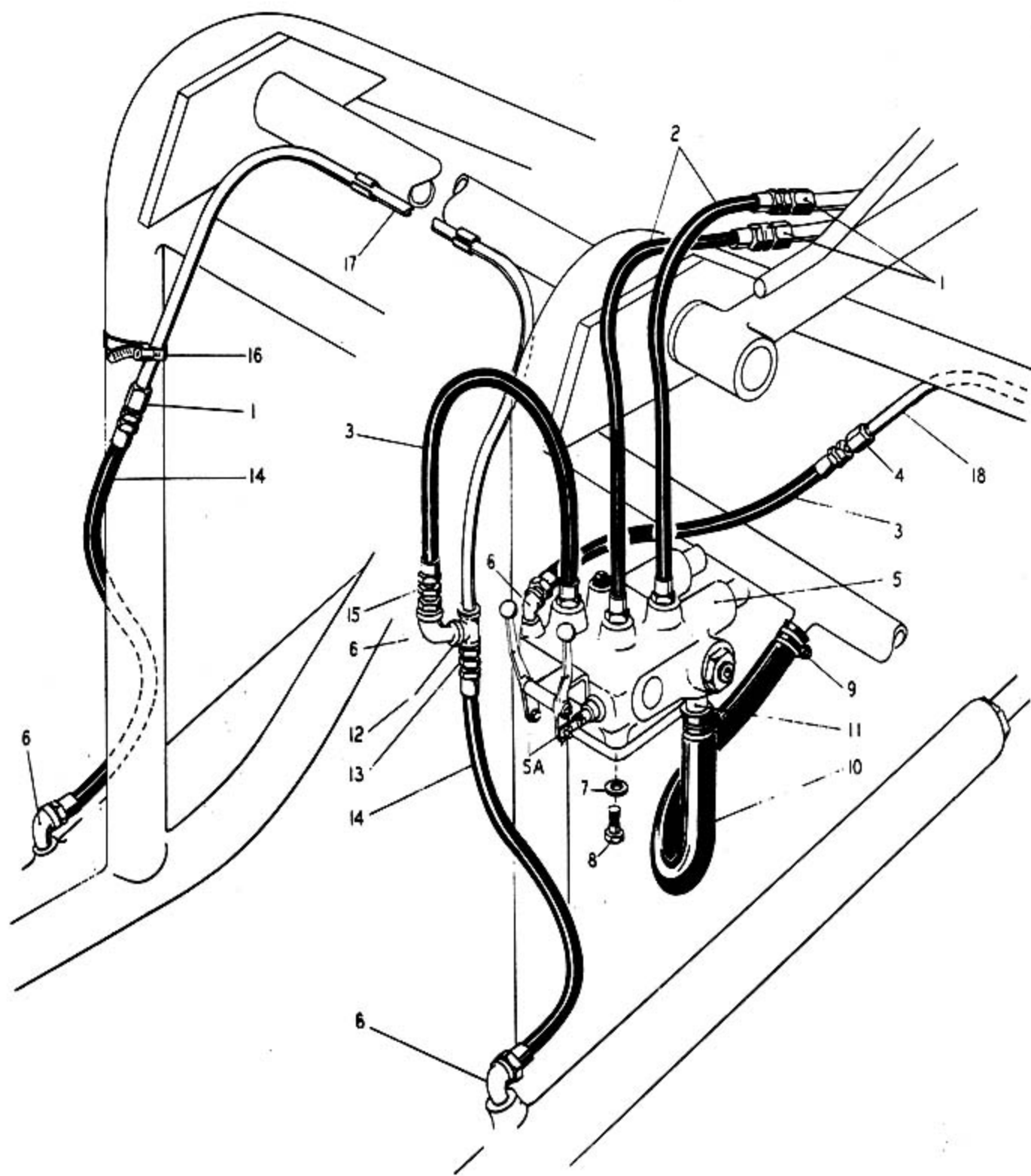

Figure 3, Hydraulic Connections for Models 100 and 110S Loaders

PARTS LIST, FIGURE #3, HYDRAULIC CONNECTIONS FOR MODELS 100 and 110S LOADERS.

| <u>INDEX NO.</u> | <u>PART NO.</u> | <u>DESCRIPTION</u> | <u>QTY.</u> |
|------------------|-----------------|-------------------------------------|-------------|
| 1 | L825-5 | 3/8" Adapter Union F.F. | 3 |
| 2 | H801-10 | 1/2" x 3/8" x 16-3/4" Hose Assembly | 2 |
| 3 | H801-11 | 1/2" x 16-3/4" Hose Assembly | 2 |
| 4 | L825-7 | 1/2" Adapter Union F.F. | 1 |
| 5 | H805-43 | Duplex Valve Assembly | 1 |
| 5A | L609-56 | Control Valve Handle Kit | 1 |
| 6 | Z68-204 | 1/2" x 90° Street Elbow | 4 |
| 7 | Z97-23 | 5/16" Lockwasher | 3 |
| 8 | Z80-18 | 5/16"-18 x 3/4" Hex Head Cap Screw | 3 |
| 9 | L22-37 | 1" x 5W Hose Clamp | 2 |
| 10 * | L50-29 | 1" I.D.x18" Neoprene Hose | 1 |
| 11 | L60-31 | 3/4" x 1-3/4" T.O.E. Nipple | 1 |
| 12 | Z68-758 | 3/8" x 3/8" x 1/2" Pipe Tee | 1 |
| 13 | L825-4 | 3/8" Adapter Union F.M. | 1 |
| 14 | H801-27 | 3/8" x 1/2" x 22-3/4" Hose Assembly | 2 |
| 15 | L825-8 | 1/2" Adapter Union F.M. | 1 |
| 16 | L22-23 | Line Clamp #12S | 1 |
| 17 | L63-281 | 3/8" x 50" Oil Line, Equalizer | 1 |
| 18 | L63-259 | 1/2" x 50" Oil Line, Pressure Feed | 1 |

* Please specify length in feet when ordering.

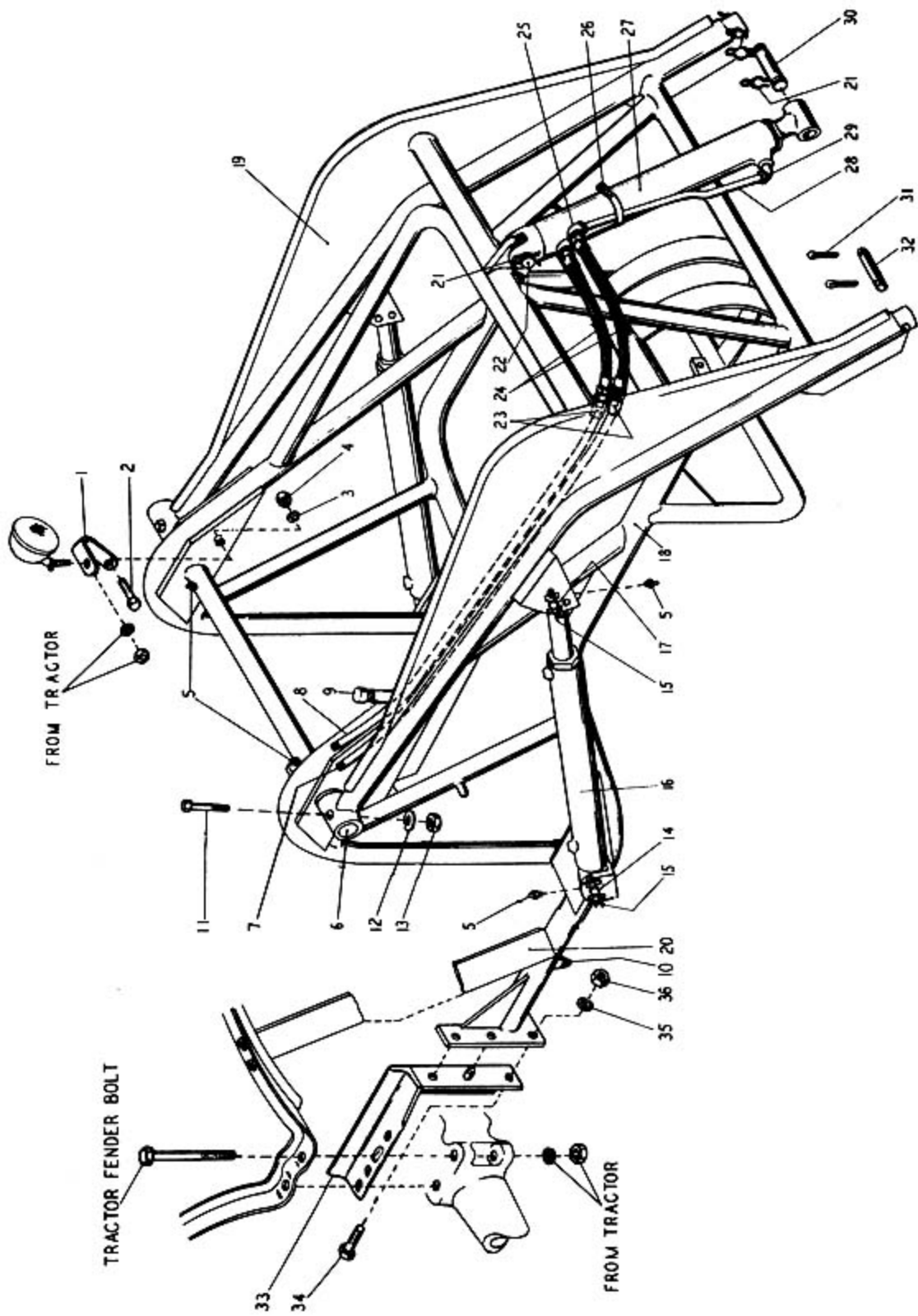

Figure 4, Mainframe, Dipperstick and Attachment Cylinder Connections for Models 100 and 130 Loaders

PARTS LIST, FIGURE #4, MAINFRAME, DIPPERSTICK AND FRONT HYDRAULICS FOR MODELS 100 AND 130 LOADERS.

| <u>INDEX NO.</u> | <u>PART NO.</u> | <u>DESCRIPTION</u> | <u>QTY.</u> |
|------------------|-----------------|------------------------------------------------|-------------|
| 1 | L15-317 | Headlight Mounting Bracket | 2 |
| 2 | Z80-75 | 1/2"-13 x 1-1/4" Hex Head Cap Screw | 2 |
| 3 | Z97-32 | 1/2" Lockwasher | 2 |
| 4 | Z61-305 | 1/2" - 13 Hex Nut | 2 |
| 5 | L56-1 | Grease Fitting - Straight | 6 |
| 6 | L78-23 | 1-7/8" x 41-1/4" Pivot Rod | 1 |
| 7 | L63-277 | 3/8" x 53" Oil Line | 1 |
| 8 | L63-278 | 3/8" x 53" Oil Line | 1 |
| 9 | L20-19 | Breather Cap | 1 |
| 10 | Z68-1104 | 1/2" Pipe Plug | 1 |
| 11 | Z80-117 | 5/8"-11 x 3-3/4" Hex Head Cap Screw | 2 |
| 12 | Z97-38 | 5/8" Lockwasher | 2 |
| 13 | Z61-307 | 5/8" - 11 Hex Nut | 2 |
| 14 | L67-33 | 1" x 5" Pin | 2 |
| 15 | Z67-132 | 3/8" x 2-1/2" Cotter Pin | 4 |
| 16 | H800-75 | Double Acting Cylinder Assembly(Model 100) | 2 |
| | H800-46 | Double Acting Cylinder Assembly(Model 130) | 2 |
| 17 | L67-41 | 1" x 4" Pin | 2 |
| 18 | L605-113 | Main Frame Assembly | 1 |
| 19 | L602-35 | Dipperstick Assembly | 1 |
| 20 | L43-16 | Wheel Guard | 2 |
| 21 | L77-21 | 3/4" Retainer Spring | 4 |
| 22 | L67-173 | 3/4" x 3-3/16" Pin | 1 |
| 23 | L825-5 | 3/8" Adapter Union F.F. | 2 |
| 24 | H801-26 | 1/2" x 3/8" x 20-3/4" Hose Assembly(Model 100) | 2 |
| | H801-10 | 3/8" x 1/2" x 16-3/4" Hose Assy.(Model 130) | 2 |
| 25 | Z68-4 | 1/2" x 90° Elbow | 1 |
| 26 | L22-23 | Line Clamp, 12S | 1 |
| 27 | H800-51 | Double Acting Cylinder Assembly | 1 |
| 28 | L63-275 | 1/2" x 17" Oil Line | 1 |
| 29 | Z68-204 | 1/2" x 90° Street Elbow | 1 |
| 30 | L67-174 | 3/4" x 4-1/2" Pin | 1 |
| 31 | Z67-118 | 5/16" x 2" Cotter Pin | 4 |
| 32 | L67-38 | 1" x 5" Pin | 2 |
| 33 | L502-460 | R.H. Rear Mounting Bracket | 1 |
| * | L502-459 | L.H. Rear Mounting Bracket | 1 |
| 34 | Z80-128 | 3/4" - 10 x 2" Hex Head Cap Screw | 4 |
| 35 | Z97-44 | 3/4" Lockwasher | 4 |
| 36 | Z61-308 | 3/4" - 10 Hex Nut | 4 |

* Not shown on drawing.

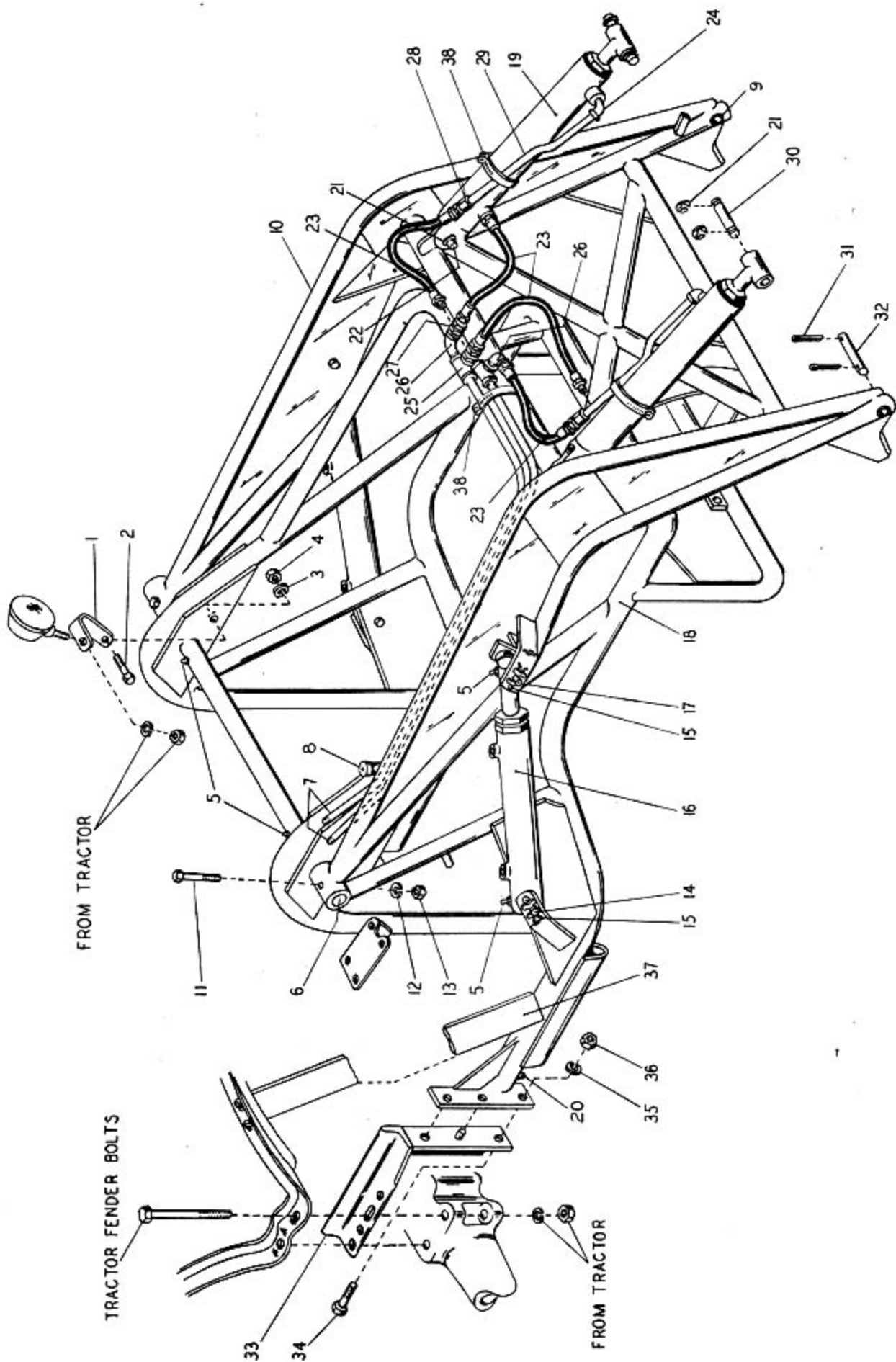

Figure 5, Mainframe and Dipperstick Assembly for Model 200 and Attachment Cylinder Connections for Models 150 and 200 Loaders

PARTS LIST, FIGURE #5, MAINFRAME AND DIPPERSTICK ASSEMBLY FOR MODEL 200 AND ATTACHMENT CYLINDER CONNECTIONS FOR MODELS 150 AND 200 LOADERS.

| <u>INDEX NO.</u> | <u>PART NO.</u> | <u>DESCRIPTION</u> | <u>QTY.</u> |
|------------------|-----------------|-------------------------------------|-------------|
| 1 | L15-317 | Headlight Mounting Bracket | 2 |
| 2 | Z80-75 | 1/2"-13 x 1-1/4" Hex Head Cap Screw | 2 |
| 3 | Z97-32 | 1/2" Lockwasher | 2 |
| 4 | Z61-305 | 1/2" - 13 Hex Nut | 2 |
| 5 | L56-1 | Grease Fitting - Straight | 6 |
| 6 | L78-23 | 1-7/8" x 41-1/4" Pivot Rod | 1 |
| 7 | L63-282 | 3/8" x 67" Oil Line | 2 |
| 8 | L20-19 | Breather Cap | 1 |
| 9 | L86-60 | Pivot Sleeve | 2 |
| 10 | L602-46 | Dipperstick Assembly(Model 200) | 1 |
| 11 | Z80-117 | 5/8"-11 x 3-3/4" Hex Head Cap Screw | 2 |
| 12 | Z97-38 | 5/8" Lockwasher | 2 |
| 13 | Z61-307 | 5/8" - 11 Hex Nut | 2 |
| 14 | L67-4 | 1" x 6-1/4" Pin (Model 200) | 2 |
| 15 | Z67-132 | 3/8" x 2-1/2" Cotter Pin | 4 |
| 16 | H800-46 | Double Acting Cylinder Assembly | 2 |
| 17 | L67-33 | 1" x 5" Pin | 2 |
| 18 | L605-111 | Main Frame Assembly (Model 200) | 1 |
| 19 | H800-51 | Double Acting Cylinder Assembly | 2 |
| 20 | Z68-1104 | 1/2" Pipe Plug | 1 |
| 21 | L77-21 | 3/4" Retainer Ring | 8 |
| 22 | L67-173 | 3/4" x 3-5/16" Pin | 2 |
| 23 | H801-25 | 3/8" x 1/2" x 18-3/4" Hose Assembly | 4 |
| 24 | Z68-204 | 1/2" x 90° Street Elbow | 2 |
| 25 | Z68-303 | 3/8" Pipe Tee | 2 |
| 26 | Z68-203 | 3/8" x 90° Street Elbow | 2 |
| 27 | L825-4 | 3/8" Adapter Union F.M. | 2 |
| 28 | L825-7 | 1/2" Adapter Union F.F. | 2 |
| 29 | L63-375 | 1/2" x 17" Oil Line | 2 |
| 30 | L67-174 | 3/4" x 4-5/8" Pin | 2 |
| 31 | Z67-118 | 5/16" x 2" Cotter Pin | 4 |
| 32 | L67-38 | 1" x 5" Pin | 2 |
| 33 | L502-460 | R.H. Rear Mounting Bracket | 1 |
| * | L502-459 | L.H. Rear Mounting Bracket | 1 |
| 34 | Z80-128 | 3/4"-10 x 2" Hex Head Cap Screw | 4 |
| 35 | Z97-44 | 3/4" Lockwasher | 4 |
| 36 | Z61-308 | 3/4" - 10 Hex Nut | 4 |
| 37 | L43-16 | Wheel Guard | 2 |
| 38 | L22-23 | Line Clamp, 12S | 3 |

* Not Shown on Drawing.

PARTS LIST, FIGURE #6, MAINFRAME AND DIPPERSTICK ASSEMBLY FOR MODELS 110 AND 150 LOADERS.

| <u>INDEX NO.</u> | <u>PART NO.</u> | <u>DESCRIPTION</u> | <u>QTY.</u> |
|------------------|-----------------|----------------------------------------|-------------|
| 1 | L15-317 | Light Bracket | 2 |
| 2 | Z80-75 | 1/2"-13 x 1-1/4" Hex Head Cap Screw | 2 |
| 3 | Z97-32 | 1/2" Lockwasher | 2 |
| 4 | Z61-305 | 1/2" - 13 Hex Nut | 2 |
| 5 | L602-81 | Dipperstick Assembly (Model 110) | 1 |
| 5A | L602-36 | Dipperstick Assembly (Model 150) | 1 |
| 6 | Z67-118 | 5/16" x 2" Cotter Pin | 4 |
| 7 | L67-38 | 1" x 5" Pin | 2 |
| 8 | L605-195 | Mainframe Assembly (Model 110) | 1 |
| 8A | L605-158 | Mainframe Assembly (Model 150) | 1 |
| 9 | L56-1 | Grease Fittings | 6 |
| 10 | Z67-132 | 3/8" x 2-1/2" Cotter Pin | 4 |
| 11 | L67-41 | 1" x 4" Pin | 2 |
| 12 | H800-46 | Double Acting Cylinder Assembly - 110D | 2 |
| 12A | H800-75 | Single Acting Cylinder Assembly - 110S | 2 |
| 13 | L67-33 | 1" x 5" Pin | 2 |
| 14 | Z61-308 | 3/4" - 10 Hex Nut | 4 |
| 15 | Z97-44 | 3/4" Lockwasher | 4 |
| 16 | Z68-1104 | 1/2" Pipe Plug | 1 |
| 17 | Z80-128 | 3/4"-10 x 2" Hex Head Cap Screw | 4 |
| 18 | L502-460 | R.H. Rear Mounting Bracket | 1 |
| * | L502-459 | L.H. Rear Mounting Bracket | 1 |
| 19 | L43-16 | Wheel Guard | 2 |
| 20 | L78-23 | Pivot Rod | 1 |
| 21 | L20-19 | Breather Cap | 1 |
| 22 | Z80-117 | 5/8"-11 x 3-3/4" Hex Head Cap Screw | 2 |
| 23 | Z97-38 | 5/8" Lockwasher | 2 |
| 24 | Z61-307 | 5/8" - 11 Hex Nut | 2 |
| 25 | L611-152 | 3/8" x 40" Oil Line | 1 |
| 26 | L611-153 | 3/8" x 38" Oil Line | 1 |
| 26A | L63-282 | 3/8" x 67" Oil Line | 2 |

* Not Shown on Drawing.

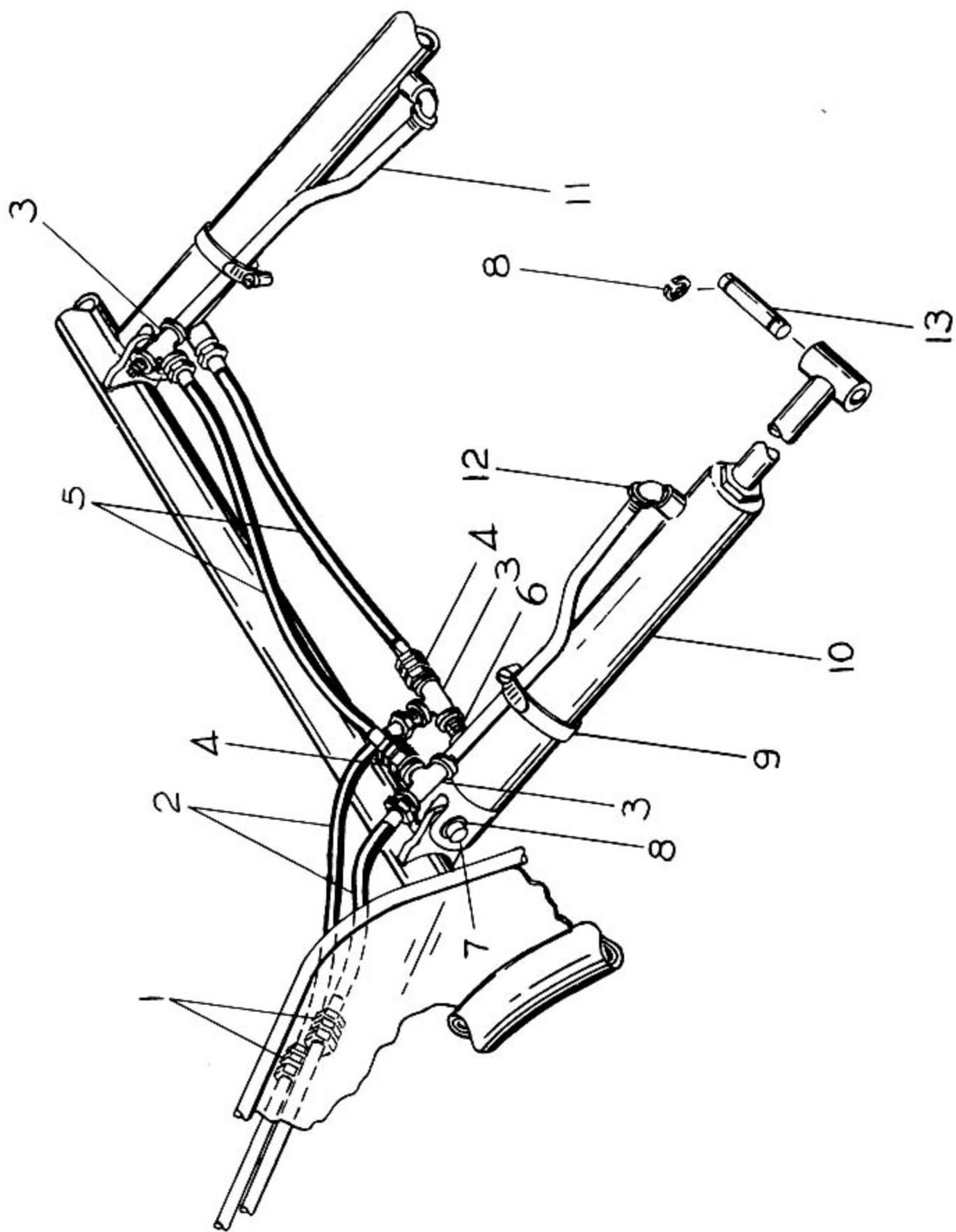
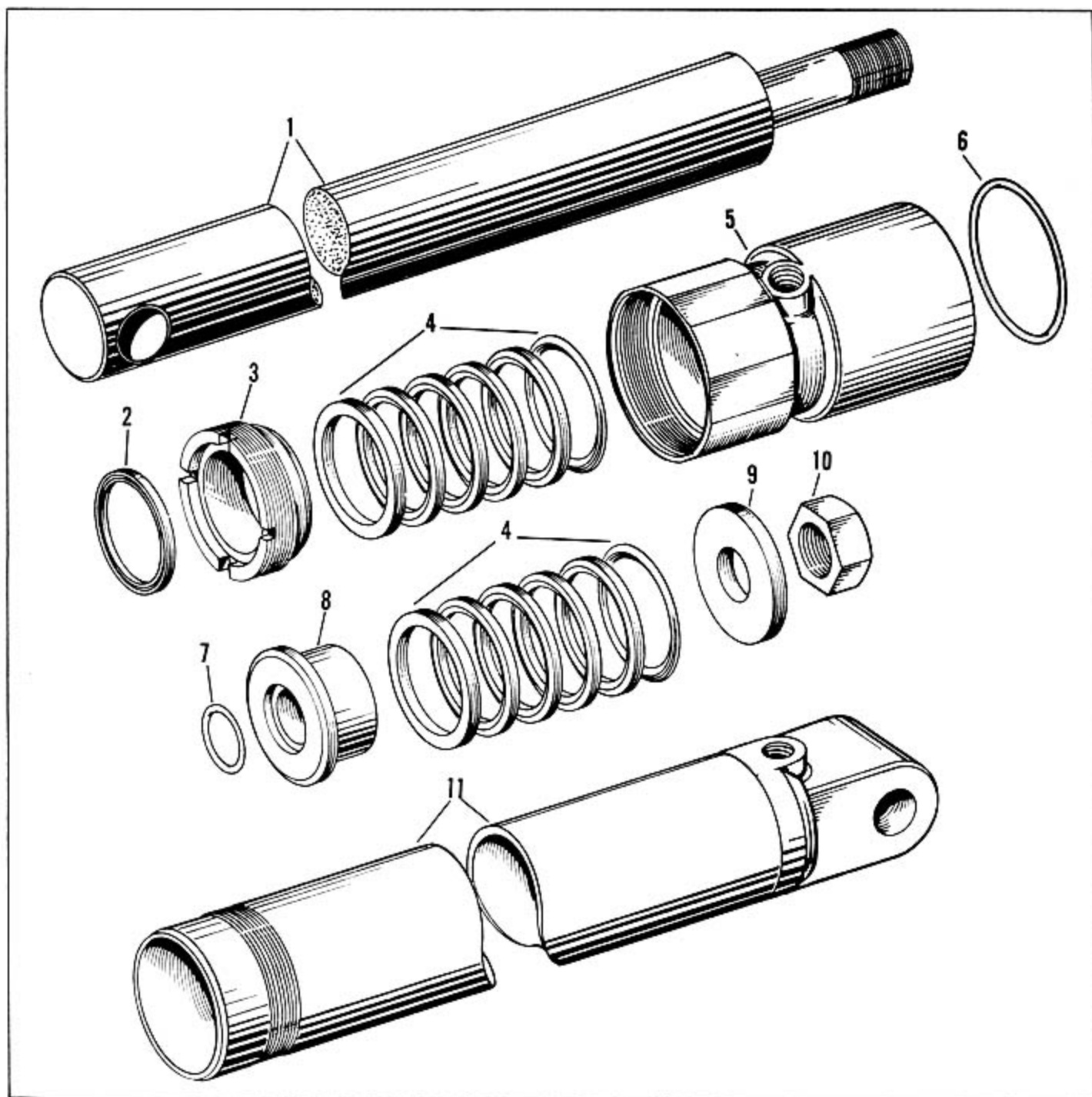

Figure 7, Attachment Cylinder Connections for Model 110 Loader

PARTS LIST, FIGURE #7, FRONT HYDRAULICS FOR MODEL 110 LOADER

| <u>INDEX NO.</u> | <u>PART NO.</u> | <u>DESCRIPTION</u> | <u>QTY.</u> |
|------------------|-----------------|-------------------------------------|-------------|
| 1 | L825-5 | 3/8" Adapter Union F.F. | 2 |
| 2 | H801-26 | 3/8" x 1/2" x 20-3/4" Hose Assembly | 2 |
| 3 | Z68-304 | 1/2" Pipe Tee | 3 |
| 4 | L825-8 | 1/2" Adapter Union F.M. | 2 |
| 5 | H801-56 | 1/2" x 23-1/2" Hose Assembly | 2 |
| 6 | Z60-64 | 1/2" Close Nipple | 1 |
| 7 | L67-173 | 3/4" x 3-5/16" Pin | 2 |
| 8 | L77-21 | 3/4" Retainer Spring | 8 |
| 9 | L22-23 | Line Clamp, 12S | 2 |
| 10 | H800-51 | Double Acting Cylinder Assembly | 2 |
| 11 | L63-375 | 1/2" x 17" Oil Line | 2 |
| 12 | Z68-204 | 1/2" x 90° Street Elbow | 2 |
| 13 | L67-33 | 1" x 5 " Pin | 2 |



DOUBLE ACTING CYLINDERS MODELS H800-46 AND H800-88

| Item | Part No. | Description | Qty. | Item | Part No. | Description | Qty. |
|------|----------|-------------|------|------|----------|---------------------------|------|
| 1 | H72-21 | Piston Rod | 1 | 7 | H62-39* | O Ring | 1 |
| 2 | H99-13* | Wiper Ring | 1 | 8 | H69-8 | Piston | 1 |
| 3 | H42-39 | Gland Nut | 1 | 9 | H69-7 | Piston Follower | 1 |
| 4 | H62-40* | Packing Set | 2 | 10 | H61-13 | Lock Nut | 1 |
| 5 | H42-38 | Gland Nut | 1 | 11 | H507-115 | Cyl. Tube Assy. (H800-46) | 1 |
| 6 | H62-74* | O Ring | 1 | | H507-124 | Cyl. Tube Assy. (H800-88) | 1 |

* The packings, wiper and O rings used in this cylinder are available as a complete repair kit under Part No. L 609-146

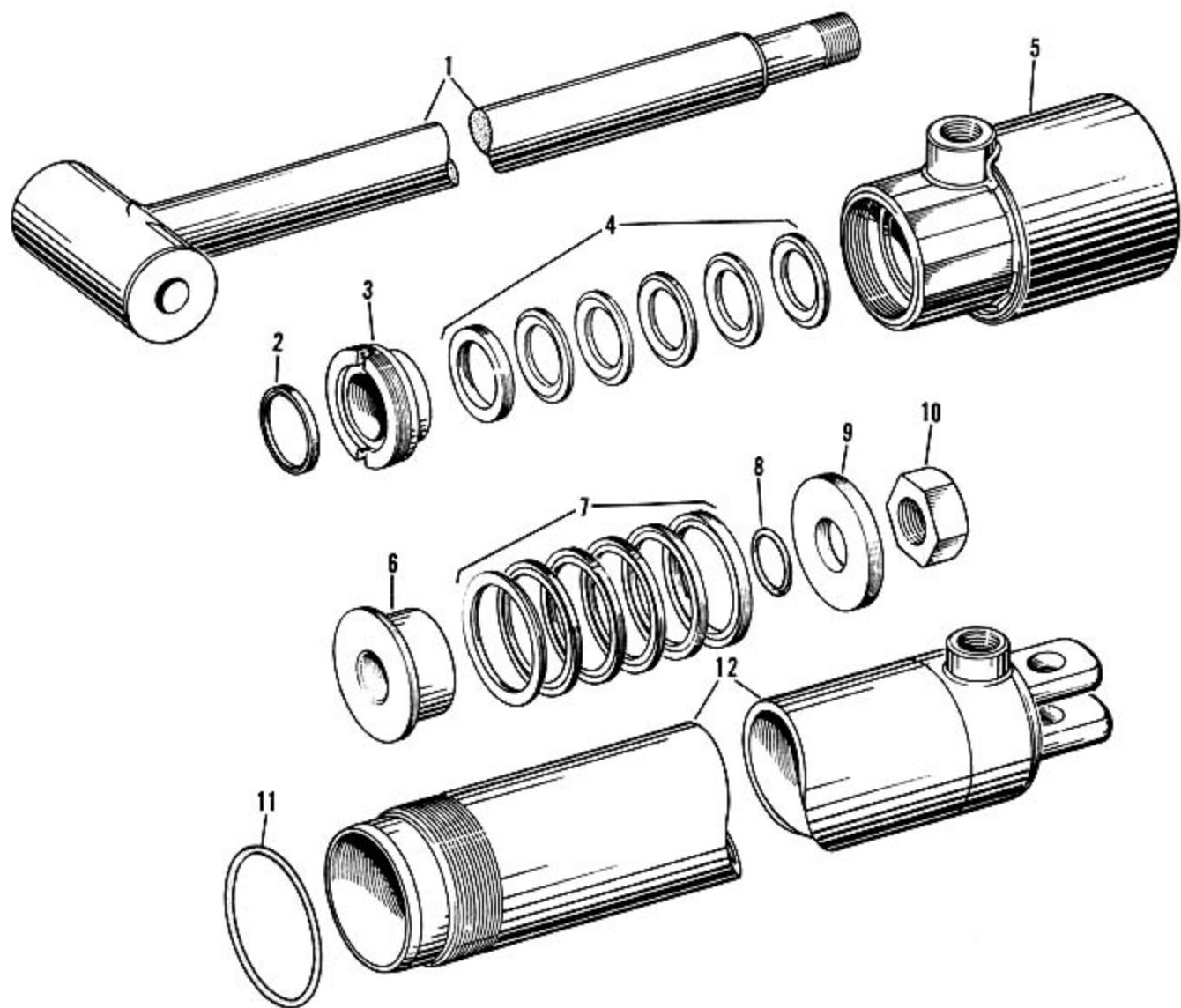

DOUBLE ACTING CYLINDERS MODEL NO. H800-51, H800-85 AND H800-87

| Item | Part No. | Description | Qty. | Item | Part No. | Description | Qty. |
|------|----------|--------------------------|------|------|----------|-----------------------------|------|
| 1 | H507-37 | Piston Rod Assy.-H800-51 | 1 | 7 | H62-40* | Packing | 1 |
| | H507-89 | Piston Rod Assy.-H800-85 | 1 | 8 | H62-39* | O Ring | 1 |
| | H507-47 | Piston Rod Assy.-H800-87 | 1 | 9 | H69-7 | Piston Follower | 1 |
| 2 | H99-12* | Wiper Ring | 1 | 10 | H61-13 | Lock Nut | 1 |
| 3 | H42-15 | Gland Nut | 1 | 11 | H62-74 | O Ring | 1 |
| 4 | H62-41* | Packing Set | 1 | 12 | H507-118 | Cylinder Tube Assy. H800-51 | 1 |
| 5 | H42-40 | Packing | 1 | | H507-121 | Cylinder Tube Assy. H800-85 | 1 |
| 6 | H69-6 | Piston | 1 | | H507-123 | Cylinder Tube Assy. H800-87 | 1 |

* The packings, wiper and O ring used in these cylinders are available as a complete repair kit under Part No. L609-145.

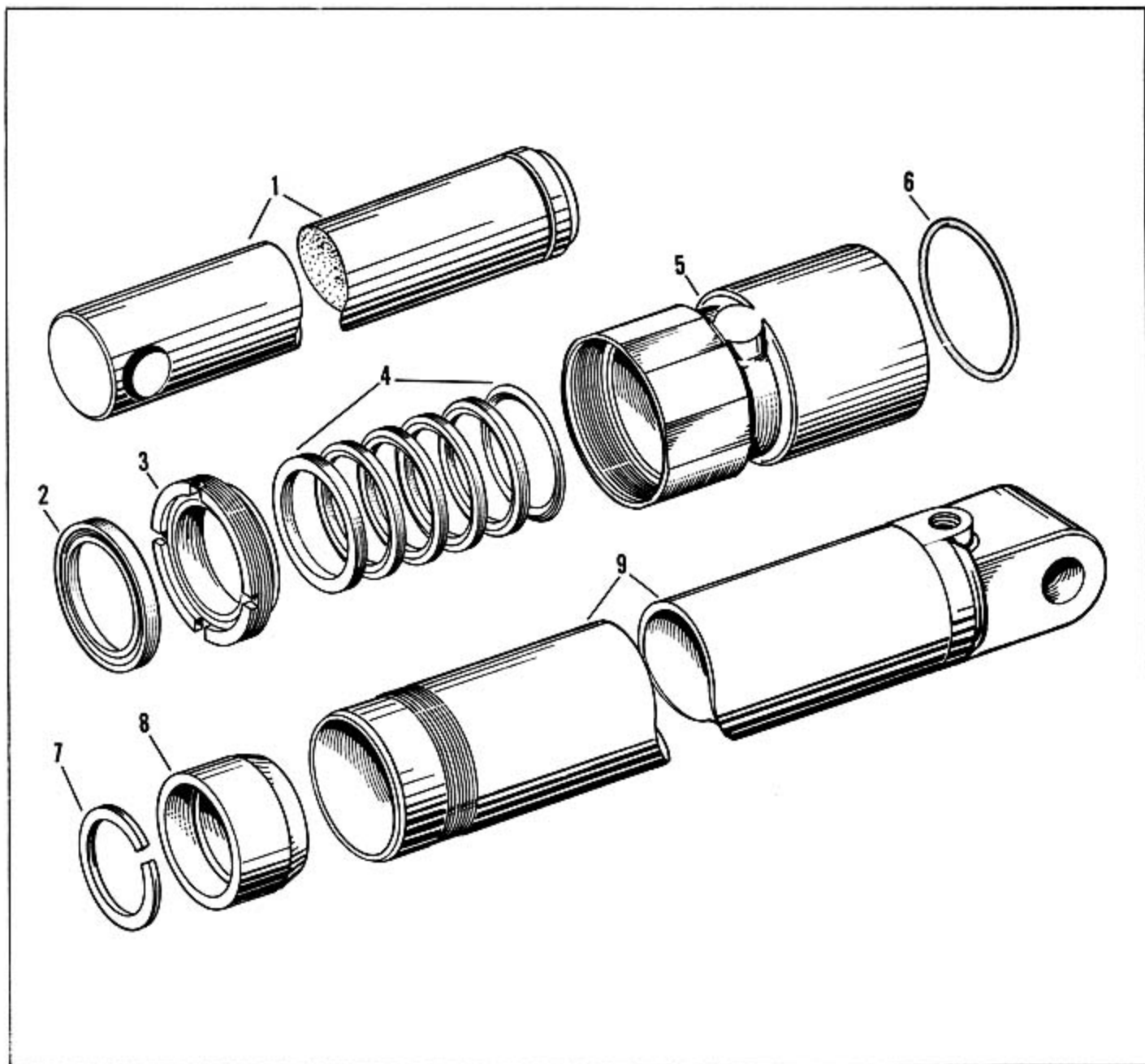

SINGLE ACTING CYLINDERS MODEL NOS. H800-75 AND H800-82

| Item | Part No. | Description | Qty. | Item | Part No. | Description | Qty. |
|------|----------|----------------------------|------|------|----------|---------------------------|------|
| 1 | H72-49 | Piston Rod (H800-75) | 1 | 5 | H42-41 | Gland Nut | 1 |
| | H613-29 | Piston Rod Assy. (H800-75) | 1 | 6 | H62-74* | O Ring | 1 |
| | H72-11 | Piston Rod (H800-82) | 1 | 7 | H87-2 | Snap Ring | 1 |
| | H613-6 | Piston Rod Assy. (H800-82) | 1 | 8 | H91-7 | Stop Plunger | 1 |
| 2 | H99-13* | Wiper Ring | 1 | 9 | H507-116 | Cyl. Tube Assy. (H800-75) | 1 |
| 3 | H42-39 | Gland Nut | 1 | | H507-117 | Cyl. Tube Assy. (H800-82) | 1 |
| 4 | H62-40* | Packing Set | 1 | | | | |

* The packings, wiper and O ring used in these cylinders are available as a complete repair kit under Part No. L 609-141.

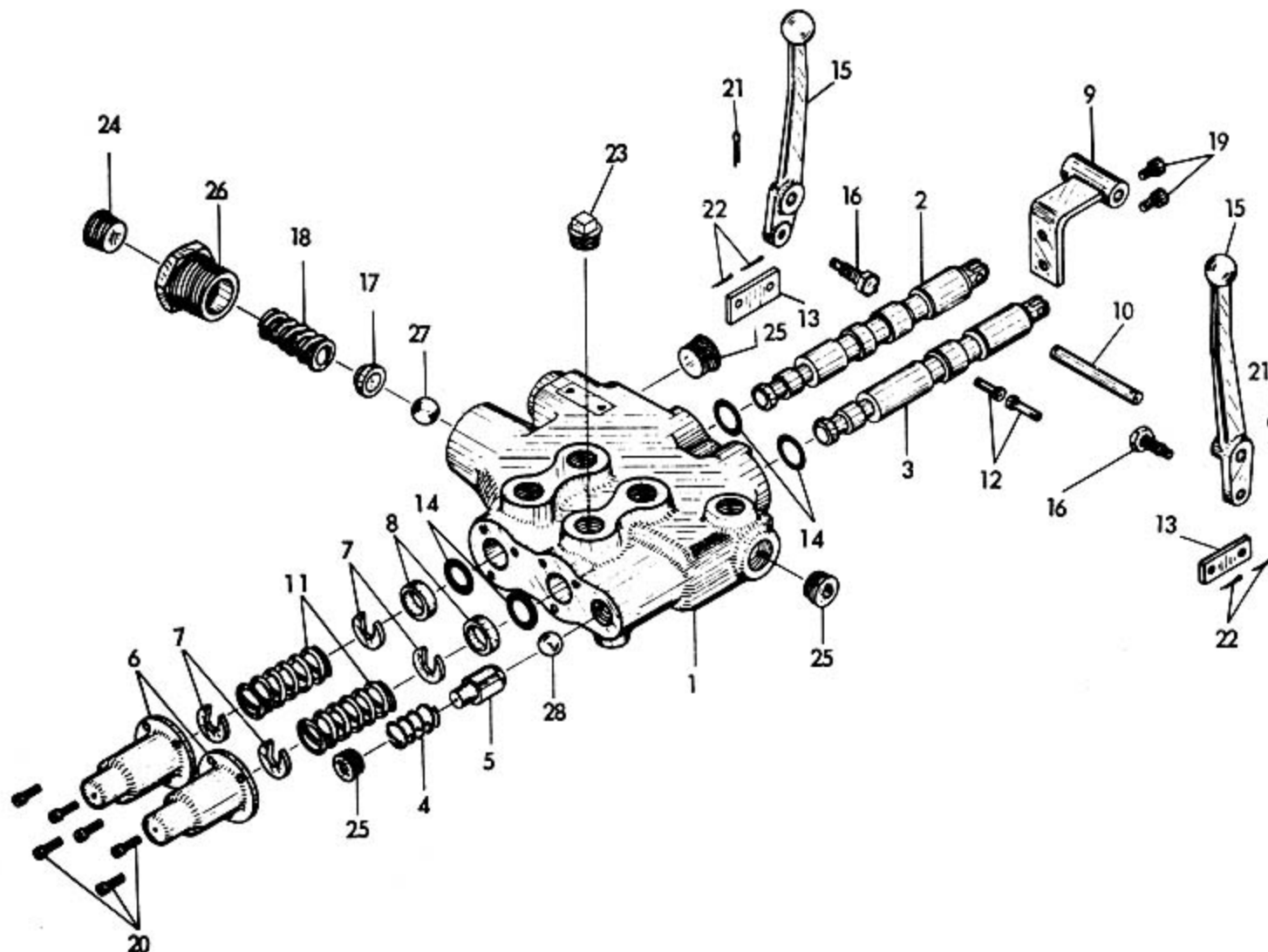

WAGNER "WONDERTROL" VALVE MODEL NO. H805-10

Single-Double Operation

Old Part No. 30300-3

| Item | Part No. | Description | Qty. |
|------|----------|-------------------------------------------------------------------------------------------------------------------------------------|------|
| | H805-10 | Wondertrol Valve Assy., Model No. H805-10, 1 S/A Spool, 1 D/A Spool, 1/2" Cylinder and Pressure Connections, 1/4" Return Connection | |
| 1 | H51-9 | Valve Body (1/2" Pressure Ports) | 1 |
| 2 | H89-9 | Spool - Double | 1 |
| 3 | H89-10 | Spool - Single | 1 |
| 4 | H90-6 | Check Valve Spring | 1 |
| 5 | H81-1 | Check Valve Guide | 1 |
| 6 | H20-1 | Spool Cover | 2 |
| 7 | H97-2 | C Washer | 4 |
| 8 | H23-6 | Spool Spacer | 2 |
| 9 | H507-21 | Hand Lever Bracket (Horizontal) | 1 |
| 11 | H90-5 | Spool Spring | 2 |

| Item | Part No. | Description | Qty. |
|------|----------|-----------------------------------|------|
| 12 | H67-3 | Link Pin | 2 |
| 13 | H55-2 | Link | 2 |
| 14 | H62-6 | O Ring | 4 |
| 17 | H81-2 | Spring Guide | 1 |
| 18 | H90-7 | Relief Spring | 1 |
| 19 | Z80-1853 | Socket Head Cap Screw | 2 |
| 20 | Z80-2009 | Socket Head Cap Screw | 6 |
| 23 | Z68-1104 | 1/2" N.P.T. Pipe Plug | 1 |
| 24 | Z68-1005 | 1/4" N.P.T. Socket Head Pipe Plug | 1 |
| 25 | Z68-1004 | 1/2" N.P.T. Socket Head Pipe Plug | 3 |
| 26 | H68-1 | Hex Bushing | 1 |
| 27 | H4-2 | Steel Ball | 1 |
| 28 | H4-4 | Steel Ball | 1 |

Wondertrol Valve Handle Kit

| Item | Part No. | Description | Qty. |
|------|----------|------------------------------------|------|
| | L609-25 | Handle Kit Complete consisting of: | |
| 10 | H67-4 | Lever Pin | 1 |
| 15 | H45-2 | Hand Lever | 2 |

| Item | Part No. | Description | Qty. |
|------|----------|-------------|------|
| 16 | H80-3 | Link Screw | 2 |
| 21 | Z67-19 | Cotter Pin | 2 |
| 22 | Z67-1 | Cotter Pin | 4 |

NOTE: This parts list supercedes Form No 1146 and Form No. 1146-B. Use Form No. 1146 and Form No. 1146-B. for cross-reference only.

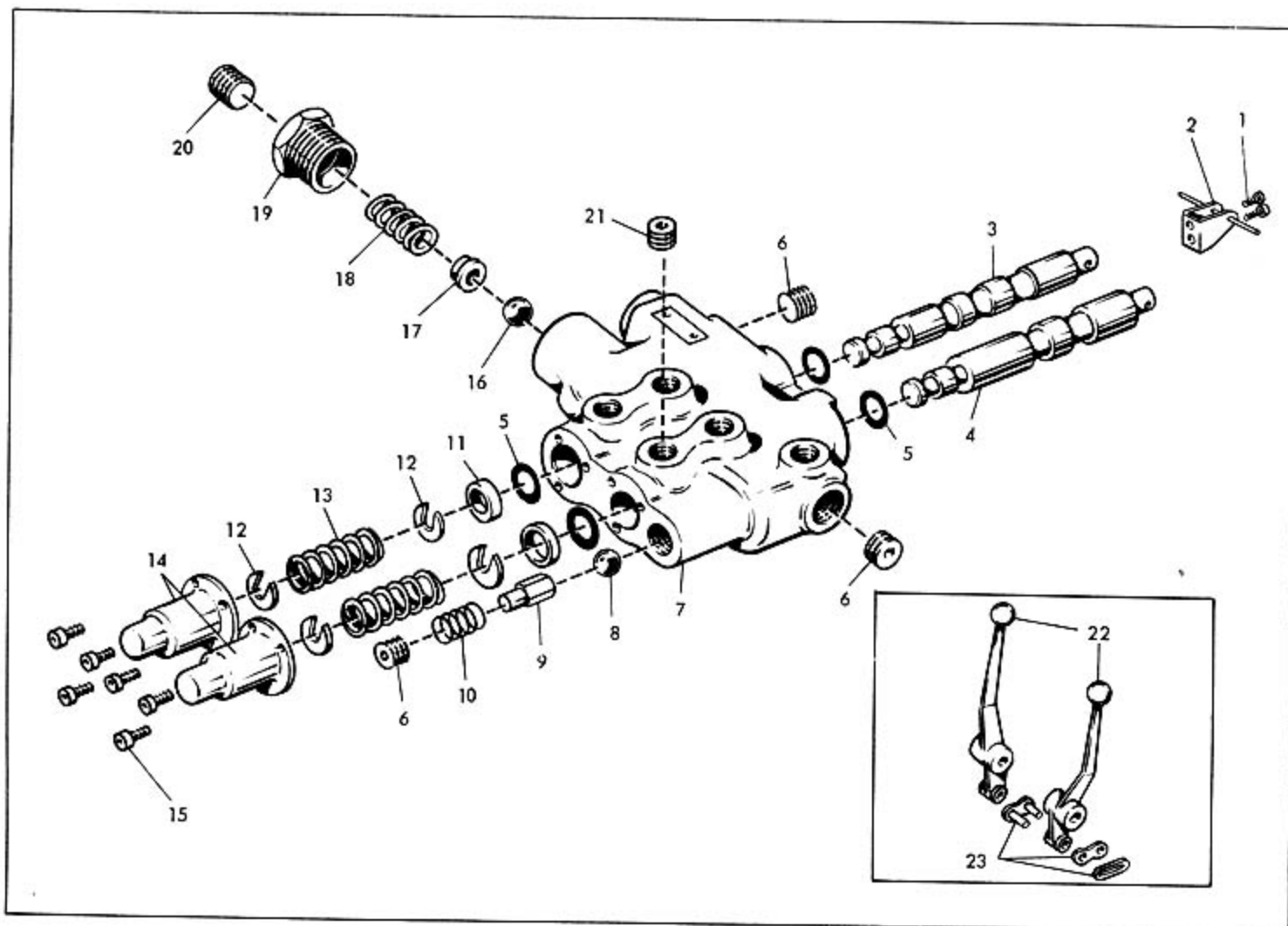

WAGNER "WONDERTROL" VALVE MODEL NO. H805-43

(With Handle Kit, Part No. L609-56, Single-Double Operation, Pressure Setting - 1700 P.S.I.)

| Item | Part No. | Description | Qty. |
|------|----------|----------------------------------------------|------|
| 1 | Z80-1852 | Socket Head Cap Screw | 2 |
| 2 | H502-1 | Handle Bracket | 1 |
| 3 | H89-15 | Spool - Double | 1 |
| 4 | H89-17 | Spool - Single | 1 |
| 5 | H62-6 | O Ring | 4 |
| 6 | Z68-1004 | Socket Head Pipe Plug | 3 |
| 7 | H51-9 | Valve Body, 1/2" Pressure Ports, 1/4" Return | 1 |
| 8 | H4-4 | Steel Ball | 1 |
| 9 | H81-1 | Check Valve Guide | 1 |
| 10 | H90-6 | Check Valve Spring | 1 |
| 11 | H23-6 | Spool Spacer | 2 |

| Item | Part No. | Description | Qty. |
|------|----------|-----------------------|------|
| 12 | H97-2 | C Washer | 4 |
| 13 | H90-5 | Spool Spring | 2 |
| 14 | H20-1 | Spool Cover | 2 |
| 15 | Z80-2009 | Socket Head Cap Screw | 6 |
| 16 | H4-2 | Steel Ball | 1 |
| 17 | H81-20 | Spring Guide | 1 |
| 18 | H90-7 | Relief Spring | 1 |
| 19 | H68-1 | Hex Bushing | 1 |
| 20 | Z68-1005 | Socket Head Pipe Plug | 1 |
| 21 | Z68-1104 | 1/2" Pipe Plug | 1 |

Valve Handle Kit, Part No. L609-56

| | | | |
|----|-------|--------|---|
| 22 | H45-7 | Handle | 2 |
|----|-------|--------|---|

| | | | |
|----|--------|---------------|---|
| 23 | L55-25 | Clip Assembly | 2 |
|----|--------|---------------|---|

NOTE: Valve Assembly Model No. H805-43, with Handle Kit No. L609-56 replaces Valve Assembly Model No. H805-10 and Handle Kit No. L609-25.

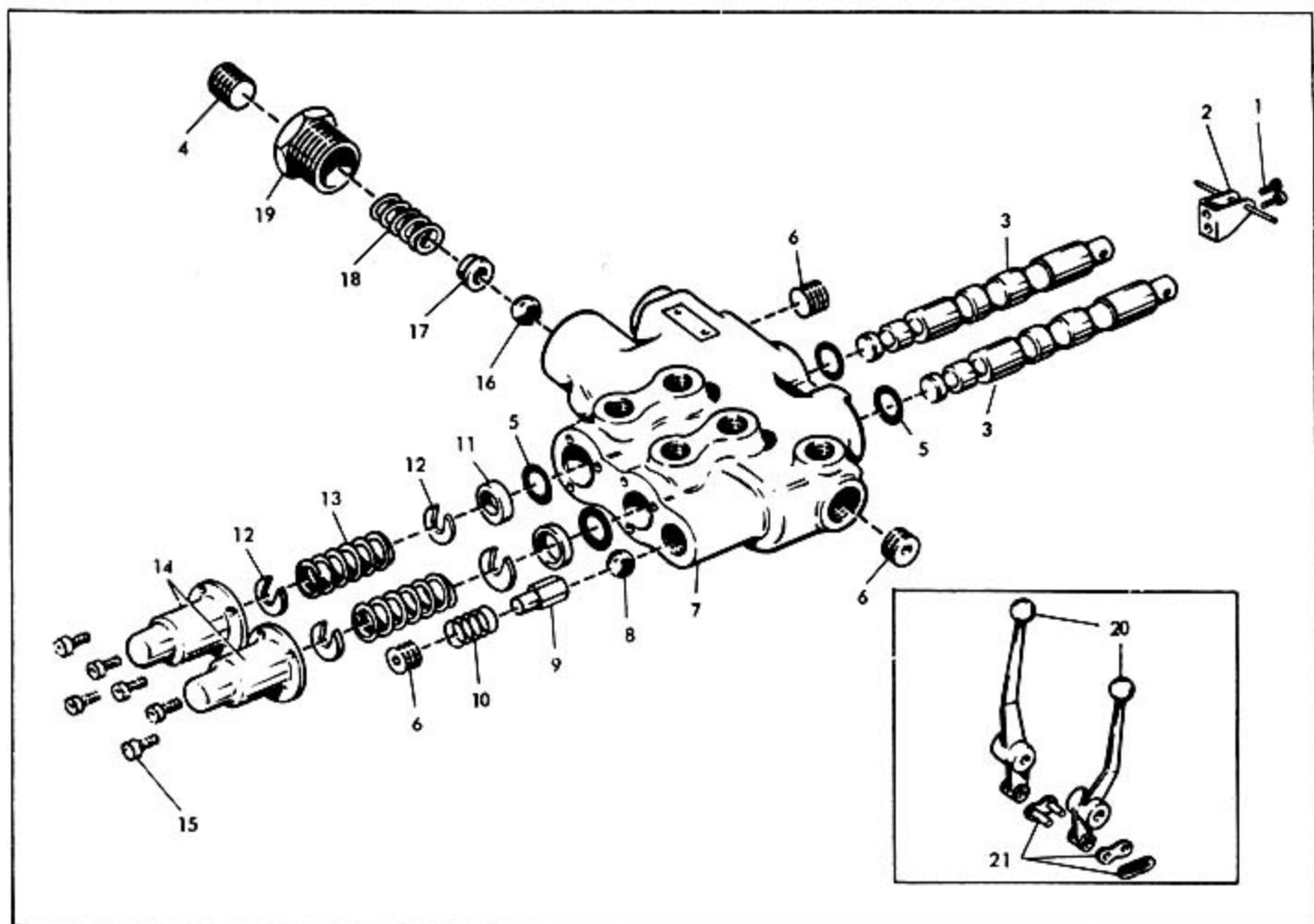

WAGNER WONDERTROL VALVE MODEL NOS. H805-42, H805-46,
H805-47, H805-58, H805-60, H805-61, H805-71, H805-72, H805-73, H805-74, H805-75

| Item | Part No. | Description | Qty. |
|------|----------|----------------------------------------------|------|
| 1 | Z80-1852 | Socket Head Cap Screw | 2 |
| 2 | H502-1 | Handle Bracket | 1 |
| 3 | H89-15 | Spool - Double | 2 |
| 4 | Z68-1005 | Socket Head Pipe Plug | 1 |
| 5 | H62-6 | O Ring | 4 |
| 6 | Z68-1004 | Socket Head Pipe Plug | 3 |
| 7 | H51-9 | Valve Body, 1/2" Pressure Ports, 3/4" Return | 1 |
| 8 | H4-4 | Steel Ball | 1 |
| 9 | H81-1 | Check Valve Guide | 1 |
| 10 | H90-6 | Check Valve Spring | 1 |

| Item | Part No. | Description | Qty. |
|------|----------|-----------------------|------|
| 11 | H23-6 | Spool Spacer | 2 |
| 12 | H97-2 | C Washer | 4 |
| 13 | H90-5 | Spool Spring | 2 |
| 14 | H20-1 | Spool Cover | 2 |
| 15 | Z80-2009 | Socket Head Cap Screw | 6 |
| 16 | H4-2 | Steel Ball | 1 |
| 17 | H81-2 | Spring Guide | 1 |
| 18 | H90-7 | Relief Spring | 1 |
| 19 | H68-1 | Hex Bushing | 1 |

Valve Handle Kit, Part No. L609-56

| | | | |
|----|-------|--------|---|
| 20 | H45-7 | Handle | 2 |
|----|-------|--------|---|

| | | | |
|----|--------|---------------|---|
| 21 | L55-25 | Clip Assembly | 2 |
|----|--------|---------------|---|

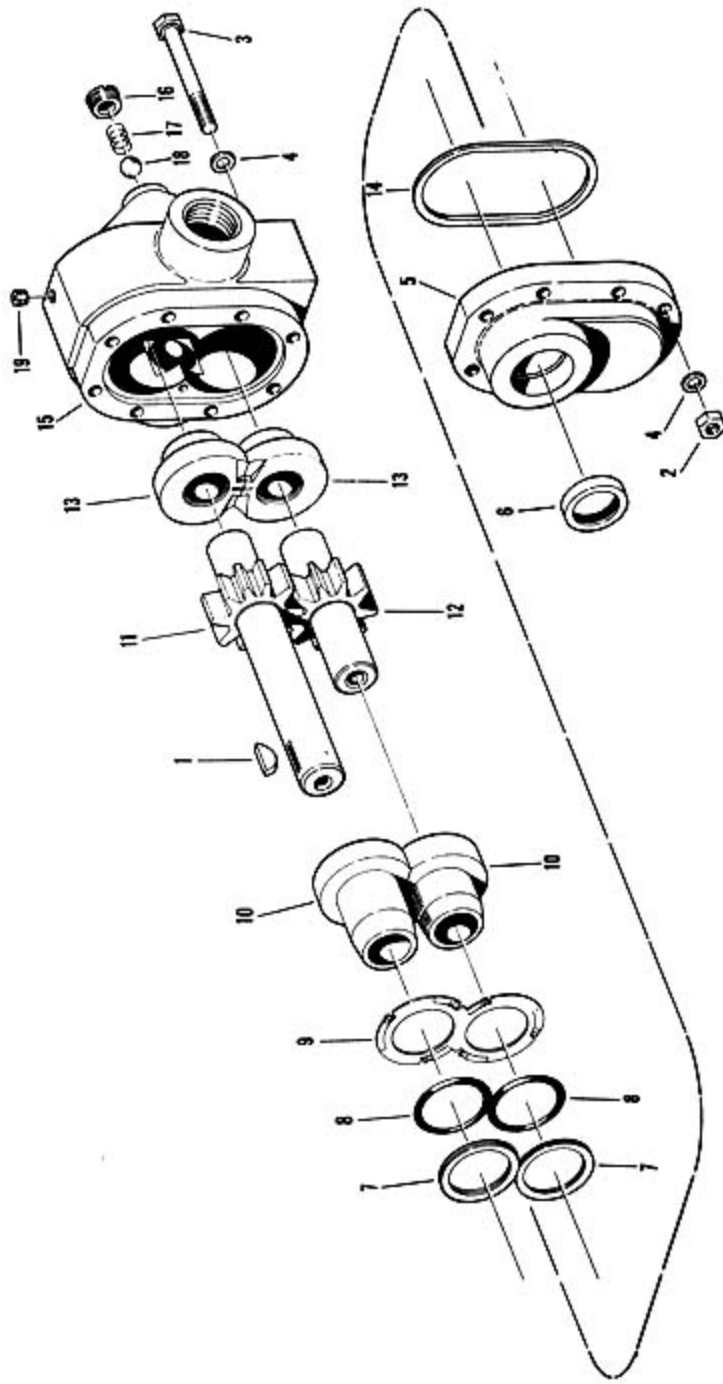

HYDRAULIC PUMP ASSEMBLY, MODEL NO. L827-10

Rated 13.2gpm min. @ 2000 rpm @ 2000 psi max.

| Item | Part No. | Description | Qty. |
|------|----------|------------------------------------------|------|
| 1 | L827-10 | Hydraulic Pump Assembly | 1 |
| 2 | Z53-10 | Woodruff Key No. 9 | 8 |
| 3 | Z61-553 | 3/8" -24 Hex Nut | 8 |
| 4 | Z80-546 | 3/8" -24 x 3 1/2" Lg. Hex Head Cap Screw | 16 |
| 5 | L97-61 | Washer | 1 |
| 6 | L24-13 | Cover | 1 |
| 7 | L62-1 | Shaft Seal | 1 |
| 8 | L62-20 | Backup Washer | 2 |
| 9 | H62-24 | Seal Ring | 2 |
| | L90-7 | Bearing Spring | 1 |

| Item | Part No. | Description | Qty. |
|------|----------|-----------------|------|
| 10 | L6-45 | Cover Bearing | 2 |
| 11 | L41-21 | Drive Gear | 1 |
| 12 | L41-22 | Driven Gear | 1 |
| 13 | L6-65 | Housing Bearing | 2 |
| 14 | L62-18 | Seal Gasket | 1 |
| 15 | L51-22 | Housing | 1 |
| 16 | L70-4 | Plug | 1 |
| 17 | L90-8 | Valve Spring | 1 |
| 18 | L4-1 | Ball | 1 |
| 19 | L70-8 | Pipe Plug | 1 |

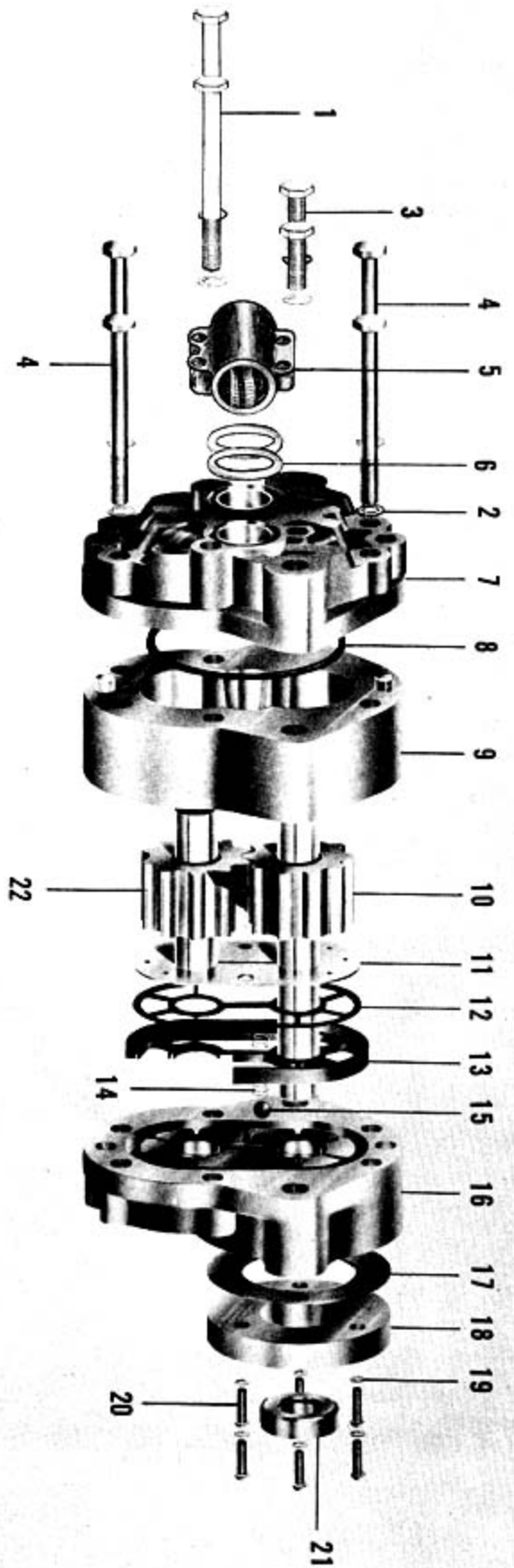

PUMP ASSEMBLY, MODEL NO. L827-12

| Item | Part No. | Description | Qty. | Item | Part No. | Description | Qty. |
|------|----------|--------------------------------------|------|------|-----------|------------------------------------|------|
| 1 | L80-82 | 5/16" Port Adapter Tie Bolts | 2 | 12 | L40-23* | Phenolic Gasket | 1 |
| 2 | Z97-23 | 5/16" Lockwashers | 8 | 13 | L62-26* | Moulded V Seal | 1 |
| 3 | L80-83 | 5/16" Port Adapter Bolts | 2 | 14 | L90-28* | Spring | 1 |
| 4 | Z80-28 | 5/16"-18 x 3" Ig. Hex Head Cap Screw | 4 | 15 | L4-10* | Ball | 1 |
| 5 | L27-3 | Port Adapter | 1 | 16 | L638-5 | Front Plate Assembly | 1 |
| 6 | L62-30* | Port Adapter O Rings | 2 | 17 | L40-22 | Seal Retainer Gasket | 1 |
| 7 | L638-4 | Back Plate Assembly | 1 | 18 | L77-30** | Seal Retainer | 1 |
| 8 | H62-25* | Back Plate O Ring | 1 | 19 | Z97-14** | No. 10 Lockwasher | 6 |
| 9 | L51-26 | Body | 1 | 20 | Z80-21 6I | No. 10-24 Round Head Machine Screw | 6 |
| 10 | L41-28 | Drive Gear Assembly | 1 | 21 | L62-27** | Shaft Seal | 1 |
| 11 | L40-21* | Diaphragm | 1 | 22 | L41-26 | Driven Gear Assembly | 1 |

* These items only available as a kit under Part No. L609-182.

** These items only available as a kit under Part No. L609-183.