

# WSM

---

## WORKSHOP MANUAL **TRACTOR**

**L3130, L3430, L3830,  
L4630, L5030**

---

# Kubota

# TO THE READER

This Workshop Manual has been prepared to provide servicing personnel with information on the mechanism, service and maintenance of KUBOTA Tractor L3130, L3430, L3830, L4630 and L5030. It is divided into two parts, "Mechanism" and "Servicing" for each section.

## ■ Mechanism

Information on the construction and function are included. This part should be understood before proceeding with troubleshooting, disassembling and servicing.

Refer to Diesel engine / Tractor Mechanism Workshop Manual (Code No. 97897-01872 / 97897-18200) for the one which has not been described to this workshop manual.

## ■ Servicing

The heading "General" includes general precautions, check and maintenance and special tools. Other section, there are troubleshooting, servicing specification lists, checking and adjusting, disassembling and assembling, and servicing which cover procedures, precautions, factory specifications and allowable limits.

All information illustrations and specifications contained in this manual are based on the latest product information available at the time of publication.

The right is reserved to make changes in all information at any time without notice.

**November 2003**

© KUBOTA Corporation 2003



## SAFETY FIRST

This symbol, the industry's "Safety Alert Symbol", is used throughout this manual and on labels on the machine itself to warn of the possibility of personal injury. Read these instructions carefully.

It is essential that you read the instructions and safety regulations before you attempt to repair or use this unit.



### DANGER

: Indicates an imminently hazardous situation which, if not avoided, will result in death or serious injury.



### WARNING

: Indicates a potentially hazardous situation which, if not avoided, could result in death or serious injury.



### CAUTION

: Indicates a potentially hazardous situation which, if not avoided, may result in minor or moderate injury.



### IMPORTANT

: Indicates that equipment or property damage could result if instructions are not followed.



### NOTE

: Gives helpful information.

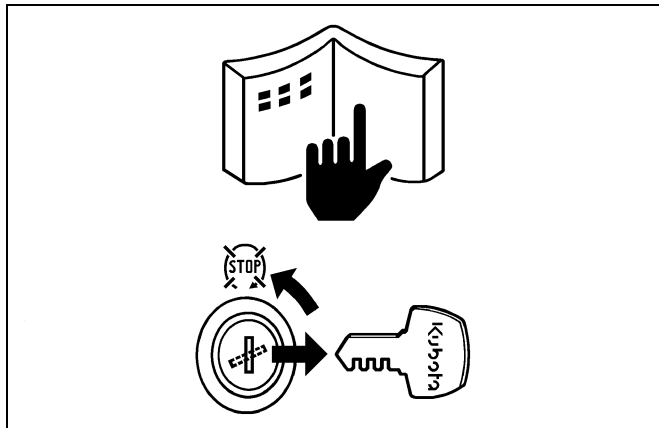

### BEFORE SERVICING AND REPAIRING

- Read all instructions and safety instructions in this manual and on your machine safety decals.
- Clean the work area and machine.
- Park the machine on a firm and level ground, and set the parking brake.
- Lower the implement to the ground.
- Stop the engine, and remove the key.
- Disconnect the battery negative cable.
- Hang a "DO NOT OPERATE" tag in operator station.

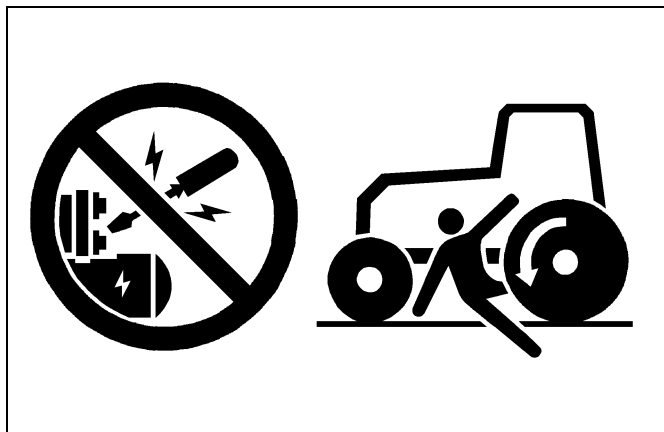

### SAFETY STARTING

- Do not start the engine by shorting across starter terminals or bypassing the safety start switch.
- Do not alter or remove any part of machine safety system.
- Before starting the engine, make sure that all shift levers are in neutral positions or in disengaged positions.
- Never start the engine while standing on ground. Start the engine only from operator's seat.

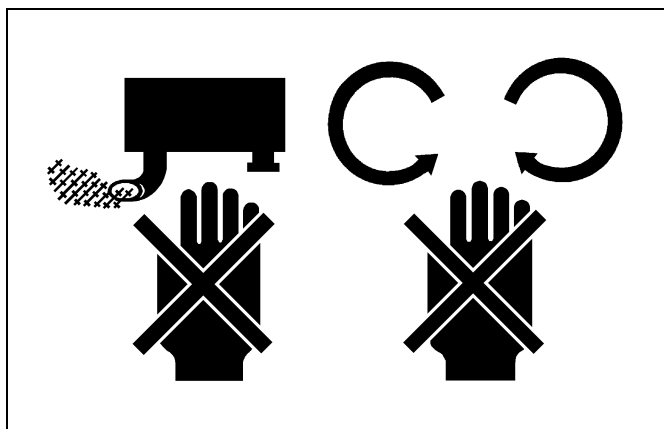

### SAFETY WORKING

- Do not work on the machine while under the influence of alcohol, medication, or other substances or while fatigued.
- Wear close fitting clothing and safety equipment appropriate to the job.
- Use tools appropriate to the work. Makeshift tools, parts, and procedures are not recommended.
- When servicing is performed together by two or more persons, take care to perform all work safely.
- Do not work under the machine that is supported solely by a jack. Always support the machine by safety stands.
- Do not touch the rotating or hot parts while the engine is running.
- Never remove the radiator cap while the engine is running, or immediately after stopping. Otherwise, hot water will spout out from radiator. Only remove radiator cap when cool enough to touch with bare hands. Slowly loosen the cap to first stop to relieve pressure before removing completely.
- Escaping fluid (fuel or hydraulic oil) under pressure can penetrate the skin causing serious injury. Relieve pressure before disconnecting hydraulic or fuel lines. Tighten all connections before applying pressure.

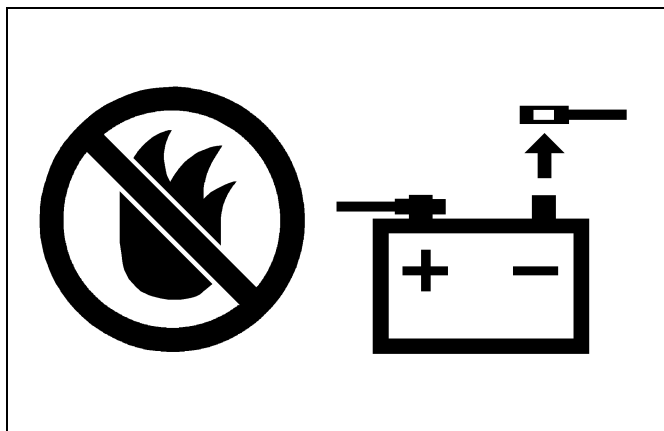
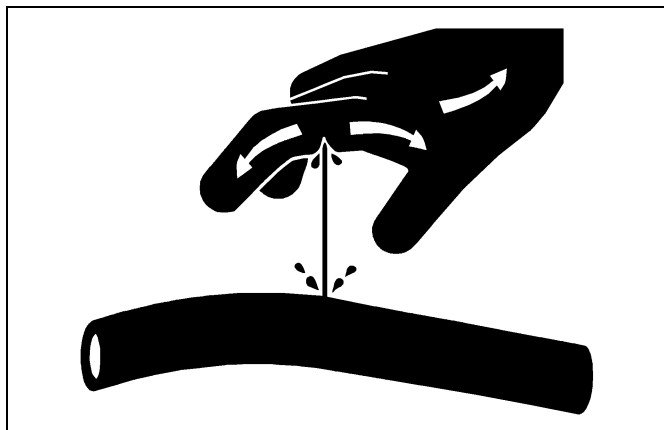

### AVOID FIRES

- Fuel is extremely flammable and explosive under certain conditions. Do not smoke or allow flames or sparks in your working area.
- To avoid sparks from an accidental short circuit, always disconnect the battery negative cable first and connect it last.
- Battery gas can explode. Keep sparks and open flame away from the top of battery, especially when charging the battery.
- Make sure that no fuel has been spilled on the engine.



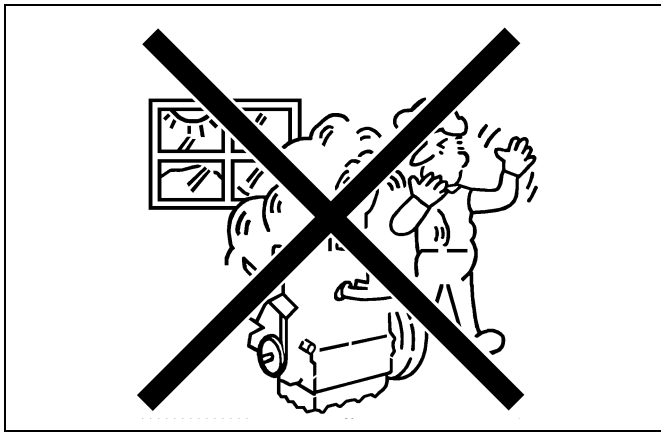

### VENTILATE WORK AREA

- If the engine must be running to do some work, make sure the area is well ventilated. Never run the engine in a closed area. The exhaust gas contains poisonous carbon monoxide.

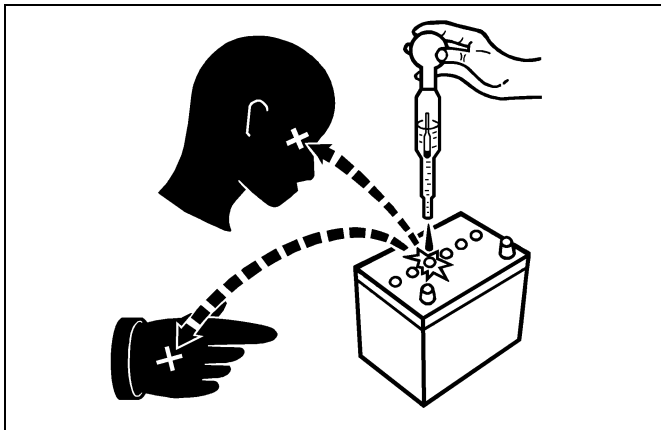

### PREVENT ACID BURNS

- Sulfuric acid in battery electrolyte is poisonous. It is strong enough to burn skin, clothing and cause blindness if splashed into eyes. Keep electrolyte away from eyes, hands and clothing. If you spill electrolyte on yourself, flush with water, and get medical attention immediately.

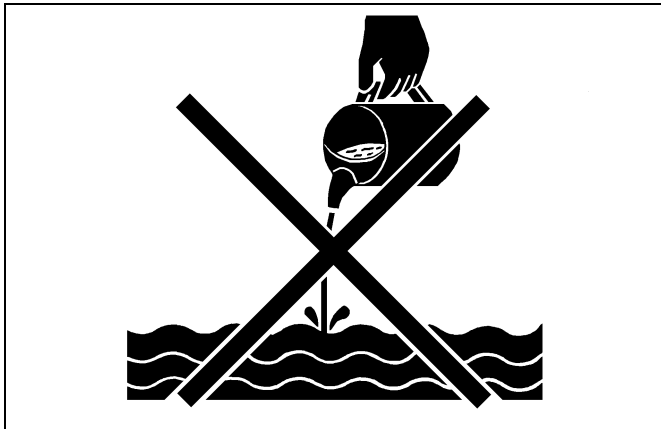

### DISPOSE OF FLUIDS PROPERLY

- Do not pour fluids into the ground, down a drain, or into a stream, pond, or lake. Observe relevant environmental protection regulations when disposing of oil, fuel, coolant, electrolyte and other harmful waste.

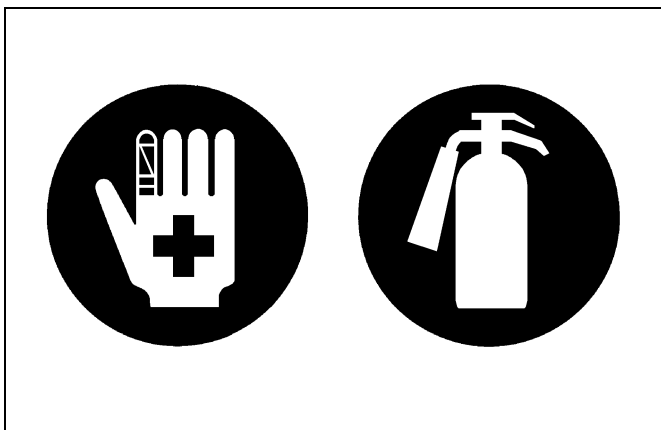

### PREPARE FOR EMERGENCIES

- Keep a first aid kit and fire extinguisher handy at all times.
- Keep emergency numbers for doctors, ambulance service, hospital and fire department near your telephone.

## SAFETY DECALS

The following safety decals are installed on the machine.

If a decal becomes damaged, illegible or is not on the machine, replace it. The decal part number is listed in the parts list.

(1) Part No. TA040-4965-2

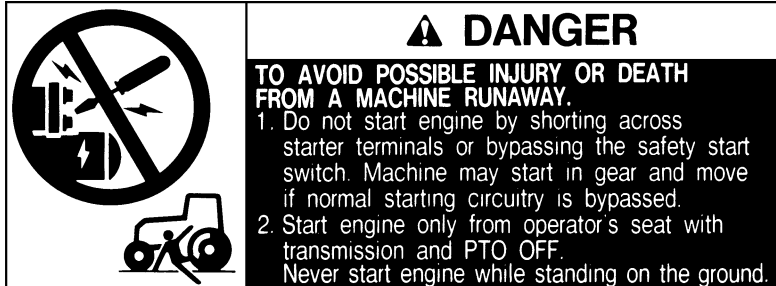

(4) Part No. TA040-4956-2  
Diesel fuel only. No fire

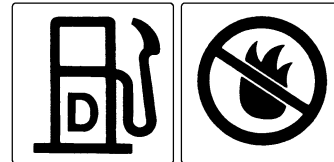

(2) Part No. TD054-9848-1 [Rear mount type ROPS]

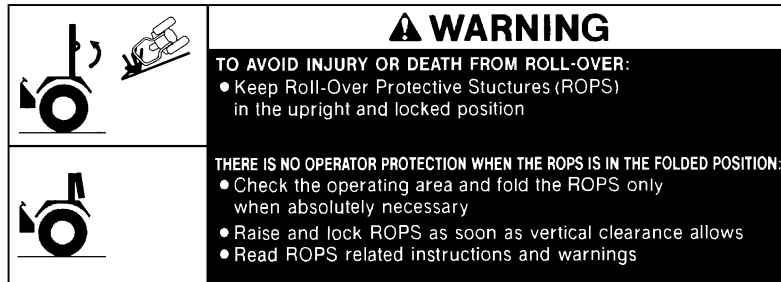

(5) Part No. TA040-4935-1



1AGAMBQAP062A

(3) Part No. TA040-4959-3

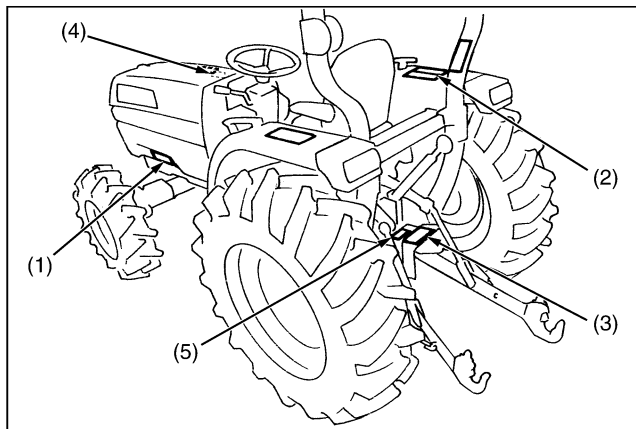
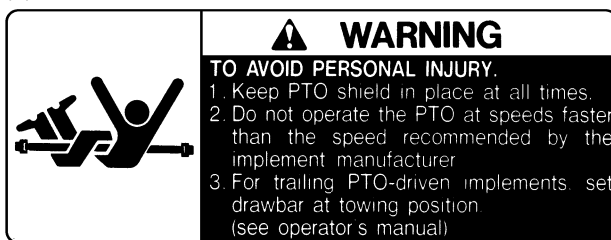

3TLABABCP005A

(1) Part No. TA140-4992-1 [GST Type]

	<p><b>⚠ WARNING</b> BEFORE DISMOUNTING TRACTOR:</p> <p><b>1. ALWAYS SET PARKING BRAKE.</b> Leaving transmission in gear with the engine stopped will not prevent tractor from rolling.</p> <p><b>2. PARK ON LEVEL GROUND WHENEVER POSSIBLE.</b> If parking on a slope, position tractor across the slope.</p> <p><b>3. LOWER ALL IMPLEMENTS TO THE GROUND.</b> Failure to comply to this warning may allow the wheels to slip, and could cause injury or death.</p> <p><b>4. LOCK SHUTTLE SHIFT LEVER IN NEUTRAL POSITION AND STOP THE ENGINE.</b></p>
---	--

(2) Part No. 6C140-4746-1

<p><b>⚠ WARNING</b></p> <p><b>TO AVOID PERSONAL INJURY:</b> Do not modify or repair a ROPS because welding, grinding, drilling or cutting any portion may weaken the structure.</p>
---

(1) Part No. TA140-4933-1 [Manual Transmission Type]

	<p><b>⚠ WARNING</b> BEFORE DISMOUNTING TRACTOR:</p> <p><b>1. ALWAYS SET PARKING BRAKE.</b> Leaving transmission in gear with the engine stopped will not prevent tractor from rolling.</p> <p><b>2. PARK ON LEVEL GROUND WHENEVER POSSIBLE.</b> If parking on a slope, position tractor across the slope.</p> <p><b>3. LOWER ALL IMPLEMENTS TO THE GROUND.</b> Failure to comply to this warning may allow the wheels to slip, and could cause injury or death.</p> <p><b>4. LOCK SHUTTLE SHIFT LEVER IN NEUTRAL POSITION AND STOP THE ENGINE.</b></p>
---	--

(1) Part No. TA240-4933-2 [HST Type]

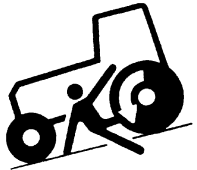
	<p><b>⚠ WARNING</b> BEFORE DISMOUNTING TRACTOR:</p> <p><b>1. ALWAYS SET PARKING BRAKE.</b> Leaving transmission in gear with the engine stopped will not prevent tractor from rolling.</p> <p><b>2. PARK ON LEVEL GROUND WHENEVER POSSIBLE.</b> If parking on a slope, position tractor across the slope.</p> <p><b>3. LOWER ALL IMPLEMENTS TO THE GROUND.</b> Failure to comply to this warning may allow the wheels to slip, and could cause injury or death.</p> <p><b>4. STOP THE ENGINE.</b></p>
--	---

[CABIN Type]

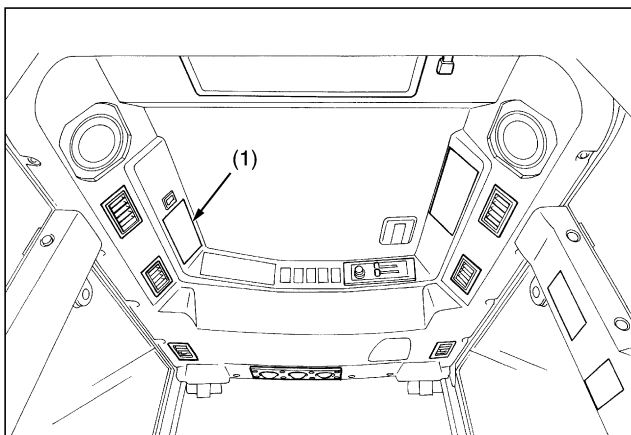

[ROPS Type]

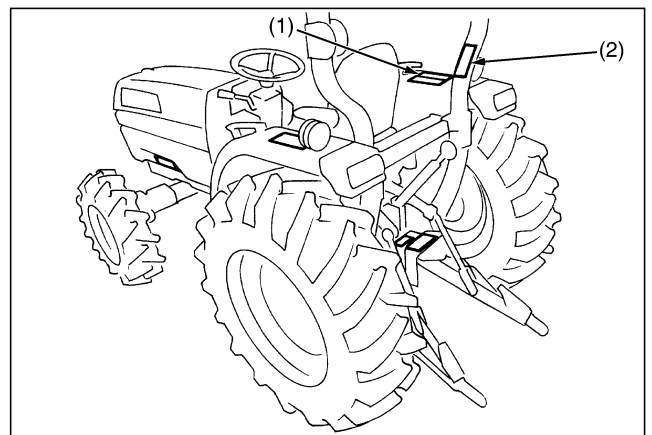

3TLABABCP006A

(1) Part No. 35260-3491-4

**CAUTION**

**TO AVOID PERSONAL INJURY:**

1. Read and understand the operator's manual before operation.
2. Before starting the engine, make sure that everyone is at a safe distance from the tractor and that the PTO is OFF.
3. Do not allow passengers on the tractor at any time.
4. Before allowing other people to use the tractor, have them read the operator's manual.
5. Check the tightness of all nuts and bolts regularly.
6. Keep all shields in place and stay away from all moving parts.
7. Lock the two brake pedals together before driving on the road.
8. Slow down for turns, or rough roads, or when applying individual brakes.
9. On public roads use SMV emblem and hazard lights, if required by local traffic and safety regulations.
10. Pull only from the drawbar.
11. Before dismounting, lower the implement to the ground, set the parking brake, stop the engine and remove the key.
12. Securely support tractor and implements before working underneath.

(2) Part No. TD060-3012-1

 <b>RECYCLE</b>	 <b>FLAMMABLES</b>	 <b>SHIELD EYES</b>	 <b>KEEP OUT OF THE REACH OF CHILDREN</b>	 <b>CAUTIONS OF SULFURIC ACID</b>	 <b>READ INSTRUCTION MANUAL CAREFULLY</b>	 <b>EXPLOSIVE</b>	<b>HYDROMETER</b>  OK CHARGE BATTERY BATTERY DK 80660
<b>NX110-5MF</b> 12V AMP HR (20HR) 55 RESERVE CAPACITY (MIN) 133 COLD CRANKING AMPS (-18°C) 582	- DUE TO HYDROGEN GAS GENERATED FROM BATTERY, HANDLING WITHOUT CARE CAN CAUSE FIRE AND EXPLOSION - THIS BATTERY IS ONLY FOR STARTING ENGINE. DO NOT APPLY THIS PRODUCT FOR OTHER USES. A - CHARGE THIS BATTERY ONLY AT WELL VENTILATED PLACES, AND AVOID SHORTS OR SPARKS. D - REFER TO THE INSTRUCTION MANUAL OF VEHICLE OR BATTERY BEFORE USING BOOSTER CABLE. S - SULFURIC ACID MAY CAUSE BLINDNESS OR SEVERE BURN. IN CASE EYES, SKIN, CLOTHES OR ANY ARTICLES ARE STAINED WITH ACID, FLUSH OBJECTS IMMEDIATELY WITH WATER IF ACID BEING SWALLOWED, DRINK PLENTY OF WATER PROMPTLY. IN CASE OF ACCIDENTAL CONTACT, CONSULT A DOCTOR IMMEDIATELY. R - BATTERY FILLED WITH ACID (DO NOT TILT OR SPILL) - FLAMMABLE. DO NOT CHARGE NEAR FIRE OR SPARKS - DO NOT CHARGE RAPIDLY - DO NOT DISASSEMBLE THE BATTERY (SEALED TYPE).						<b>80D26R</b> FITTING DATE: 0 1 2 3 4 5 6 7 8 9 YEAR 1 2 3 4 5 6 7 8 9 10 11 12 MONTH
<b>DANGER EXPLOSIVE GASES</b> Cigarettes, flames or sparks could cause battery to explode. Always shield eyes and face from battery. Do not charge or use booster cables or adjust post connections without proper instruction and training.	<b>POISON CAUSES SEVERE BURNS</b> Contains sulfuric acid. Avoid contact with skin, eyes or clothing. In event of accident flush with water and call a physician immediately. <b>KEEP OUT OF REACH OF CHILDREN</b>						

(3) Part No. 32751-4958-1  
 Stay clear of engine fan and fan belt.



(4) Part No. TC030-4958-1  
 Do not touch hot surface like muffler etc.



[CABIN Type]

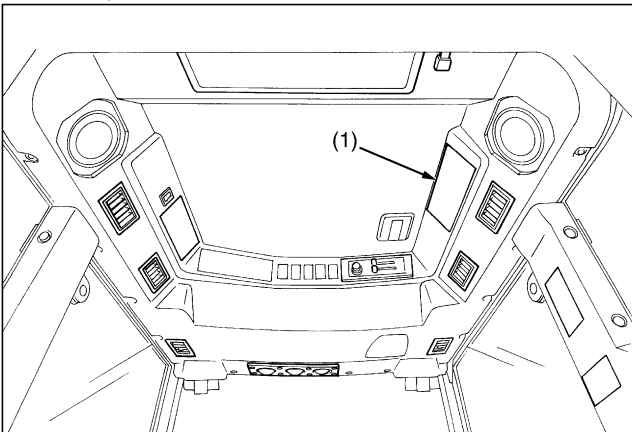

[ROPS Type]

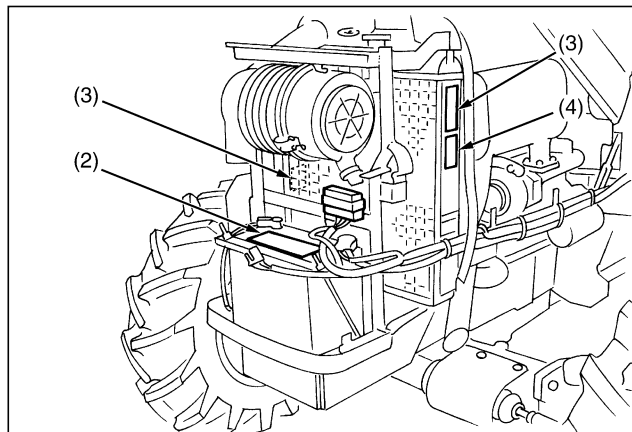
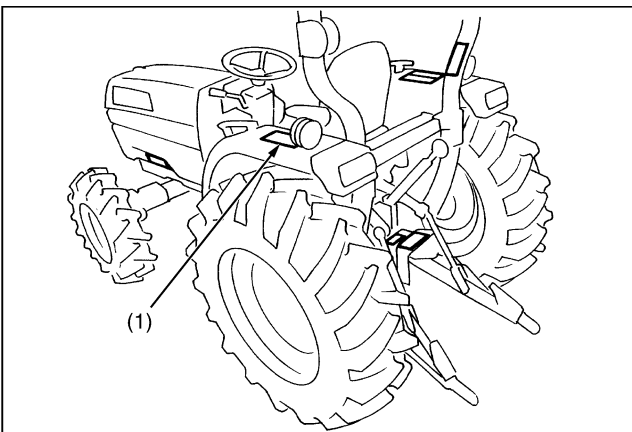

3TLABBCP008A

(1) Part No. TA046-4932-1 [Mid mount type ROPS]

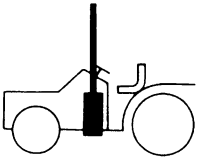
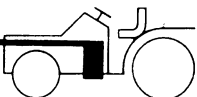
	<p><b>⚠ WARNING</b></p> <p><b>TO AVOID INJURY OR DEATH FROM ROLL-OVER</b></p> <ul style="list-style-type: none"> <li>• Keep roll-over protective structure (ROPS) in raised position.</li> <li>• Check operating environment for vertical clearance for ROPS.</li> </ul>
	 <ul style="list-style-type: none"> <li>• In folded position, ROPS protection is eliminated.</li> <li>• Raise ROPS if vertical clearance allows, and read related instructions and warnings.</li> </ul>

1AGAOAJAP062A

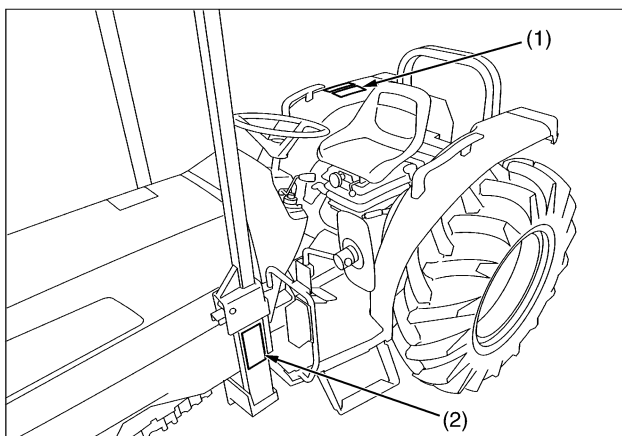

(2) Part No. TA046-4928-2 [Mid mount type ROPS]

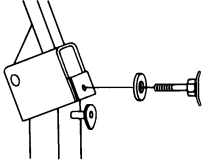
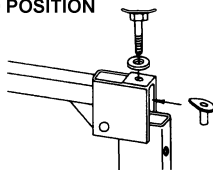
<p><b>IMPORTANT</b></p> <p><b>RAISED POSITION</b></p>  <p>Put spacer in hole and tighten bolt.</p>
<p><b>FOLDED POSITION</b></p>  <p>Put spacer and tighten bolt</p>
<p><b>⚠ CAUTION</b></p> <p><b>TO AVOID INJURY WHEN RAISING OR LOWERING ROPS</b></p> <ul style="list-style-type: none"> <li>• Stop and park the tractor.</li> <li>• Hold center of ROPS by hand when lowering ROPS not to free-fall.</li> <li>• Make sure bolts and spacers are installed correctly.</li> </ul>

1AGAMBQAP058A

**CARE OF DANGER, WARNING AND CAUTION LABELS**

1. Keep danger, warning and caution labels clean and free from obstructing material.
2. Clean danger, warning and caution labels with soap and water, dry with a soft cloth.
3. Replace damaged or missing danger, warning and caution labels with new labels.
4. If a component with danger, warning or caution label (s) affixed is replaced with new part, make sure new label (s) is (are) attached in the same location (s) as the replaced component.
5. Mount new danger, warning and caution labels by applying on a clean dry surface and pressing any bubbles to outside edge.

3TLABABCP007A

# SPECIFICATIONS

## ROPS Type

Model		L3130	L3430	
		Manual Transmission		
Engine	Model	D1503-MA-E-GST-EU	D1703-MA-E-GST-EU	
	Type	Indirect injection vertical, water-cooled, 4-cycle diesel		
	Number of cylinders	3		
	Total displacement	1.499 L (91.5 cu.in.)	1.647 L (100.5 cu.in.)	
	Bore and stroke	83 × 92.4 mm (3.3 × 3.6 in.)	87 × 92.4 mm (3.4 × 3.6 in.)	
	Net power	23.1 kW (31.0 HP)*	25.1 kW (33.6 HP)*	
	PTO power (factory observe)	19.0 kW (25.8 HP)* / 2700 min <sup>-1</sup> (rpm)	21.3 kW (29.0 HP)* / 2700 min <sup>-1</sup> (rpm)	
	Maximum torque	102.9 N·m (10.5 kgf·m, 75.9 ft-lbs)	108.3 N·m (11.05 kgf·m, 79.9 ft-lbs)	
	Battery capacity	12 V, RC : 123 min, CCA : 490 A		
	Fuel	Diesel fuel No. 1 [below -10 °C (14 °F)], Diesel fuel No. 2-D [above -10 °C (14 °F)]		
Capacities	Fuel tank	40 L (10.6 U.S.gals, 8.8 Imp.gals)		
	Engine crankcase (with filter)	5.7 L (6.0 U.S.qts, 5.0 Imp.qts)		
	Engine coolant	6.0 L (6.3 U.S.qts, 5.3 Imp.qts)		
	Transmission case	42 L (11.1 U.S.gals, 9.2 Imp.gals)		
Dimensions	Overall length (without 3P)	3025 mm (119.1 in.)	3015 mm (118.7 in.)	
	Overall width (min. tread)	1430 mm (56.3 in.)		
	Overall height (with ROPS)	2255 mm (88.8 in.)	2415 mm (95.1 in.)	
	Wheel base	1805 mm (71.1 in.)		
	Min. ground clearance	370 mm (14.6 in.)		
	Tread	Front	1150 mm (45.3 in.)	
	Rear	1110 mm (43.7 in.), 1205 mm (47.4 in.), 1300 mm (51.2 in.), 1385 mm (54.5 in.)		
Weight (with ROPS)		1480 kg (3265 lbs)	1460 kg (3220 lbs)	
Travelling system	Standard tire size	Front	7-16	
		Rear	12.4-24	
	Clutch	Dry type single stage		
	Steering	Hydrostatic power steering		
	Transmission	F8, R8 fully synchronized main and shuttle transmission (with creep speed model : F16, R16 fully synchronized main and shuttle transmission)		
	Braking system	Wet disk type		
Min. turning radius (with brake)	2.7 m (8.9 feet)			
Hydraulic system	Hydraulic control system	Position control		
	Pump capacity	31.5 L (8.3 U.S.gals, 6.9 Imp.gals) / min.		
	Three point hitch	SAE Category 1		
	Max. lift force	At lift points	1700 kg (3750 lbs)	
		24 in. behind lift points	1200 kg (2650 lbs)	
System pressure	17.7 MPa (180 kgf/cm <sup>2</sup> , 2560 psi)			
PTO	Rear PTO	SAE 1-3/8, 6 splines		
	PTO / Engine speed	540 min <sup>-1</sup> (rpm) / 2550 min <sup>-1</sup> (rpm), 750 min <sup>-1</sup> (rpm) / 2250 min <sup>-1</sup> (rpm)		

Note : \* Manufacture's estimate

The company reserves the right to change the specifications without notice.

W10281170

## ROPS Type

Model		L3830		L4630	
		Manual Transmission			
Engine	Model	D1803-MA-E-GST-EU		V2203-MA-E-GST-EU	
	Type	Indirect injection vertical, water-cooled, 4-cycle diesel			
	Number of cylinders	3		4	
	Total displacement	1.826 L (111.4 cu.in.)		2.197 L (134.1 cu.in.)	
	Bore and stroke	87 × 102.4 mm (3.4 × 4.0 in.)		87 × 92.4 mm (3.4 × 3.6 in.)	
	Net power	27.9 kW (37.4 HP)*		33.3 kW (44.7 HP)*	
	PTO power (factory observe)	23.9 kW (32.5 HP)* / 2700 min <sup>-1</sup> (rpm)		29.5 kW (40.1 HP)* / 2700 min <sup>-1</sup> (rpm)	
	Maximum torque	120.7 N·m (12.3 kgf·m, 89.0 ft·lbs)		146.2 N·m (14.9 kgf·m, 107.8 ft·lbs)	
	Battery capacity	12 V, RC : 133 min, CCA : 582 A			
	Fuel	Diesel fuel No. 1 [below -10 °C (14 °F)], Diesel fuel No. 2-D [above -10 °C (14 °F)]			
Capacities	Fuel tank	40 L (10.6 U.S.gals, 8.8 Imp.gals)			
	Engine crankcase (with filter)	6.7 L (7.1 U.S.qts, 5.9 Imp.qts)		8.2 L (8.7 U.S.qts, 7.2 Imp.qts)	
	Engine coolant	7.5 L (7.9 U.S.qts, 6.6 Imp.qts)			
	Transmission case	43 L (11.4 U.S.gals, 9.5 Imp.gals)			
Dimensions	Overall length (without 3P)	3075 mm (121.1 in.)		3170 mm (124.8 in.)	
	Overall width (min. tread)	1485 mm (58.5 in.)			
	Overall height (with ROPS)	2420 mm (95.3 in.)			
	Wheel base	1840 mm (72.4 in.)		1895 mm (74.6 in.)	
	Min. ground clearance	400 mm (15.7 in.)			
	Tread	Front	1145 mm (45.1 in.)		
Rear		1140 mm (44.9 in.), 1210 mm (47.6 in.), 1310 mm (51.6 in.), 1410 mm (55.5 in.)			
Weight (with ROPS)		1500 kg (3305 lbs)		1520 kg (3351 lbs)	
Travelling system	Standard tire size	Front	8-16		
		Rear	13.6-24		
	Clutch	Dry type single stage			
	Steering	Hydrostatic power steering			
	Transmission	F8, R8 fully synchronized main and shuttle transmission (with creep speed model : F16, R16 fully synchronized main and shuttle transmission)			
	Braking system	Wet disk type			
Min. turning radius (with brake)	2.7 m (8.9 feet)				
Hydraulic system	Hydraulic control system	Position control			
	Pump capacity	31.5 L (8.3 U.S.gals, 6.9 Imp.gals) / min.		37.0 L (9.8 U.S.gals, 8.1 Imp.gals) / min.	
	Three point hitch	SAE Category 1			
	Max. lift force	At lift points	1750 kg (3860 lbs)		
		24 in. behind lift points	1250 kg (2760 lbs)		
System pressure	17.7 MPa (180 kgf/cm <sup>2</sup> , 2560 psi)				
PTO	Rear PTO	SAE 1-3/8, 6 splines			
	PTO / Engine speed	540 min <sup>-1</sup> (rpm) / 2550 min <sup>-1</sup> (rpm), 750 min <sup>-1</sup> (rpm) / 2250 min <sup>-1</sup> (rpm)			

Note : \* Manufacturer's estimate

The company reserves the right to change the specifications without notice.

W10359440



**CABIN Type**

Model		L3830	L4630	
		Manual Transmission		GST
Engine	Model	D1803-MA-E-GST-EU	V2203-MA-E-GST-EU	
	Type	Indirect injection vertical, water-cooled, 4-cycle diesel		
	Number of cylinders	3	4	
	Total displacement	1.826 L (111.4 cu.in.)	2.197 L (134.1 cu.in.)	
	Bore and stroke	87 × 102.4 mm (3.4 × 4.0 in.)	87 × 92.4 mm (3.4 × 3.6 in.)	
	Net power	27.9 kW (37.9 HP)*	33.3 kW (45.3 HP)*	
	PTO power (factory observe)	23.9 kW (32.5 HP)* / 2700 min <sup>-1</sup> (rpm)	29.5 kW (40.1 HP)* / 2700 min <sup>-1</sup> (rpm)	
	Maximum torque	120.7 N-m (12.3 kgf-m, 89.0 ft-lbs)	146.2 N-m (14.9 kgf-m, 107.8 ft-lbs)	
	Battery capacity	12 V, RC : 133 min, CCA : 582 A		
	Fuel	Diesel fuel No. 1 [below -10 °C (14 °F)], Diesel fuel No. 2 [above -10 °C (14 °F)]		
Capacities	Fuel tank	40 L (10.6 U.S.gals, 8.8 Imp.gals)		
	Engine crankcase (with filter)	6.7 L (7.1 U.S.qts, 5.9 Imp.qts)	8.2 L (8.7 U.S.qts, 7.2 Imp.qts)	
	Engine coolant	8.7 L (9.2 U.S.qts, 7.7 Imp.qts)		
	Transmission case	43 L (11.4 U.S.gals, 9.5 Imp.gals)		
Dimensions	Overall length (without 3P)	3075 mm (121.1 in.)	3170 mm (124.8 in.)	
	Overall width (min. tread)	1485 mm (58.5 in.)		
	Overall height	2195 mm (86.4 in.)		
	Wheel base	1840 mm (72.4 in.)	1895 mm (74.6 in.)	
	Min. ground clearance	400 mm (15.7 in.)		
	Tread	Front	1145 mm (45.1 in.)	
Rear		1140 mm (44.9 in.), 1210 mm (47.6 in.), 1310 mm (51.6 in.), 1410 mm (55.5 in.)		
Weight		1640 kg (3616 lbs)	1690 kg (3726 lbs)	
Travelling system	Standard tire size	Front	8-16	
		Rear	13.6-24	
	Clutch	Dry type single stage		
	Steering	Hydrostatic power steering		
	Transmission	16 forward and 16 reverse speeds	24 forward and 16 reverse speeds	
	Braking system	Wet disk type		
	Min. turning radius (with brake)	2.7 m (8.9 feet)		
Hydraulic system	Hydraulic control system	Position control		
	Pump capacity	31.5 L (8.3 U.S.gals, 6.9 Imp.gals) / min.	37.0 L (9.8 U.S.gals, 8.1 Imp.gals) / min.	
	Three point hitch	SAE Category 1		
	Max. lift force	At lift points	1750 kg (3860 lbs)	
		24 in. behind lift points	1250 kg (2760 lbs)	
System pressure	17.7 MPa (180 kgf/cm <sup>2</sup> , 2560 psi)			
PTO	Rear PTO	SAE 1-3/8, 6 splines		
	PTO / Engine speed	540 min <sup>-1</sup> (rpm) / 2550 min <sup>-1</sup> (rpm), 750 min <sup>-1</sup> (rpm) / 2250 min <sup>-1</sup> (rpm)	540 min <sup>-1</sup> (rpm) / 2550 min <sup>-1</sup> (rpm)	

Note : \* Manufacture's estimate

The company reserves the right to change the specifications without notice.

W10390020



**CABIN Type**

Model		L5030		
		Manual Transmission	GST	HST
Engine	Model	V2403-MA-E-GST-EU		
	Type	Indirect injection vertical, water-cooled, 4-cycle diesel		
	Number of cylinders	4		
	Total displacement	2.434 L (148.5 cu.in.)		
	Bore and stroke	87 × 102.4 mm (3.4 × 4.0 in.)		
	Net power	37.3 kW (50.7 HP)*		
	PTO power (factory observe)	32.8 kW (44.6 HP)* / 2700 min <sup>-1</sup> (rpm)		31.7 kW (43.1 HP)* / 2700 min <sup>-1</sup> (rpm)
	Maximum torque	162.4 N·m (16.6 kgf·m, 119.8 ft-lbs)		
	Battery capacity	12 V, RC : 133 min, CCA : 582 A		
	Fuel	Diesel fuel No. 1 [below -10 °C (14 °F)], Diesel fuel No. 2 [above -10 °C (14 °F)]		
Capacities	Fuel tank	43 L (11.4 U.S.gals, 9.5 Imp.gals)		
	Engine crankcase (with filter)	8.2 L (8.7 U.S.qts, 7.2 Imp.qts)		
	Engine coolant	9.2 L (9.7 U.S.qts, 8.1 Imp.qts)		
	Transmission case	45 L (11.9 U.S.gals, 9.9 Imp.gals)		
Dimensions	Overall length (without 3P)	3245 mm (127.8 in.)		
	Overall width (min. tread)	1470 mm (57.9 in.)		
	Overall height	2275 mm (89.6 in.)		
	Wheel base	1915 mm (75.4 in.)		
	Min. ground clearance	425 mm (16.7 in.)		
	Tread	Front	1135 mm (44.7 in.)	
	Rear	1125 mm (44.3 in.), 1225 mm (48.2 in.), 1325 mm (52.2 in.)		
Weight		1840 kg (4057 lbs)	1860 kg (4101 lbs)	
Travelling system	Standard tire size	Front	9.5-16	
		Rear	13.6-28	
	Clutch	Dry type single stage		
	Steering	Hydrostatic power steering		
	Transmission	16 forward and 16 reverse speeds	24 forward and 16 reverse speeds	3 speeds
	Braking system	Wet disk type		
	Min. turning radius (with brake)	3.2 m (10.5 feet)		
Hydraulic system	Hydraulic control system	Position control		
	Pump capacity	37.0 L (9.8 U.S.gals, 8.1 Imp.gals) / min.		
	Three point hitch	SAE Category 1		
	Max. lift force	At lift points	1750 kg (3860 lbs)	
		24 in. behind lift points	1350 kg (2976 lbs)	
System pressure	17.7 MPa (180 kgf/cm <sup>2</sup> , 2560 psi)			
PTO	Rear PTO	SAE 1-3/8, 6 splines		
	PTO / Engine speed	540 min <sup>-1</sup> (rpm) / 2550 min <sup>-1</sup> (rpm)		540 min <sup>-1</sup> (rpm) / 2660 min <sup>-1</sup> (rpm)

Note : \* Manufacture's estimate

The company reserves the right to change the specifications without notice.

W10399600

# TRAVELLING SPEEDS

## [Manual Transmission Type]

Model			L3130	L3830 - L4630
Tire size (Rear)			12.4-24	13.6-24
Shuttle shift lever	Range gear shift lever	Main gear shift lever	km/h (mph)	km/h (mph)
Forward (At rated engine rpm)	Low	1	1.81 (1.1)	1.68 (1.0)
		2	2.56 (1.6)	2.38 (1.5)
		3	4.16 (2.6)	3.86 (2.4)
		4	6.14 (3.8)	5.71 (3.5)
	High	1	9.13 (5.7)	8.49 (5.3)
		2	12.91 (8.0)	12.01 (7.5)
		3	20.96 (13.0)	19.49 (12.1)
		4	30.96 (19.2)	28.78 (17.9)
Reverse (At rated engine rpm)	Low	1	1.51 (0.9)	1.40 (0.9)
		2	2.13 (1.3)	1.98 (1.2)
		3	3.46 (2.1)	3.22 (2.0)
		4	5.11 (3.2)	4.76 (3.0)
	High	1	7.61 (4.7)	7.07 (4.4)
		2	10.76 (6.7)	10.01 (6.2)
		3	17.47 (10.9)	16.24 (10.1)
		4	25.80 (16.0)	23.99 (14.9)

The company reserves the right to change the specifications without notice.

W1035065

**[With Creep Speed Model]**

Model			L3130		L3830 - L4630		L5030	
Creep gear shift lever			High	Low	High	Low	High	Low
Tire size (Rear)			12.4-24		13.6-24		13.6-28	
Shuttle shift lever	Range gear shift lever	Main gear shift lever	km/h (mph)	km/h (mph)	km/h (mph)	km/h (mph)	km/h (mph)	km/h (mph)
Forward (At rated engine rpm)	Low	1	1.81 (1.1)	0.20 (0.1)	1.68 (1.0)	0.19 (0.1)	1.77 (1.1)	0.20 (0.1)
		2	2.56 (1.6)	0.29 (0.2)	2.38 (1.5)	0.27 (0.2)	2.51 (1.6)	0.28 (0.2)
		3	4.16 (2.6)	0.47 (0.3)	3.86 (2.4)	0.43 (0.3)	4.07 (2.5)	0.46 (0.3)
		4	6.14 (3.8)	0.69 (0.4)	5.71 (3.5)	0.64 (0.4)	6.02 (3.7)	0.68 (0.4)
	High	1	9.13 (5.7)	1.02 (0.6)	8.49 (5.3)	0.95 (0.6)	8.95 (5.6)	1.00 (0.6)
		2	12.91 (8.0)	1.45 (0.9)	12.01 (7.5)	1.35 (0.8)	12.66 (7.9)	1.42 (0.9)
		3	20.96 (13.0)	2.35 (1.5)	19.49 (12.1)	2.19 (1.4)	20.54 (12.8)	2.31 (1.4)
		4	30.96 (19.2)	3.48 (2.2)	28.78 (17.9)	3.23 (2.0)	30.34 (18.9)	3.41 (2.1)
Reverse (At rated engine rpm)	Low	1	1.51 (0.9)	0.17 (0.1)	1.40 (0.9)	0.16 (0.1)	1.48 (0.9)	0.17 (0.1)
		2	2.13 (1.3)	0.24 (0.1)	1.98 (1.2)	0.22 (0.1)	2.09 (1.3)	0.23 (0.1)
		3	3.46 (2.1)	0.39 (0.2)	3.22 (2.0)	0.36 (0.2)	3.39 (2.1)	0.38 (0.2)
		4	5.11 (3.2)	0.57 (0.4)	4.76 (3.0)	0.53 (0.3)	5.01 (3.1)	0.56 (0.3)
	High	1	7.61 (4.7)	0.85 (0.5)	7.07 (4.4)	0.79 (0.5)	7.45 (4.6)	0.84 (0.5)
		2	10.76 (6.7)	1.21 (0.8)	10.01 (6.2)	1.12 (0.7)	10.55 (6.6)	1.18 (0.7)
		3	17.47 (10.9)	1.96 (1.2)	16.24 (10.1)	1.82 (1.1)	17.12 (10.6)	1.92 (1.2)
		4	25.80 (16.0)	2.90 (1.8)	23.99 (14.9)	2.69 (1.7)	25.28 (15.7)	2.84 (1.8)

The company reserves the right to change the specifications without notice.

W1044901

**[GST Type (with creep speed model)]**

Model		L4630		L5030	
Creep gear shift lever		High	Low	High	Low
Tire size (Rear)		13.6-24		13.6-28	
Shuttle shift lever	Main gear shift lever	km/h (mph)		km/h (mph)	
Forward (At rated engine rpm)	1	1.68 (1.0)	0.19 (0.1)	1.77 (1.1)	0.20 (0.1)
	2	2.38 (1.5)	0.27 (0.2)	2.51 (1.6)	0.28 (0.2)
	3	3.07 (1.9)	0.35 (0.2)	3.24 (2.0)	0.36 (0.2)
	4	3.86 (2.4)	0.43 (0.3)	4.07 (2.5)	0.46 (0.3)
	5	4.54 (2.8)	0.51 (0.3)	4.78 (3.0)	0.54 (0.3)
	6	5.71 (3.5)	0.64 (0.4)	6.02 (3.7)	0.68 (0.4)
	7	6.75 (4.2)	0.76 (0.5)	7.12 (4.4)	0.80 (0.5)
	8	8.49 (5.3)	0.95 (0.6)	8.95 (5.6)	1.00 (0.6)
	9	9.55 (5.9)	1.07 (0.7)	10.07 (6.3)	1.13 (0.7)
	10	12.01 (7.5)	1.35 (0.8)	12.66 (7.9)	1.42 (0.9)
	11	19.49 (12.1)	2.19 (1.4)	20.54 (12.8)	2.31 (1.4)
	12	28.78 (17.9)	3.23 (2.0)	30.34 (18.9)	3.41 (2.1)
Reverse (At rated engine rpm)	1	1.40 (0.9)	0.16 (0.1)	1.48 (0.9)	0.17 (0.1)
	2	1.98 (1.2)	0.22 (0.1)	2.09 (1.3)	0.23 (0.1)
	3	3.22 (2.0)	0.36 (0.2)	3.39 (2.1)	0.38 (0.2)
	4	4.76 (3.0)	0.53 (0.3)	5.01 (3.1)	0.56 (0.3)
	5	7.07 (4.4)	0.79 (0.5)	7.45 (4.6)	0.84 (0.5)
	6	10.01 (6.2)	1.12 (0.7)	10.55 (6.6)	1.18 (0.7)
	7	16.24 (10.1)	1.82 (1.1)	17.12 (10.6)	1.92 (1.2)
	8	23.99 (14.9)	2.69 (1.7)	25.28 (15.7)	2.84 (1.8)

The company reserves the right to change the specifications without notice.

W1032246

**[HST Type]**

Model		L5030
Tire size (Rear)		14.9-26
Shuttle shift lever	Range gear shift lever	km/h (mph)
Forward (At rated engine rpm)	L	0 to 6.10 (0 to 3.8)
	M	0 to 11.80 (0 to 7.3)
	H	0 to 28.60 (0 to 17.8)
Reverse (At rated engine rpm)	L	0 to 5.50 (0 to 3.4)
	M	0 to 10.60 (0 to 6.6)
	H	0 to 25.70 (0 to 16.0)

The company reserves the right to change the specifications without notice.

W1034865

# DIMENSIONS

[L3130, L3430, L3830]

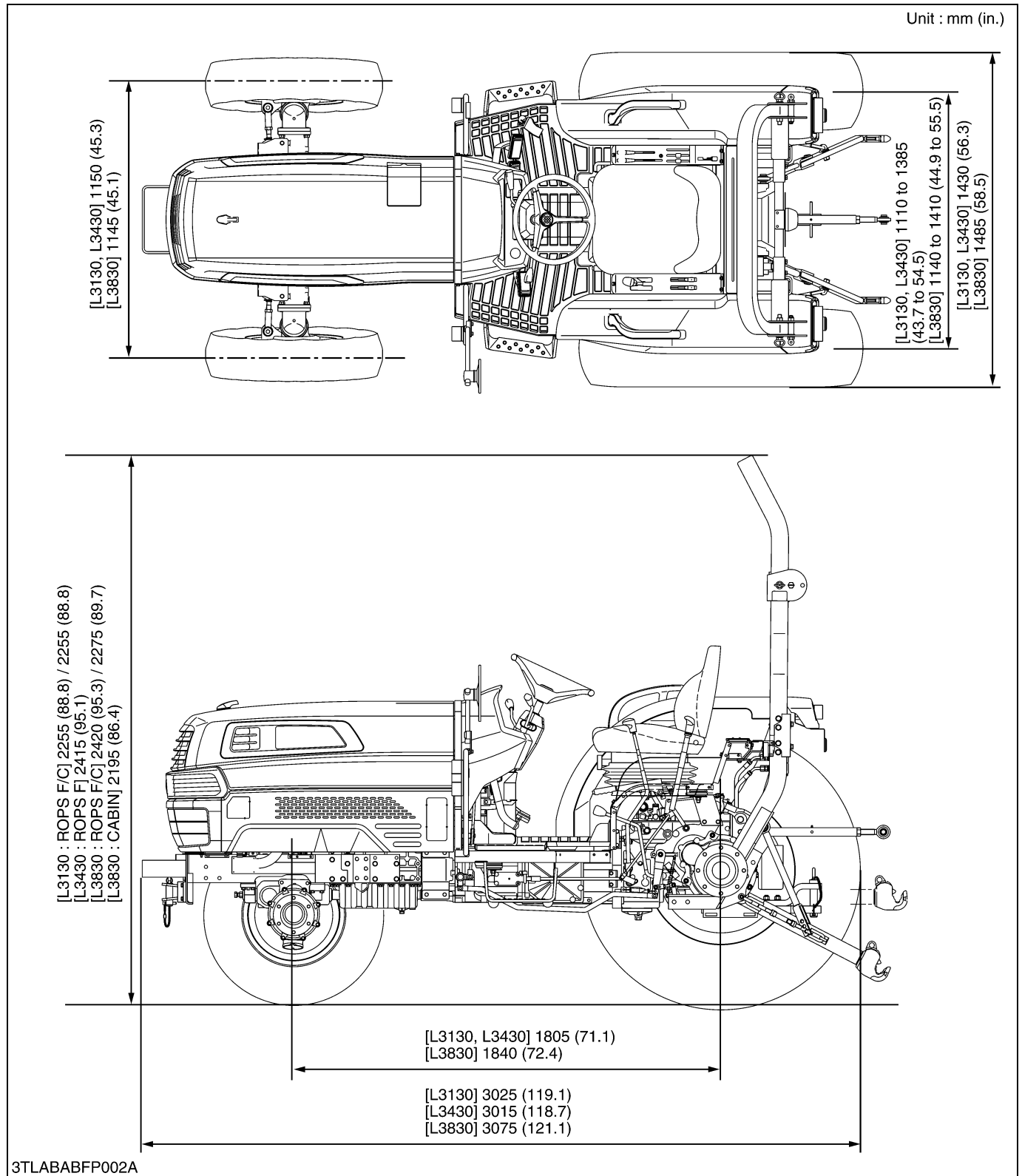

[L4630, L5030]

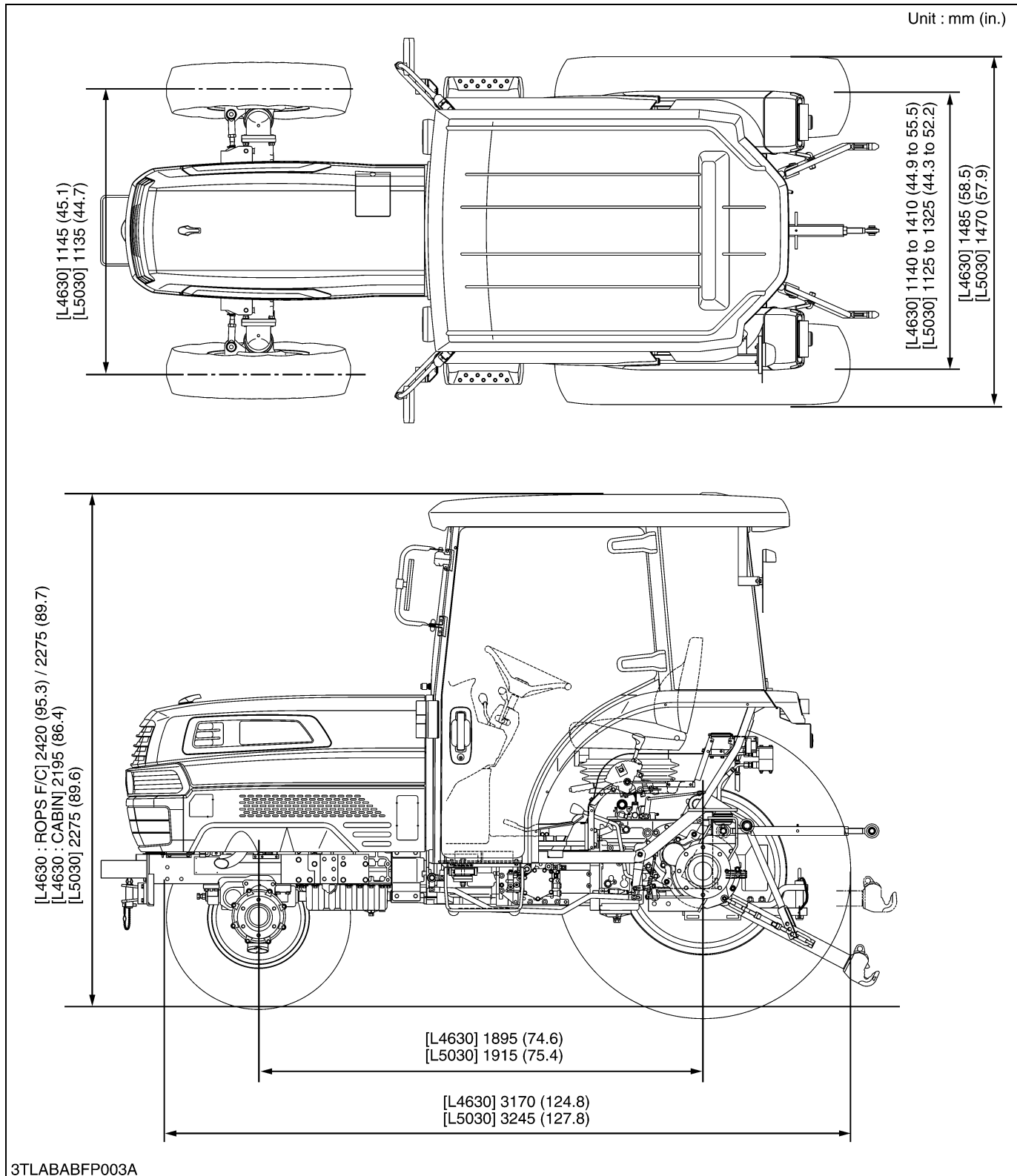

# **G GENERAL**

# GENERAL

## CONTENTS

1. TRACTOR IDENTIFICATION .....	G-1
2. GENERAL PRECAUTIONS .....	G-2
3. HANDLING PRECAUTIONS FOR ELECTRICAL PARTS AND WIRING ..	G-3
[1] WIRING .....	G-3
[2] BATTERY .....	G-5
[3] FUSE .....	G-5
[4] CONNECTOR .....	G-5
[5] HANDLING OF CIRCUIT TESTER .....	G-6
4. LUBRICANTS, FUEL AND COOLANT .....	G-7
5. TIGHTENING TORQUES .....	G-10
[1] GENERAL USE SCREWS, BOLTS AND NUTS .....	G-10
6. MAINTENANCE .....	G-11
7. CHECK AND MAINTENANCE .....	G-14
[1] DAILY CHECK .....	G-14
[2] CHECK POINTS OF INITIAL 50 HOURS .....	G-15
[3] CHECK POINTS OF EVERY 50 HOURS .....	G-19
[4] CHECK POINTS OF EVERY 100 HOURS .....	G-22
[5] CHECK POINTS OF EVERY 200 HOURS .....	G-27
[6] CHECK POINTS OF EVERY 400 HOURS .....	G-31
[7] CHECK POINTS OF EVERY 600 HOURS .....	G-31
[8] CHECK POINTS OF EVERY 800 HOURS .....	G-31
[9] CHECK POINTS OF EVERY 1 YEAR .....	G-32
[10] CHECK POINTS OF EVERY 2 YEARS .....	G-32
[11] OTHERS .....	G-34
8. SPECIAL TOOLS .....	G-39
[1] SPECIAL TOOLS FOR ENGINE .....	G-39
[2] SPECIAL TOOLS FOR TRACTOR .....	G-47
9. TIRES .....	G-55
[1] TIRE PRESSURE .....	G-55
[2] TREADS ADJUSTMENT .....	G-56
(1) Front Wheels .....	G-56
(2) Rear Wheels .....	G-56
[3] TIRE LIQUID INJECTION .....	G-58



# 1. TRACTOR IDENTIFICATION

When contacting your local KUBOTA distributor, always specify engine serial number, tractor serial number and hour meter reading.

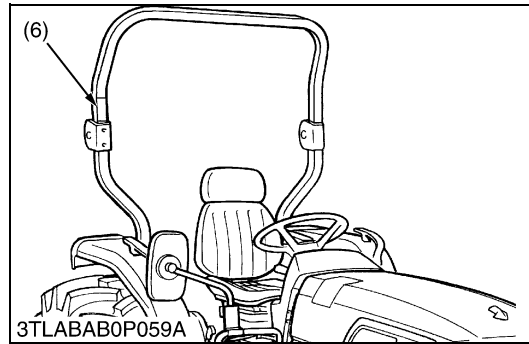
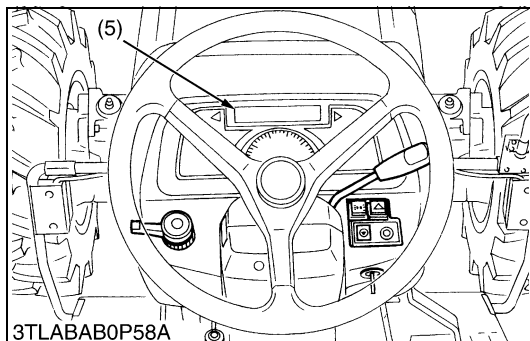
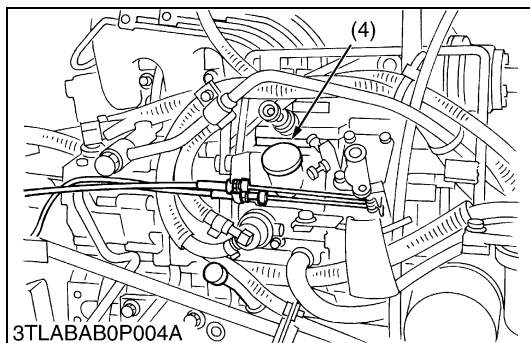
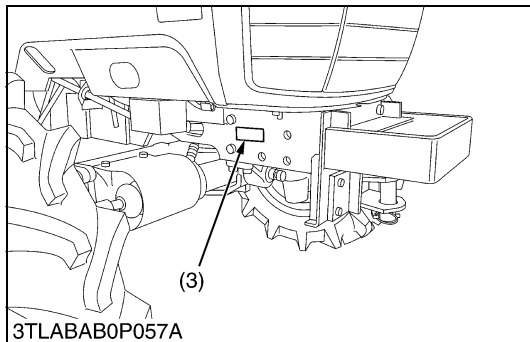
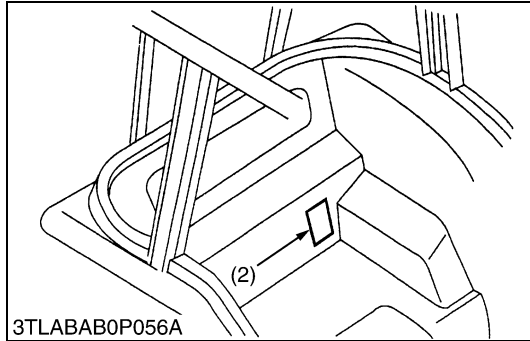
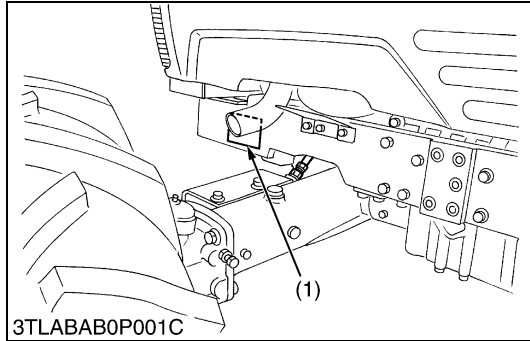

- |   |   |
|---|---|
| (1) Tractor Identification Plate                        | (4) Engine Serial Number                              |
| (2) CABIN Identification Plate<br>(CABIN Serial Number) | (5) Hour Meter (IntelliPanel Display)                 |
| (3) Tractor Serial Number                               | (6) ROPS Identification Plate<br>(ROPS Serial Number) |

W10106000

## 2. GENERAL PRECAUTIONS

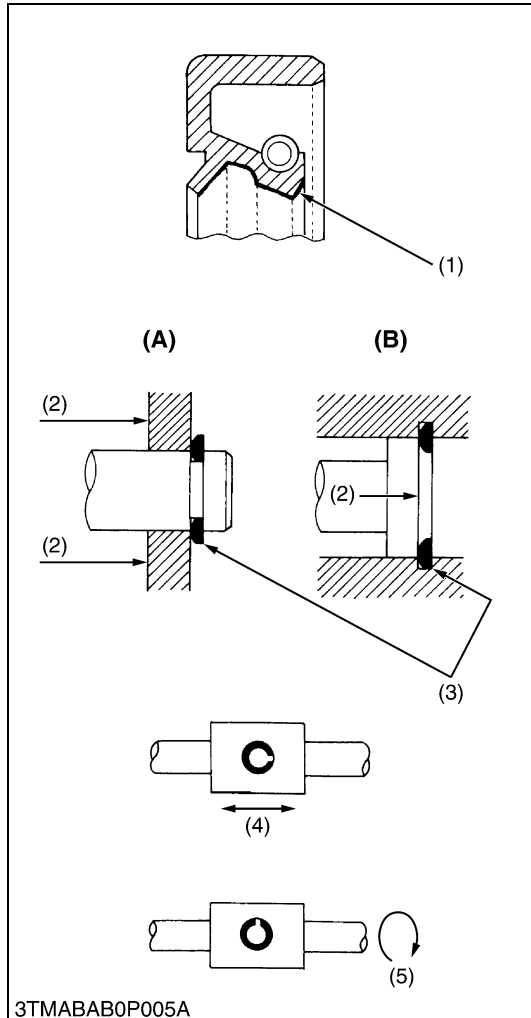

- During disassembly, carefully arrange removed parts in a clean area to prevent confusion later. Screws, bolts and nuts should be installed in their original position to prevent reassembly errors.
- When special tools are required, use KUBOTA genuine special tools. Special tools which are not frequently used should be made according to the drawings provided.
- Before disassembling or servicing electrical wires, always disconnect the ground cable from the battery first.
- Remove oil and dirt from parts before measuring.
- Use only KUBOTA genuine parts for parts replacement to maintain machine performance and to assure safety.
- Gaskets and O-rings must be replaced during reassembly. Apply grease to new O-rings or oil seals before assembling. See the figure left side.
- When reassembling external snap rings or internal snap rings, they must be positioned so that sharp edge faces against the direction from which a force is applied. See the figure left side.
- When inserting spring pins, their splits must face the direction from which a force is applied. See the figure left side.
- To prevent damage to the hydraulic system, use only specified fluid or equivalent.

- (1) Grease
- (2) Force
- (3) Sharp Edge
- (4) Axial Force
- (5) Rotating Movement

- (A) External Snap Ring
- (B) Internal Snap Ring

W10109040

### 3. HANDLING PRECAUTIONS FOR ELECTRICAL PARTS AND WIRING

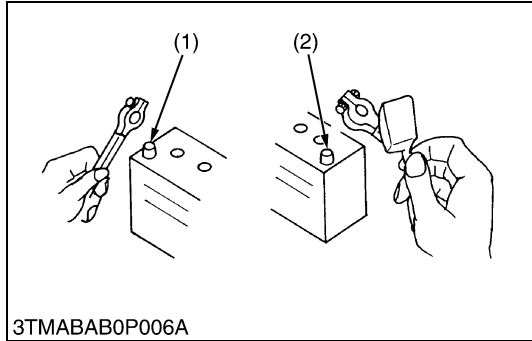

3TMABAB0P006A

To ensure safety and prevent damage to the machine and surrounding equipment, heed the following precautions in handling electrical parts and wiring.

**■ IMPORTANT**

- Check electrical wiring for damage and loosened connection every year. To this end, educate the customer to do his or her own check and at the same time recommend the dealer to perform periodic check for a fee.
- Do not attempt to modify or remodel any electrical parts and wiring.
- When removing the battery cables, disconnect the negative cable first. When installing the battery cables, connect the positive cable first.

- (1) Negative Terminal (2) Positive Terminal

W10111140

#### [1] WIRING

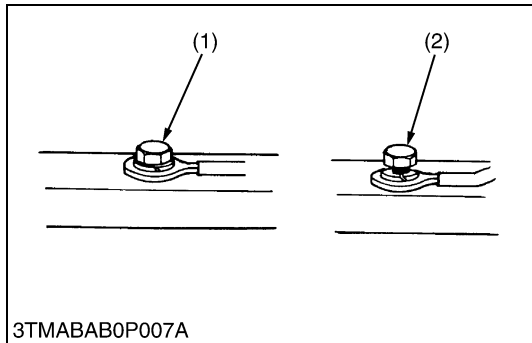

3TMABAB0P007A

- Securely tighten wiring terminals.

- (1) Correct (Securely Tighten) (2) Incorrect (Loosening Leads to Faulty Contact)

W10112160

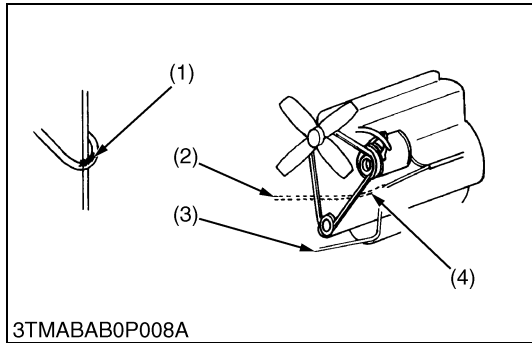

3TMABAB0P008A

- Do not let wiring contact dangerous part.

- (1) Wiring (Correct) (2) Wiring (Incorrect) (3) Dangerous Part (4) Dangerous Part

W10113130

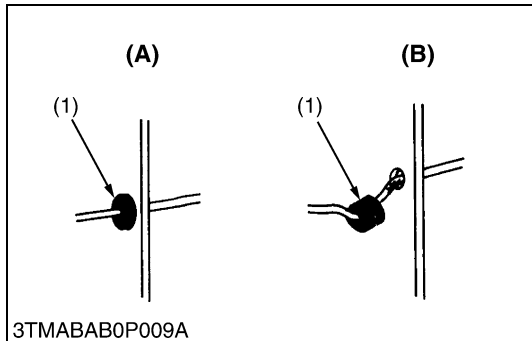

3TMABAB0P009A

- Securely insert grommet.

- (1) Grommet (A) Correct (B) Incorrect

W10113880

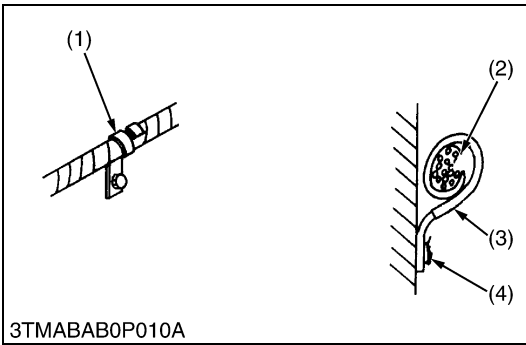

- Securely clamp, being careful not to damage wiring.

- (1) Clamp
  - Wind Clamp Spirally
- (2) Wire Harness
- (3) Clamp
- (4) Welding Dent

W10114580

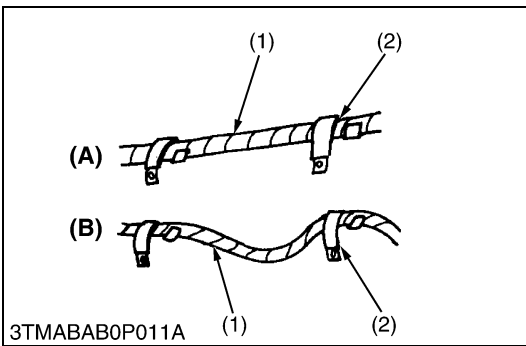

- Clamp wiring so that there is no twist, unnecessary sag, or excessive tension, except for movable part, where sag be required.

- (1) Wiring
- (2) Clamp
- (A) Correct
- (B) Incorrect

W10115870

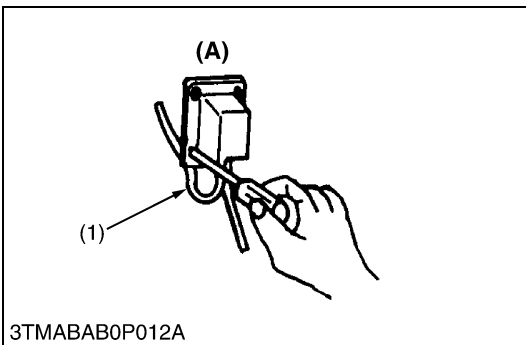

- In installing a part, take care not to get wiring caught by it.

- (1) Wiring
- (A) Incorrect

W10116700

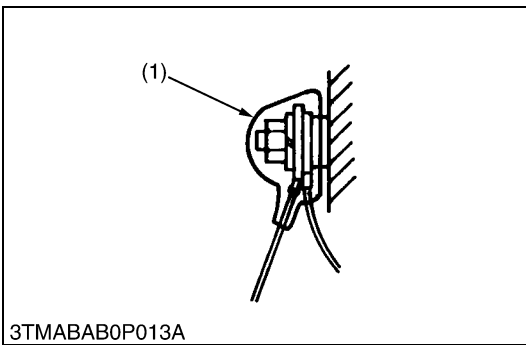

- After installing wiring, check protection of terminals and clamped condition of wiring, only connect battery.

- (1) Cover
  - Securely Install Cover

W10117350

## [2] BATTERY

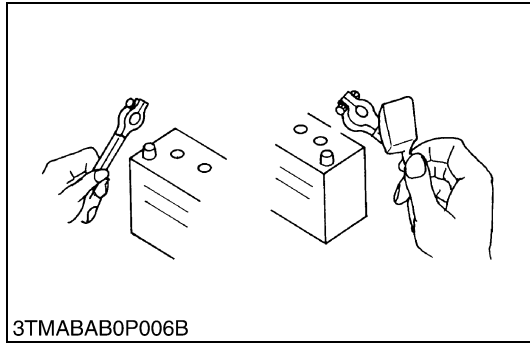

- Take care not to confuse positive and negative terminal posts.
- When removing battery cables, disconnect negative cable first. When installing battery cables, check for polarity and connect positive cable first.
- Do not install any battery with capacity other than is specified (Ah).
- After connecting cables to battery terminal posts, apply high temperature grease to them and securely install terminal covers on them.
- Do not allow dirt and dust to collect on battery.

### **⚠ CAUTION**

- Take care not to let battery liquid spill on your skin and clothes. If contaminated, wash it off with water immediately.
- Before recharging the battery, remove it from the machine.
- Before recharging, remove cell caps.
- Do recharging in a well-ventilated place where there is no open flame nearby, as hydrogen gas and oxygen are formed.

W10118160

## [3] FUSE

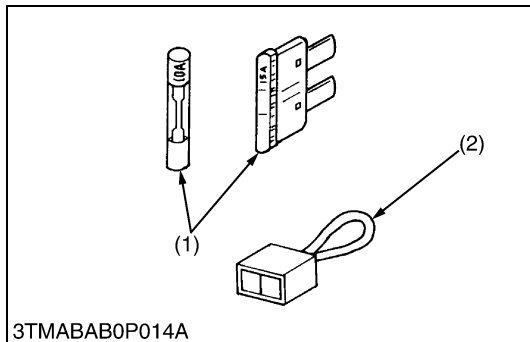

- Use fuses with specified capacity. Neither too large or small capacity fuse is acceptable.
- Never use steel or copper wire in place of fuse.
- Do not install working light, radio set, etc. on machine which is not provided with reserve power supply.
- Do not install accessories if fuse capacity of reserve power supply is exceeded.

(1) Fuse

(2) Slow Blow Fuse

W10120920

## [4] CONNECTOR

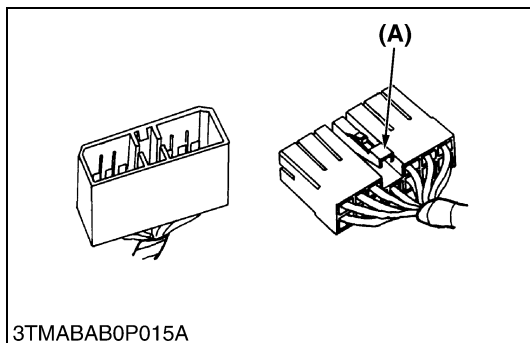

- For connector with lock, push lock to separate.

(A) Push

W10122110

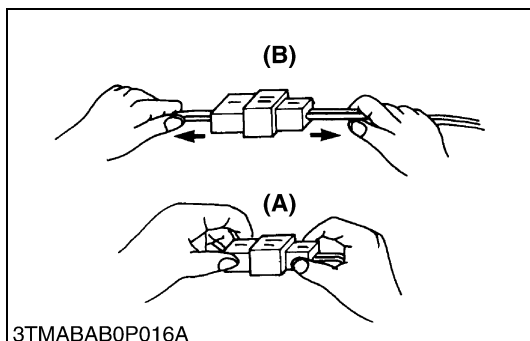

- In separating connectors, do not pull wire harnesses.
- Hold connector bodies to separate.

(A) Correct

(B) Incorrect

W10122720

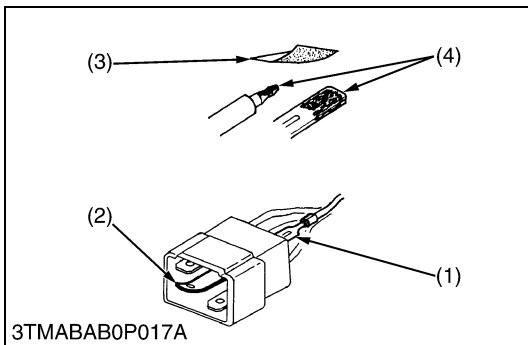

- Use sandpaper to remove rust from terminals.
- Repair deformed terminal. Make certain there is no terminal being exposed or displaced.

(1) Exposed Terminal (3) Sandpaper  
 (2) Deformed Terminal (4) Rust

W10123460

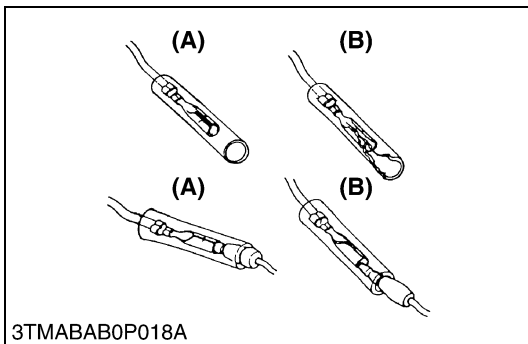

- Make certain that there is no female connector being too open.

(A) Correct (B) Incorrect

W10124300

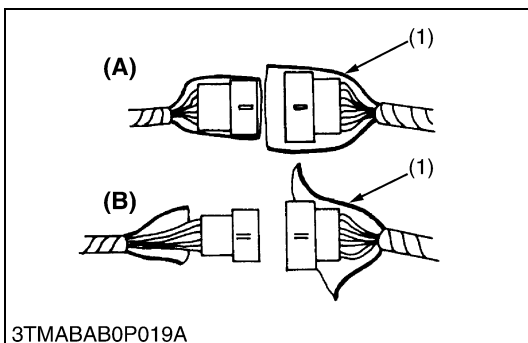

- Make certain plastic cover is large enough to cover whole connector.

(1) Cover (A) Correct  
 (B) Incorrect

W10125190

## [5] HANDLING OF CIRCUIT TESTER

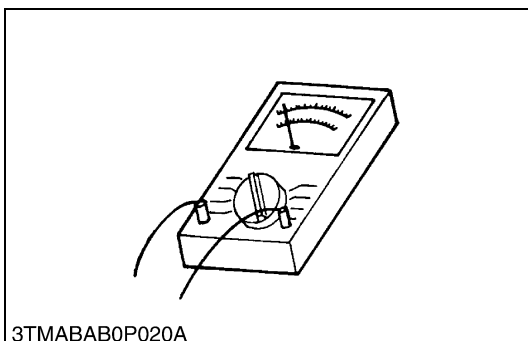

- Use tester correctly following manual provided with tester.
- Check for polarity and range.

W10126840

## 4. LUBRICANTS, FUEL AND COOLANT

	Place	Capacity			Lubricants, fuel and coolant
		L3130	L3430	L3830	
1	Fuel tank	40 L 10.6 U.S.gals 8.8 Imp.gals			No. 2-D diesel fuel No. 1-D diesel fuel if temperature is below -10 °C (14 °F)
2	Cooling system (ROPS Type)	6.0 L 6.3 U.S.qts 5.3 Imp.qts		7.5 L 7.9 U.S.qts 6.6 Imp.qts	Fresh clean water with anti-freeze
	Cooling system (CABIN Type)	-		8.7 L 9.2 U.S.qts 7.7 Imp.qts	
3	Engine crankcase (with filter)	5.7 L 6.0 U.S.qts 5.0 Imp.qts		6.7 L 7.1 U.S.qts 5.9 Imp.qts	Engine oil : API service classification CD, CE or CF Above 25 °C : SAE30, (77 °F) 10W-30 or 10W-40 0 to 25 °C : SAE20, (32 to 77 °F) 10W-30 or 10W-40 Below 0 °C : SAE10W, (32 °F) 10W-30 or 10W-40
4	Transmission case	42 L 11.1 U.S.gals 9.2 Imp.gals		43 L 11.4 U.S.gals 9.5 Imp.gals	KUBOTA UDT or SUPER UDT fluid*
5	Front axle case	6.5 L 6.9 U.S.qts 5.7 Imp.qts			KUBOTA UDT or SUPER UDT fluid* or SAE80, 90 gear oil
<b>Greasing</b>					
	Place	No. of greasing point		Capacity	Type of grease
6	Front axle support	2		Until grease overflows	Multipurpose type grease
	Top link	2			
	Top link bracket (if equipped)	2 (with draft control)			
	Lift rod	1			
	Lift cylinder	4			
	Battery terminal	2		Moderate amount	Engine oil
	Throttle cable	Oiling			

\* KUBOTA original transmission hydraulic fluid.

	Place	Capacity		Lubricants, fuel and coolant
		L4630	L5030	
1	Fuel tank	40 L 10.6 U.S.gals 8.8 Imp.gals	43 L 11.4 U.S.gals 9.5 Imp.gals	No. 2-D diesel fuel No. 1-D diesel fuel if temperature is below -10 °C (14 °F)
2	Cooling system (ROPS Type)	7.5 L 7.9 U.S.qts 6.6 Imp.qts	8.0 L 8.5 U.S.qts 7.0 Imp.qts	Fresh clean water with anti-freeze
	Cooling system (CABIN Type)	8.7 L 9.2 U.S.qts 7.7 Imp.qts	9.2 L 9.7 U.S.qts 8.1 Imp.qts	
3	Engine crankcase (with filter)	8.2 L 8.7 U.S.qts 7.2 Imp.qts		Engine oil : API service classification CD, CE or CF Above 25 °C : SAE30, (77 °F) 10W-30 or 10W-40 0 to 25 °C : SAE20, (32 to 77 °F) 10W-30 or 10W-40 Below 0 °C : SAE10W, (32 °F) 10W-30 or 10W-40
4	Transmission case	43 L 11.4 U.S.gals 9.5 Imp.gals	45 L 11.9 U.S.gals 9.9 Imp.gals	KUBOTA UDT or SUPER UDT fluid*
5	Front axle case	6.5 L 6.9 U.S.qts 5.7 Imp.qts	6.0 L 6.3 U.S.qts 5.3 Imp.qts	KUBOTA UDT or SUPER UDT fluid* or SAE80, 90 gear oil
<b>Greasing</b>				
	Place	No. of greasing point	Capacity	Type of grease
6	Front axle case support	2	Until grease overflows	Multipurpose type grease
	Front axle support	2		
	Top link	2		
	Top link bracket (if equipped)	2 (with draft control)		
	Lift rod	1		
	Lift cylinder	4		
	Battery terminal	2	Moderate amount	Engine oil
Throttle cable	Oiling			

\* KUBOTA original transmission hydraulic fluid.



## ■ NOTE

### Engine Oil

- Oil used in the engine should have an American Petroleum Institute (API) service classification and Proper SAE Engine Oil according to the ambient temperatures as shown above.
- With the emission control now in effect, the CF-4 and CG-4 lubricating oils have been developed for use of a low-sulfur fuel on on-road vehicle engines. When an off-road vehicle engine runs on a high-sulfur fuel, it is advisable to employ the CF, CD or CE lubricating oil with a high total base number. **If the CF-4 or CG-4 lubricating oil is used with a high-sulfur fuel, change the lubricating oil at shorter intervals.**
- Lubricating oil recommended when a low-sulfur or high-sulfur fuel is employed.

Lubricating oil class	Fuel		Remarks
	Low sulfur	High sulfur	
CF	○	○	TBN ≥ 10
CF-4	○	X	
CG-4	○	X	



○ : Recommendable X : Not recommendable

W1035555

## 5. TIGHTENING TORQUES

Screws, bolts and nuts whose tightening torques are not specified in this Workshop Manual should be tightened according to tables below.

### [1] GENERAL USE SCREWS, BOLTS AND NUTS

Indication on top of bolt	 No-grade or 4T						 7T						 9T		
Material of bolt	SS400, S20C						S43C, S48C						SCr435, SCM435		
Material of opponent part	Ordinariness			Aluminum			Ordinariness			Aluminum			Ordinariness		
Unit															
Diameter	N-m	kgf-m	ft-lbs	N-m	kgf-m	ft-lbs	N-m	kgf-m	ft-lbs	N-m	kgf-m	ft-lbs	N-m	kgf-m	ft-lbs
M6 (6 mm, 0.24 in.)	7.85 to 9.31	0.80 to 0.95	5.79 to 6.87	7.85 to 8.82	0.80 to 0.90	5.79 to 6.50	9.81 to 11.2	1.00 to 1.15	7.24 to 8.31	7.85 to 8.82	0.80 to 0.90	5.79 to 6.50	12.3 to 14.2	1.25 to 1.45	9.05 to 10.4
M8 (8 mm, 0.31 in.)	17.7 to 20.5	1.8 to 2.1	13.1 to 15.1	16.7 to 19.6	1.7 to 2.0	12.3 to 14.4	23.6 to 27.4	2.4 to 2.8	17.4 to 20.2	17.7 to 20.5	1.8 to 2.1	13.1 to 15.1	29.5 to 34.3	3.0 to 3.5	21.7 to 25.3
M10 (10 mm, 0.39 in.)	39.3 to 45.1	4.0 to 4.6	29.0 to 33.2	31.4 to 34.3	3.2 to 3.5	23.2 to 25.3	48.1 to 55.8	4.9 to 5.7	35.5 to 41.2	39.3 to 44.1	4.0 to 4.5	29.0 to 32.5	60.9 to 70.6	6.2 to 7.2	44.9 to 52.0
M12 (12 mm, 0.47 in.)	62.8 to 72.5	6.4 to 7.4	46.3 to 53.5	–	–	–	77.5 to 90.2	7.9 to 9.2	57.2 to 66.5	62.8 to 72.5	6.4 to 7.4	46.3 to 53.5	103 to 117	10.5 to 12.0	76.0 to 86.7
M14 (14 mm, 0.55 in.)	108 to 125	11.0 to 12.8	79.6 to 92.5	–	–	–	124 to 147	12.6 to 15.0	91.2 to 108	–	–	–	167 to 196	17.0 to 20.0	123 to 144
M16 (16 mm, 0.63 in.)	167 to 191	17.0 to 19.5	123 to 141	–	–	–	197 to 225	20.0 to 23.0	145 to 166	–	–	–	260 to 304	26.5 to 31.0	192 to 224
M18 (18 mm, 0.71 in.)	246 to 284	25.0 to 29.0	181 to 209	–	–	–	275 to 318	28.0 to 32.5	203 to 235	–	–	–	344 to 402	35.0 to 41.0	254 to 296
M20 (20 mm, 0.79 in.)	334 to 392	34.0 to 40.0	246 to 289	–	–	–	368 to 431	37.5 to 44.0	272 to 318	–	–	–	491 to 568	50.0 to 58.0	362 to 419

W10345420

## 6. MAINTENANCE

No.	Item		Period	Indication on hour meter										Important	Reference page
				50	100	150	200	250	300	350	400	450	500		
1	Brake	Adjust	★	☆		☆		☆		☆		☆			G-18
2	Engine oil	Change	★	☆		☆		☆		☆		☆			G-15
3	Engine oil filter	Replace	★			☆				☆					G-15
4	Hydraulic oil filter	Replace	★			☆				☆					G-16
5	Transmission fluid	Change	★							☆					G-17
6	Front axle case oil	Change	★							☆					G-18
7	Engine start system	Check	☆	☆	☆	☆	☆	☆	☆	☆	☆	☆			G-20, 21
8	Wheel bolt torque	Check	☆	☆	☆	☆	☆	☆	☆	☆	☆	☆			G-21
9	Greasing	–	☆	☆	☆	☆	☆	☆	☆	☆	☆	☆			G-19
10	Battery condition	Check		☆		☆		☆		☆		☆	*5		G-25
11	Air cleaner element [Double type]	Primary element	Clean		☆		☆		☆		☆		☆	*1	G-22
			Replace											*2	G-32
		Secondary element	Replace												
12	Clutch	Adjust		☆		☆		☆		☆		☆			G-24
13	Parking brake (cable)	Adjust		☆		☆		☆		☆		☆			G-27
		Replace													G-27
14	Fuel filter element	Clean		☆		☆		☆		☆		☆			G-23
		Replace								☆					G-31
15	Fan belt	Adjust		☆		☆		☆		☆		☆			G-23
16	Fuel line	Check		☆		☆		☆		☆		☆			G-24
		Replace													G-32
17	Transmission oil filter [HST]	Replace				☆				☆					G-16
18	HST oil line [HST]	Check				☆				☆					G-29
		Replace											*3		G-32
19	Radiator hose and clamp	Check				☆				☆					G-27
		Replace													G-32
20	Power steering oil line	Check				☆				☆					G-29
		Replace													G-32
21	Toe-in	Adjust				☆				☆					G-28
22	Front axle pivot	Adjust					☆								G-31
23	Engine valve clearance	Adjust						☆					*4		1-S27
24	Cooling system	Flush										☆			G-33
25	Coolant	Change										☆			G-33
26	Fuel system	Bleed													G-34
27	Clutch housing water	Drain													G-35
28	Fuse	Replace													G-36
29	Light bulb	Replace													G-37

### ■ IMPORTANT

- The jobs indicated by ★ must be done after the first 50 hours of operation.
- \*1 : Air cleaner should be cleaned more often in dusty conditions than in normal conditions.
- \*2 : Every year or every 6 times of cleaning.
- \*3 : Replace only if necessary.
- \*4 : Consult your local KUBOTA distributor for this service.
- \*5 : When the battery is used for less than 100 hours per year, check the battery condition by reading the indication annually.
- The items listed above (@ marked) are registered as emission related critical parts by KUBOTA in the U.S.EPA nonroad emission regulation. As the engine owner, you are responsible for the performance of the required maintenance on the engine according to the above instruction. Please see the Warranty Statement in detail.

W10357690

No.	Item		Period	Indication on hour meter						After purchase		Important	Reference page
				550	600	650	700	750	800	1 year	2 years		
1	Brake		Adjust		☆		☆		☆				G-18
2	Engine oil		Change		☆		☆		☆				G-15
3	Engine oil filter		Replace		☆				☆				G-15
4	Hydraulic oil filter		Replace		☆				☆				G-16
5	Transmission fluid		Change						☆				G-17
6	Front axle case oil		Change						☆				G-18
7	Engine start system		Check	☆	☆	☆	☆	☆	☆				G-20, 21
8	Wheel bolt torque		Check	☆	☆	☆	☆	☆	☆				G-21
9	Greasing		—	☆	☆	☆	☆	☆	☆				G-19
10	Battery condition		Check		☆		☆		☆			*5	G-25
11	Air cleaner element [Double type]	Primary element	Clean		☆		☆		☆			*1	G-22
			Replace								☆		*2
		Secondary element	Replace								☆		
12	Clutch		Adjust		☆		☆		☆				G-24
13	Parking brake (cable)		Adjust		☆		☆		☆				G-27
			Replace								☆		
14	Fuel filter element		Clean		☆		☆		☆				G-23
			Replace								☆		
15	Fan belt		Adjust		☆		☆		☆				G-23
16	Fuel line		Check		☆		☆		☆				G-24
			Replace								☆		*3
17	Transmission oil filter [HST]		Replace		☆				☆				G-16
18	HST oil line [HST]		Check		☆				☆				G-29
			Replace								☆		
19	Radiator hose and clamp		Check		☆				☆				G-27
			Replace								☆		
20	Power steering oil line		Check		☆				☆				G-29
			Replace								☆		
21	Toe-in		Adjust		☆				☆				G-28
22	Front axle pivot		Adjust		☆								G-31
23	Engine valve clearance		Adjust						☆			*4	1-S27
24	Cooling system		Flush								☆		G-33
25	Coolant		Change								☆		G-33
26	Fuel system		Bleed										G-34
27	Clutch housing water		Drain										G-35
28	Fuse		Replace										G-36
29	Light bulb		Replace										G-37

### ■ IMPORTANT

- The jobs indicated by ★ must be done after the first 50 hours of operation.
- \*1 : Air cleaner should be cleaned more often in dusty conditions than in normal conditions.
- \*2 : Every year or every 6 times of cleaning.
- \*3 : Replace only if necessary.
- \*4 : Consult your local KUBOTA distributor for this service.
- \*5 : When the battery is used for less than 100 hours per year, check the battery condition by reading the indication annually.
- The items listed above (@ marked) are registered as emission related critical parts by KUBOTA in the U.S.EPA nonroad emission regulation. As the engine owner, you are responsible for the performance of the required maintenance on the engine according to the above instruction. Please see the Warranty Statement in detail.

W10511390

**(Only the Check Points Different from Those for Tractors with CABIN)**

No.	Item	Period	Indication on hour meter										Important	Reference page	
			50	100	150	200	250	300	350	400	450	500			
1	Clogging of air conditioner condenser screen	Clean												Daily	–
2	Tension of air conditioner drive belt	Adjust				☆									G-29
3	Clogging of inner air filter	Clean				☆									G-30
4	Clogging of fresh air filter	Clean				☆									G-30
5	Clogging of air conditioner condenser	Check				☆									G-31
6	Air conditioner pipes and hoses	Check													G-32
7	CABIN isolation cushion	Check													G-32
8	Lubricating points	Check	Service as required											G-37	
9	Washer liquid	Check												G-37	
10	Amount of refrigerant (gas)	Check												G-38	

W11154790

**(Only the Check Points Different from Those for Tractors with CABIN)**

No.	Item	Period	Indication on hour meter						After purchase		Important	Reference page
			550	600	650	700	750	800	1 year	2 years		
1	Clogging of air conditioner condenser screen	Clean									Daily	–
2	Tension of air conditioner drive belt	Adjust										G-29
3	Clogging of inner air filter	Clean										G-30
4	Clogging of fresh air filter	Clean										G-30
5	Clogging of air conditioner condenser	Check										G-31
6	Air conditioner pipes and hoses	Check								☆		G-32
7	CABIN isolation cushion	Check								☆		G-32
8	Lubricating points	Check	Service as required								G-37	
9	Washer liquid	Check								G-37		
10	Amount of refrigerant (gas)	Check								G-38		

W10606470

## 7. CHECK AND MAINTENANCE



### CAUTION

- **Be sure to check and service the tractor on a flat place with engine shut off, the parking brake on and chock the wheels.**

### [1] DAILY CHECK

To prevent trouble from occurring, it is important to know the condition of the tractor. Check the following items before starting.

#### Checking

- Check areas where previous trouble was experienced.
  - Walk around the tractor.
1. Check the tire pressure, and check for wear and damage.
  2. Check for oil and water leak.
  3. Check the engine oil level.
  4. Check the transmission fluid level.
  5. Check the coolant level.
  6. Check the condition of ROPS attaching hardware.
  7. Check and clean the radiator screen, grill and oil cooler. (HST only)
  8. Check and clean the air condenser screen. (CABIN only)
  9. Check the screws and nuts of tires are tight.
  10. Check the number plate.
  11. Care of danger, warning and caution labels.
  12. Clean around the exhaust manifold and the muffler of the engine.
  13. Check the fuel level.
  14. Check the dust indicator.
    - While sitting in the operator's seat.
      1. Check the brake pedals and clutch pedal.
      2. Check the parking brake.
      3. Check the steering wheel.
        - Turning the key switch.
          1. Check the performance of the easy checker lights.
          2. Check the lights, turn signal lights, hazard lights and other light equipment. Clean if necessary.
          3. Check the performance of the meters and gauges.
            - Starting the engine.
              1. Check to see that the lights on the easy checker go off.
              2. Check the color of the exhaust gas.
              3. Check the brakes for proper operation.

## [2] CHECK POINTS OF INITIAL 50 HOURS

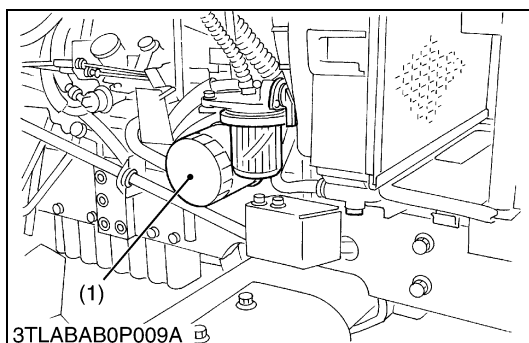
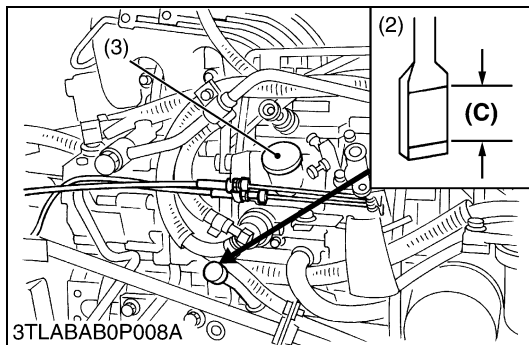
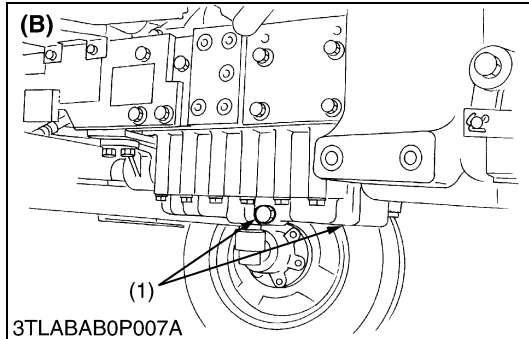
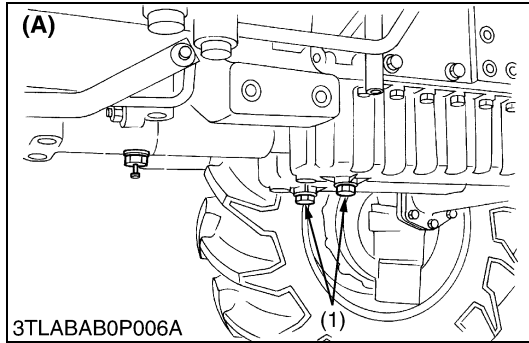

### Changing Engine Oil

#### ⚠ CAUTION

- Before changing oil, be sure to stop the engine.
- Allow engine to cool down sufficiently, oil can be hot and can burn.

1. Start and warm up the engine for approx. 5 minutes.
2. Place an oil pan underneath the engine.
3. To drain the used oil, remove the both drain plugs (1) at the bottom of the engine and drain the oil completely.
4. Screw in the both drain plugs (1).
5. Fill new oil up to upper line on the dipstick (2).

#### ■ IMPORTANT

- When using an oil of different manufacture or viscosity from the previous one, remove all of the old oil.
- Never mix two different types of oil.
- Use the proper SAE Engine Oil according to ambient temperatures.
- Refer to "LUBRICANTS, FUEL AND COOLANT". (See page G-7, 8.)

Engine oil capacity (with filter)	L3130 L3430	5.7 L 6.0 U.S.qts 5.0 Imp.qts
	L3830	6.7 L 7.1 U.S.qts 5.9 Imp.qts
	L4630 L5030	8.2 L 8.7 U.S.qts 7.2 Imp.qts

- (1) Drain Plug  
(2) Dipstick  
(3) Oil Inlet

(A) L3130, L3430, L4630, L5030

(B) L3830

(C) Oil level is acceptable within this range.

W10145330

### Replacing Engine Oil Filter Cartridge

#### ⚠ CAUTION

- Be sure to stop the engine before changing oil filter cartridge.
- Allow engine to cool down sufficiently, oil can be hot and can burn.

1. Remove the oil filter cartridge with the filter wrench.
2. Apply a slight coat of oil onto the new cartridge gasket.
3. To install the new cartridge, screw it in by hand. Over tightening may cause deformation of rubber gasket.
4. After the new cartridge has been replaced, the engine oil normally decrease a little. Thus see that the engine oil does not leak through the seal and be sure to read the oil level on the dipstick. Then, replenish the engine oil up to the specified level.

#### ■ IMPORTANT

- To prevent serious damage to the engine, replacement element must be highly efficient. Use only a KUBOTA genuine filter or its equivalent.

- (1) Engine Oil Filter Cartridge

W10148920

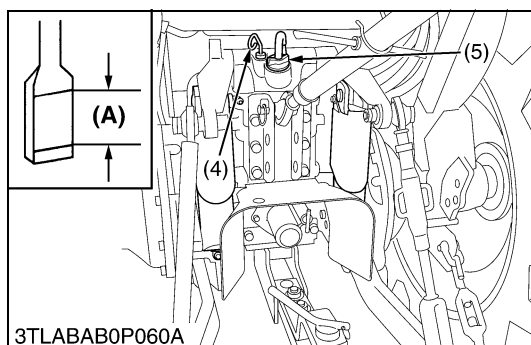
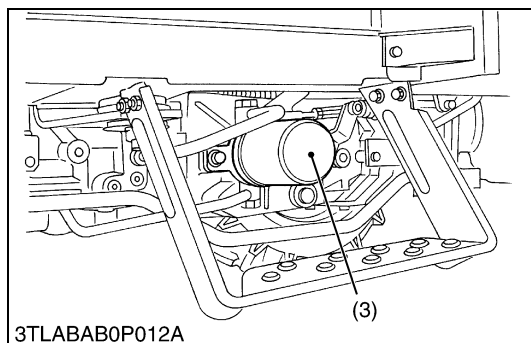
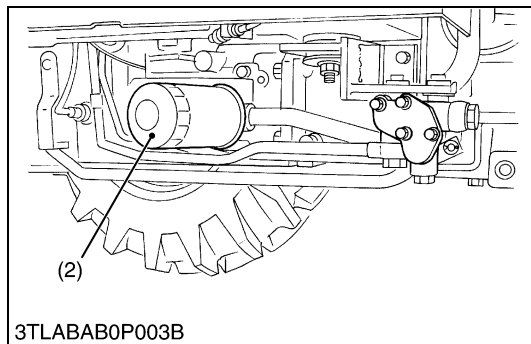
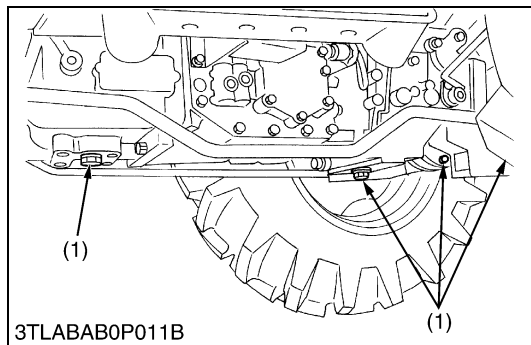

### Replacing Hydraulic Oil Filter / Replacing Transmission Oil Filter [HST Type]

#### ⚠ CAUTION

- Be sure to stop the engine before changing the oil filter cartridge.
- Allow engine to cool down sufficiently, oil can be hot and can burn.

1. Remove the drain plugs at the bottom of the transmission case drain the oil completely into the oil pan.
2. After draining reinstall the drain plugs.
3. Remove the oil filter.
4. Put a film of clean transmission oil on the rubber seal of the new filter.
5. [Hydraulic oil filter]  
Quickly tighten the filter until it contacts the mounting surface, then tighten it by hand an additional 1/2 turn only.  
[Transmission oil filter]  
Quickly tighten the filter until it contacts the mounting surface, then with a filter wrench, tighten it an additional 1 turn only.
6. After the new filters have been replaced, fill the transmission oil up to the upper notch on the dipstick.
7. After running the engine for a few minutes, stop the engine and check the oil level again, add oil to the prescribed level.
8. Make sure that the transmission fluid does not leak past the seal on the filter.

#### ■ IMPORTANT

- To prevent serious damage to the hydraulic system, use only a KUBOTA genuine filter.

- (1) Drain Plugs  
 (2) Hydraulic Oil Filter  
 (3) Transmission Oil Filter [HST Type]  
 (4) Dipstick  
 (5) Oil Inlet

(A) Oil level is acceptable within this range.

W1064569



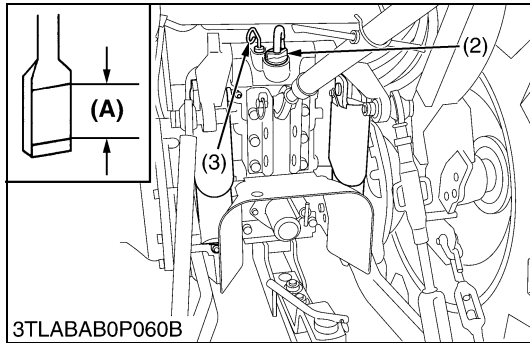
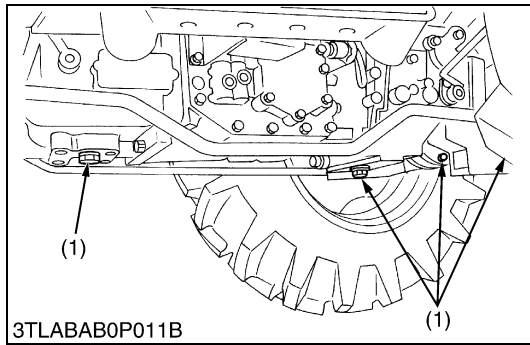

## Changing Transmission Fluid

### ⚠ CAUTION

- Be sure to stop the engine checking and changing the transmission fluid.
- Allow engine to cool down sufficiently, oil can be hot and can burn.

1. Place an oil pan under the tractor.
2. Remove the drain plugs (1) at the bottom of the transmission case.
3. Drain the transmission fluid.
4. After draining, screw in the drain plugs.
5. Fill new oil from filling port after removing the filling plug (2) up to the upper line of the dipstick (3).
6. After running the engine for a few minutes, stop it and check the oil level again, if low, add oil prescribed level.

### ■ IMPORTANT

- Use only multi-grade transmission oil. Use of other oils may damage the transmission or hydraulic system. Refer to "LUBRICANTS, FUEL AND COOLANT". (See page G-7, 8.)
- Never work the tractor immediately after changing the transmission oil. Keeping the engine at medium speed for a few minutes to prevents damage to the transmission.
- Do not mix different brands oil together.

Transmission fluid capacity	L3130, L3430	42 L 11.1 U.S.gals 9.2 Imp.gals
	L3830, L4630	43 L 11.4 U.S.gals 9.5 Imp.gals
	L5030	45 L 11.9 U.S.gals 9.9 Imp.gals

- (1) Drain Plug  
(2) Filling Plug  
(3) Dipstick

(A) Oil level is acceptable within this range.

W1068655

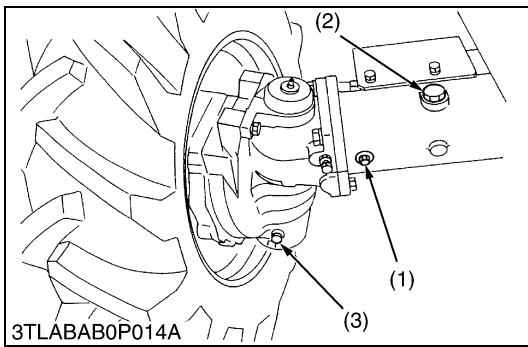

### Changing Front Axle Case Oil

#### ⚠ CAUTION

- Be sure to stop the engine before changing the front axle case oil.
  - Allow engine to cool down sufficiently, oil can be hot and can burn.
1. Remove the right and left drain plugs (3) and filling plug (2) at the front axle case and drain the oil completely.
  2. After draining, reinstall the drain plugs (3).
  3. Remove the right and left check plugs (1).
  4. Fill new oil from filling port with specified amount of oil.  
Refer to “**LUBRICANTS, FUEL AND COOLANT**”. (See page G-7, 8.)
  5. Reinstall the filling plug (2) and check plug (1).

Front axle case oil capacity	L3130 L3430 L3830 L4630	6.5 L 6.9 U.S.qts 5.7 Imp.qts
	L5030	6.0 L 6.3 U.S.qts 5.3 Imp.qts

(1) Check Plug  
(2) Filling Plug

(3) Drain Plug

W10300640

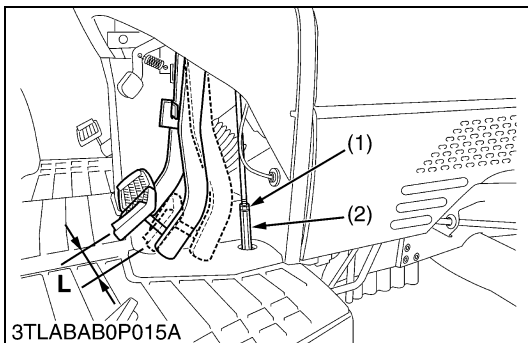

### Adjusting Brake Pedal Free Travel

#### ⚠ CAUTION

- Stop the engine and chock the wheels before checking brake pedal.
1. Release the parking brake.
  2. Slightly depress the brake pedals and measure free travel (L) at top of pedal stroke.
  3. If the measurement is not within the factory specifications, loosen the lock nut (1) and turn the turnbuckle (2) to adjust the rod length within acceptable limits.
  4. Retighten the lock nut (1) securely.  
Keep the free travel in the right and left brake pedals equal.

Brake pedal free travel “L”	Factory spec.	15 to 20 mm 0.59 to 0.79 in.
-----------------------------	---------------	---------------------------------

(1) Lock Nut  
(2) Turnbuckle

L : Free Travel

W10293350

### [3] CHECK POINTS OF EVERY 50 HOURS

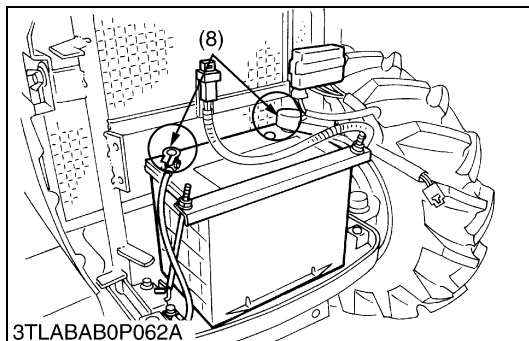
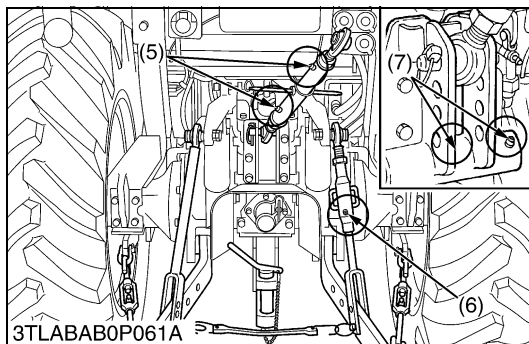
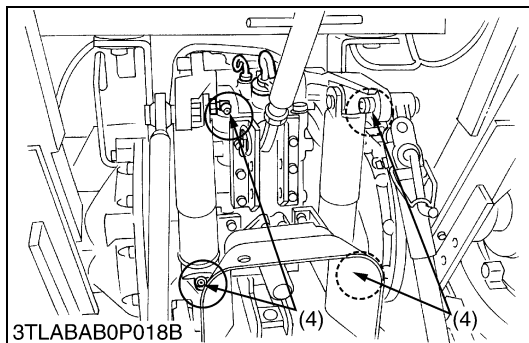
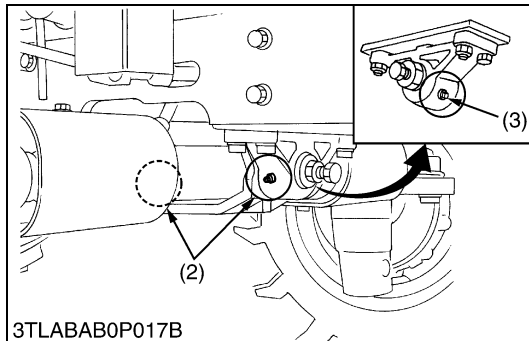
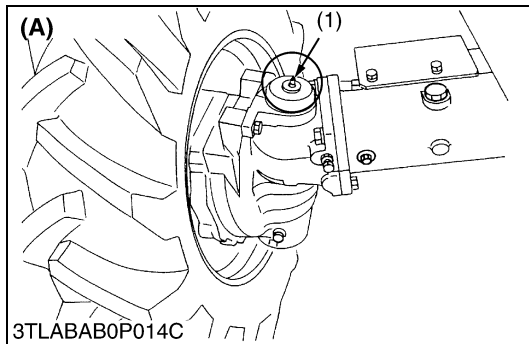

#### Greasing

1. Apply a grease to the following position as figures.

#### ■ NOTE

- Apply a small amount of multipurpose grease to the following points every 50 hours.  
If you operated the machine in extremely wet and muddy conditions, lubricate grease fittings more often.
- When apply a grease to the front axle support, remove the breather plug and apply a grease until grease overflows from breather plug. After greasing reinstall the plug.

- |  |                                      |
|--|--------------------------------------|
| (1) Grease Fitting (Front Wheel Case Support RH, LH) | (6) Grease Fitting (Lifting Rod RH)  |
| (2) Grease Fitting (Front Axle Support)              | (7) Grease Fitting (Toplink Bracket) |
| (3) Breather Plug                                    | (8) Battery Terminal                 |
| (4) Grease Fitting (Lift Cylinder)                   |                                      |
| (5) Grease Fitting (Top Link)                        |                                      |
- (A) L5030

W10308650



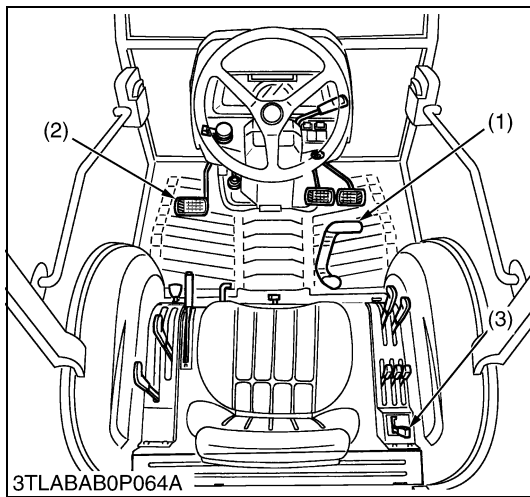

**Checking Engine Start System (HST Type)**

1. Place all control levers in the “NEUTRAL” position.
2. Set the parking brake and stop the engine.

■ **Test 1 : Switch for the speed control lever.**

1. Sit on operator’s seat.
2. Depress the speed control pedal to the desired direction.
3. Depress the clutch pedal fully.
4. Disengage the PTO clutch control lever.
5. Turn the key to “START” position.
6. The engine must not crank.

■ **Test 2 : Switch for the PTO clutch control lever.**

1. Sit on operator’s seat.
2. Engage the PTO clutch control lever.
3. Depress the clutch pedal fully.
4. Place the speed control pedal to the neutral position.
5. Turn the key to “START” position.
6. The engine must not crank.

■ **Test 3 : Switch for the clutch pedal.**

1. Sit on operator’s seat.
2. Disengage the PTO clutch control lever.
3. Place the speed control pedal to the neutral position.
4. Release the clutch pedal.
5. Turn the key to “START” position.
6. The engine must not crank.

■ **If it cranks at the test 1, 2 or 3, adjust or replace the required safety switch.**

- (1) Speed Control Pedal  
(2) Clutch Pedal

- (3) PTO Clutch Control Lever

W10739440

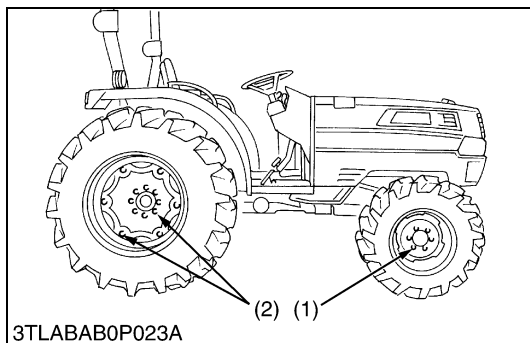

**Checking Wheel Mounting Screws and Nuts Tightening Torque**

**CAUTION**

- **Never operate tractor with a loose rim, wheel, or axle.**
1. Check wheel screws and nuts regularly especially when new. If there are loosened, tighten as follows.

Tightening torque	Front wheel mounting nuts	137 N·m 14 kgf·m 100 ft·lbs
	Rear wheel mounting screws and nuts	215 N·m 22 kgf·m 166 ft·lbs

- (1) Front Wheel Mounting Nut

- (2) Rear Wheel Mounting Screw and Nut

W1030725

## [4] CHECK POINTS OF EVERY 100 HOURS

### Changing Engine Oil

1. See page G-15.

W10320350

### Adjusting Brake Pedal

1. See page G-18.

W1075566

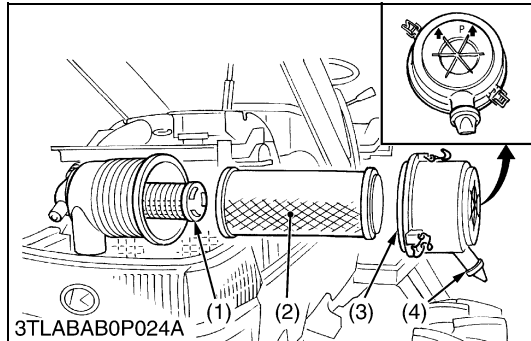

### Cleaning Air Cleaner Primary Element

1. Remove the air cleaner cover and primary element.
2. Clean the primary element :
  - When dry dust adheres to the element, blow compressed air from the inside turning the element. Pressure of compressed air must be under 205 kPa (2.1 kgf/cm<sup>2</sup>, 30 psi).
  - When carbon or oil adheres to the element, soak the element in detergent for 15 minutes then wash it several times in water, rinse with clean water and dry it naturally. After element is fully dried, inspect inside of the element with a light and check if it is damaged or not.
3. Replace air cleaner primary element :  
Once yearly or after every six times of cleaning, whichever comes first.

#### ■ NOTE

- Check to see if the evacuator valve is blocked with dust.

#### ■ IMPORTANT

- The air cleaner uses a dry element, never apply oil.
- Do not run the engine with filter element removed.
- Be sure to refit the cover with the arrow ↑ (on the rear of cover) upright. If the cover is improperly fitted, evacuator valve will not function and dust will adhere to the element.
- Do not touch the secondary element except in cases where replacing is required.

See "Replacing Air Cleaner Secondary Element" in Every 1 Year section. (See page G-32.)

#### ■ Evacuator Valve

Open the evacuator valve (4) once a week under ordinary conditions or daily when used in a dusty place to get rid of large particles of dust and dirt.

- (1) Secondary (Safety) Element  
(2) Primary Element

- (3) Cover  
(4) Evacuator Valve

W1076669

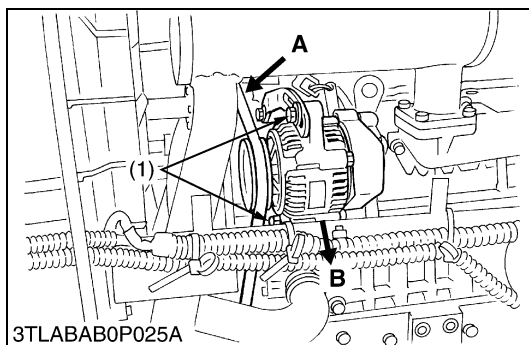
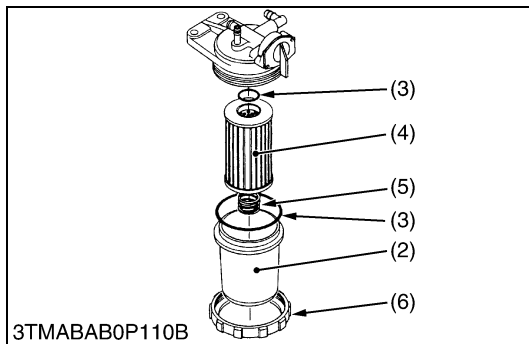
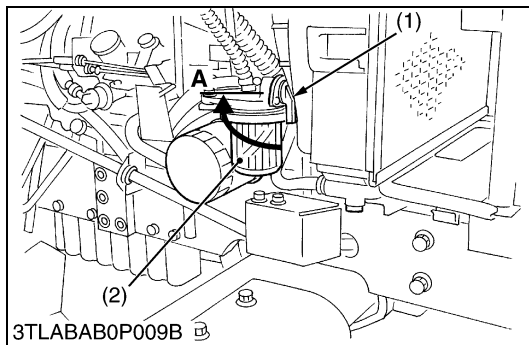

### Cleaning Fuel Filter

This job should not be done in the field, but in a clean place.

1. Close the fuel filter cock (1).
2. Unscrew the screw ring and remove the fuel filter bowl (2), and rinse the inside with kerosene.
3. Take out the filter element (4) and dip it in the kerosene to rinse.
4. After cleaning, reassemble the fuel filter, keeping out dust and dirt.
5. Bleed the fuel system. (See page G-34.)

#### ■ IMPORTANT

- If dust and dirt enters the fuel system the fuel pump and injection nozzles are subject to premature wear. To prevent this, be sure to clean the fuel filter and element bowl periodically.

- |                      |                    |
|----------------------|--------------------|
| (1) Fuel Cock        | (4) Filter Element |
| (2) Fuel Filter Bowl | (5) Spring         |
| (3) O-ring           | (6) Screw Ring     |
| <b>A : Close</b>     |                    |

W1078193

### Adjusting Fan Belt Tension

#### ⚠ CAUTION

- Be sure to stop the engine before checking fan belt tension.
1. Stop the engine and remove the key.
  2. Apply moderate thumb pressure to belt between pulleys.
  3. If tension is incorrect, loosen the alternator mounting bolts and using a lever placed between the alternator and the engine block, pull the alternator out until the deflection of the belt falls within the factory specifications.
  4. Replace fan belt if it is damaged.

Fan belt tension	Factory spec.	A deflection of between 7 to 9 mm (0.28 to 0.34 in.) when the belt is pressed in the middle of the span.
------------------	---------------	--

- (1) Alternator Mounting Bolt

**A : Check the belt tension**  
**B : To Tighten**

W10326270



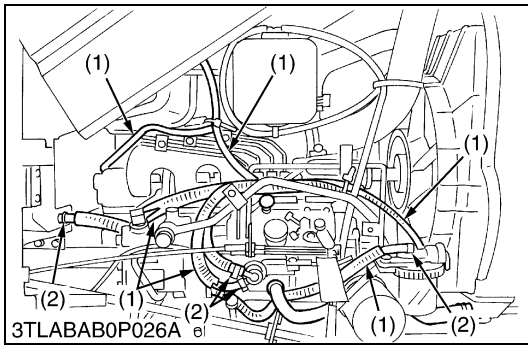

### Checking Fuel Line

#### ⚠ CAUTION

- Stop the engine when attempting the check and change prescribed below.
- Remember to check the fuel line periodically. The fuel line is subject to wear and aging, fuel may leak out onto the running engine, causing a fire.

1. Check to see that all line and hose clamp are tight and not damaged.
2. If hoses and clamps are found worn or damaged, replace or repair them at once.
3. The fuel line is made of rubber and ages regardless of period of service. Replace the fuel pipe together with the clamp every two years and securely tighten.
4. However if the fuel pipe and clamp are found damaged or deteriorated earlier than two years, then change or remedy.
5. After the fuel line and clamp have been changed, bleed the fuel system.

#### ■ IMPORTANT

- When the fuel line is disconnected for change, close both ends of the fuel line with a piece of clean cloth or paper to prevent dust and dirt from entering. Entrance of dust and dirt causes malfunction of the fuel injection pump. In addition, particular care must be taken not to admit dust and dirt into the fuel pump.

(1) Fuel Hose

(2) Clamp

W10342570

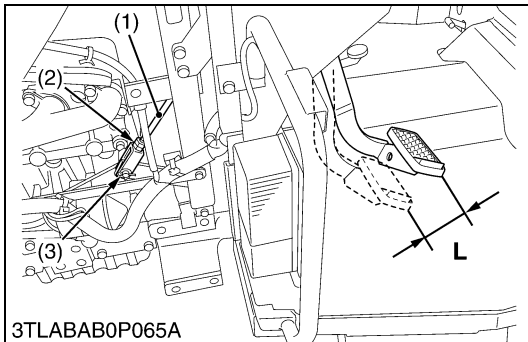

### Adjusting Clutch Pedal Free Travel

#### ⚠ CAUTION

- When checking, park the tractor on flat ground, apply the parking brake, stop the engine and remove the key.

1. Slightly depress the clutch pedal and measure free travel "L" at top of clutch pedal.
2. If the measurement is not within the factory specifications, loosen the lock nut (2), remove the clevis pin (3) adjust the length of rod (1) within acceptable limits.
3. Retighten the lock nut (2) and split the cotter pin.

Clutch pedal free travel "L" on top of clutch pedal	Factory spec.	20 to 30 mm 0.78 to 1.18 in.
---	---------------	---------------------------------

(1) Clutch pedal Rod

L : Free Travel

(2) Lock Nut

(3) Clevis Pin

W1032993



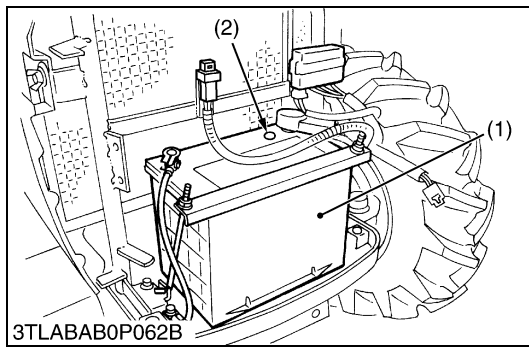

## Checking Battery Condition

To avoid the possibility of battery explosion:

For the refillable type battery, follow the instructions below.

- Do not use or charge the refillable type battery if the fluid level is below the LOWER (lower limit level) mark.

Otherwise, the battery component parts may prematurely deteriorate, which may shorten the battery's service life or cause an explosion. Check the fluid level regularly and add distilled water as required so that the fluid level is between the UPPER and LOWER levels.

### ⚠ CAUTION

- Never remove the vent plugs while the engine is running.
- Keep electrolyte away from eyes, hands and clothes. If you are splattered with it, wash it away completely with water immediately and get medical attention.
- Wear eye protection and rubber gloves when working around battery.

### ■ NOTE

- The factory-installed battery is of non-refillable type. If the indicator turns white, do not charge the battery but replace it with new one.

1. Mishandling the battery shortens the service life and adds to maintenance costs.

2. The original battery is maintenance free type battery, but need some servicing.

If the battery is weak, the engine is difficult to start and the lights be dim. It is important check the battery periodically.

3. Check the battery condition by reading the indicator.

State of indicator display.

Green: Specify gravity of electrolyte and quality of electrolyte are both in good condition.

Black: Need charging battery.

White: Need charging battery.

(1) Battery

(2) Indicator

W1095602

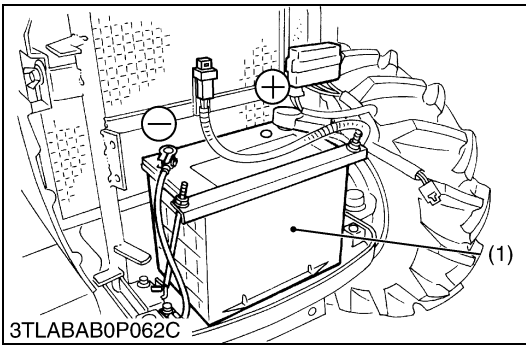

## ■ Battery Charging

### ⚠ CAUTION

- When the battery is being activated, hydrogen and oxygen gases in the battery are extremely explosive. Keep open sparks and flames away from the battery at all times, especially when charging the battery.
- When charging battery, remove battery vent plugs.
- When disconnecting the cable from the battery, start with the negative terminal first.  
When connecting the cable to the battery, start with the positive terminal first.
- Never check battery charge by placing a metal object across the posts.

**Use a voltmeter or hydrometer.**

1. To slow charge the battery, connect the battery positive terminal to the charger positive terminal and the negative to the negative, then recharge in the standard fashion.
2. A boost charge is only for emergencies. It will partially charge the battery at a high rate and in a short time.  
When using a boost-charged battery, it is necessary to recharge the battery as early as possible.  
Failure to do this will shorten the battery's service life.
3. The battery is charged if the indicator display turns green from black.
4. When exchanging an old battery into new one, use battery of equal specification shown in table 1.

**Table 1**

Tractor model	Battery Type	Volt (V)	Capacity at 5 H.R. (A.H.)	Reserve Capacity (min.)	Cold Cranking Amps	Normal Charging Rate (A)
L3130 L3430	75D26R	12	52	123	490	6.5
L3830 L4630 L5030	80D26R	12	55	133	582	6.5

### ■ Direction for Storage

1. When storing the tractor for long periods of time, remove the battery from tractor, adjust the electrolyte to the proper level and store in a dry place out of direct sunlight.
2. The battery self-discharges while it is stored.  
Recharge it once every three months in hot seasons and once every six months in cold seasons.

(1) Battery

W1033925

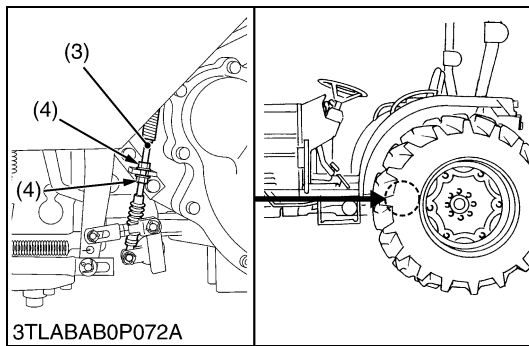
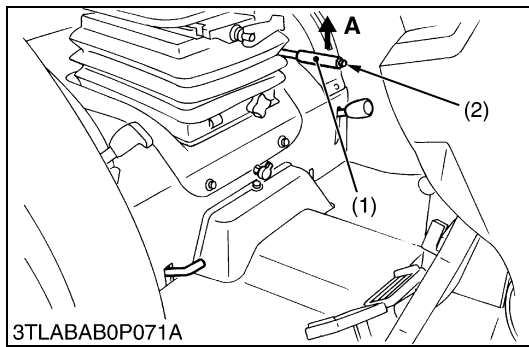

### Adjusting Parking Brake Lever

#### ⚠ CAUTION

- Stop the engine and chock the wheels before checking parking brake.

1. Raise the parking brake lever (1) to the parking position while counting the ratchet sound made by the parking brake lever (1).
2. If adjustment is needed, loosen the lock nut (2) and adjust the parking brake cable (3) length with in acceptable limit.
3. Retighten the lock nut (2).

Proper parking brake lever free travel	Factory spec.	2 notches (Ratchet sound 2)
--	---------------	-----------------------------

- |                         |                         |
|-------------------------|-------------------------|
| (1) Parking Brake Lever | (3) Parking Brake Cable |
| (2) Release Button      | (4) Lock Nut            |

W1073621

## [5] CHECK POINTS OF EVERY 200 HOURS

### Replacing Engine Oil Filter Cartridge

1. See page G-15.

W10344210

### Replacing Hydraulic Oil Filter / Replacing Transmission Oil Filter [HST Type]

1. See page G-16.

W10344720

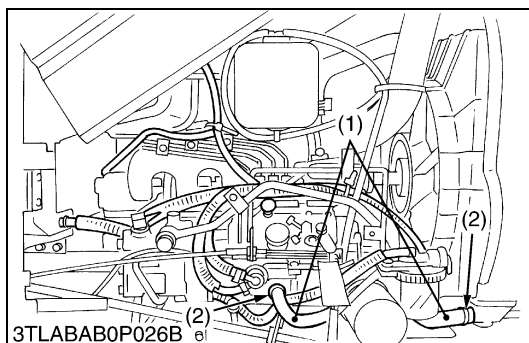
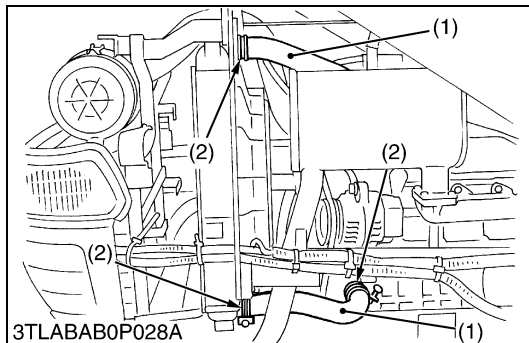

### Checking Radiator Hose and Hose Clamp

Check to see if radiator hoses are properly fixed every 200 hours of operation or six months, whichever comes first.

1. If hose clamps are loose or water leaks, tighten bands securely.
2. Replace hoses and tighten hose clamps securely, if radiator hoses are swollen, hardened or cracked.

Replace hoses and hose clamps every 2 years or earlier if checked and found that hoses are swollen, hardened or cracked.

#### ■ Precaution at Overheating

Take the following actions in the event the coolant temperature be nearly or more than the boiling point, what is called "Overheating".

1. Stop the machine operation in a safe place and keep the engine unloaded idling.
2. Don't stop the engine suddenly, but stop it after about 5 minutes of unloaded idling.
3. Keep yourself well away from the machine for further 10 minutes or while the steam blown out.
4. Checking that there gets no danger such as burn, get rid of the causes of overheating according to the manual, see "Troubleshooting" section, and then, start again the engine.

- |                   |           |
|-------------------|-----------|
| (1) Radiator Hose | (2) Clamp |
|-------------------|-----------|

W10347370

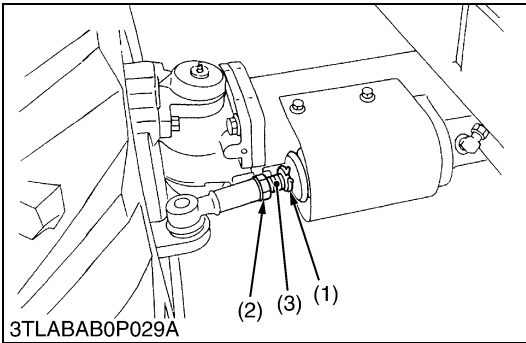
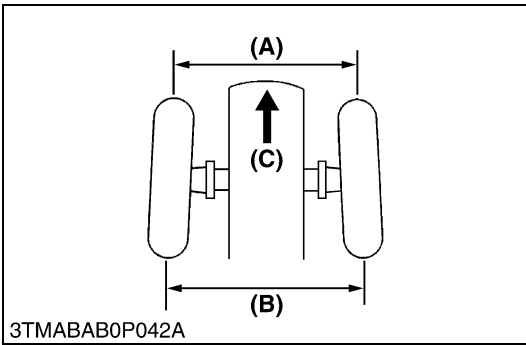

### Adjusting Toe-in

1. Park the tractor on the flat place.
2. Inflate the tires to the specified pressure.
3. Turn steering wheel so front wheels are in the straight ahead position.
4. Lower the implement, lock the parking brake and stop the engine.
5. Measure distance between tire beads at front of tire, hub height.
6. Measure distance between tire beads at rear of tire, hub height.
7. Front distance should be 2 to 8 mm (0.079 to 0.315 in.) less than rear distance.
8. If the measurement is not within the factory specifications, adjust by changing the tie-rod length.

Toe-in (B - A)	Factory spec.	2 to 8 mm 0.079 to 0.315 in.
----------------	---------------	---------------------------------

### Adjusting

1. Detach the snap ring (1).
2. Loosen the tie-rod nut (2) and turn the tie-rod joint (3) to adjust the tie-rod length until the proper toe-in measurement is obtained.
3. Retighten the tie-rod nut (2).
4. Attach the snap ring (1) of the tie-rod joint.

Tightening torque	Tie-rod lock nut	166.7 to 196.1 N·m 17.0 to 20.0 kgf·m 123 to 145 ft-lbs
-------------------	------------------	---

### IMPORTANT

- A right and left tie-rod joint is adjusted to the same length.

- (1) Snap Ring  
(2) Tie-rod Nut  
(3) Tie-rod Joint

- (A) Wheel to Wheel Distance at front  
(B) Wheel to Wheel Distance at rear  
(C) Front

W1082751

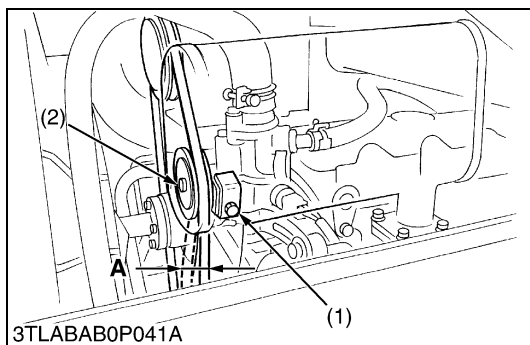
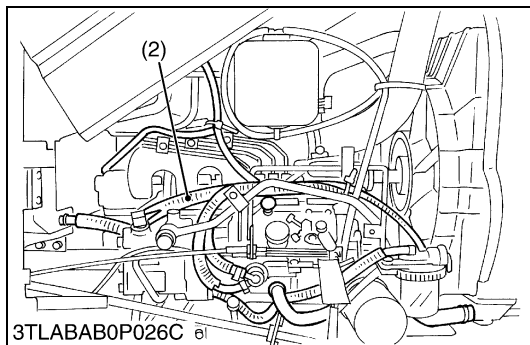
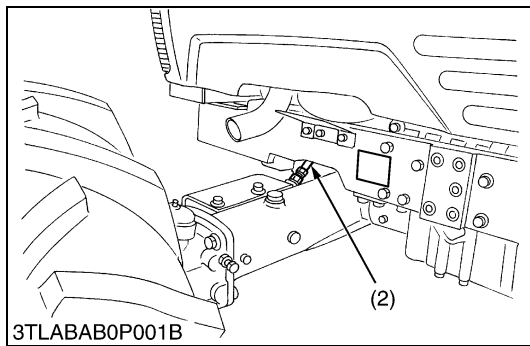
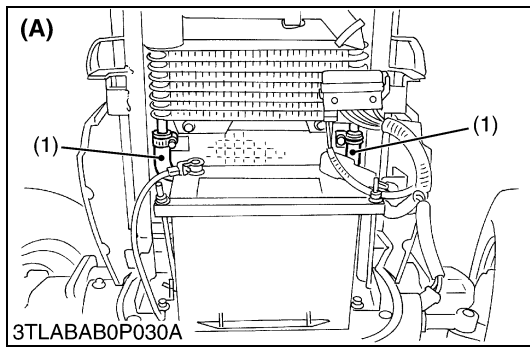

**Checking HST Oil Line [HST Type] / Checking Power Steering Line**

1. Check to see that all lines and hose clamps are tight and not damaged.
2. If hoses and clamps are found worn or damaged, replace repair them at once.

- (1) HST Oil Line
- (2) Power Steering Pressure Hoses

(A) HST Type

W1085565

**Adjusting Air Conditioner Belt Tension (Cabin Model)**

**⚠ CAUTION**

- Be sure to stop the engine before checking air conditioner belt tension.

1. Stop the engine and remove the key.
2. Apply 98 N (10 kgf, 22 lbs) pressure to the belt between the pulleys.
3. If tension is incorrect, adjust the belt tension.
4. If belt is damaged, replace it.

Air conditioner belt tension	Factory spec.	A deflection of between 10 to 12 mm (0.39 to 0.47 in.) when the belt is pressed in the middle of the span
------------------------------	---------------	---

- (1) Adjusting Bolt
- (2) Nut

A : Deflection

W1019789

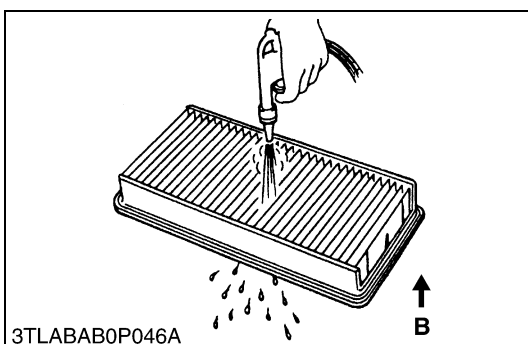
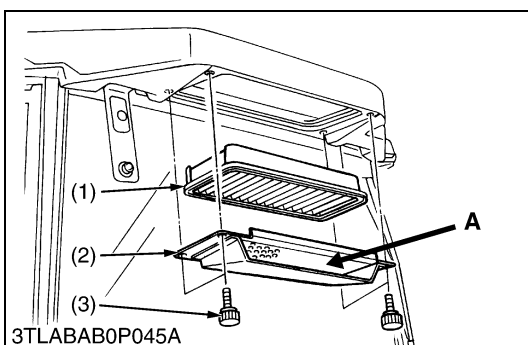
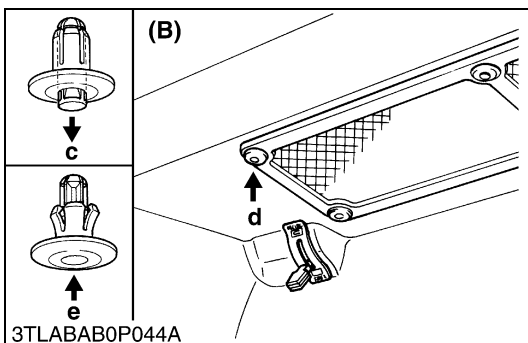
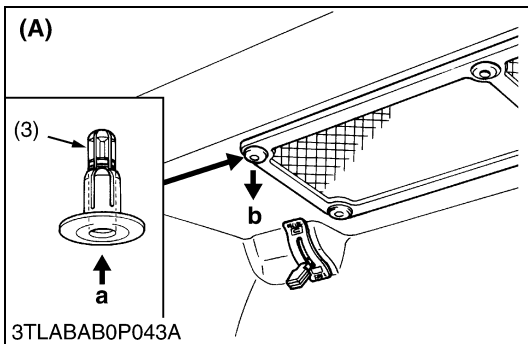
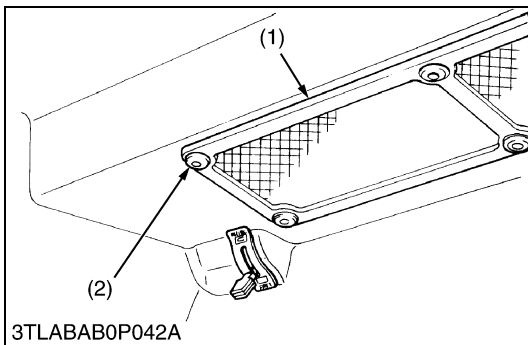

### Cleaning Inner Air Filter (Cabin Model)

1. Remove the inner filter, and blow air from the direction opposite to the filter's normal air flow.

#### (Reference)

- Detach and attach the push-rivet (2) as follows.
  - Detaching procedure (A)
    - Push in the center rivet (a) and pull out the push-rivet assembly (b).
  - Attaching procedure (B)
    - Pull out the center rivet (c), attach the push-rivet assembly (d) and push up the center-rivet (e).

- (1) Inner Air Filter  
 (2) Push-rivet  
 (3) Center-rivet

- a : Push in center-rivet  
 b : Pull out push-rivet assembly  
 c : Pull out center-rivet  
 d : Attach push-rivet assembly  
 e : Push up center-rivet

W1118812

### Cleaning Air Filter (Cabin Model)

#### ■ Fresh Air Filter

1. Remove the knob bolts (3) and pull out the fresh air filter (1).
2. Blow air from the opposite direction to the filter's normal air flow.

#### ■ NOTE

- If the filter is very dirty :
  - Dip the filter in lukewarm water with mild dish washing detergent.
  - Move it up and down as well as left and right to loosen dirt.
  - Rinse the filter with clean water and let it air-dry.

#### ■ IMPORTANT

- Do not use gasoline, thinner or similar chemicals to clean the filter as damage to the filter may occur.
- If may also cause an unpleasant odor in the CABIN when the system is used next.
- Do not hit the filter. If the filter becomes deformed, dust may enter into the air-conditioner, which may cause damage and malfunction.

- (1) Fresh Air Filter  
 (2) Cover  
 (3) Knob Bolt

- A : Air Inlet Port  
 B : Air Conditioner Air Flow

W1019336

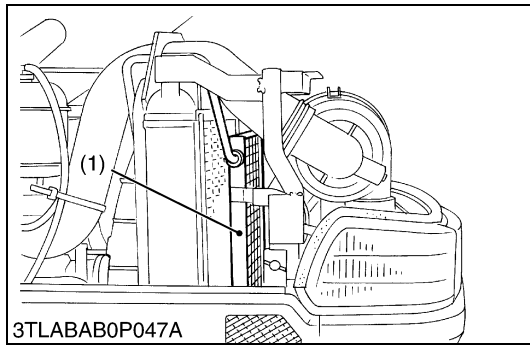

### Checking Air Conditioner Condenser (Cabin Model)

1. Check the air conditioner condenser (1).
2. If dust and dirt, wash off all dirt and dust from the condenser (1) with a soft brush, use care not to damage or bend the fins.

(1) Air Conditioner Condenser

W1019699

## [6] CHECK POINTS OF EVERY 400 HOURS

### Changing Transmission Fluid

1. See page G-17.

W10365120

### Changing Front Axle Case Oil

1. See page G-18.

W10365590

### Replacing Fuel Filter Element

1. See page G-23.

W1085936

## [7] CHECK POINTS OF EVERY 600 HOURS

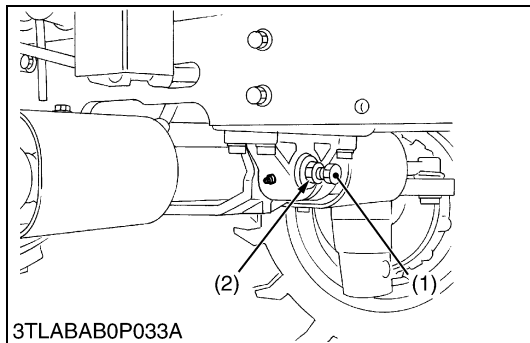

### Adjust Front Axle Pivot

1. Loosen the lock nut (2), tighten the adjusting screw (1) all the way, and then loosen the adjusting screw (1) by 1/6 turn.
2. Retighten the lock nut (2).

#### ■ NOTE

- If the axle pivot pin adjustment is not correct, front wheel vibration can occur causing vibration in the steering wheel.

#### (Reference)

Tightening torque	Front axle adjusting screw	19.6 to 29.4 N·m 2.0 to 3.0 kgf·m 14.5 to 21.7 ft·lbs
	Lock nut	98.1 to 147.1 N·m 10.0 to 15.0 kgf·m 72.3 to 108.5 ft·lbs

(1) Adjusting Screw

(2) Lock Nut

W1036668

## [8] CHECK POINTS OF EVERY 800 HOURS

### Checking Valve Clearance

1. See page 1-S27.

W1036805



## [9] CHECK POINTS OF EVERY 1 YEAR

### Replacing Air Cleaner Primary Element and Secondary Element

1. Replace the both primary and secondary elements.  
Refer to “**Cleaning Air Cleaner Primary Element**”. (See page G-22.)

W1037077

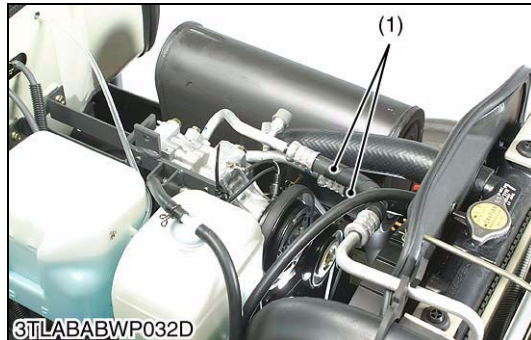

3TLABABWP032D

### Checking Air Conditioner Pipe and Hose

1. Check to see that all lines and hose clamps are tight and not damaged.
2. If hoses (1) and clamps are found worn or damaged, replace or repair them at once.

(1) Hose

W1021331

### Checking Cabin Isolation Cushion

1. Check the isolation cushion (1) for any breakage or fatigue.
2. Replace them if they have deteriorated.

(1) Isolation Cushion

F : Front Side

R : Rear Side

W1021413

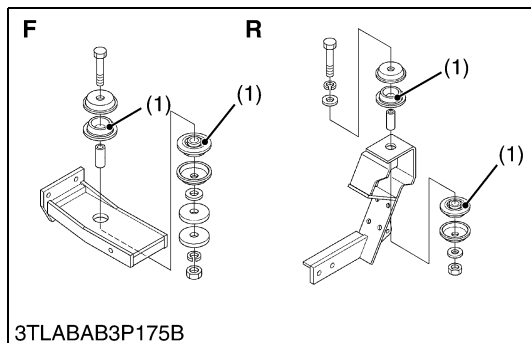

3TLABAB3P175B

## [10] CHECK POINTS OF EVERY 2 YEARS

### Replacing Fuel Hose

1. Replace the fuel hoses and clamps, if necessary.  
Refer to “**Checking Fuel Line**”. (See page G-24.)

W1037148

### Replacing Parking Brake Cable

1. Replace the cable.  
Refer to “**Adjusting Parking Brake Lever**”. (See page G-27.)

W1037203

### Replacing HST Oil Line

1. Replace the hoses and clamps.  
Refer to “**Checking HST Oil Line and Power Steering Line**”.  
(See page G-29.)

W1037296

### Replacing Power Steering Hose

1. Replace the hoses and clamps.  
Refer to “**Checking HST Oil Line and Power Steering Line**”.  
(See page G-29.)

W1037361

### Replacing Radiator Hose (Water Pipes)

1. Replace the hoses and clamps.  
Refer to “**Checking Radiator Hose and Hose Clamp**”. (See page G-27.)

W1037429



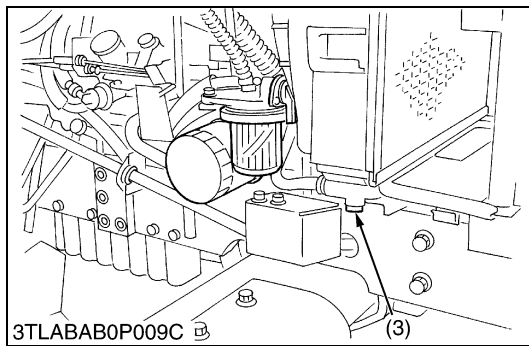
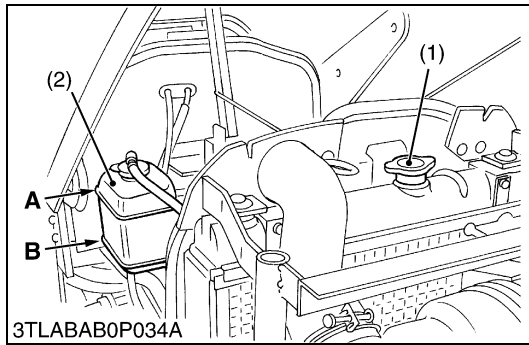

### Flushing Cooling System and Changing Coolant

#### ⚠ CAUTION

- Do not remove the radiator cap when the engine is hot. Then loosen cap slightly to the stop to relieve any excess pressure before removing cap completely.

1. Stop the engine and let cool down.
2. To drain the coolant, open the radiator drain plug (3) and remove the radiator cap (1). The radiator cap (1) must be removed to completely drain the coolant.
3. After all coolant is drained, close the drain plug (3).
4. Fill with clean water and cooling system cleaner.
5. Follow directions of the cleaner instruction.
6. After flushing, fill with clean water and anti-freeze until the coolant level is just below the port. Install the radiator cap (1) securely.
7. Fill with coolant up to “FULL” mark on the recovery tank.
8. Start and operate the engine for few minutes.
9. Stop the engine and let cool. Check coolant level of recovery tank (2) and add coolant if necessary.

#### ■ IMPORTANT

- Do not start engine without coolant.
- Use clean, fresh water and anti-freeze to fill the radiator and recovery tank.
- When the anti-freeze is mixed with water, the anti-freeze mixing ratio must be less than 50 %.
- Securely tighten radiator cap. If the cap is loose or improperly fitted, water may leak out and the engine could overheat.
- Refer to “LUBRICANTS, FUEL AND COOLANT”. (See page G-7, 8.)

Coolant capacity (with recovery tank)	L3130 L3430	6.0 L 6.3 U.S.qts 5.3 Imp.qts
	L3830 (ROPS) L4630 (ROPS)	7.5 L 7.9 U.S.qts 6.6 Imp.qts
	L3830 (CABIN) L4630 (CABIN)	8.7 L 9.2 U.S.qts 7.7 Imp.qts
	L5030	9.2 L 9.7 U.S.qts 8.1 Imp.qts

- (1) Radiator Cap  
(2) Recovery Tank  
(3) Drain Plug

**A : FULL**  
**B : LOW**

W1037510

**Flushing Cooling System and Changing Coolant (Continued)****■ Anti-Freeze**

If coolant freezes, it can damage the cylinders and radiator. It is necessary, if the ambient temperature falls below 0 °C (32 °F), to remove coolant after operating or to add anti-freeze to it.

1. There are two types of anti-freeze available ; use the permanent type (PT) for this engine.
2. Before adding anti-freeze for the first time, clean the radiator interior by pouring fresh water and draining it a few times.
3. The procedure for mixing of water and anti-freeze differs according to the make of the anti-freeze and the ambient temperature, basically it should be referred to SAE J1034 standard, more specifically also to SAE J814c.
4. Mix the anti-freeze with water, and then fill in to the radiator.

Vol % Anti-freeze	Freeze Point		Boiling Point*	
	°C	°F	°C	°F
40	-24	-12	106	222
50	-37	-34	108	226

\*At 760 mmHg pressure (atmospheric). A higher boiling point is obtained by using a radiator pressure cap which permits the development of pressure within the cooling system.

**■ NOTE**

- The above data represent industry standards that necessitate a minimum glycol content in the concentrated anti-freeze.
- When the coolant level drops due to evaporation, add water only. In case of leakage, add anti-freeze and water in the specified mixing ratio.
- Anti-freeze absorbs moisture. Keep unused anti-freeze in a tightly sealed container.
- Do not use radiator cleaning agents when anti-freeze has been added to the coolant. (Anti-freeze contains an anti-corrosive agent, which will react with the radiator cleaning agent forming sludge which will affect the engine parts.)

W10385910

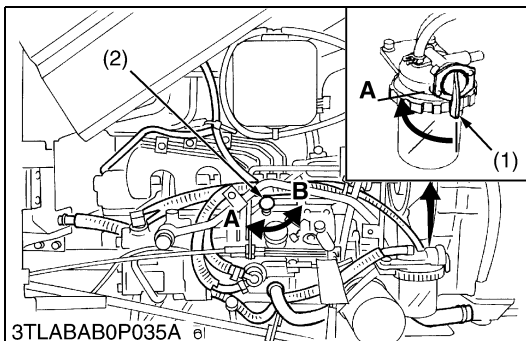
**[11] OTHERS****Bleeding Fuel System**

Air must be removed :

1. When the fuel filter or lines are removed.
2. When tank is completely empty.
3. After the tractor has not been used for a long period of time.

Bleeding procedure is as follows.

1. Fill the fuel tank with fuel, and open the fuel cock (1).
2. Open the air vent cock (2) on the fuel injection pump.
3. Start the engine and run for about 30 seconds, and then stop the engine.
4. Close the air vent cock.

**■ IMPORTANT**

- Always close the air vent cock except for bleeding fuel lines. Otherwise, engine runs irregularly or stalls frequently.

- (1) Fuel Cock  
(2) Air Vent Cock

- A : Close  
B : Open

W1039026

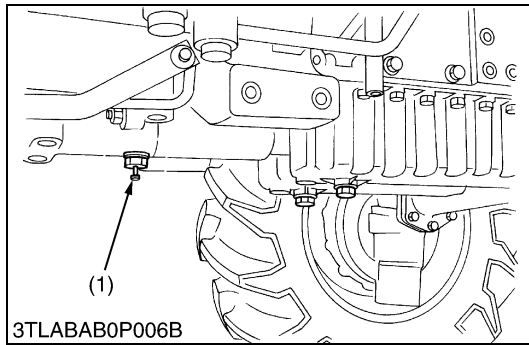

### Draining Clutch Housing Water

#### ■ NOTE

- The tractor is equipped with split pin plug (1) under the clutch housing.
- After operating in rain, snow or tractor has been washed, water may get into the clutch housing.

1. Check it by pushing in the split pin (1).
2. If water enters into the clutch housing, remove the plug (1) and drain the water, then reinstall the plug.

(1) Split Pin (Plug)

W1039199

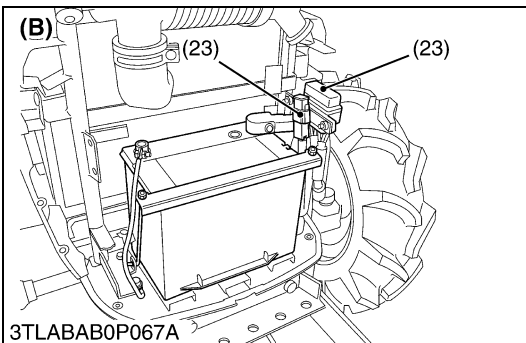
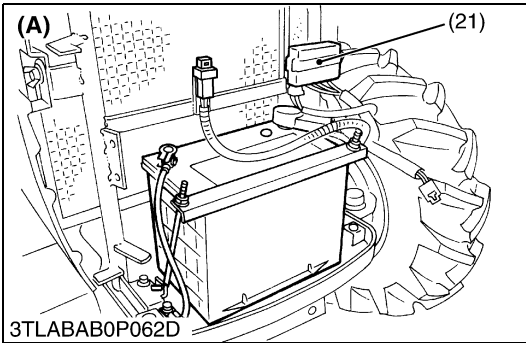
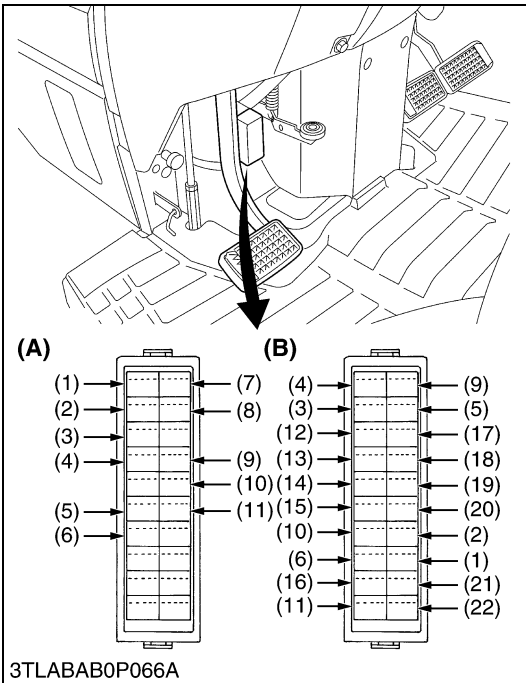

### Replacing Fuse

1. The tractor electrical system is protected from potential damage by fuses.  
A blown fuse indicates that there is an overload or short somewhere in the electrical system.
2. If any of the fuses should blow, replace with a new one of the same capacity.

#### ■ IMPORTANT

- Before replacing a blown fuse, determine why the fuse blew and make any necessary repairs. Failure to follow this procedure may result in serious damage to the tractor electrical system. Refer to troubleshooting section of this manual.

If any of them should blow, replace with a new one of the same capacity.

#### ■ Protected Circuit

Fuse No.	Capacity (A)	Protected circuit	ROPS	CABIN
1	25	Head lights	☆	☆
2	20	Flasher	☆	☆
3	20	Hazard	☆	☆
4	5	Panel	☆	☆
5	7.5	Alternator	☆	☆
6	5	Lamp relay	☆	☆
7	7.5	Work light	☆	—
8	5	Brake lamp switch	☆	—
9	5	Key stop	☆	☆
10	30	Starter relay	☆	☆
11	7.5	Position lamp	☆	—
12	5	T/M controller 1 (GST Type)	—	☆
13	10	Dome lamp	—	☆
14	15	Aircon blower	—	☆
15	10	Radio cassette	—	☆
16	10	Patrol lamp	—	—
17	10	T/M controller 2 (GST Type)	—	☆
18	20	Cigar lighter	—	☆
19	7.5	Aircon compressor	—	☆
20	30	Wiper	—	☆
21	15	Work light	—	☆
22	30	Defogger	—	☆
23	Slow blow fuse	Check circuit against wrong battery connection.	☆	☆

(A) ROPS Model

(B) CABIN Model

W1039315

**Replacing Light Bulb**

1. Head lights and rear combination lights :  
Take the bulb out of the light body and replace with a new one.
2. Other lights :  
Detach the lens and replace the bulb.

Light	Capacity	
	ROPS	CABIN
Head lights	45 W / 40 W	
Tail light	10 W	
Hazard and turn signal light (rear)	21 W	
Hazard and turn signal light (front)	21 W	
Side marker light	5 W	
Room light	–	10 W
Work light	–	27 W
Instrument panel light	1.1 W	
Brake stop light	21 W	
Number plate light	10 W	

W1039659

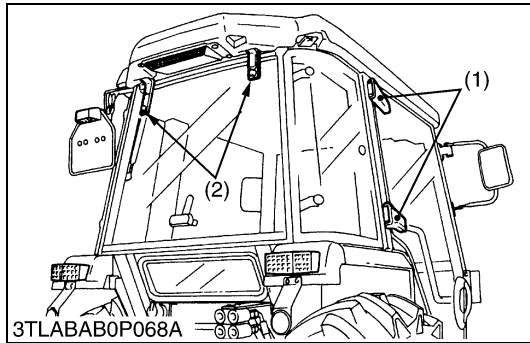

**Lubricating Points**

- (1) Door Hinge
- (2) Rear Window Hinge

W1120093

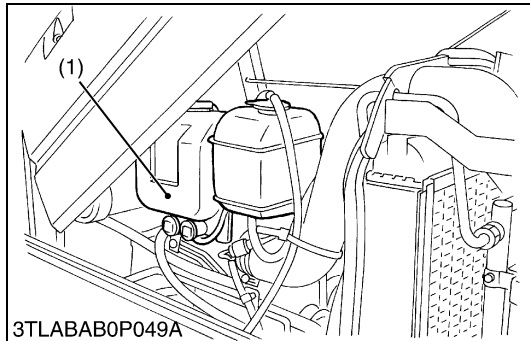

**Adding Washer Liquid**

1. Add a proper amount of automobile washer liquid.

Tank capacity	2.0 L 0.53 U.S.gals 0.44 Imp.gals
---------------	---

- (1) Washer Liquid Tank

W1120170

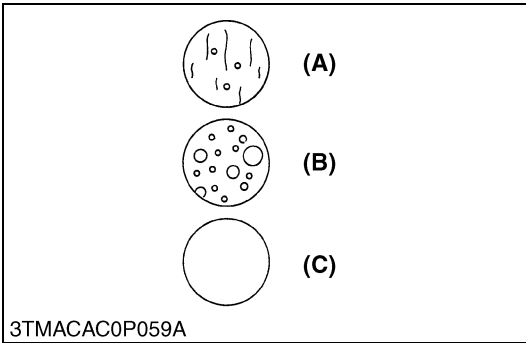
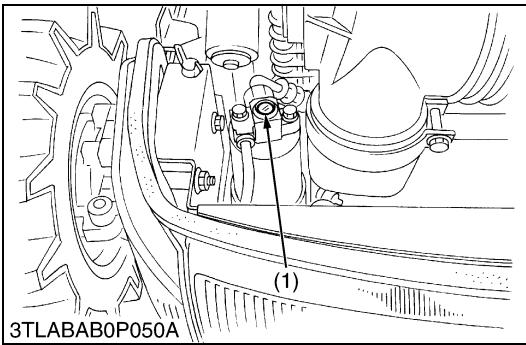

### Checking Refrigerant (Gas)

#### ⚠ CAUTION

- Liquid contact with eyes or skin may cause frostbite.
- In the event of a leakage, wear safety goggles. Escaping refrigerant can cause severe injuries to eyes.
- In contact with a flame, R134a refrigerant gives a toxic gas.
- Do not disconnect any part of the refrigeration circuit of the air conditioning system.

A shortage of refrigerant impairs the air-conditioner performance. Check the following points. If it is indicated that the amount of refrigerant is extremely low, inspect and charge. (See page 10-S21.)

#### ■ Checking Procedure

1. Run the air-conditioner in the following conditions.
  - Engine speed : About 1500 min<sup>-1</sup> (rpm)
  - Temperature control lever : Maximum cooling position (leftmost)
  - Fan switch : Highest blow (HI)
  - Air-conditioner switch : **ON**
2. Look into the sight glass (1) to see if the refrigerant is flowing through its circuit.

#### ■ IMPORTANT

- Charge only with R134a not R12 refrigerant (gas).

(1) Sight Glass

- (A) Proper : Little or no air bubbles in the refrigerant flow.
- (B) Low : Lots of air bubbles in the refrigerant flow (air bubbles or foam passing continuously).
- (C) Overfull or no refrigerant : Colorless and transparent.

W1120282

## 8. SPECIAL TOOLS

### [1] SPECIAL TOOLS FOR ENGINE

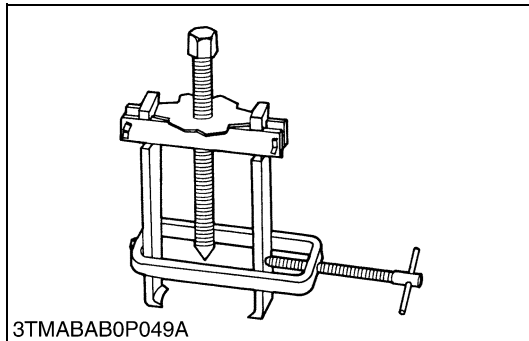

#### Special Use Puller Set

Code No.: 07916-09032

Application: Use exclusively for pulling out bearing, gears and other parts with ease.

W10240500

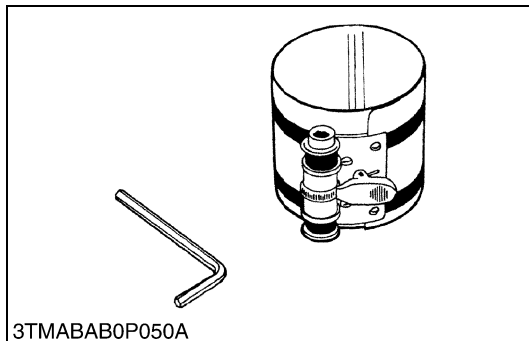

#### Piston Ring Compressor

Code No.: 07909-32111

Application: Use exclusively for pushing in the piston with piston rings into the cylinder.

W10241000

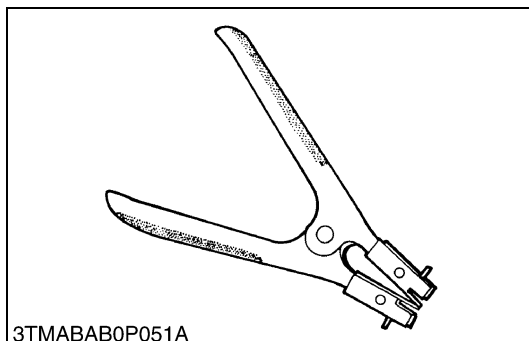

#### Piston Ring Tool

Code No.: 07909-32121

Application: Use exclusively for removing or installing the piston ring with ease.

W10241500

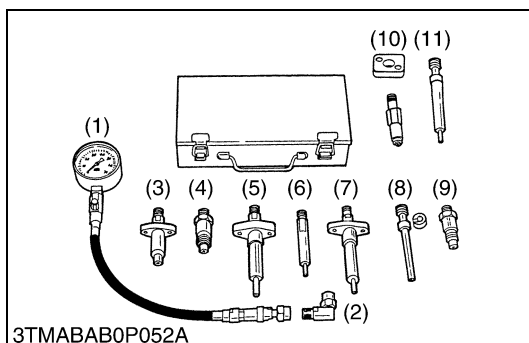

#### Diesel Engine Compression Tester

Code No.: 07909-30208 (Assembly) 07909-31251 (G)

07909-30934 (A to F) 07909-31271 (I)

07909-31211 (E and F) 07909-31281 (J)

07909-31231 (H)

Application: Use to measure diesel engine compression and diagnostics of need for major overhaul.

(1) Gauge  
 (2) L Joint  
 (3) Adaptor A  
 (4) Adaptor B  
 (5) Adaptor C  
 (6) Adaptor E

(7) Adaptor F  
 (8) Adaptor G  
 (9) Adaptor H  
 (10) Adaptor I  
 (11) Adaptor J

W10242000

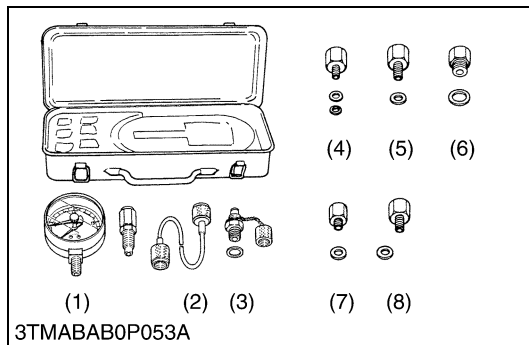
**Oil Pressure Tester**

Code No.: 07916-32032

Application: Use to measure lubricating oil pressure.

- |                    |               |
|--------------------|---------------|
| (1) Gauge          | (5) Adaptor 2 |
| (2) Cable          | (6) Adaptor 3 |
| (3) Threaded Joint | (7) Adaptor 4 |
| (4) Adaptor 1      | (8) Adaptor 5 |

W10243180

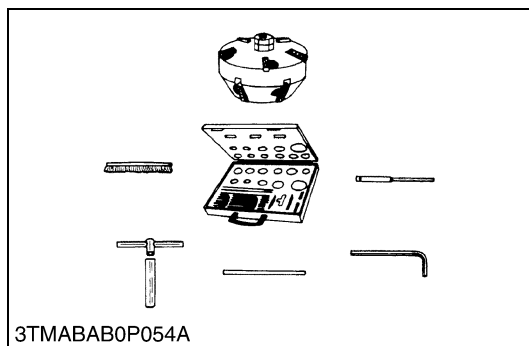
**Valve Seat Cutter**

Code No.: 07909-33102

Application: Use to reseal valves.

Angle: 0.785 rad (45°)

0.262 rad (15°)

Diameter: 28.6 mm (1.126 in.) 38.0 mm (1.496 in.)

31.6 mm (1.244 in.) 41.3 mm (1.626 in.)

35.0 mm (1.378 in.) 50.8 mm (2.000 in.)

W10244580

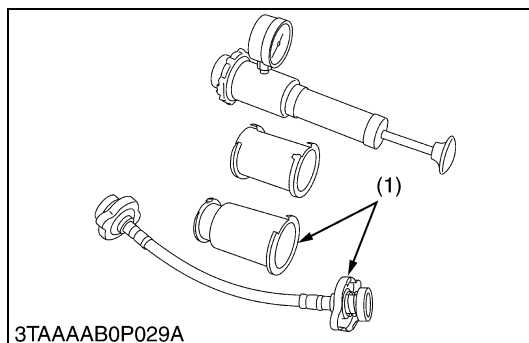
**Radiator Tester**

Code No.: 07909-31551

Application: Use to check of radiator cap pressure, and leaks from cooling system.

Remarks: Adapter (1) BANZAI Code No. RCT-2A-30S

W10245320

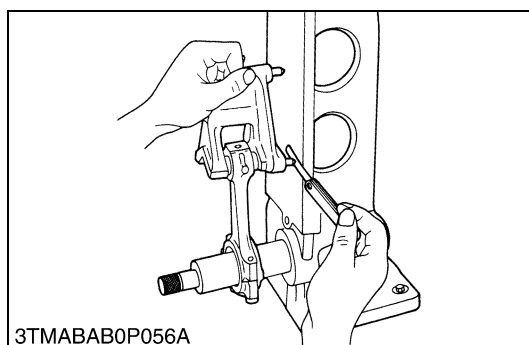
**Connecting Rod Alignment Tool**

Code No.: 07909-31661

Application: Use to check the connecting rod alignment.

Applicable: Connecting rod big end I.D.

range 30 to 75 mm (1.18 to 2.95 in.) dia.

Connecting rod length

65 to 300 mm (2.56 to 11.81 in.)

W10245830

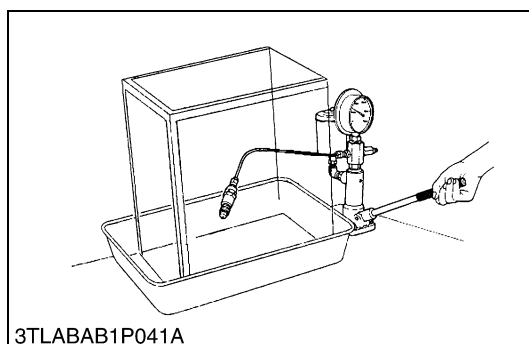
**Nozzle Tester**

Code No.: 07909-31361

Application: Use to check the fuel injection pressure and spray pattern of nozzle.

Measuring: 0 to 50 MPa

range (0 to 500 kgf/cm<sup>2</sup>, 0 to 7000 psi)

W10246530



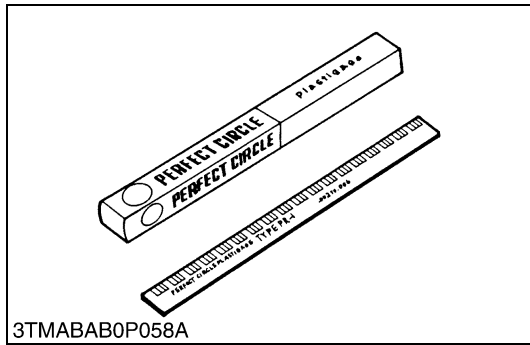

3TMABAB0P058A

**Plastigage**

Code No.: 07909-30241

Application: Use to check the oil clearance between crankshaft and bearing, etc.

Measuring: Green .... 0.025 to 0.076 mm (0.001 to 0.003 in.)  
 range Red ..... 0.051 to 0.152 mm (0.002 to 0.006 in.)  
 Blue ..... 0.102 to 0.229 mm (0.004 to 0.009 in.)

W10247190

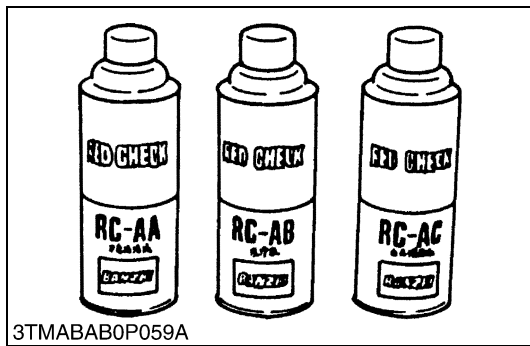

3TMABAB0P059A

**Red Check**

Code No.: 07909-31371

Application: Use to check cracks on cylinder head, cylinder block, etc.

W10249090

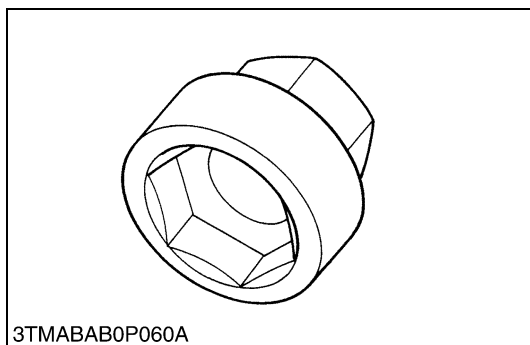

3TMABAB0P060A

**Crankshaft Nut Socket 46**

Code No.: 07916-30821

Application: Use exclusively for removing or installing the crankshaft nut.

W10443610

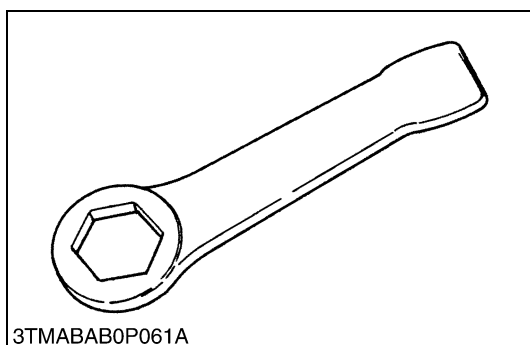

3TMABAB0P061A

**Socket Wrench 46**

Code No.: 07916-30901

Application: Use exclusively for removing or installing the crankshaft nut.

W10444600

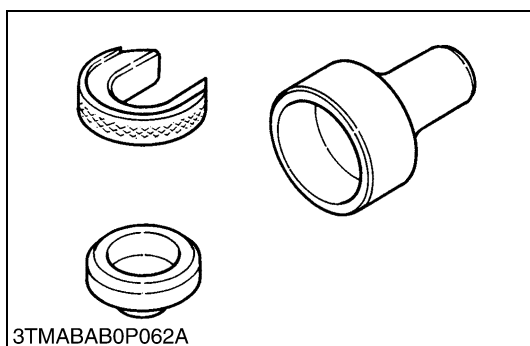

3TMABAB0P062A

**Auxiliary Socket For Fixing Crankshaft Sleeve**

Code No.: 07916-32091

Application: Use to fix the crankshaft sleeve of the diesel engine.

W10771140

NOTE

- The following special tools are not provided, so make them referring to the figure.

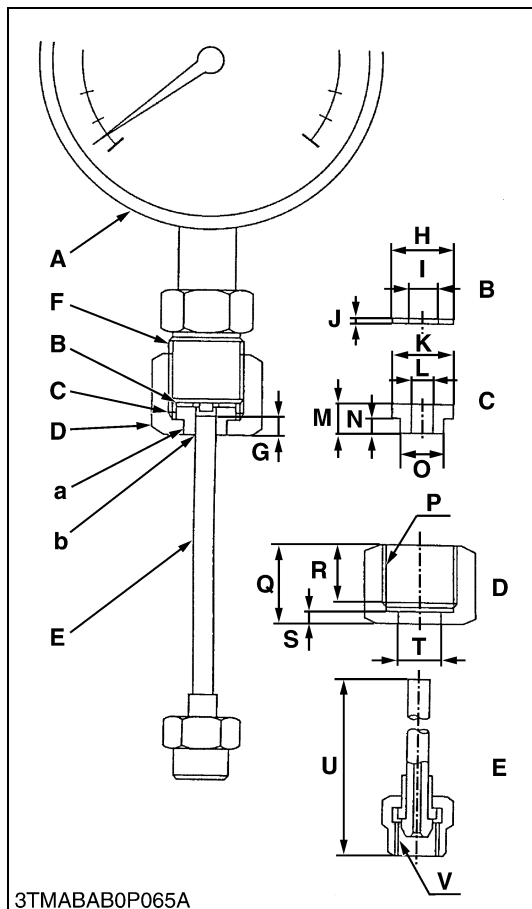
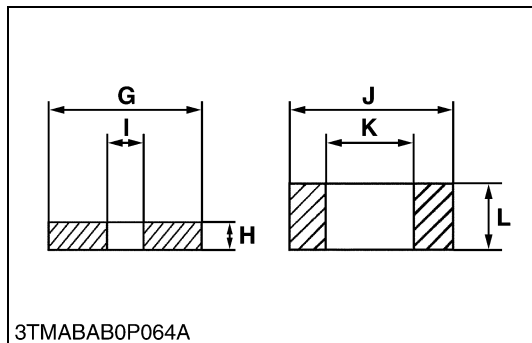
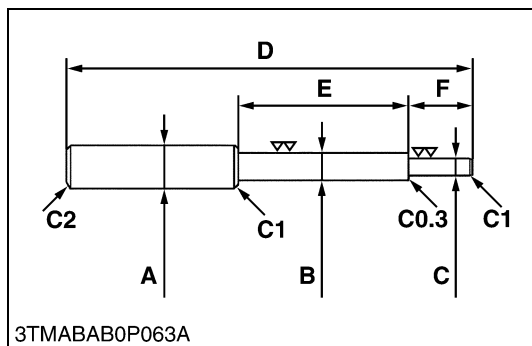

Valve Guide Replacing Tool

Application: Use to press out and press fit the valve guide.

A	20 mm dia. (0.79 in. dia.)
B	11.7 to 11.9 mm dia. (0.460 to 0.468 in. dia.)
C	6.5 to 6.6 mm dia. (0.256 to 0.259 in. dia.)
D	225 mm (8.86 in.)
E	70 mm (2.76 in.)
F	45 mm (1.77 in.)
G	25 mm (0.98 in.)
H	5 mm (0.197 in.)
I	6.7 to 7.0 mm dia. (0.263 to 0.275 in. dia.)
J	20 mm dia. (0.787 in. dia.)
K	12.5 to 12.8 mm dia. (0.492 to 0.504 in. dia.)
L	8.9 to 9.1 mm (0.350 to 358 in.)
C1	Chamfer 1.0 mm (0.039 in.)
C2	Chamfer 2.0 mm (0.079 in.)
C0.3	Chamfer 0.3 mm (0.012 in.)

W10250170

Injection Pump Pressure Tester

Application: Use to check fuel tightness of injection pumps.

A	Pressure gauge full scale : More than 29.4 MPa (300 kg/cm <sup>2</sup> , 4267 psi)
B	Copper gasket
C	Flange (Material : Steel)
D	Hex. nut 27 mm (1.06 in.) across the plat
E	Injection pipe
F	PF 1/2
G	5 mm (0.20 in.)
H	17 mm dia. (0.67 in. dia.)
I	8 mm dia. (0.31 in. dia.)
J	1.0 mm (0.039 in.)
K	17 mm dia. (0.67 in. dia.)
L	6.10 to 6.20 mm dia. (0.2402 to 0.2441 in. dia.)
M	8 mm (0.31 in.)
N	4 mm (0.16 in.)
O	11.97 to 11.99 mm dia. (0.4713 to 0.4721 in. dia.)
P	PF 1/2
Q	23 mm (0.91 in.)
R	17 mm (0.67 in.)
S	4 mm (0.16 in.)
T	12.00 to 12.02 mm dia. (0.4724 to 0.4732 in. dia.)
U	100 mm (3.94 in.)
V	M12 x P1.5
a	Adhesive application
b	Fillet welding on the enter circumference

W10252400

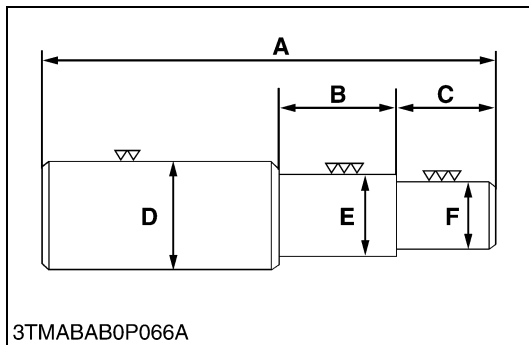

### Bushing Replacing Tools

Application: Use to press out and to press fit the bushing.

(1) For small end bushing

A	162 mm (6.38 in.)
B	35 mm (1.38 in.)
C	27 mm (1.06 in.)
D	35 mm dia. (1.38 in. dia.)
E	27.90 to 27.95 mm dia. (1.098 to 1.100 in. dia.)
F	25.00 to 25.01 mm dia. (0.984 to 0.985 in. dia.)

(2) For idle gear bushing

A	175 mm (6.89 in.)
B	40 mm (1.57 in.)
C	38 mm (1.49 in.)
D	45 mm dia. (1.77 in. dia.)
E	41.90 to 41.95 mm dia. (1.650 to 1.652 in. dia.)
F	37.95 to 37.97 mm dia. (1.494 to 1.495 in. dia.)

W10255000

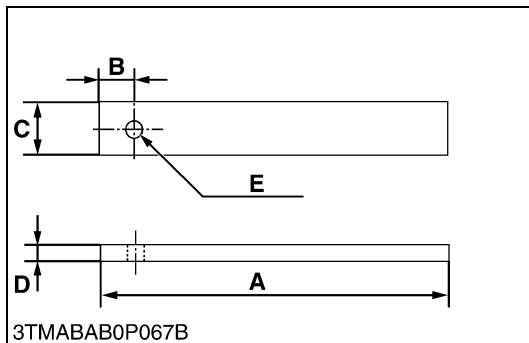

### Flywheel Stopper

Application: Use to loosen and tighten the flywheel screw.

A	200 mm (7.87 in.)
B	20 mm (0.79 in.)
C	30 mm (1.18 in.)
D	8 mm (0.31 in.)
E	10 mm dia. (0.39 in. dia.)

W10259480

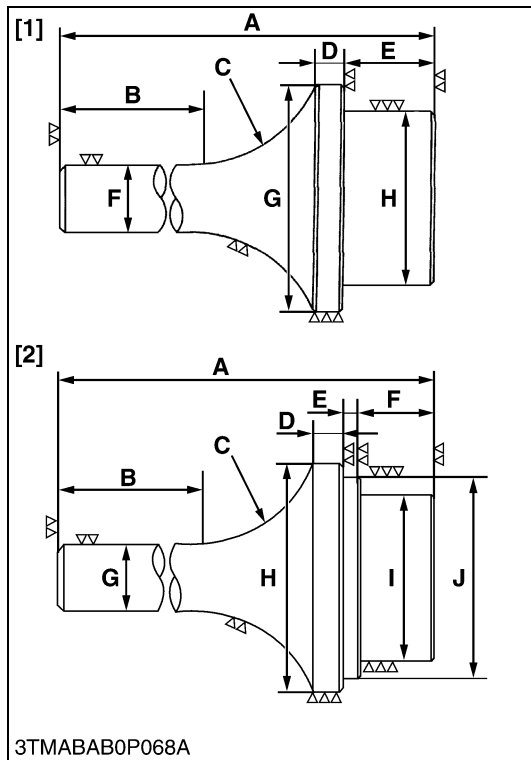

### Crankshaft Bearing 1 Replacing Tool

Application: Use to press out and press fit the crankshaft bearing 1.

#### 1. Extracting tool (D1503, D1703, V2203)

A	135 mm (5.31 in.)
B	72 mm (2.83 in.)
C	R40 mm (R1.57 in.)
D	10 mm (0.39 in.)
E	20 mm (0.79 in.)
F	20 mm dia. (0.79 in. dia.)
G	56.8 to 56.9 mm dia. (2.236 to 2.240 in. dia.)
H	51.8 to 51.9 mm dia. (2.039 to 2.043 in. dia.)

#### 2. Inserting tool (D1503, D1703, V2203)

A	130 mm (5.12 in.)
B	72 mm (2.83 in.)
C	R40 mm (R1.57 in.)
D	9 mm (0.35 in.)
E	4 mm (0.16 in.)
F	20 mm (0.79 in.)
G	20 mm dia. (0.79 in. dia.)
H	68 mm dia. (2.68 in. dia.)
I	51.8 to 51.9 mm dia. (2.039 to 2.043 in. dia.)
J	56.8 to 56.9 mm dia. (2.236 to 2.240 in. dia.)

#### 1. Extracting tool (D1803, V2403)

A	135 mm (5.31 in.)
B	72 mm (2.83 in.)
C	R40 mm (R1.57 in.)
D	10 mm (0.39 in.)
E	20 mm (0.79 in.)
F	20 mm dia. (0.79 in. dia.)
G	64.8 to 64.9 mm dia. (2.551 to 2.555 in. dia.)
H	59.8 to 59.9 mm dia. (2.354 to 2.358 in. dia.)

#### 2. Inserting tool (D1803, V2403)

A	130 mm (5.12 in.)
B	72 mm (2.83 in.)
C	R40 mm (R1.57 in.)
D	9 mm (0.35 in.)
E	4 mm (0.16 in.)
F	20 mm (0.79 in.)
G	20 mm dia. (0.79 in. dia.)
H	68 mm dia. (2.68 in. dia.)
I	59.8 to 59.9 mm dia. (2.354 to 2.358 in. dia.)
J	64.8 to 64.9 mm dia. (2.551 to 2.555 in. dia.)

W10261390

**Balancer Metal Replacing Tool (for Removing)**

Application: Use to remove the metal bearing.

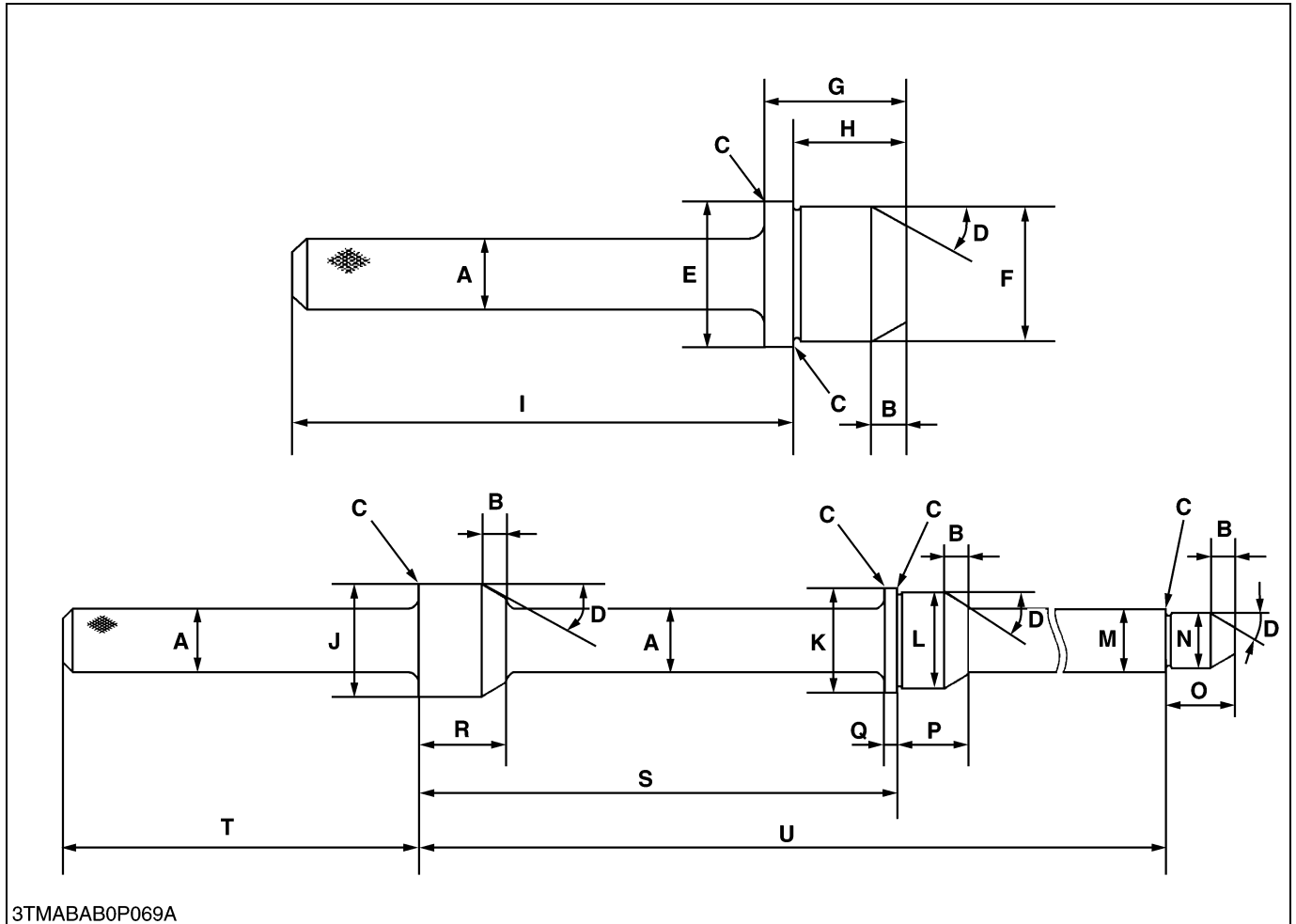

A	25 mm (0.98 in. dia.)	L	41.934 to 41.950 mm dia. (1.6509 to 1.6516 in. dia.)
B	10 mm (0.39 in.)	M	24.959 to 24.980 mm dia. (0.9826 to 0.9835 in. dia.)
C	Chamfer 0.3 mm (0.01 in.)	N	21.947 to 21.960 mm dia. (0.8641 to 0.8646 in. dia.)
D	0.52 rad (30 °)	O	28 mm (1.10 in.)
E	46.950 to 46.975 mm dia. (1.8484 to 1.8494 in. dia.)	P	29 mm (1.14 in.)
F	43.934 to 43.950 mm dia. (1.7297 to 1.7303 in. dia.)	Q	5 mm (0.20 in.)
G	41 mm (1.61 in.)	R	36 mm (1.42 in.)
H	32.5 mm (1.28 in.)	S	195.25 to 195.75 mm (7.687 to 7.707 in.)
I	148.5 mm (5.85 in.)	T	145 mm (5.71 in.)
J	46.50 to 46.75 mm dia. (1.831 to 1.841 in. dia.)	U	384.75 to 385.25 mm (15.148 to 15.167 in.)
K	44.950 to 44.975 mm dia. (1.7697 to 1.7707 in. dia.)		

**Balancer Metal Replacing Tool (for Fitting)**

Application: Use to press fit the metal bearing.

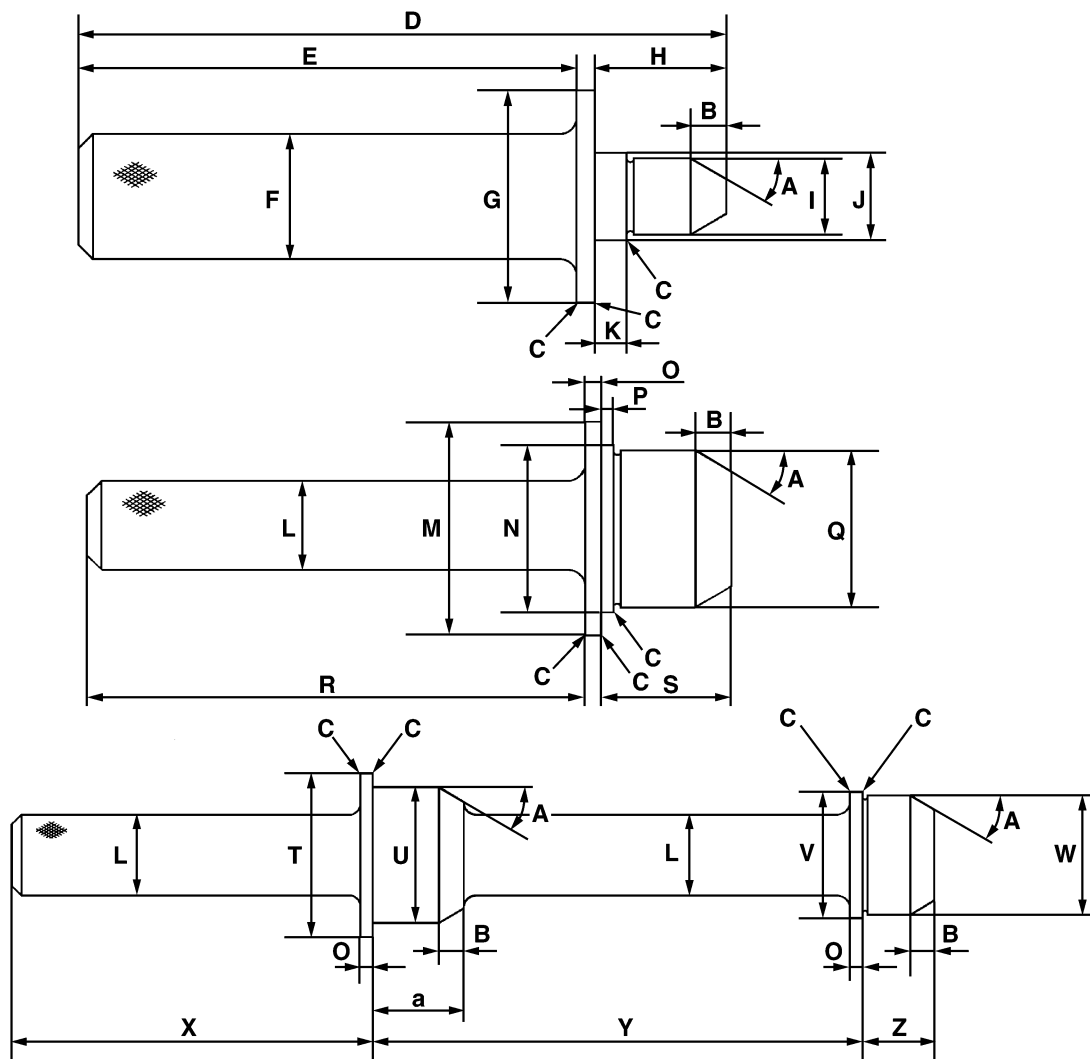

3TMABAB0P070A

A	0.52 rad (30 °)	O	5 mm (0.20 in.)
B	10 mm (0.39 in.)	P	3.3 to 3.7 mm (0.130 to 0.146 in.)
C	Chamfer 0.3 mm (0.01 in.)	Q	43.934 to 43.950 mm dia. (1.7297 to 1.7303 in. dia.)
D	182 mm (7.16 in.)	R	140 mm (5.51 in.)
E	140 mm (5.51 in.)	S	36 mm (1.42 in.)
F	35 mm dia. (1.38 in dia.)	T	60 mm dia. (2.36 in. dia.)
G	60 mm dia. (2.36 in dia.)	U	46.950 to 46.975 mm dia. (1.8484 to 1.8494 in. dia.)
H	37 mm (1.46 in.)	V	44.950 to 44.975 mm dia. (1.7697 to 1.7707 in. dia.)
I	21.947 to 21.960 mm dia. (0.8641 to 0.8646 in. dia.)	W	41.934 to 41.950 mm dia. (1.6509 to 1.6516 in. dia.)
J	24.959 to 24.980 mm dia. (0.9826 to 0.9835 in. dia.)	X	145 mm (5.71 in.)
K	8.8 to 9.2 mm (0.346 to 0.362 in.)	Y	195.25 to 195.75 mm (7.687 to 7.707 in.)
L	25 mm dia. (0.98 in. dia.)	Z	29 mm (1.14 in.)
M	60 mm dia. (2.36 in. dia.)	a	36 mm (1.42 in.)
N	46.950 to 46.975 mm dia. (1.8484 to 1.8494 in. dia.)		

## [2] SPECIAL TOOLS FOR TRACTOR

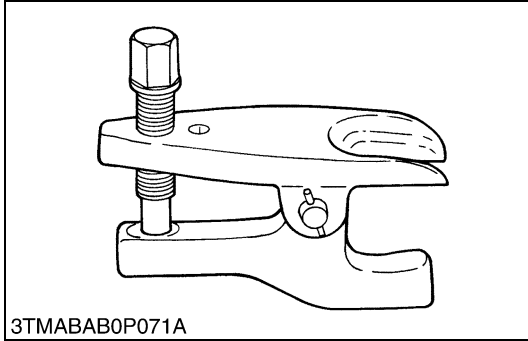

3TMABAB0P071A

### Tie-rod End Lifter

Code No.: 07909-39051

Application: Use for removing the tie-rod end with ease.

W10264720

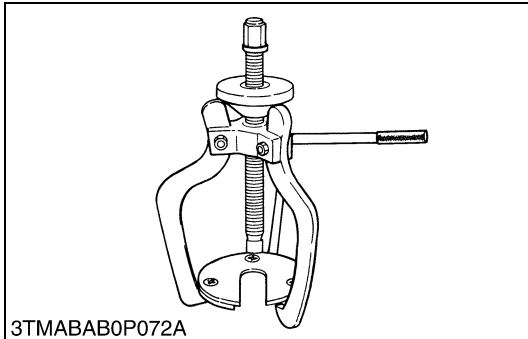

3TMABAB0P072A

### Steering Wheel Puller

Code No.: 07916-51090

Application: Use for removing the steering wheel without damaging the steering shaft.

W10265330

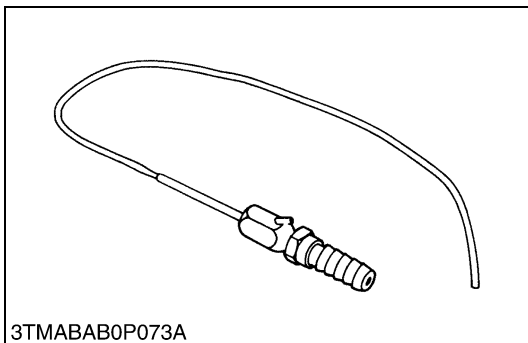

3TMABAB0P073A

### Injector CH3

Code No.: 07916-52501

Application: Use for injecting calcium chloride solution into, and removing it from, rear and 4WD type front wheel tires.

W10265850

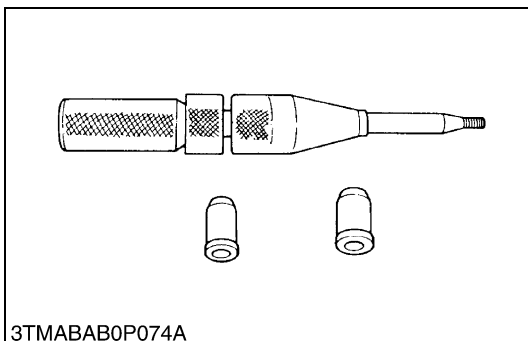

3TMABAB0P074A

### Clutch Center Tool (For B and L Series Tractors)

Application: The clutch center tool can be used for all **B** and **L** series tractors with a diaphragm clutch by changing tip guides. Center piece diameter is 20 mm (0.79 in.).

W10266370

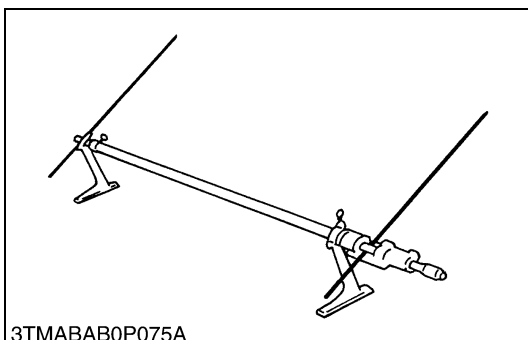

3TMABAB0P075A

### Toe-in Gauge

Code No.: 07909-31681

Application: This allows easy measurement of toe-in for all machine models.

W10266890

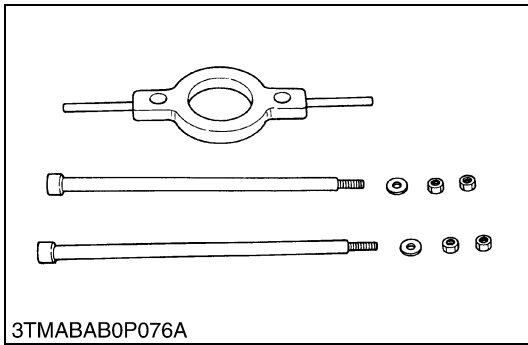

3TMABAB0P076A

**Rear Axle Cover Puller**

Code No.: 07916-51041

Application: Use for removing a rear axle cover from rear axle.

W10732590

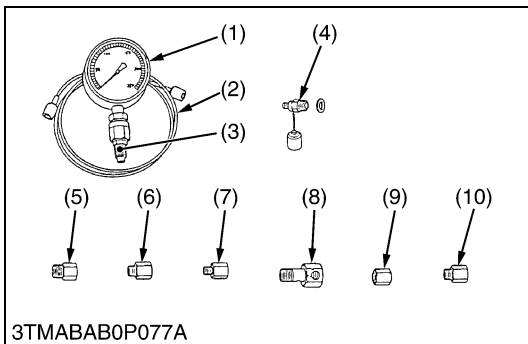

3TMABAB0P077A

**Relief Valve Pressure Tester**

Code No.: 07916-50045

Application: This allows easy measurement of relief set pressure.

- |  |                                       |
|--|---------------------------------------|
| (1) Gauge (07916-50322)                  | (6) Adaptor C (PS3/8) (07916-50371)   |
| (2) Cable (07916-50331)                  | (7) Adaptor D (PT1/8) (07916-50381)   |
| (3) Threaded Joint (07916-50401)         | (8) Adaptor E (PS3/8) (07916-50392)   |
| (4) Threaded Joint (07916-50341)         | (9) Adaptor F (PF1/2) (07916-62601)   |
| (5) Adaptor B (M18 × P1.5) (07916-50361) | (10) Adaptor 58 (PT1/4) (07916-52391) |

W10267410

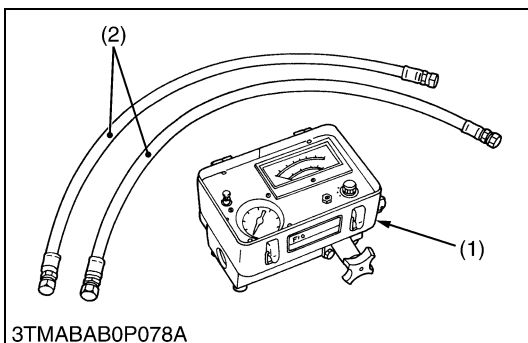

3TMABAB0P078A

**Flow Meter**

Code No.: 07916-52791 (Flow Meter)

07916-52651 (Hydraulic Test Hose)

Application: This allows easy testing of hydraulic system.

- |                |                         |
|----------------|-------------------------|
| (1) Flow Meter | (2) Hydraulic Test Hose |
|----------------|-------------------------|

W10313180

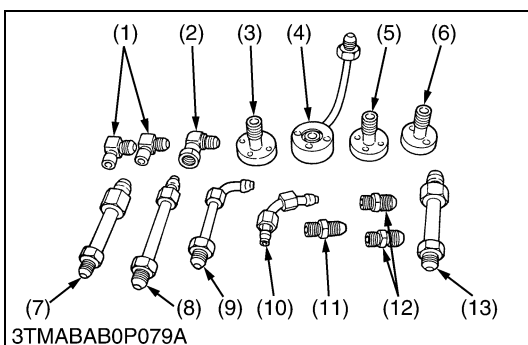

3TMABAB0P079A

**Adaptor Set for Flow Meter**

Code No.: 07916-54031

Application: Use for testing the hydraulic system.

- |                |                          |
|----------------|--------------------------|
| (1) Adaptor 52 | (8) Adaptor 65           |
| (2) Adaptor 53 | (9) Adaptor 66           |
| (3) Adaptor 54 | (10) Adaptor 67          |
| (4) Adaptor 61 | (11) Adaptor 68          |
| (5) Adaptor 62 | (12) Adaptor 69          |
| (6) Adaptor 63 | (13) Hydraulic Adaptor 1 |
| (7) Adaptor 64 |                          |

W10313960

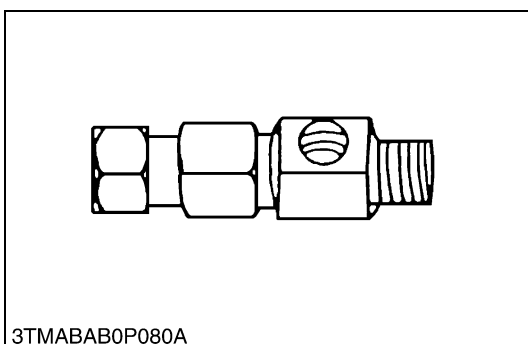

3TMABAB0P080A

**Power Steering Adapter**

Code No.: 07916-54021

Application: Use for measuring the relief valve setting pressure for power steering.

W10442870



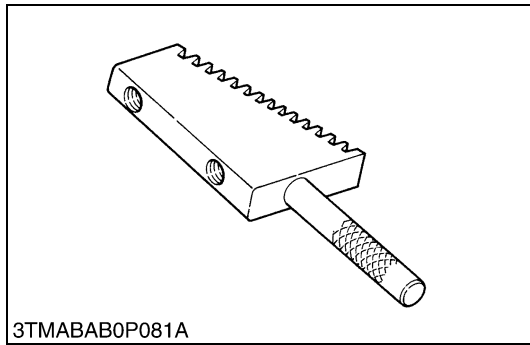

3TMABAB0P081A

**Pinion Locking Tool**

Code No.: 07916-52311

Application: Use for preventing the shaft from turning when removing or tighten a bevel pinion shaft staking nut.

W10445520

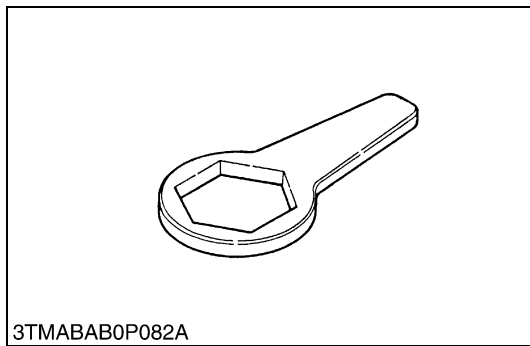

3TMABAB0P082A

**Rear Axle Nut Wrench 71**

Code No.: 07916-52531

Application: Use for removing and installing a rear axle nut.

W10446460

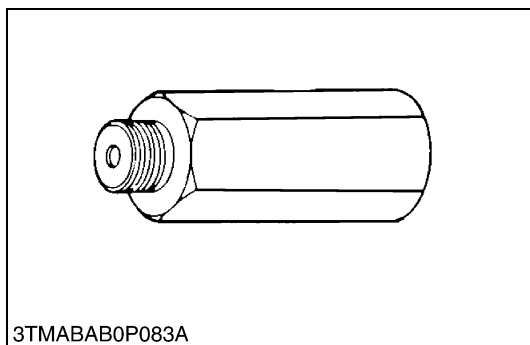

3TMABAB0P083A

**Relief Valve Setting Pressure Adaptor G**

Code No.: 07916-52751

Application: This offers easy measurement of relief valve setting pressure from the hydraulic coupler. This is available with the relief valve setting pressure tester.

W10623960

**NOTE**

- The following special tools are not provided, so make them referring to the figure.

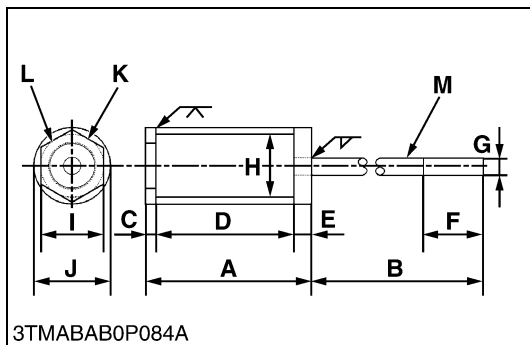

3TMABAB0P084A

**Pinion Shaft Remover**

Application: Use for removing a pinion shaft.

A	106 mm (4.17 in.)
B	350 mm (13.78 in.)
C	6 mm (0.24 in.)
D	90 mm (3.54 in.)
E	10 mm (0.39 in.)
F	40 mm (1.57 in.)
G	10 mm (0.39 in.)
H	35.6 mm (1.40 in.)
I	36 mm (1.42 in.)
J	41.6 mm (1.64 in.)
K	Part code No. 3A201-4130 nut
L	M27 × P1.5
M	M10 × P1.25

W10315930

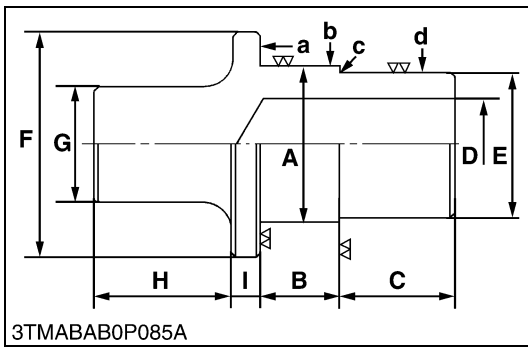

### Hydraulic Arm Shaft Bushing Press-Fitting Tool

Application: Use for replacing the hydraulic arm shaft bushings in the hydraulic cylinder body.

	Right	Left
A	54.7 to 54.9 mm (2.1535 to 2.1614 in.)	49.7 to 49.9 mm (1.9567 to 1.9646 in.)
B	24.5 to 25.5 mm (0.9646 to 1.0039 in.)	21.5 to 22.5 mm (0.8465 to 0.8858 in.)
C	40 mm (1.57 in.)	40 mm (1.57 in.)
D	32 mm (1.26 in.)	30 mm (1.18 in.)
E	49.7 to 49.9 mm (1.9567 to 1.9646 in.)	44.7 to 44.9 mm (1.7598 to 1.7677 in.)
F	70 mm dia. (2.76 in. dia.)	
G	40 mm dia. (1.57 in. dia.)	
H	50 mm (1.97 in.)	
I	10 mm (0.39 in.)	
a	6.3 $\mu\text{m}$ (250 $\mu\text{in.}$ )	
b	6.3 $\mu\text{m}$ (250 $\mu\text{in.}$ )	
c	6.3 $\mu\text{m}$ (250 $\mu\text{in.}$ )	
d	6.3 $\mu\text{m}$ (250 $\mu\text{in.}$ )	

W10316550

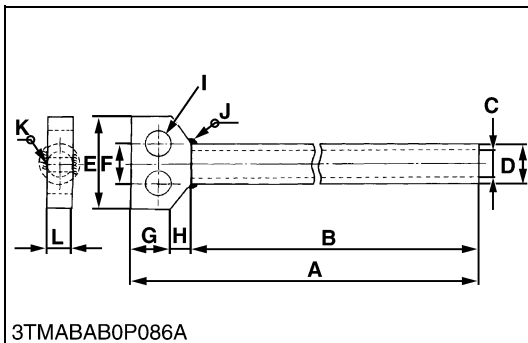

### Draft Control Test Bar

Application: Use for checking the lift range and floating range of hydraulic draft control.

A	1045 mm (41.14 in.)
B	1000 mm (29.37 in.)
C	20 mm dia. (0.79 in. dia.)
D	30 mm dia. (1.18 in. dia.)
E	90 mm (3.54 in.)
F	30 mm (1.18 in.)
G	30 mm (1.18 in.)
H	15 mm (0.59 in.)
I	20 mm dia. (0.79 in. dia.)
J	Weld all around
K	Weld all around
L	20 mm (0.79 in.)

W10625190

## NOTE

- Special tools for R134a refrigerant air conditioning system introduced below are available from NIPPONDENSO CO. LTD.

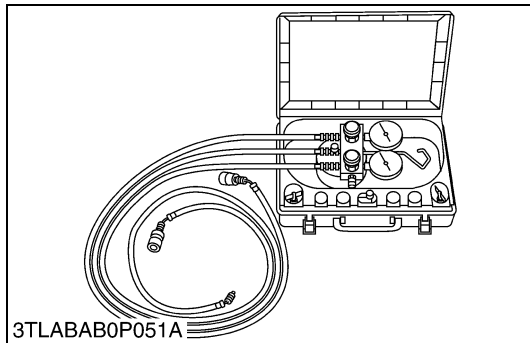

### Air Conditioner Service Tool

Code No.: DENSO.CO. 95048-00061

Application: Use for charging, testing or discharging the air conditioning system.

W1013507

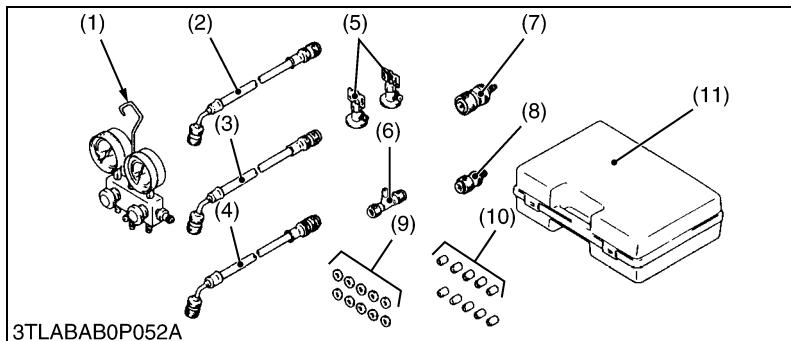

(1) Manifold Gauge Assembly	95048-10090
(2) Charging Hose (Red : HI)	95948-10270
(3) Charging Hose (Blue : LO)	95948-10280
(4) Charging Hose (Green)	95948-10260
(5) Can Tap Valve	95048-10150
(6) T Joint	95048-10160
(7) Quick Coupler (HI)	95048-10130
(8) Quick Coupler (LO)	95048-10140
(9) Service Valve Packing	95906-10310
(10) Charging Hose Packing	95906-10300
(11) Tool Case	95949-10610

W1014733

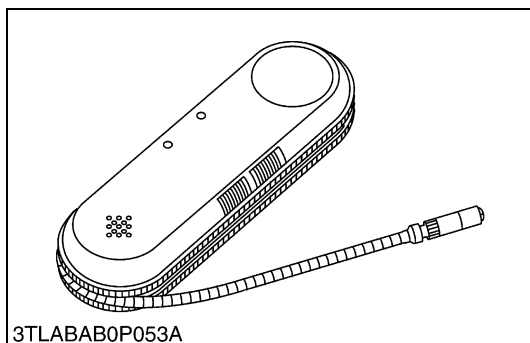

### Electric Gas Leak Tester

Code No.: DENSO.CO. 95146-00060

Application: Use for gas leak testing the air conditioning system.

W1013817

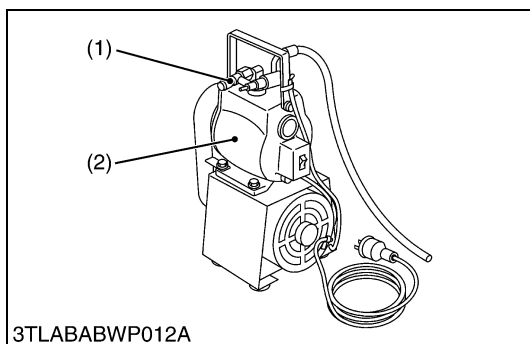

### Vacuum Pump

Code No.: DENSO.CO. 95046-00040 (AC220V)  
95046-00050 (AC240V)

Application: Use for evacuating the air conditioning system.

- (1) Adaptor (For 134a)                      (2) Vacuum Pump

W1013764

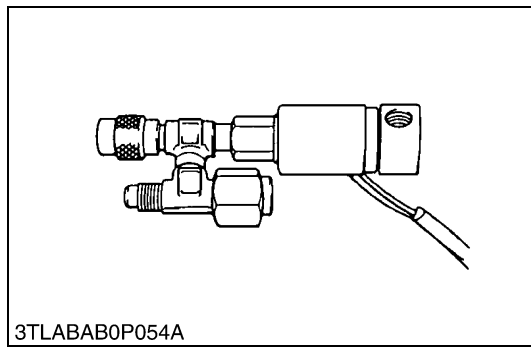

**Adaptor (For R134a)**

Code No.: DENSO.CO. 95048-10190 (AC220V)  
 95048-10200 (AC240V)

Application: Use for evacuating the air conditioning system.

W1013888

**Stopper Magnet Clutch (For A/C Compressor)**

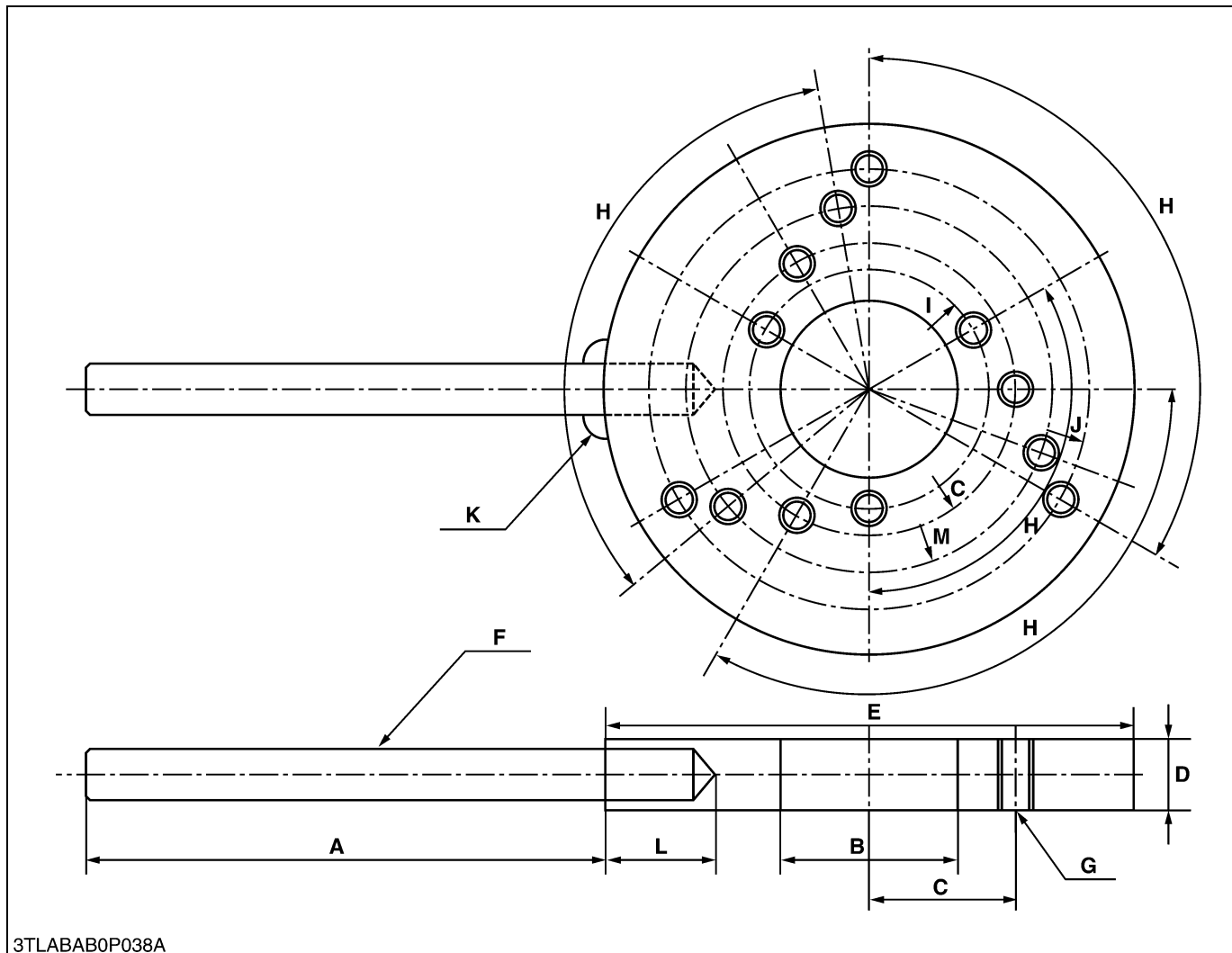

3TLABAB0P038A

Application: Use for loosen and tighten the magnet clutch mounting nut.

■ **NOTE**

- This special tool is not provided, so make it referring to the figure.

A	125 mm (4.92 in.)	H	4.52 rad (120 °)
B	40 mm dia. (1.57 in. dia.)	I	Radius 27 mm (Radius 1.06 in.)
C	Radius 33 mm (Radius 1.30 in.)	J	Radius 50 mm (Radius 1.97 in.)
D	16 mm (0.63 in.)	K	Weld all around
E	120 mm dia. (4.72 in. dia.)	L	20 mm (0.78 in.)
F	12 mm dia. (0.47 in. dia.)	M	Radius 41 mm (Radius 1.61 in.)

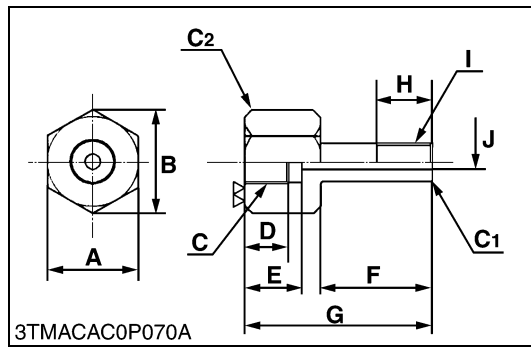

### Valve Adaptor

Application: Use for measuring the system pressure of shuttle valve.

<b>A</b>	24 mm (0.94 in.)
<b>B</b>	27.7 mm (1.09 in.)
<b>C</b>	PS1/4
<b>D</b>	11 mm (0.43 in.)
<b>E</b>	15 mm (0.59 in.)
<b>F</b>	40 mm (1.57 in.)
<b>G</b>	60 mm (2.36 in.)
<b>H</b>	15 mm (0.59 in.)
<b>I</b>	PT1/8
<b>J</b>	4 mm dia. (0.15 in. dia.)
<b>C1</b>	Chamfer 1 mm (0.039 in.)
<b>C2</b>	Chamfer 2 mm (0.079 in.)

W1039227

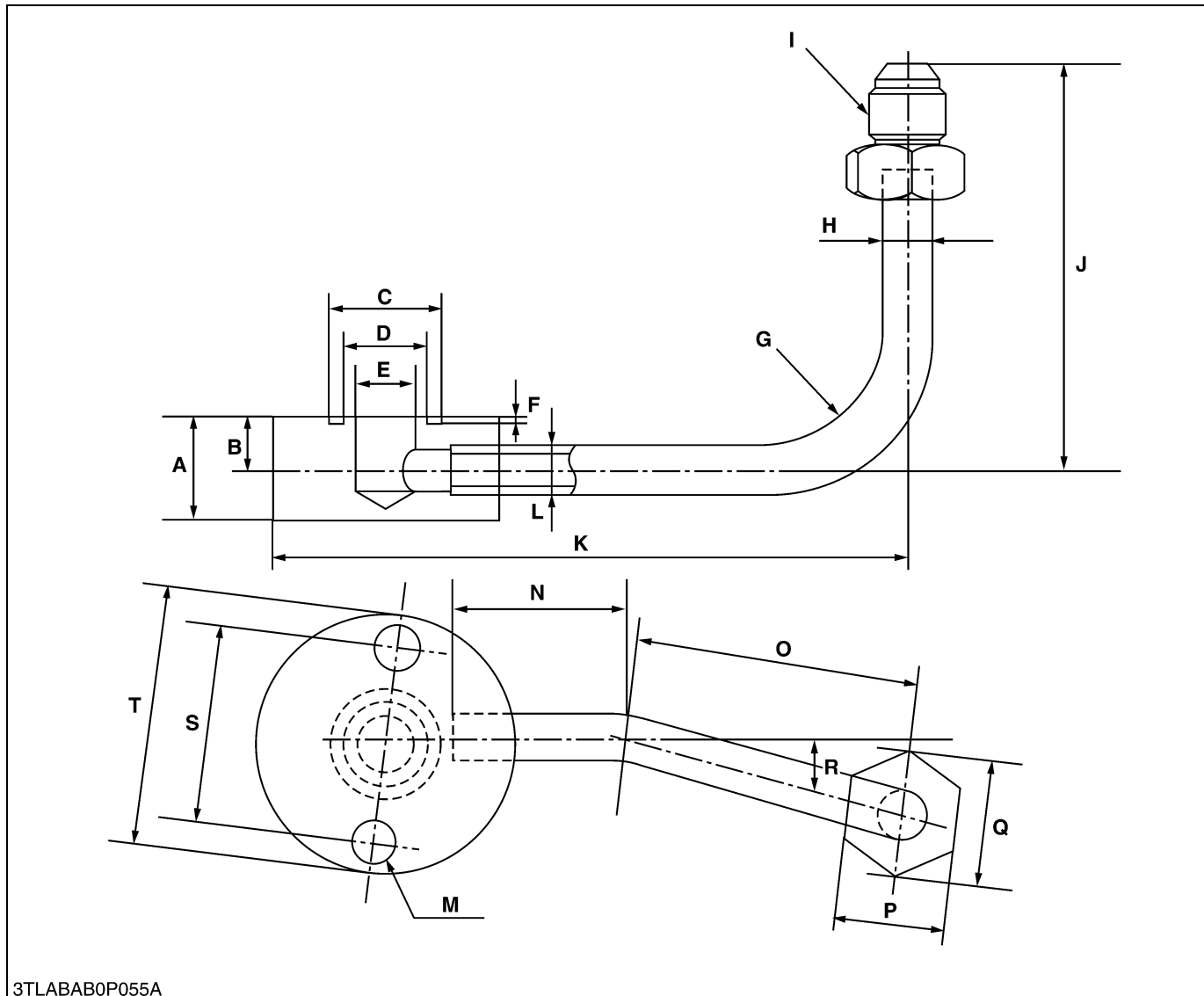
**Pump Adaptor**

3TLABAB0P055A

Application: Use for checking the main hydraulic pump.

**NOTE**

- When using, attach with following parts.  
O-ring : 04811-00180
- This adaptor is modified from Adaptor 61 of flowmeter adaptor set (see page G-48).

A	22 mm (0.872 in.)	K	135 mm (5.31 in.)
B	11 mm (0.437 in.)	L	7 mm dia. (0.28 in. dia.)
C	24 mm dia. (0.94 in. dia.)	M	8.5 mm dia. (0.33 in. dia.)
D	18 mm dia. (0.71 in. dia.)	N	37 mm (1.46 in.)
E	12 mm dia. (0.47 in. dia.)	O	61.5 mm (2.42 in.)
F	1.7 to 1.9 mm (0.067 to 0.075 in.)	P	24 mm (0.94 in.)
G	30 mm Round (1.18 in. Round)	Q	27.7 mm (1.09 in.)
H	10 mm dia. (0.39 in. dia.)	R	0.244 rad (14 °)
I	G 3/8	S	40 mm (1.57 in.)
J	89 mm (3.50 in.)	T	60 mm dia. (2.36 in. dia.)

**(Reference)**

- From size A to size R are same size as adaptor 61.

## 9. TIRES

### [1] TIRE PRESSURE

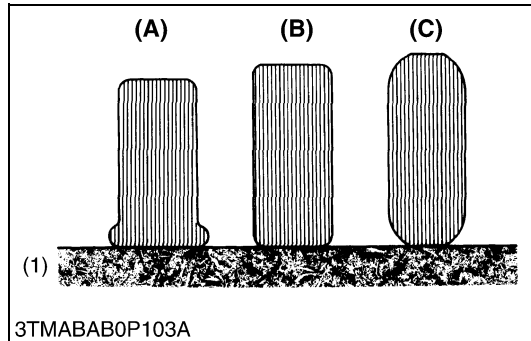

#### ⚠ WARNING

- Do not attempt to mount a tire on a rim. This should be done by a qualified person with the proper equipment.
- Always maintain the correct tire pressure. Do not inflate tires above the recommended pressure shown in the operator's manual.

#### ■ IMPORTANT

- Do not use tires other than those approved by KUBOTA.

#### ■ Inflation Pressure

Though the tire pressure is factory-set to the prescribed level, it naturally drops slowly in the course of time. Thus, check it everyday and inflate as necessary.

	Tire sizes	Inflation Pressure
Rear	11.2-24, 4PR	120 kPa (1.2 kgf/cm <sup>2</sup> , 17 psi)
	12.4-24, 4PR	100 kPa (1.0 kgf/cm <sup>2</sup> , 14 psi)
	13.6-24, 4PR	100 kPa (1.0 kgf/cm <sup>2</sup> , 14 psi)
	13.6-26, 4PR	100 kPa (1.0 kgf/cm <sup>2</sup> , 14 psi)
	13.6-28, 6PR	140 kPa (1.4 kgf/cm <sup>2</sup> , 20 psi)
	355/80-D20, 4PR	100 kPa (1.0 kgf/cm <sup>2</sup> , 14 psi)
	475/65-D20, 4PR	80 kPa (0.8 kgf/cm <sup>2</sup> , 12 psi)
Front	7-16, 4PR	180 kPa (1.8 kgf/cm <sup>2</sup> , 26 psi)
	8-16, 4PR	160 kPa (1.6 kgf/cm <sup>2</sup> , 23 psi)
	9.5-16, 4PR	220 kPa (2.2 kgf/cm <sup>2</sup> , 32 psi)
	212/80-D15, 4PR	160 kPa (1.6 kgf/cm <sup>2</sup> , 23 psi)
	29 × 12.00-15, 4PR	140 kPa (1.4 kgf/cm <sup>2</sup> , 20 psi)

#### ■ NOTE

- Maintain the maximum pressure in front tires, if using a front loader or when equipped with a full load of front weights.

(A) Insufficient  
(B) Standard  
(C) Excessive

(1) Ground

W10440050

## [2] TREADS ADJUSTMENT

### CAUTION

- When working on slopes or working with trailer, set the wheel tread as wide as practice for the job for maximum stability.
- Support tractor securely on stands before removing a wheel.
- Do not work under any hydraulically supported devices. They can settle, suddenly leak down, or be accidentally lowered. If necessary to work under tractor or any machine elements for servicing or adjustment, securely support them with stands or suitable blocking beforehand.
- Never operate tractor with a loose rim, wheel, or axle.

### (1) Front Wheels

Front axle is not adjustable

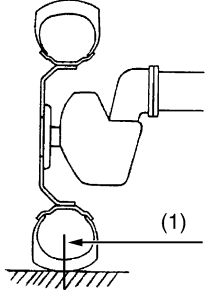
 <p>3TMABAB0P095B</p>	Models	L3130, L3430				
	Tire	7-16 Farm	–	–	212/80-D15 Turf	–
	Tread	1150 mm (45.3 in.)	–	–	1180 mm (46.5 in.)	–
	Models	L3830, L4630				
	Tire	7-16 Farm	8-16 Farm	–	212/80-D15 Turf	29 × 12.00-15 Turf
	Tread	1150 mm (45.3 in.)	1145 mm (45.1 in.)	–	1180 mm (46.5 in.)	1270 mm (50.0 in.)
	Models	L5030				
	Tire	–	–	9.5-16 Farm	–	29 × 12.00-15 Turf
	Tread	–	–	1135 mm (44.7 in.)	–	1210 mm (47.6 in.)

(1) Tread

W10527070

### (2) Rear Wheels

Rear tread can be adjusted in 6 steps depending on the model.

#### To change the tread

1. Lift the rear tires off the ground.
2. Follow the illustrations below to get the desired tread width.

#### ■ IMPORTANT

- If not attached as illustrated, transmission parts may be damaged.
- When re-fitting or adjusting a wheel, tighten the bolts to the following torques then recheck after driving the tractor 200 m (200 yards) and thereafter according to service interval.

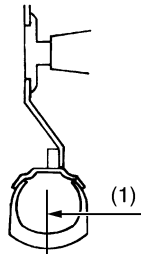
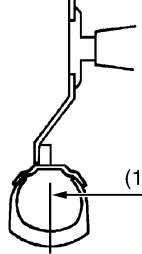
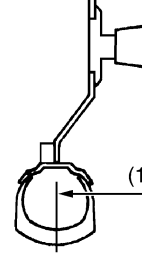
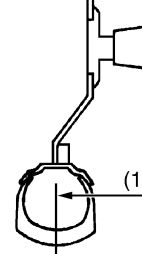

Models	 3TLABAB0P069A	 3TMABAB0P097B	 3TMABAB0P098B	 3TMABAB0P099B
L3130, L3430 11.2-24 Farm	1110 mm (43.7 in.)	1205 mm (47.4 in.)	1300 mm (51.2 in.)	1385 mm (54.5 in.)
L3130, L3430 11.2-24 Farm	1110 mm (43.7 in.)	1205 mm (47.4 in.)	1300 mm (51.2 in.)	1385 mm (54.5 in.)
L3830, L4630 12.4-24 Farm	1130 mm (44.5 in.)	1220 mm (48.0 in.)	1320 mm (52.0 in.)	1400 mm (55.1 in.)
L3830, L4630 13.6-24 Farm	1140 mm (44.9 in.)	1210 mm (47.6 in.)	1310 mm (51.6 in.)	1410 mm (55.5 in.)
L3830, L4630 13.6-26 Farm	1140 mm (44.9 in.)	1210 mm (47.6 in.)	1310 mm (51.6 in.)	1335 mm (52.6 in.)
L5030 13.6-28 Farm	1125 mm (44.3 in.)	1225 mm (48.2 in.)	1325 mm (52.2 in.)	—

W10529090

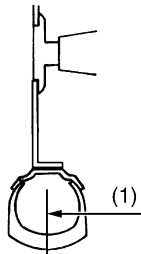
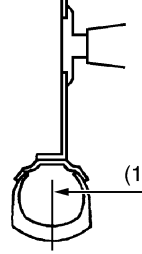
Models	 3TLABAB0P070A	 3TMABAB0P101B
L3130, L3430 355/80-D20 Turf	1125 mm (44.3 in.)	1190 mm (46.9 in.)
L3830, L4630 355/80-D20 Turf	1140 mm (44.9 in.)	1210 mm (47.6 in.)
L3830, L4630, L5030 475/65-D20 Turf	—	1285 mm (50.6 in.)

(1) Tread

W10531370

### [3] TIRE LIQUID INJECTION

Auxiliary weights can be used to increase traction force for plowing in fields or clayey ground.

Another way is to inject water or another liquid, such as a calcium chloride solution in the tires. Water must not be used in winter since it freezes at 0 °C (32 °F). The calcium chloride solution will not freeze and moreover, affords higher effect than water since its specific gravity is higher than that of water by about 20 %. Below is an explanation of calcium chloride solution injection.

#### ■ IMPORTANT

- Do not fill the front tires with liquid.

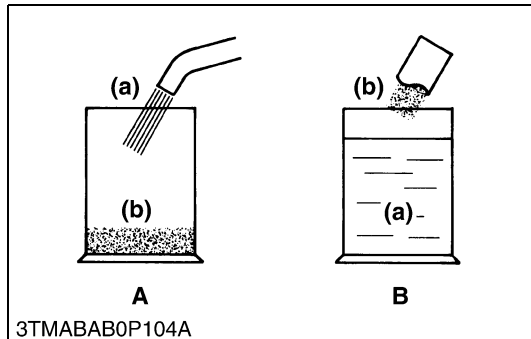

#### Preparation of Calcium Chloride Solution

#### ⚠ CAUTION

- When making a calcium chloride solution, do not pour water over calcium chloride since this results in chemical reaction which will cause high temperature. Instead add a small amount of calcium chloride to the water at a time until the desired solution is achieved.

Freezing temp.	Weight of CaCl <sub>2</sub> to be dissolved in 100 L (26.5 U.S.gals, 22.0 Imp.gals) of water
-5 °C (23 °F)	12 kg (26.4 lbs)
-10 °C (14 °F)	21 kg (46.3 lbs)
-15 °C (5 °F)	28 kg (61.7 lbs)
-20 °C (-4 °F)	34 kg (75.0 lbs)
-25 °C (-13 °F)	40 kg (88.2 lbs)
-30 °C (-22 °F)	44 kg (97.0 lbs)
-35 °C (-31 °F)	49 kg (108 lbs)
-40 °C (-40 °F)	52 kg (114.6 lbs)
-45 °C (-49 °F)	56 kg (123.5 lbs)
-50 °C (-58 °F)	61 kg (134.5 lbs)

(a) Water

(b) CaCl<sub>2</sub> (Calcium Chloride)

W10330830

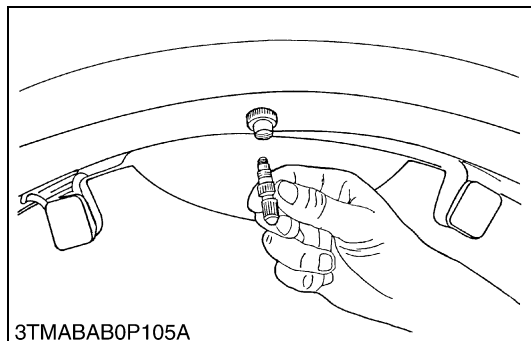

#### Attaching Injector

1. Lift the rear tires off the ground.
2. Turn the tire so that the air valve is at the top.
3. Remove the air valve, and attach the injector. (Code No. 07916-52501)

(1) Injector

(2) Hose

W10333310

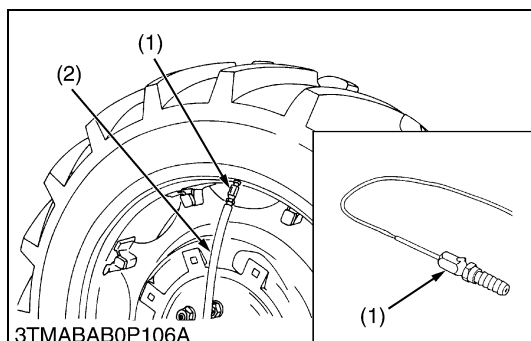

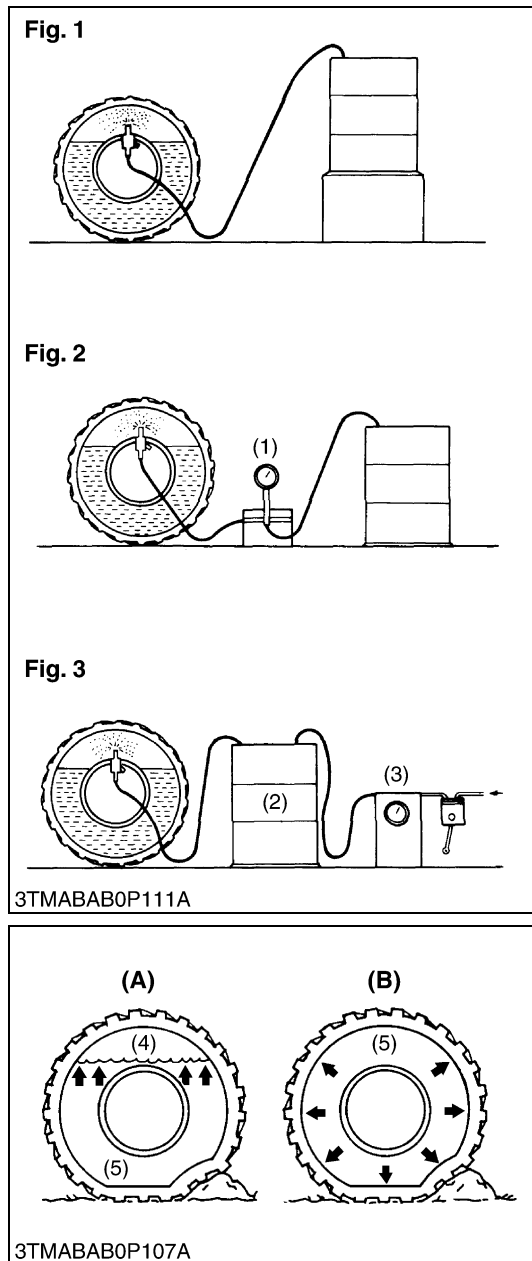

**Injection**

**CAUTION**

- When a calcium chloride solution is used, cool it before pouring it into the tire.
- Do not fill tires with water or solution more than 75 % of full capacity (to the valve stem level).

The following four ways can be used to inject water or a calcium chloride solution into tires.

1. Gravity injection (Fig. 1)
2. Pump injection (Fig. 2)
3. Pressure tank injection (Fig. 3)
4. Injection directly from tap (only when water is being used).

**NOTE**

- Once injection is completed, reset the air valve, and pump air into the tire to the specified pressure.

Weight of Calcium Chloride Solution Filling 75 % of Full Capacity of a Tire

Tire sizes	11.2-24	12.4-24	13.6-24
Slush free at -10 °C (14 °F) Solid at -30 °C (-22 °F) [Approx. 1 kg (2 lbs) CaCl <sub>2</sub> per 4 L (1 gals) of water]	103 kg (227 lbs)	117 kg (258 lbs)	153 kg (337 lbs)
Slush free at -24 °C (-11 °F) Solid at -47 °C (-53 °F) [Approx. 1.5 kg (3.5 lbs) CaCl <sub>2</sub> per 4 L (1 gals) of water]	108 kg (238 lbs)	125 kg (276 lbs)	160 kg (353 lbs)
Slush free at -47 °C (-53 °F) Solid at -52 °C (-62 °F) [Approx. 2.25 kg (5 lbs) CaCl <sub>2</sub> per 4 L (1 gals) of water]	115 kg (254 lbs)	133 kg (293 lbs)	170 kg (375 lbs)

Tire sizes	13.6-26	13.6-28
Slush free at -10 °C (14 °F) Solid at -30 °C (-22 °F) [Approx. 1 kg (2 lbs) CaCl <sub>2</sub> per 4 L (1 gals) of water]	172 kg (379 lbs)	185 kg (408 lbs)
Slush free at -24 °C (-11 °F) Solid at -47 °C (-53 °F) [Approx. 1.5 kg (3.5 lbs) CaCl <sub>2</sub> per 4 L (1 gals) of water]	181 kg (399 lbs)	200 kg (441 lbs)
Slush free at -47 °C (-53 °F) Solid at -52 °C (-62 °F) [Approx. 2.25 kg (5 lbs) CaCl <sub>2</sub> per 4 L (1 gals) of water]	192 kg (423 lbs)	215 kg (474 lbs)

- (1) Pump
- (2) Pressure Tank
- (3) Compressor
- (4) Air
- (5) Water

**(A) Correct : 75 %  
Air Compresses Like A Cushion**  
**(B) Incorrect : 100 % Full  
Water Can Not Be Compressed**

W10334350

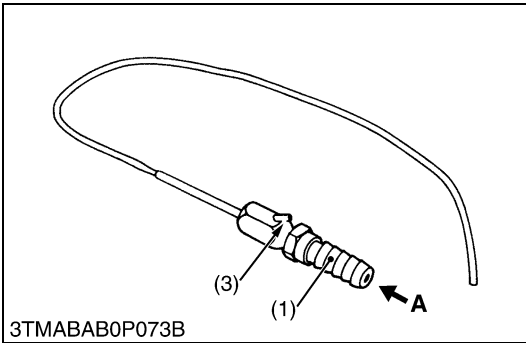
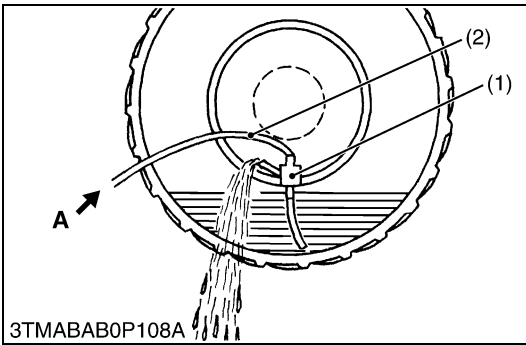

### **Draining Water or Solution**

1. Lift the rear tires off the ground.
2. Turn the tire so that the air valve is at the bottom.
3. Remove the air valve, and drain liquid (liquid can only be drained to the level of the valve and liquid under that level remains inside).
4. To drain liquid completely, use the injector, and direct compressed air into the tire to force out the liquid through the injector's vent.

- (1) Injector  
 (2) Hose  
 (3) Vent

**A: Compressed Air**

W10451670

# 1 ENGINE

# MECHANISM

## CONTENTS

1. FEATURES .....	1-M1
2. FUEL SYSTEM .....	1-M2
3. LUBRICATING SYSTEM .....	1-M3
4. COOLING SYSTEM.....	1-M4

# 1. FEATURES

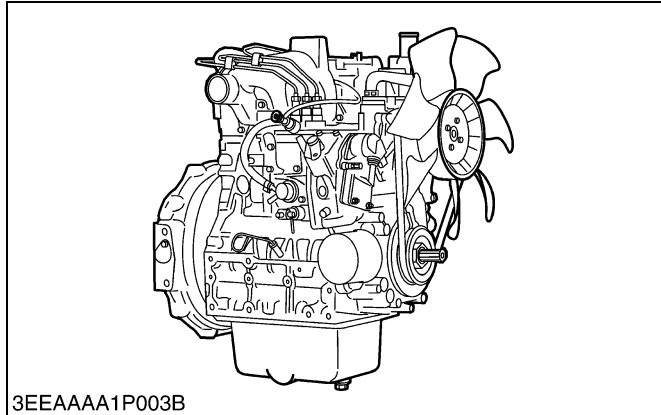

The engine model shown in the table below is adopted in the L30 series tractor. These are 03-M series engine.

Tractor Model	Engine Model
L3130	D1503-MA-E
L3430	D1703-MA-E
L3830	D1803-MA-E
L4630	V2203-MA-E
L5030	V2403-MA-E

W1012642

## 2. FUEL SYSTEM

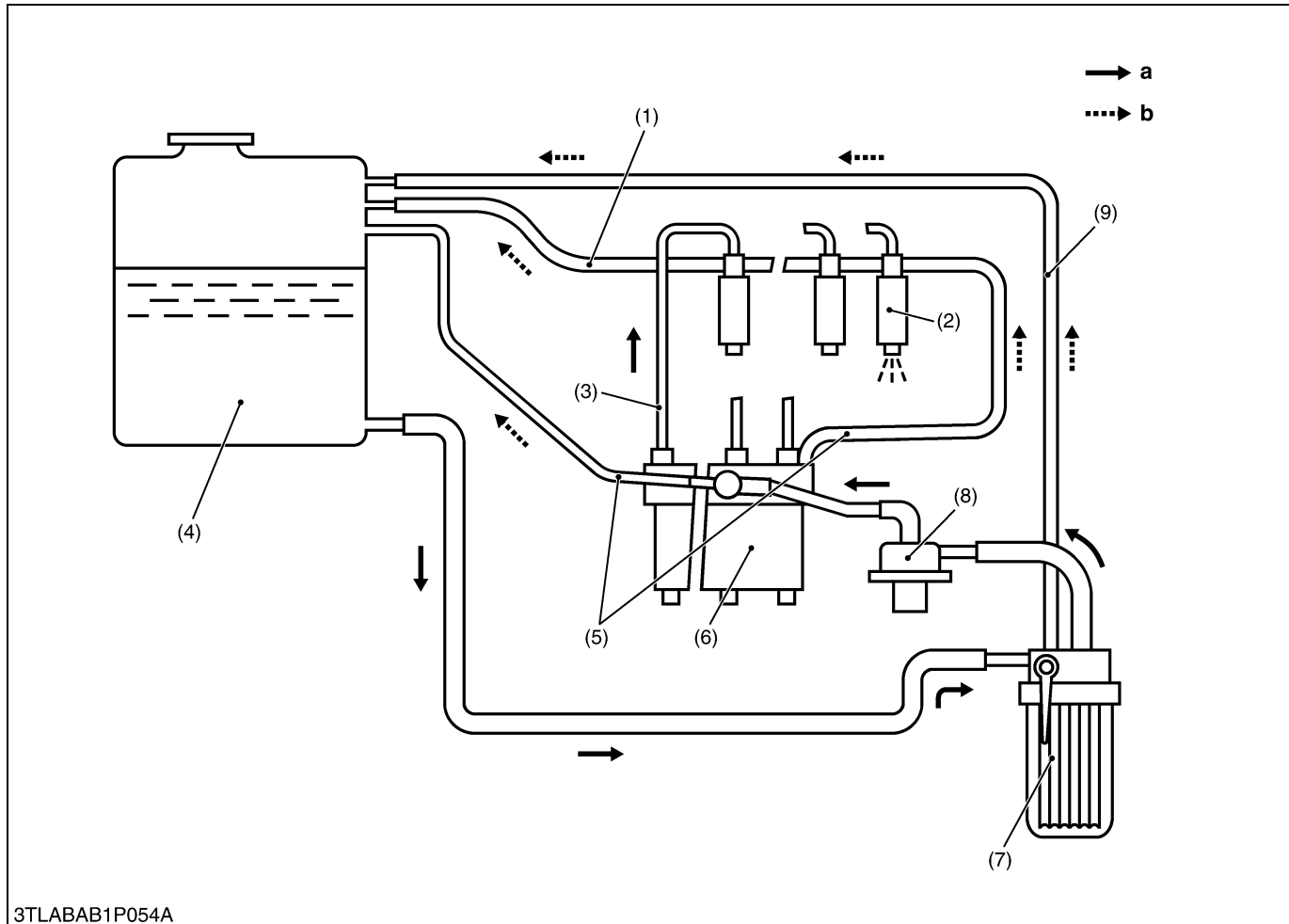

- |                        |                                  |                               |                               |
|------------------------|----------------------------------|-------------------------------|-------------------------------|
| (1) Fuel Overflow Pipe | (4) Fuel Tank                    | (7) Fuel Filter               | <b>a : Injected Fuel Flow</b> |
| (2) Injection Nozzle   | (5) Injection Pump Air Vent Pipe | (8) Fuel Feed Pump            | <b>b : Returned Fuel Flow</b> |
| (3) Injection Pipe     | (6) Injection Pump               | (9) Fuel Filter Air Vent Pipe |                               |

The fuel system of this tractor is shown in the diagram above.

Fuel from the tank flows in the passage as shown by the arrows, and is injected from the nozzle via the fuel injection pump. Overflow fuel returns to the tank.

The system includes filters and other concerns to protect it from entrance of air, water and dust.

While the engine is running, fuel is fed into the injection pump (6) by the fuel feed pump (8) after passing through the fuel filter (7). The fuel camshaft actuates the injection pump and force-feeds fuel to the injection nozzle (2) through the injection pipe (3). Fuel is then sprayed through the nozzle into the combustion chamber. The fuel discharged after lubricating and cooling the injection nozzle is returned to the fuel tank (4) automatically through the overflow pipe (1).



### 3. LUBRICATING SYSTEM

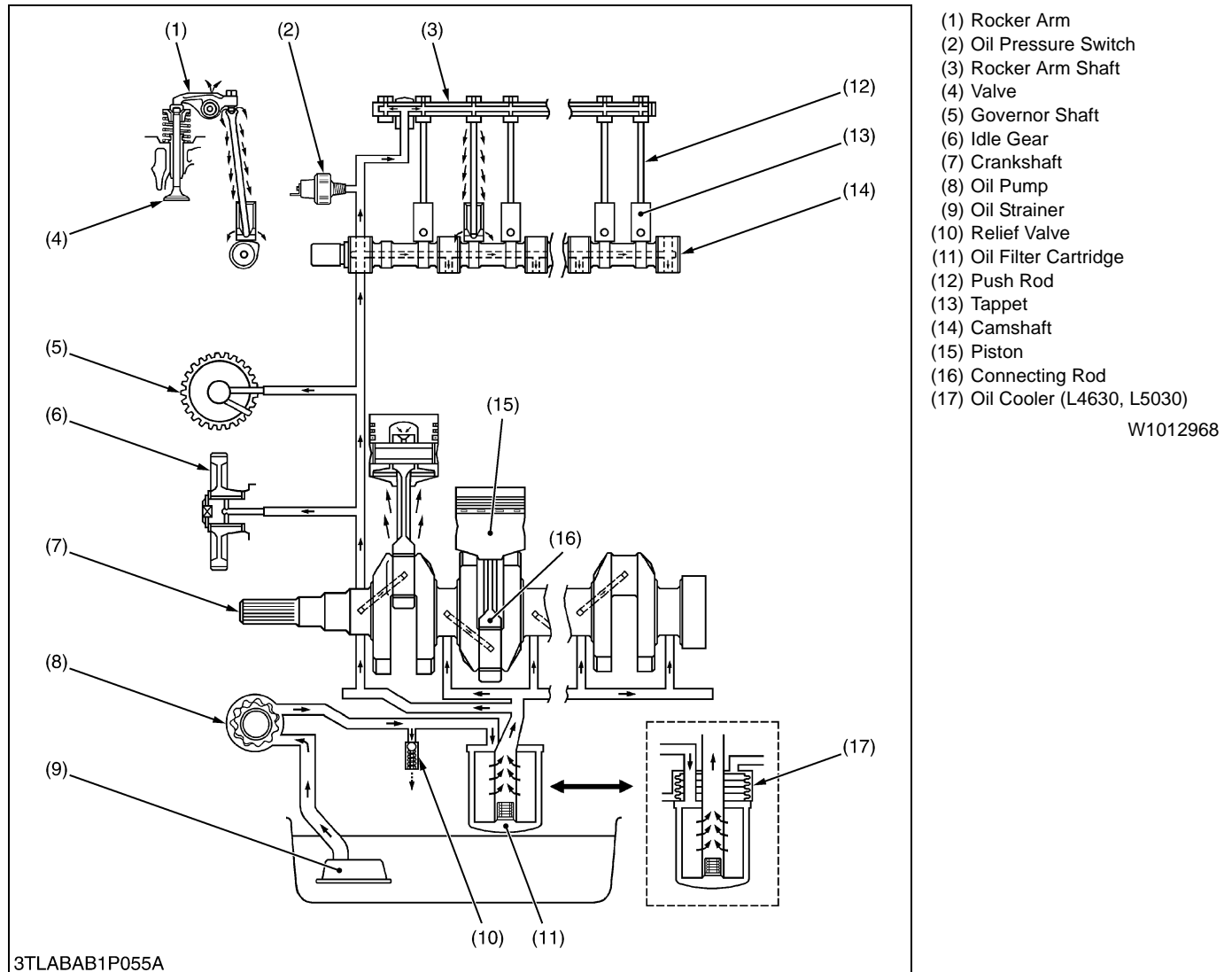

W1012968

A lubricating system consists of an oil strainer (9), oil pump (8), relief valve (10), oil filter cartridge (11), oil cooler (17) and oil pressure switch (2).

The oil pump sucks lubricating oil from the oil pan through the oil strainer and the oil flows down to the oil filter, cartridge where it is further filtered. Then the oil is forced to crankshaft (7), connecting rods (16), idle gear (6), governor shaft (5), camshaft (14) and rocker arm shaft (3) to lubricate each part through the oil gallery.

## 4. COOLING SYSTEM

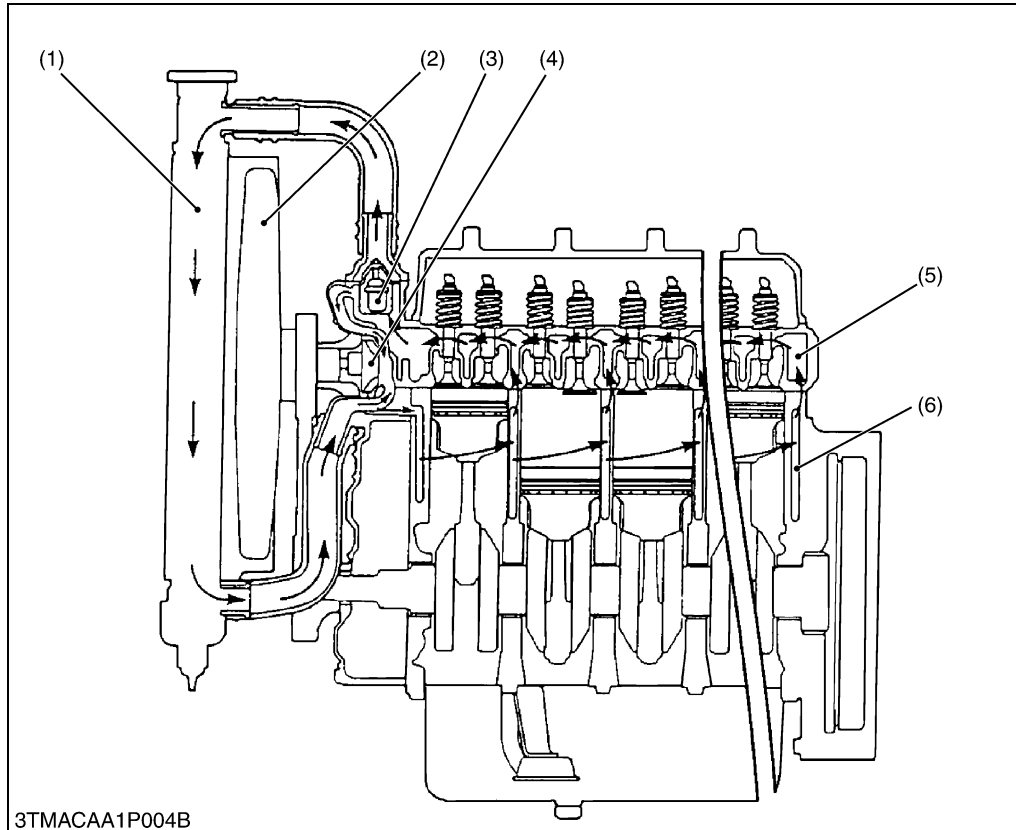

- (1) Radiator
- (2) Cooling Fan
- (3) Thermostat
- (4) Water Pump
- (5) Cylinder Head Water Jacket
- (6) Cylinder Block Water Jacket

W1013006

3TMACAA1P004B

The cooling system consists of a radiator (1), a centrifugal water pump (4), a cooling fan (2) and a thermostat (3).

The water is cooled as it flows through the radiator core, and the cooling air through the radiator core by cooling fan (2).

The water pump receives water from the radiator or from the cylinder head and force it into the cylinder block.

The thermostat (3) opens or closes according to the water temperature. When the water temperature is high, the thermostat (3) opens to allow the water to flow from the cylinder head to the radiator (1). When the water temperature is low, the thermostat close to flow the water only to the water pump (4).

The opening temperature of the thermostat (3) is approx. 71 °C (159.8 °F).

# SERVICING

## CONTENTS

1. TROUBLESHOOTING .....	1-S1
2. SERVICING SPECIFICATIONS .....	1-S4
3. TIGHTENING TORQUES .....	1-S11
4. CHECKING, DISASSEMBLING AND SERVICING.....	1-S12
[1] SEPARATING ENGINE FROM TRACTOR .....	1-S12
[2] ENGINE BODY .....	1-S26
(1) Checking and Adjusting .....	1-S26
(2) Disassembling and Assembling .....	1-S28
(3) Servicing .....	1-S44
[3] LUBRICATING SYSTEM .....	1-S61
(1) Checking .....	1-S61
(2) Servicing .....	1-S61
[4] COOLING SYSTEM.....	1-S62
(1) Checking and Adjusting .....	1-S62
[5] FUEL SYSTEM .....	1-S64
(1) Checking and Adjusting .....	1-S64

# 1. TROUBLESHOOTING

Symptom	Probable Cause	Solution	Reference Page
<b>Engine Does Not Start</b>	<ul style="list-style-type: none"> <li>No fuel</li> <li>Air in the fuel system</li> <li>Water in the fuel system</li> <li>Fuel pipe clogged</li> <li>Fuel filter clogged</li> <li>Excessively high viscosity of fuel or engine oil at low temperature</li> <li>Fuel with low cetane number</li> <li>Fuel leak due to loose injection pipe retaining nut</li> <li>Incorrect injection timing</li> <li>Fuel camshaft worn</li> <li>Injection nozzle clogged</li> <li>Injection pump malfunctioning</li> <li>Seizure of crankshaft, camshaft, piston, cylinder or bearing</li> <li>Compression leak from cylinder</li> <li>Improper valve timing</li> <li>Piston ring and cylinder worn</li> <li>Excessive valve clearance</li> </ul>	Replenish fuel Bleed Change fuel and repair or replace fuel system Clean Change Use the specified fuel or engine oil Use the specified fuel Tighten nut  Adjust Replace Clean Repair or replace Repair or replace  Replace head gasket, tighten cylinder head screw, glow plug and nozzle holder  Correct or replace timing gear Replace Adjust	G-7, 8 G-34 – – G-31 G-7, 8 G-7, 8 1-S29  1-S64 1-S37 – 1-S32 1-S37, S39, S42 1-S29, S30  1-S36  1-S39 1-S27
<b>Starter Does Not Run</b>	<ul style="list-style-type: none"> <li>Battery discharged</li> <li>Starter malfunctioning</li> <li>Main switch malfunctioning</li> <li>Safety switches improperly adjusted or defective</li> <li>Starter relay defective</li> <li>Wiring disconnected</li> <li>Electronic instrument panel connector disconnected</li> </ul>	Charge Repair or replace Repair or replace Repair or replace  Replace Connect Connect	G-25 9-S41 9-S33, 34 9-S35  9-S37 – –
<b>Engine Revolution Is Not Smooth</b>	<ul style="list-style-type: none"> <li>Fuel filter clogged or dirty</li> <li>Air cleaner clogged</li> <li>Fuel leak due to loose injection pipe retaining nut</li> <li>Injection pump malfunctioning</li> <li>Incorrect nozzle injection pressure</li> <li>Injection nozzle stuck or clogged</li> <li>Governor malfunctioning</li> </ul>	Change Clean or change Tighten nut  Repair or replace Adjust Repair or replace Repair	G-31 G-22 1-S29  1-S32 1-S65 1-S29 –
<b>Either White or Blue Exhaust Gas Is Observe</b>	<ul style="list-style-type: none"> <li>Excessive engine oil</li> <li>Piston ring and cylinder worn or stuck</li> <li>Incorrect injection timing</li> <li>Deficient compression</li> </ul>	Reduce to the specified level Repair or replace Adjust Adjust top clearance	G-7, 8  1-S40 1-S64 1-S28

W1014322

Symptom	Probable Cause	Solution	Reference Page
<b>Either Black or Dark Gray Exhaust Gas Is Observe</b>	<ul style="list-style-type: none"> <li>• Overload</li> <li>• Low grade fuel used</li> <li>• Fuel filter clogged</li> <li>• Air cleaner clogged</li> <li>• Deficient nozzle injection</li> </ul>	Lessen the load Use the specified fuel Change Clean or change Repair or replace the nozzle	– G-7, 8 G-31 G-22 1-S29
<b>Deficient Output</b>	<ul style="list-style-type: none"> <li>• Incorrect injection timing</li> <li>• Engine's moving parts seem to be seizing</li> <li>• Uneven fuel injection</li> <li>• Deficient nozzle injection</li> <li>• Compression leak</li> </ul>	Adjust Repair or replace Repair or replace the injection pump Repair or replace the nozzle Replace head gasket, tighten cylinder head bolt, glow plug and nozzle holder	1-S64 – 1-S32 1-S29, S65 1-S29, S30
<b>Excessive Lubricant Oil Consumption</b>	<ul style="list-style-type: none"> <li>• Piston ring's gap facing the same direction</li> <li>• Oil ring worn or stuck</li> <li>• Piston ring groove worn</li> <li>• Valve stem and guide worn</li> <li>• Oil leaking due to defective seals or packing</li> </ul>	Shift ring gap direction Replace Replace the piston Replace Replace	1-S40 1-S40 1-S39, S40 1-S31 –
<b>Fuel Mixed Into Lubricant Oil</b>	<ul style="list-style-type: none"> <li>• Injection pump's plunger worn</li> <li>• Deficient nozzle injection</li> <li>• Injection pump broken</li> </ul>	Replace pump element or pump Repair or replace the nozzle Replace	1-S32 1-S29, S65 1-S32
<b>Water Mixed Into Lubricant Oil</b>	<ul style="list-style-type: none"> <li>• Head gasket defective</li> <li>• Cylinder block or cylinder head flawed</li> </ul>	Replace Replace	1-S30 1-S30
<b>Low Oil Pressure</b>	<ul style="list-style-type: none"> <li>• Engine oil insufficient</li> <li>• Oil straight clogged</li> <li>• Relief valve stuck with dirt</li> <li>• Relief valve spring weaken or broken</li> <li>• Excessive oil clearance of crankshaft bearing</li> <li>• Excessive oil clearance of crankpin bearing</li> <li>• Excessive oil clearance of rocker arm</li> <li>• Oil passage clogged</li> <li>• Different type of oil</li> <li>• Oil Pump defective</li> </ul>	Replenish Clean Clean Replace Replace Replace Replace Clean Use the specified type of oil Repair or replace	G-7, 8 1-S38 – – 1-S43 1-S43 1-S30 – G-7, 8 1-S37
<b>High Oil Pressure</b>	<ul style="list-style-type: none"> <li>• Difference type oil</li> <li>• Relief valve defective</li> </ul>	Use the specified type of oil Replace	G-7, 8 –

W1014322

Symptom	Probable Cause	Solution	Reference Page
<b>Engine Overheated</b>	• Engine oil insufficient	Replenish	G-7, 8
	• Fan belt broken or elongated	Change or adjust	G-23
	• Coolant insufficient	Replenish	–
	• Radiator net and radiator fin clogged with dust	Clean	–
	• Inside of radiator corroded	Clean or replace	–
	• Coolant flow route corroded	Clean or replace	G-27
	• Radiator cap defective	Replace	1-S63
	• Overload running	Loosen the load	–
	• Head gasket defective	Replace	1-S30
	• Incorrect injection timing	Adjust	1-S64
	• Unsuitable fuel used	Use the specified fuel	G-7, 8

W1014322

## 2. SERVICING SPECIFICATIONS

### ENGINE BODY

Item		Factory Specification	Allowable Limit
Cylinder Head Surface	Flatness	–	0.05 mm / 500 mm 0.0020 in. / 19.69 in.
Compression Pressure (When Cranking with Starting Motor)		3.53 to 4.02 MPa / 290 min <sup>-1</sup> (rpm) 36 to 41 kgf/cm <sup>2</sup> / 290 min <sup>-1</sup> (rpm) 512 to 583 psi / 290 min <sup>-1</sup> (rpm)	2.55 MPa / 290 min <sup>-1</sup> (rpm) 26 kgf/cm <sup>2</sup> / 290 min <sup>-1</sup> (rpm) 370 psi / 290 min <sup>-1</sup> (rpm)
Difference among Cylinders		–	10 % or less
Top Clearance		0.55 to 0.70 mm 0.0217 to 0.0276 in.	–
Valve Clearance (When Cold)		0.18 to 0.22 mm 0.0071 to 0.0087 in.	–
Valve Seat	Width (Intake)	2.12 mm 0.0835 in.	–
	Width (Exhaust)	2.12 mm 0.0835 in.	–
Valve Seat	Angle (Intake)	1.047 rad 60 °	–
	Angle (Exhaust)	0.785 rad 45 °	–
Valve Face	Angle (Intake)	1.047 rad 60 °	–
	Angle (Exhaust)	0.785 rad 45 °	–
Valve Stem to Valve Guide	Clearance	0.040 to 0.070 mm 0.00157 to 0.00276 in.	0.1 mm 0.0039 in.
Valve Stem	O.D.	7.960 to 7.975 mm 0.31339 to 0.31398 in.	–
Valve Guide	I.D.	8.015 to 8.030 mm 0.31555 to 0.31614 in.	–
Valve Recessing	Protrusion	0.05 mm 0.0020 in.	–
	Recessing	0.15 mm 0.0059 in.	0.4 mm 0.0157 in.

W1013874

**ENGINE BODY (Continued)**

Item			Factory Specification	Allowable Limit
Valve Timing (Intake Valve)	D1503-M	Open	0.14 rad (8 °) before T.D.C.	–
		Close	0.35 rad (20 °) after B.D.C.	–
	D1703-M D1803-M V2203-M V2403-M	Open	0.21 rad (12 °) before T.D.C.	–
		Close	0.63 rad (36 °) after B.D.C.	–
Valve Timing (Exhaust Valve)	D1503-M	Open	1.05 rad (60 °) before B.D.C.	–
		Close	0.21 rad (12 °) after T.D.C.	–
	D1703-M D1803-M V2203-M V2403-M	Open	1.00 rad (57 °) before B.D.C.	–
		Close	0.21 rad (12 °) after T.D.C.	–
Valve Spring		Free Length	41.7 to 42.2 mm 1.6417 to 1.6614 in.	41.2 mm 1.6220 in.
		Setting Load / Setting Length	117.6 N / 35.0 mm 12.0 kgf / 35.0 mm 26.4 lbs / 1.3780 in.	100.0 N / 35.0 mm 10.2 kgf / 35.0 mm 22.5 lbs / 1.3780 in.
		Tilt	–	1.0 mm 0.039 in.
Rocker Arm Shaft to Rocker Arm		Clearance	0.016 to 0.045 mm 0.00063 to 0.00177 in.	0.1 mm 0.0039 in.
		Rocker Arm Shaft O.D.	13.973 to 13.984 mm 0.55012 to 0.55055 in.	–
		Rocker Arm I.D.	14.000 to 14.018 mm 0.55118 to 0.55189 in.	–
Push Rod		Alignment	–	0.25 mm 0.0098 in.
Tappet to Tappet Guide		Clearance	0.020 to 0.062 mm 0.00079 to 0.00244 in.	0.07 mm 0.0028 in.
		Tappet O.D.	23.959 to 23.980 mm 0.94327 to 0.94410 in.	–
		Tappet Guide I.D.	24.000 to 24.021 mm 0.94488 to 0.94571 in.	–

W1013874



**ENGINE BODY (Continued)**

Item		Factory Specification	Allowable Limit	
Timing Gear Crank Gear to Idle Gear	Backlash	0.0415 to 0.1122 mm 0.00163 to 0.00442 in.	0.15 mm 0.0059 in.	
	Idle Gear to Cam Gear	0.0415 to 0.1154 mm 0.00163 to 0.00454 in.	0.15 mm 0.0059 in.	
Idle Gear to Injection Pump Gear	Backlash	0.0415 to 0.1154 mm 0.00163 to 0.00454 in.	0.15 mm 0.0059 in.	
Crank Gear to Oil Pump Gear	Backlash	0.0415 to 0.1090 mm 0.00163 to 0.00429 in.	0.15 mm 0.0059 in.	
Idle Gear to Balancer Gear (Balancer Model Only)	Backlash (Intake side)	0.0350 to 0.1160 mm 0.00138 to 0.00457 in.	0.15 mm 0.0059 in.	
	Backlash (Exhaust side)	0.0350 to 0.1160 mm 0.00138 to 0.00457 in.	0.15 mm 0.0059 in.	
Idle Gear	Side Clearance	0.12 to 0.48 mm 0.0047 to 0.0189 in.	0.9 mm 0.0354 in.	
Idle Gear Shaft to Idle Gear Bushing	Clearance	0.025 to 0.066 mm 0.00098 to 0.00260 in.	0.1 mm 0.0039 in.	
	Idle Gear Shaft	O.D.	37.959 to 37.975 mm 1.49445 to 1.49508 in.	–
	Idle Gear Bushing	I.D.	38.000 to 38.025 mm 1.49606 to 1.49704 in.	–
Camshaft	Side Clearance	0.07 to 0.22 mm 0.0028 to 0.0087 in.	0.3 mm 0.0118 in.	
Camshaft	Alignment	–	0.01 mm 0.0004 in.	
Cam	Height (Intake / Exhaust)	33.90 mm 1.3346 in.	33.85 mm 1.3327 in.	
Camshaft Journal to Cylinder Block Bore	Clearance	0.050 to 0.091 mm 0.00197 to 0.00358 in.	0.15 mm 0.0059 in.	
	Camshaft Journal	O.D.	39.934 to 39.950 mm 1.57221 to 1.57284 in.	–
	Cylinder Block Bore	I.D.	40.000 to 40.025 mm 1.57480 to 1.57579 in.	–
Balancer Shaft (Balancer Model Only)	Side Clearance	0.07 to 0.22 mm 0.0028 to 0.0087 in.	0.3 mm 0.0118 in.	
Balancer Shaft Journal 1 to Balancer Shaft Bearing 1 (Balancer Model Only)	Clearance	0.030 to 0.111 mm 0.00118 to 0.00437 in.	0.2 mm 0.0079 in.	
	Balancer Shaft Journal 1	O.D.	43.934 to 43.950 mm 1.72968 to 1.73031 in.	–
	Balancer Shaft Bearing 1	I.D.	43.980 to 44.045 mm 1.73149 to 1.73405 in.	–

W1013874

**ENGINE BODY (Continued)**

Item			Factory Specification	Allowable Limit	
Balancer Shaft Journal 2 to Balancer Shaft Bearing 2 (Balancer Model Only)		Clearance	0.030 to 0.111 mm 0.00118 to 0.00437 in.	0.2 mm 0.0079 in.	
	Balancer Shaft Journal 2	O.D.	41.934 to 41.950 mm 1.65094 to 1.65157 in.	–	
	Balancer Shaft Bearing 2	I.D.	41.980 to 42.045 mm 1.65275 to 1.65531 in.	–	
Balancer Shaft Journal 3 to Balancer Shaft Bearing 3 (Balancer Model Only)		Clearance	0.020 to 0.094 mm 0.00079 to 0.00370 in.	0.2 mm 0.0079 in.	
	Balancer Shaft Journal 3	O.D.	21.947 to 21.960 mm 0.86405 to 0.86456 in.	–	
	Balancer Shaft Bearing 3	I.D.	21.980 to 22.041 mm 0.86535 to 0.86775 in.	–	
Piston Pin Bore		I.D.	25.000 to 25.013 mm 0.98425 to 0.98476 in.	25.05 mm 0.9862 in.	
Second Ring to Ring Groove	D1503-M	Clearance	0.093 to 0.120 mm 0.0037 to 0.0047 in.	0.2 mm 0.0079 in.	
	D1703-M D1803-M V2203-M V2403-M		0.093 to 0.128 mm 0.0037 to 0.0050 in.	0.2 mm 0.0079 in.	
Oil Ring to Ring Groove			Clearance	0.020 to 0.060 mm 0.0008 to 0.0021 in.	0.15 mm 0.0059 in.
Top Ring	D1503-M		Ring Gap	0.20 to 0.35 mm 0.0079 to 0.0138 in.	1.25 mm 0.0492 in.
	D1703-M D1803-M V2203-M V2403-M		0.20 to 0.40 mm 0.0079 to 0.0157 in.	1.25 mm 0.0492 in.	
Second Ring		Ring Gap	0.30 to 0.45 mm 0.0118 to 0.0177 in.	1.25 mm 0.0492 in.	
Oil Ring		Ring Gap	0.25 to 0.45 mm 0.0098 to 0.0177 in.	1.25 mm 0.0492 in.	
Connecting Rod		Alignment	–	0.05 mm 0.0020 in.	
Piston Pin to Small End Bushing		Clearance	0.014 to 0.038 mm 0.00055 to 0.00150 in.	0.15 mm 0.0059 in.	
	Piston Pin	O.D.	25.002 to 25.011 mm 0.98433 to 0.98468 in.	–	
	Small End Bushing	I.D.	25.025 to 25.040 mm 0.98523 to 0.98582 in.	–	
Crankshaft		Alignment	–	0.02 mm 0.00079 in.	

W1013874

**ENGINE BODY (Continued)**

Item		Factory Specification	Allowable Limit
Crankshaft Journal to Crankshaft Bearing 1		Oil Clearance	0.040 to 0.118 mm 0.00157 to 0.00465 in.
Crankshaft Journal	D1503-M D1703-M V2203-M	O.D.	51.921 to 51.940 mm 2.04413 to 2.04488 in.
Crankshaft Bearing 1	D1803-M V2403-M		59.921 to 59.940 mm 2.35909 to 2.35984 in.
	D1503-M D1703-M V2203-M	I.D.	51.980 to 52.039 mm 2.04646 to 2.04878 in.
	D1803-M V2403-M		59.980 to 60.039 mm 2.36142 to 2.36374 in.
Crankshaft Journal to Crankshaft Bearing 2		Oil Clearance	0.040 to 0.104 mm 0.00157 to 0.00409 in.
Crankshaft Journal	D1503-M D1703-M V2203-M	O.D.	51.921 to 51.940 mm 2.04413 to 2.04488 in.
Crankshaft Bearing 2	D1803-M V2403-M		59.921 to 59.940 mm 2.35909 to 2.35984 in.
	D1503-M D1703-M V2203-M	I.D.	51.980 to 52.025 mm 2.04646 to 2.04823 in.
	D1803-M V2403-M		59.980 to 60.025 mm 2.36142 to 2.36318 in.
Crankpin to Crankpin Bearing		Oil Clearance	0.025 to 0.087 mm 0.00098 to 0.00343 in.
Crankpin		O.D.	46.959 to 46.975 mm 1.84878 to 1.84941 in.
Crankpin Bearing		I.D.	47.000 to 47.046 mm 1.85039 to 1.85220 in.
Crankshaft	D1503-M D1703-M V2203-M	Side Clearance	0.15 to 0.35 mm 0.0059 to 0.0138 in.
	D1803-M V2403-M		0.15 to 0.31 mm 0.0059 to 0.0122 in.
Crankshaft Sleeve		Wear	—
			0.1 mm 0.0039 in.

W1029676

**ENGINE BODY (Continued)**

Item			Factory Specification	Allowable Limit
Cylinder Bore [Standard]	D1503-M	I.D.	83.000 to 83.022 mm 3.26772 to 3.26858 in.	+ 0.15 mm + 0.0059 in.
	D1703-M D1803-M V2203-M V2403-M		87.000 to 87.022 mm 3.42519 to 3.42606 in.	+ 0.15 mm + 0.0059 in.
[Oversize]	D1503-M	I.D.	83.250 to 83.272 mm 3.27756 to 3.27843 in.	+ 0.15 mm + 0.0059 in.
	D1703-M D1803-M V2203-M V2403-M		87.250 to 87.272 mm 3.43503 to 3.43590 in.	+ 0.15 mm + 0.0059 in.

W1013874

**LUBRICATING SYSTEM**

Engine Oil Pressure	At Idle Speed	98 kPa or more 1.0 kgf/cm <sup>2</sup> or more 14 psi or more	49 kPa 0.5 kgf/cm <sup>2</sup> 7 psi
	At Rated Speed	294 to 441 kPa 3.0 to 4.5 kgf/cm <sup>2</sup> 43 to 64 psi	245 kPa 2.5 kgf/cm <sup>2</sup> 36 psi
Engine Oil Pressure Switch	Working Pressure	49 kPa 0.5 kgf/cm <sup>2</sup> 7 psi	—
Inner Rotor to Outer Rotor	Clearance	0.03 to 0.14 mm 0.0012 to 0.0055 in.	0.2 mm 0.0079 in.
Outer Rotor to Pump Body	Clearance	0.11 to 0.19 mm 0.0043 to 0.0075 in.	0.25 mm 0.0098 in.
Inner Rotor to Cover	Clearance	0.105 to 0.150 mm 0.00413 to 0.00591 in.	0.2 mm 0.0079 in.

W1013973

**COOLING SYSTEM**

Item		Factory Specification	Allowable Limit
Fan Belt	Tension	7.0 to 9.0 mm (0.28 to 0.35 in.) deflection at 98 N (10 kgf, 22 lbs) of force	–
Thermostat	Valve Opening Temperature (At Beginning)	69.5 to 72.5 °C 157.1 to 162.5 °F	–
	Valve Opening Temperature (Opened Completely)	85 °C 185 °F	–
Radiator	Water Tightness	No leaks at 137 kPa 1.4 kgf/cm <sup>2</sup> 20 psi	–
Radiator Cap	Pressure Falling Time	10 seconds or more for pressure falling from 88 to 59 kPa from 0.9 to 0.6 kgf/cm <sup>2</sup> from 13 to 9 psi	–

W1013874

**FUEL SYSTEM**

Injection Pump	Injection Timing	0.297 to 0.331 rad (17 to 19 °) before T.D.C.	–
Pump Element	Fuel Tightness	–	14.7 MPa 150 kgf/cm <sup>2</sup> 2133 psi
Delivery Valve	Fuel Tightness	10 seconds or more for pressure falling from 14.7 to 13.7 MPa from 150 to 140 kgf/cm <sup>2</sup> from 2133 to 1990 psi	5 seconds for pressure falling from 14.7 to 13.7 MPa from 150 to 140 kgf/cm <sup>2</sup> from 2133 to 1990 psi
Injection Nozzle	Injection Pressure	13.73 to 14.71 MPa 140 to 150 kgf/cm <sup>2</sup> 1991 to 2133 psi	–
Injection Nozzle Valve Seat	Valve Seat Tightness	When the pressure is 12.75 MPa (130 kgf/cm <sup>2</sup> , 1849 psi), the valve seat must be fuel tightness.	–

W1013973

### 3. TIGHTENING TORQUES

Tightening torques of screws, bolts and nuts on the table below are especially specified.  
(For general use screws, bolts and nuts : See page G-10.)

Item	N-m	kgf-m	ft-lbs
Lower frame mounting screw	260 to 304	26.5 to 31.0	192 to 224
ROPS lower connector mounting screw	103 to 118	10.5 to 12.0	75.9 to 86.8
ROPS plate mounting screw (M14 × 40)	138 to 147	14.0 to 15.0	102 to 108
(M14 × 30)	167 to 196	17.0 to 20.0	123 to 145
Step mounting bolt and nut	124 to 147	12.6 to 15.0	91.1 to 108
Floor seat mounting bolt and nut	196 to 225	20 to 23	145 to 166
Compressor mounting screw	24.5 to 29.4	2.5 to 3.0	18.1 to 21.7
Muffler mounting screw	31.4 to 37.2	3.2 to 3.8	23.1 to 27.5
Cabin mounting bolt and nut	124 to 147	12.6 to 15.0	91.1 to 108
Joint bolt for main delivery pipe 1	49 to 69	5.0 to 7.0	36.1 to 50.6
Joint bolt for PTO delivery pipe	34 to 39	3.5 to 4.0	25.3 to 28.9
Joint bolt for oil cooler pipe	34 to 39	3.5 to 4.0	25.3 to 28.9
Engine and clutch housing mounting screw and nut	77.5 to 90.2	7.9 to 9.2	57.1 to 66.5
Engine and clutch housing mounting stud bolt	39.2 to 49.0	4.0 to 5.0	28.9 to 36.2
Joint bolt for power steering delivery pipe	39.2 to 49.0	4.0 to 5.0	28.9 to 36.1
Cap nut of power steering delivery pipe	49.0 to 58.8	5.0 to 6.0	36.1 to 43.4
Front axle frame mounting screw (7T)	77.5 to 90.2	7.9 to 9.2	57.1 to 66.5
(9T)	102.9 to 117.6	10.5 to 12.0	76.0 to 86.8
Alternator mounting screw (M10)	39.2 to 44.1	4.0 to 4.5	28.9 to 32.5
Tension adjusting screw (M8)	17.6 to 20.6	1.8 to 2.1	13.0 to 15.2
Clutch mounting screw	23.5 to 27.5	2.4 to 2.8	17.4 to 20.3

W1012736

Item	Size x Pitch	N-m	kgf-m	ft-lbs
* Cylinder head screws	M11 × 1.25	93.1 to 98.0	9.5 to 10.0	68.7 to 72.3
Cylinder head cover screw	M6 × 1.0	6.9 to 11.3	0.7 to 1.15	5.1 to 8.32
Injection pipe retaining nuts	M12 × 1.5	24.5 to 34.3	2.5 to 3.5	18.1 to 25.3
Nozzle holder assembly	M20 × 2.0	49.0 to 68.6	5.0 to 7.0	36.2 to 50.6
Overflow pipe assembly retaining nuts	–	19.6 to 24.5	2.0 to 2.5	14.5 to 18.1
Glow plugs	M10 × 1.25	19.6 to 24.5	2.0 to 2.5	17.4 to 20.3
* Rocker arm bracket nut	M8 × 1.25	23.5 to 27.5	2.4 to 2.8	14.5 to 18.1
Hi-idling body	–	44.1 to 49.0	4.5 to 5.0	32.6 to 36.3
Fan drive pulley mounting nut	–	137.3 to 156.9	14.0 to 16.0	101.3 to 115.7
Camshaft set bolt	M8 × 1.25	23.5 to 27.5	2.4 to 2.8	17.4 to 20.3
Balancer shaft set bolt	M8 × 1.25	23.5 to 27.5	2.4 to 2.8	17.4 to 20.3
* Connecting rod screws	M8 × 1.0	44.1 to 49.0	4.5 to 5.0	32.5 to 36.2
* Flywheel screws	M12 × 1.25	98.0 to 107.8	10.0 to 11.0	72.3 to 79.5
* Bearing case cover screws	M8 × 1.25	23.5 to 27.5	2.4 to 2.8	17.4 to 20.3
* Main bearing case screws 2	M10 × 1.25	68.6 to 73.5	7.0 to 7.5	50.6 to 54.2
* Main bearing case screws 1	M9 × 1.25	46.1 to 50.9	4.7 to 5.2	34.0 to 37.6

#### ■ NOTE

- For \* marked screws, bolts and nuts on the table, apply engine oil to their threads and seats before tightening.
- The letter “M” in Size x Pitch means that the screw, bolt or nut dimension stands for metric. The size is the nominal outside diameter in mm of the threads. The pitch is the nominal distance in mm between two threads.

W1013236

## 4. CHECKING, DISASSEMBLING AND SERVICING

### [1] SEPARATING ENGINE FROM TRACTOR

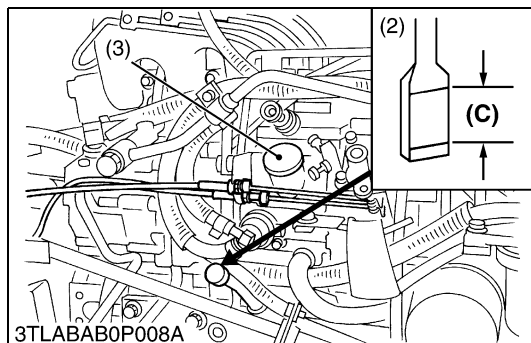
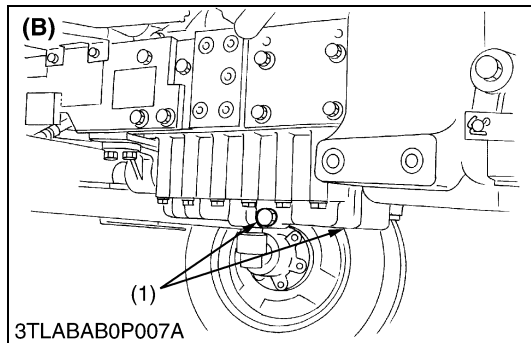
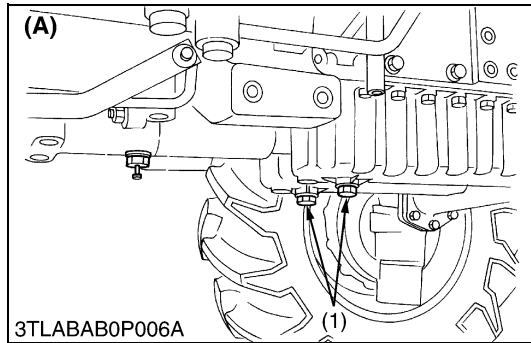

#### Draining Engine Oil

1. Start and warm up the engine for approx. 5 minutes.
2. Place an oil pan underneath the engine.
3. Remove the drain plugs (1) to drain oil.
4. Screw in the drain plugs (1).

#### (When refilling)

- Fill the engine oil up to the upper line on the dipstick (2).

#### ■ IMPORTANT

- **Never mix two different type of oil.**
- **Use the proper SAE Engine Oil according to ambient temperature.**

Refer to "LUBRICANTS, FUEL AND COOLANT". (See page G-7, 8.)

Engine oil capacity	L3130 L3430	5.7 L 6.0 U.S.qts 5.0 Imp.qts
	L3830	6.7 L 7.1 U.S.qts 5.9 Imp.qts
	L4630 L5030	8.2 L 8.7 U.S.qts 7.2 Imp.qts

- (1) Drain Plug  
(2) Dipstick  
(3) Oil Inlet Plug

(A) L3130, L3430, L4630, L5030

(B) L3830

(C) Oil level is acceptable within this range.

W1013940

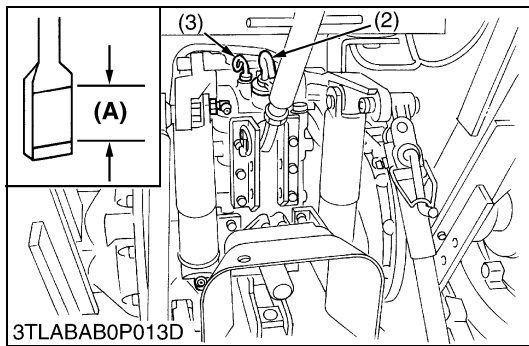
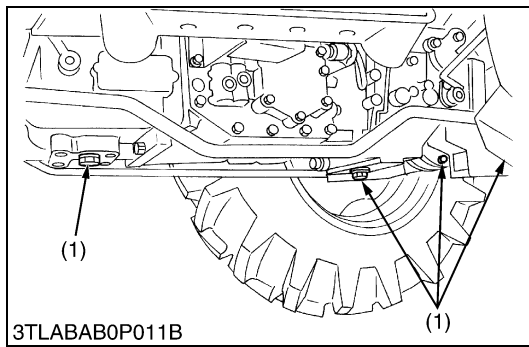

### Draining the Transmission Fluid

1. Place oil pans underneath the transmission case.
2. Remove the drain plugs (1).
3. Drain the transmission fluid.
4. Reinstall the drain plugs (1).

### (When refilling)

- Fill up from filling port after removing the filling plug (2) until reaching the upper notch on the dipstick (3).
- After running the engine for few minutes, stop it and check the oil level again, add the fluid to prescribed level if it is not correct level.

Transmission fluid capacity	L3130 L3430	42 L 11.1 U.S.gals 9.2 Imp.gals
	L3830 L4630	43 L 11.4 U.S.gals 9.5 Imp.gals
	L5030	45 L 11.9 U.S.gals 9.9 Imp.gals

### ■ IMPORTANT

- **Use only KUBOTA SUPER UDT fluid. Use of other oils may damage the transmission or hydraulic system. Refer to “LUBRICANTS, FUEL AND COOLANT”. (See page G-7, 8.)**
- **Do not mix different brands of fluid together.**

- (1) Drain Plugs  
(2) Filling Plug  
(3) Dipstick

(A) Oil level is acceptable within this range.

W1014221



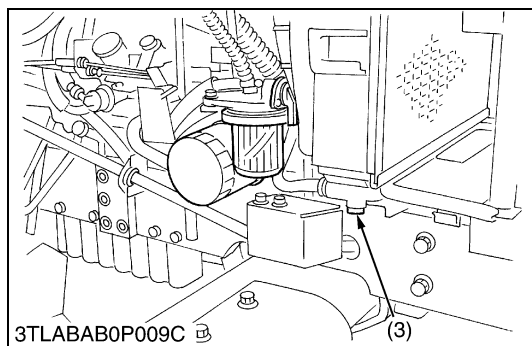
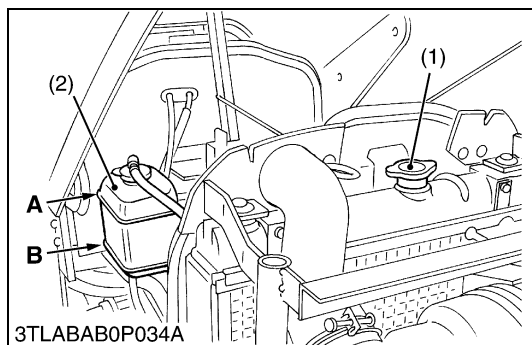

**Draining Coolant**

**CAUTION**

- Never remove the radiator cap until coolant temperature is well below its boiling point. Then loosen cap slightly to the stop to relieve any excess pressure before removing cap completely.

1. Stop the engine and let cool down.
2. Loosen the drain plug (3) to drain the coolant.
3. Remove the radiator cap (1) to completely drain the coolant.
4. After all coolant is drained, retighten the drain plug (3).

**(When refilling)**

- Fill the coolant between the “FULL” and “LOW” marks of recovery tank (2).

Coolant capacity (with recovery tank)	L3130 L3430	6.0 L 6.3 U.S.qts 5.3 Imp.qts
	L3830 (ROPS) L4630 (ROPS)	7.5 L 7.9 U.S.qts 6.6 Imp.qts
	L3830 (CABIN) L4630 (CABIN)	8.7 L 9.2 U.S.qts 7.7 Imp.qts
	L5030	9.2 L 9.7 U.S.qts 8.1 Imp.qts

- (1) Radiator Cap
  - (2) Recovery Tank
  - (3) Drain Plug
- A : FULL**  
**B : LOW**

W10314120

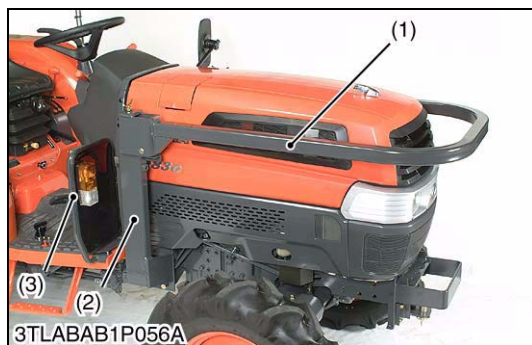

**ROPS (Center ROPS Type)**

1. Remove the upper frame (1) from ROPS lower frame (2).
2. Disconnect the light connectors.
3. Remove the shields (3).
4. Remove the lower frames (2).

**(When reassembling)**

**NOTE**

- Do not firmly tighten all screws until most components are attached.

Tightening torque	Lower frame mounting screw	260 to 304 N-m 26.5 to 31.0 kgf-m 192 to 224 ft-lbs
-------------------	----------------------------	---

- (1) Upper Frame
- (2) Lower Frame
- (3) Shield

W1031307



**Battery, Front Grill, Skirt and Bonnet**

1. Open the bonnet and disconnect the battery negative cable.
2. Disconnect the head light connector and remove the front grill (4).
3. Remove the left and right side skirts (3).
4. Disconnect window washer hoses (2). (Cabin model only.)
5. Remove the bonnet (1).

**NOTE**

- When disconnecting the battery cords, disconnect the negative cord first, when connecting, positive cord first.

- (1) Bonnet
- (2) Window Washer Hose
- (3) Skirt
- (4) Front Grill

W1057856

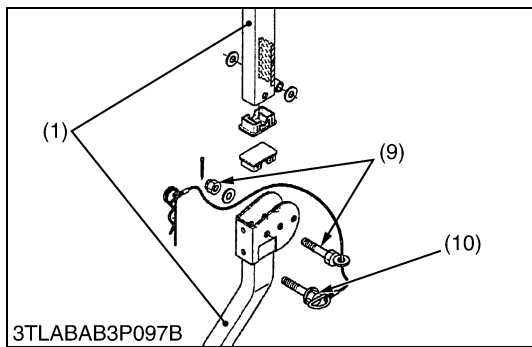
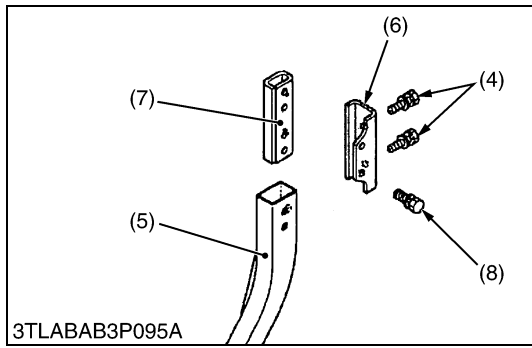
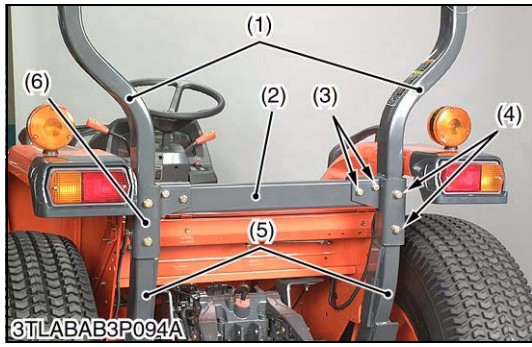

**ROPS**

1. Remove the lower connector (2).
2. Remove the plate mounting screws (4), (8).
3. Remove the upper frame (1) from ROPS lower frame (5).

**(When reassembling)**

■ **NOTE**

- Do not firmly tighten all screws until most components are attached.

Tightening torque	Lower connector mounting screw (3)	103 to 118 N·m 10.5 to 12.0 kgf·m 75.9 to 86.8 ft-lbs
	Plate mounting screw (4)	138 to 147 N·m 14.0 to 15.0 kgf·m 102 to 108 ft-lbs
	Plate mounting screw (8)	167 to 196 N·m 17.0 to 20.0 kgf·m 123 to 145 ft-lbs

**(Reference)**

Tightening torque	Fulcrum bolt and nut (9)	118 to 137 N·m 12.0 to 14.0 kgf·m 86.8 to 102 ft-lbs
-------------------	--------------------------	--

- |                      |                          |
|----------------------|--------------------------|
| (1) Upper Frame      | (6) Plate                |
| (2) Lower Connector  | (7) Connector            |
| (3) Screw (M12 × 65) | (8) Screw (M14 × 30)     |
| (4) Screw (M14 × 40) | (9) Fulcrum Bolt and Nut |
| (5) Lower Frame      | (10) Lock Bolt           |

W1058013

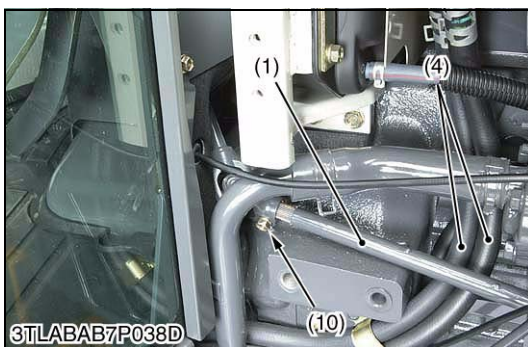
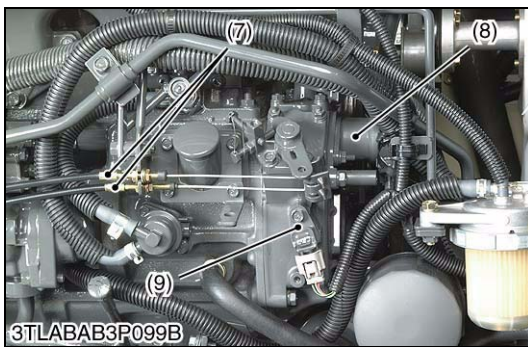
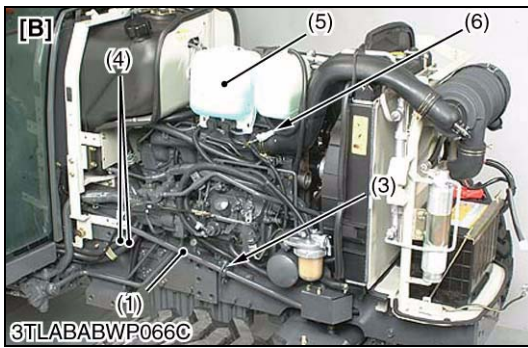
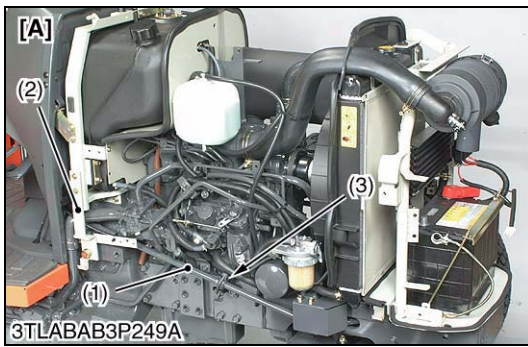

### Steering Joint, Heater Hoses and Electric Wiring

1. Remove the tank frame support (2).
2. Remove the universal joint bolt (10) and steering joint support (3), and then remove the steering joint (2).
3. Disconnect the hand accelerator wire and foot accelerator wire (7). (A feet accelerator is not equipped in HST model.)
4. Disconnect the wiring connectors for engine stop solenoid (8), engine tachometer sensor (9) and glow plug.
5. Disconnect the heater hoses (4), and then reconnect their hoses to make loop. (Cabin model only.)

#### NOTE

- Put a mark to the each heater hose before disconnecting.
6. Disconnect the wiring connector for window washer tank (5) and compressor 1P connector (6). (Cabin model only.)
  7. Disconnect the brake pedal rod.

#### (When reassembling)

- When accelerator wire is installed, adjust the wiring length as hit both the idling speed adjusting bolt and the maximum speed adjusting bolt by lever within the stroke of the accelerator lever.
- Set the steering joint (1) by the joint support (3) so that the steering wheel is turned lightly.
- Be sure to check and adjust the brake pedal free travel. (See page G-18.)

- |                            |                              |
|----------------------------|------------------------------|
| (1) Steering Joint         | (7) Accelerator Wire         |
| (2) Tank Frame Support     | (8) Engine Stop Solenoid     |
| (3) Steering Joint Support | (9) Engine Tachometer Sensor |
| (4) Heater Hose            | (10) Universal Joint Bolt    |
| (5) Window Washer Tank     | <b>[A] ROPS Model</b>        |
| (6) 1P Connector           | <b>[B] Cabin Model</b>       |

W1014863



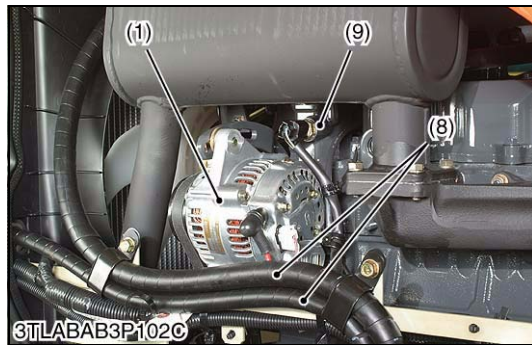
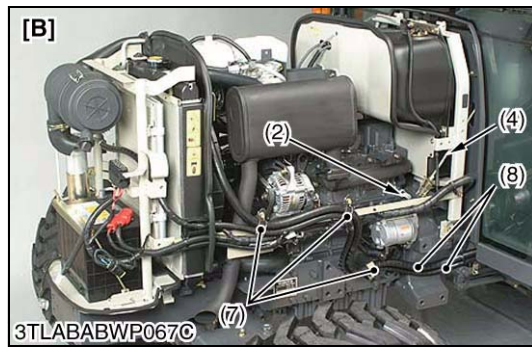
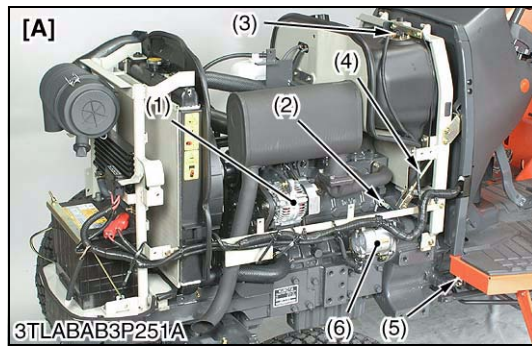

### Clutch Rod, Brake Pedal Rod and Electric Wiring

1. Disconnect the brake pedal rod (5) and clutch rod (4).
2. Disconnect the wiring connectors for alternator (1), coolant temperature sensor (9), oil pressure switch (2), fuel unit (3), starter motor (6) and battery.
3. Remove the clamps and ground earth of wiring harness and collect wiring harness to the step or cabin.
4. Remove the clamps (7) of A/C hoses (8). (Cabin A/C model only.)

### (When reassembling)

- Be sure to check and adjust the clutch and brake pedal free travel. (See page G-18, 24.)

- |                         |                                |
|-------------------------|--------------------------------|
| (1) Alternator          | (7) Clamps                     |
| (2) Oil Pressure Switch | (8) A/C Hoses                  |
| (3) Fuel Unit           | (9) Coolant Temperature Sensor |
| (4) Clutch Rod          |                                |
| (5) Brake Pedal Rod     |                                |
| (6) Starter Motor       |                                |

**[A] ROPS Model**

**[B] Cabin Model**

W1061165

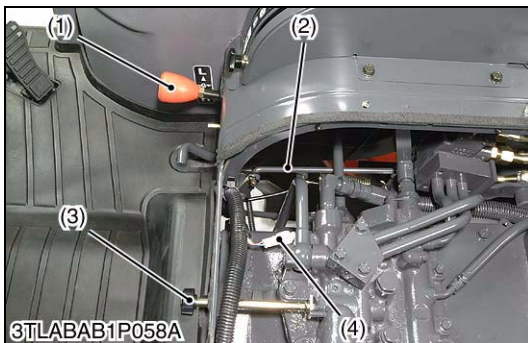
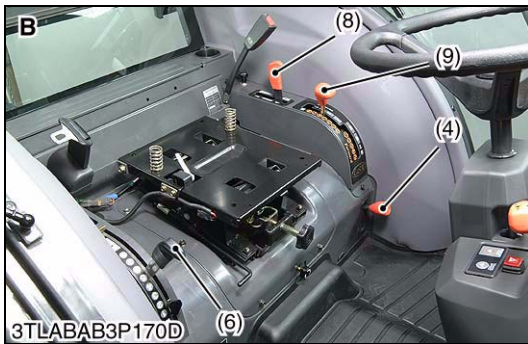
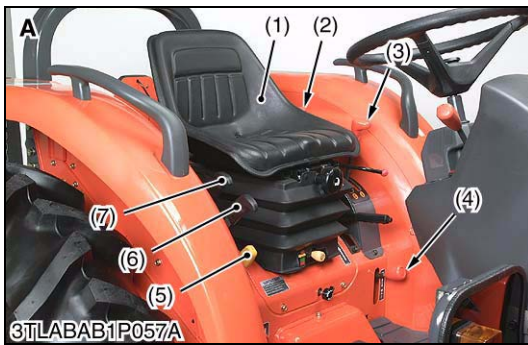

### **Seat, Seat Bracket and Lever Grips**

1. Remove the seat (1) with seat bracket.
2. Remove the front wheel drive lever (4).

#### **(Manual Transmission Model)**

3. Remove the lever grip for position control lever (6), draft control lever (7), range gear shift lever (2), creep shift lever (8), main shift lever (3) and ground PTO lever (5) (if equipped).

#### **(GST Model)**

3. Remove the lever grip for position control lever (6), draft control lever (7), GST lever (9), creep shift lever (8).

#### **(HST Model)**

3. Remove the lever grip for position control lever (6), range gear shift lever (2) and cruise control lever (10).

- |                             |                           |
|-----------------------------|---------------------------|
| (1) Seat                    | (8) Creep Shift Lever     |
| (2) Range Gear Shift Lever  | (9) GST Lever             |
| (3) Main Gear Shift Lever   | (10) Cruise Control Lever |
| (4) Front Wheel Drive Lever |                           |
| (5) Ground PTO Lever        |                           |
| (6) Position Control Lever  |                           |
| (7) Draft Control Lever     |                           |

**A : Manual Transmission Model**

**B : GST Model**

**C : HST Model**

W1061567

### **Differential Lock Rod, Lowering Speed Adjusting Knob and PTO Speed Change Lever (if equipped)**

1. Disconnect the differential lock rod (2).

#### **(Reference)**

- As for location of differential lock rod (2), it is at right side for manual transmission and GST model, and left side for HST model.
2. Remove the lowering speed adjusting knob (3).
  3. Remove the PTO speed change lever (1) (if equipped).
  4. Disconnect the PTO speed sensor (4) (if equipped).

- |                            |                                   |
|----------------------------|-----------------------------------|
| (1) PTO Speed Change Lever | (3) Lowering Speed Adjusting Knob |
| (2) Differential Lock Rod  | (4) PTO Speed Sensor              |

W1063358



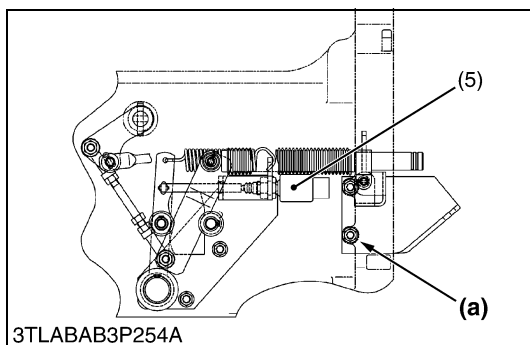
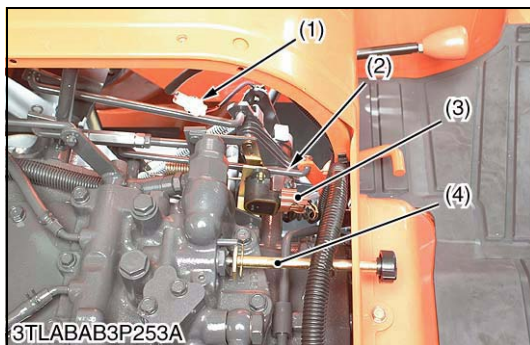
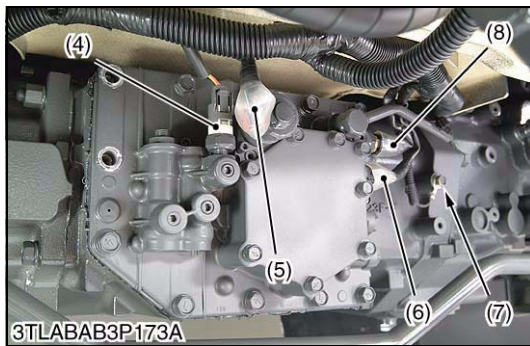
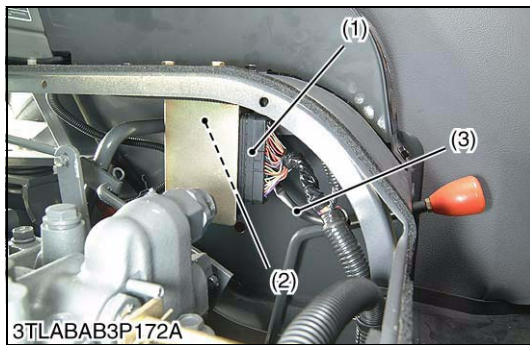

### Electric Connector for GST

1. Disconnect the ECU connector (1).
2. Disconnect the GST lever sensor connector (2).
3. Remove the GST valve cover.
4. Disconnect the pressure switch connector (4), proportional reducing valve connector (5), solenoid valve connector (6), oil temperature sensor connector (8) and ground cables (7).

### (Reference)

- The ground cable (7) is at position where the manual transmission model is the same.

- |  |   |
|--|---|
| (1) ECU Connector                      | (5) Proportional Reducing Valve Connector |
| (2) GST Lever Sensor Connector         | (6) Solenoid Valve Connector              |
| (3) Wiring Harness of GST Lever Sensor | (7) Ground Cable                          |
| (4) Pressure Switch Connector          | (8) Oil Temperature Sensor Connector      |

W1063971

### Electric Connector for HST

1. Remove the lowering speed adjusting knob (4).
2. Disconnect the differential lock rod (2).
3. Disconnect the range gear shift lever sensor connector (3).
4. Disconnect the cruise switch connector (1).
5. Disconnect the HST pedal neutral switch connector (5).
6. Disconnect the ground earth **(a)**.

- |   |  |
|---|--|
| (1) Cruise Switch Connector                 | (4) Lowering Speed Adjusting Knob      |
| (2) Differential Lock Pedal                 | (5) HST Pedal Neutral Switch Connector |
| (3) Range Gear Shift Lever Sensor Connector |  |

**(a) Ground earth is connected here**

W1064315

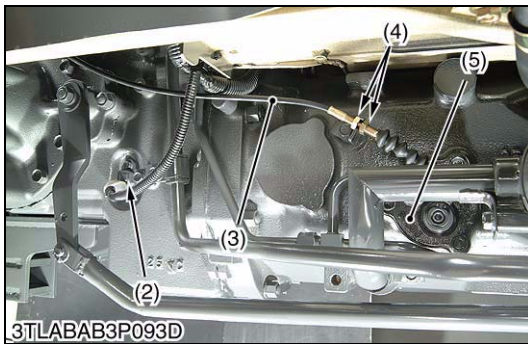
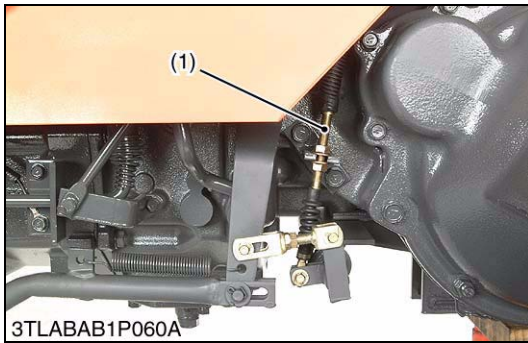

### PTO Shift Wire, Parking Brake Cable and Connector

1. Disconnect the parking brake cable (1).
2. Disconnect the PTO shift wire (3) at the PTO clutch valve (5).
3. Disconnect the traveling speed sensor connector (2).

#### **(When reassembling)**

- Be sure to check and adjust the parking brake lever free play (see page G-27).
- When connecting the PTO shift wire (3) to the clutch valve lever, be sure to adjust the length of wire as follows.
  1. Set the PTO shift lever to **OFF (Neutral)** position.
  2. Loosen the lock nut (4) of wire, and connect wire to the clutch valve lever, and then place the wire to the hook.
  3. Tighten the lock nut (4) clockwise (pull the wire), and lock the nut just before the lever moves.

- |                                      |                      |
|--------------------------------------|----------------------|
| (1) Parking Brake Cable              | (4) Lock Nut         |
| (2) Traveling Speed Sensor Connector | (5) PTO Clutch Valve |
| (3) PTO Shift Wire                   |                      |

W1064487

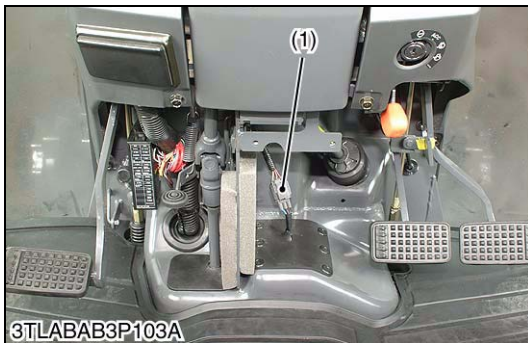

### Shuttle Switch Connector (Manual and GST Model)

1. Remove the panel cover and steering post cover.
2. Disconnect the shuttle switch connector (1).

- (1) Shuttle Switch Connector

W1064666



### Cruise Control Release Wire (HST Model)

1. Disconnect the cruise control release wire (1).

#### **(When reassembling)**

- Be sure to adjust the cruise control release wire (1). (See page 3-S92.)

- (1) Cruise Control Release Wire

W1065090



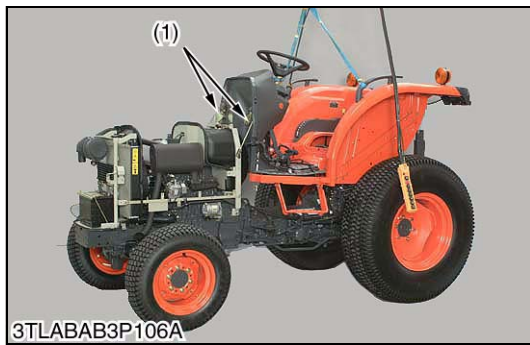

**Step and Floor Seat (ROPS Model)**

1. Disconnect the panel frame connector (1) from fuel tank frame.
2. Remove the step and floor seat mounting bolt and nut.
3. Dismount the step, fender, floor seat and panel frame as a unit after checking whether there is forgetting to disconnect wiring.

**(When reassembling)**

- Be sure to set the washers and rubber plates of the floor seat and step mounting bolt at an original positions as shown in figure.
- Before mounting the floor seat and step, be sure to set both the shuttle lever rod and the shuttle arm to the neutral position, and then connect the shuttle lever rod securely. (Manual and GST model)

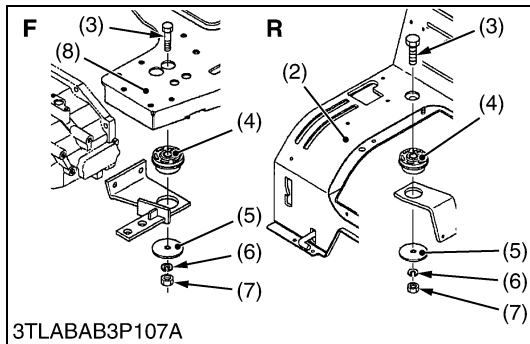

Tightening torque	Step mounting bolt and nut	124 to 147 N·m 12.6 to 15.0 kgf·m 91.1 to 108 ft·lbs
	Floor seat mounting bolt and nut	196 to 225 N·m 20 to 23 kgf·m 145 to 166 ft·lbs

- (1) Panel Frame Connector
  - (2) Floor Seat
  - (3) Bolt
  - (4) Rubber Plate
  - (5) Washer
  - (6) Spring Washer
  - (7) Nut
  - (8) Step
- F : Front Side**  
**R : Rear Side**

W1065411

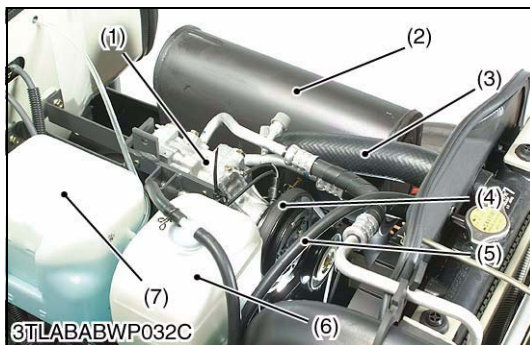

**Air Conditioner Parts (Cabin A/C Model)**

1. Remove the muffler (2).
2. Remove the air conditioner belt (4) and remove the compressor (1) mounting screw.
3. Remove the recovery tank (6) and window washer tank (7).
4. Disconnect the air cleaner hose (8).
5. Disconnect the recovery tank hose (5).
6. Disconnect the radiator upper hose (3).
7. Remove the oil cooler mounting screw. (HST model only)
8. Remove the battery (10).
9. Remove the battery stay mounting bolt.
10. Take out the compressor (1), condenser (11), receiver (12), hoses (13), battery stay (9) and etc. as a unit.

**(When reassembling)**

- After reassembling the compressor, be sure to adjust the air conditioner belt tension. (See page G-29.)

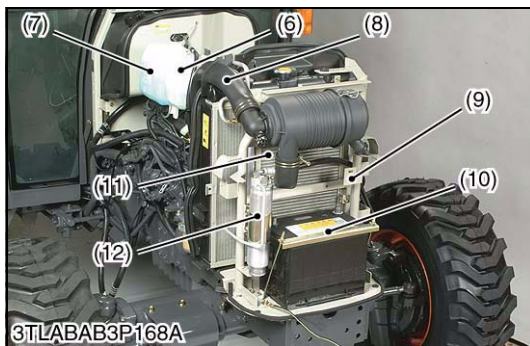

Tightening torque	Compressor mounting screw	24.5 to 29.4 N·m 2.5 to 3.0 kgf·m 18.1 to 21.7 ft·lbs
	Muffler mounting screw	31.4 to 37.2 N·m 3.2 to 3.8 kgf·m 23.1 to 27.5 ft·lbs

- (1) Compressor
- (2) Muffler
- (3) Radiator Upper Hose
- (4) Air Conditioner Belt
- (5) Recovery Tank Hose
- (6) Recovery Tank
- (7) Window Washer Tank
- (8) Air Cleaner Hose
- (9) Battery Stay
- (10) Battery
- (11) Condenser
- (12) Receiver
- (13) Air Conditioner Hose

W1015306

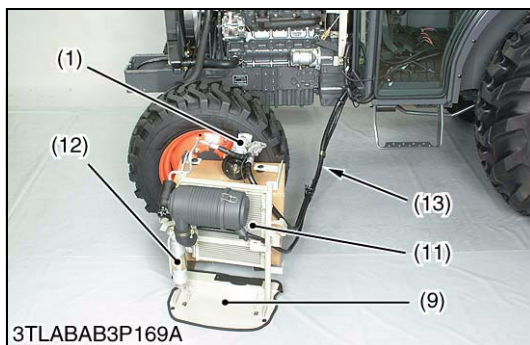





**Cabin Assembly**

1. Remove the outer roof of cabin.
2. Support the cabin with nylon straps (1) and hoists.
3. Loosen and remove the cabin mounting bolts (2) and nuts (9).
4. Dismounting the cabin from tractor body.

■ **NOTE**

- Lift the cabin while making sure it does not catch on anything.

**(When reassembling)**

- Be sure to install the washers and mount rubbers, etc. in their original positions.
- Before mounting the cabin, be sure to set both the shuttle lever rod and the shuttle arm to the neutral position, and then connect the shuttle lever rod securely. (manual and GST model)

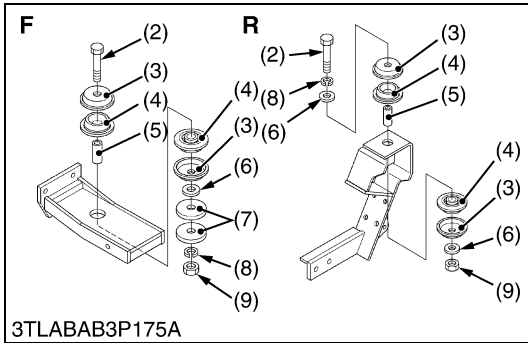

Tightening torque	Cabin mounting bolt and nut	124 to 147 N·m 12.6 to 15.0 kgf·m 91.1 to 108 ft-lbs
-------------------	-----------------------------	--

- |                        |                       |
|------------------------|-----------------------|
| (1) Nylon Straps       | (7) Washer            |
| (2) Bolt               | (8) Spring Washer     |
| (3) Plate              | (9) Nut               |
| (4) Mount Rubber       |                       |
| (5) Collar             | <b>F : Front Side</b> |
| (6) Plain Washer (M14) | <b>R : Rear Side</b>  |

W1067482

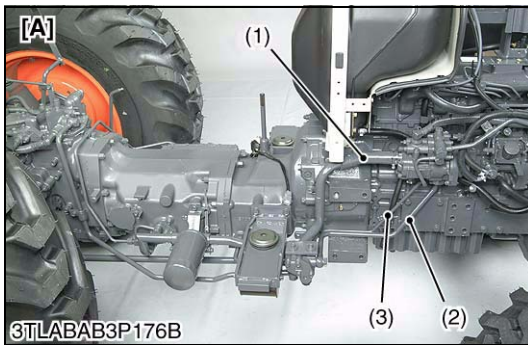

**Hydraulic Pipes**

1. Remove the main delivery pipe 1 (2).
2. Remove the PTO delivery pipe (3). (Manual and GST model)
3. Disconnect the suction hose (1) from hydraulic pump.
4. Remove the joint bolt (4) of oil cooler pipe (5). (HST model)

**(When reassembling)**

Tightening torque	Joint bolt for main delivery pipe 1 to front hydraulic block	49 to 69 N·m 5.0 to 7.0 kgf·m 36.1 to 50.6 ft-lbs
	Joint bolt for PTO delivery pipe	34 to 39 N·m 3.5 to 4.0 kgf·m 25.3 to 28.9 ft-lbs
	Joint bolt for oil cooler pipe	34 to 39 N·m 3.5 to 4.0 kgf·m 25.3 to 28.9 ft-lbs

- |                          |                      |
|--------------------------|----------------------|
| (1) Suction Hose         | (5) Oil Cooler Pipe  |
| (2) Main Delivery Pipe 1 |                      |
| (3) PTO Delivery Pipe    | <b>[A] GST Model</b> |
| (4) Joint Bolt           | <b>[B] HST Model</b> |

W1067766

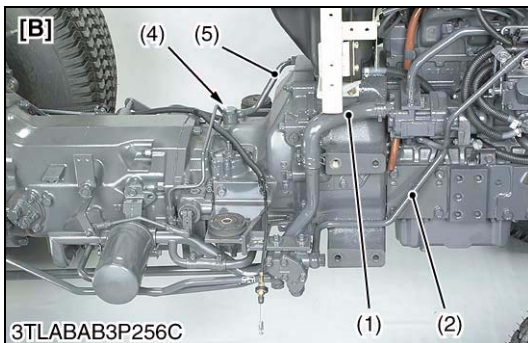

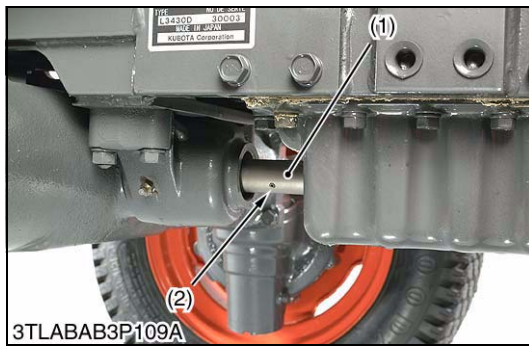
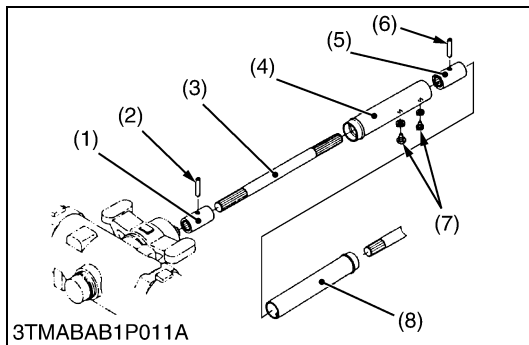

### Propeller Shaft

1. Slide the propeller shaft cover (4) and (8) after removing the screws (7).
2. Tap out the spring pins (2), (6) and slide the couplings (1), (5) and then remove the propeller shaft with covers (4), (8).

#### (When reassembling)

- Apply grease to the splines of propeller shaft 1 (3).

(1) Coupling	(5) Coupling
(2) Spring Pin	(6) Spring Pin
(3) Propeller Shaft 1	(7) Screws
(4) Propeller Shaft Cover	(8) Propeller Shaft Cover

W1068780

### Separating Engine and Clutch Housing

1. Place the disassembling stand under the engine and clutch housing case.
2. Remove the fuel tank support mounting screws.
3. Remove the engine and clutch housing mounting screws and nuts.
4. Separate the engine and clutch housing while lifting up the tank frame.

#### (When reassembling)

- Apply grease to the spline of clutch shaft.
- Apply liquid gasket (Three Bond 1211 or equivalent) to joint face of the flywheel housing and clutch housing.

Tightening torque	Engine and clutch housing mounting screw and nut	77.5 to 90.2 N·m 7.9 to 9.2 kgf·m 57.1 to 66.5 ft·lbs
	Engine and clutch housing mounting stud bolt	39.2 to 49.0 N·m 4.0 to 5.0 kgf·m 28.9 to 36.2 ft·lbs

W1069132

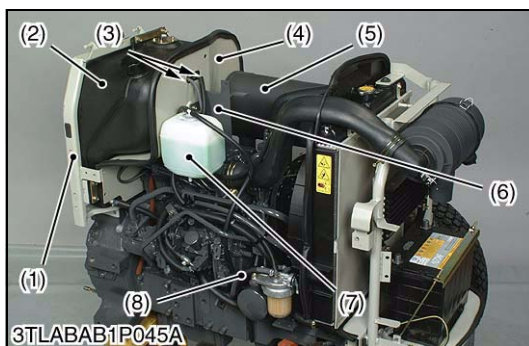

### Fuel Tank

1. Remove the muffler (5). (ROPS model)
2. Disconnect the overflow hoses (3) and fuel hose (8).
3. Remove the reserve tank bracket (6). (ROPS model)
4. Remove the compressor bracket. (Cabin model)
5. Remove the shutter plate (4).
6. Remove the tank frame mounting bolt and remove the fuel tank (2) with frame (1).

#### (When reassembling)

Tightening torque	Muffler mounting screw	31.4 to 37.2 N·m 3.2 to 3.8 kgf·m 23.1 to 27.5 ft·lbs
-------------------	------------------------	---

(1) Fuel Tank Frame	(5) Muffler
(2) Fuel Tank	(6) Reserve Tank Bracket
(3) Overflow Hoses	(7) Recovery Tank
(4) Shutter Plate	(8) Fuel Hose

W1015605

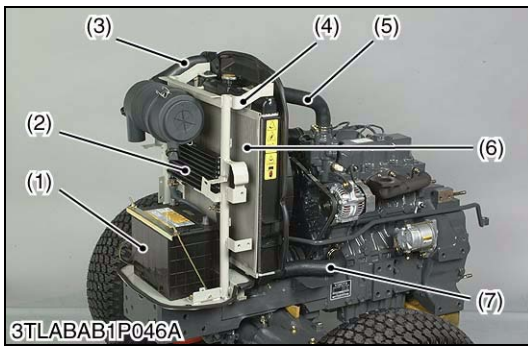

**Radiator Assembly**

1. Disconnect the air cleaner hose (3). (ROPS model)
2. Remove the battery (1). (ROPS model)
3. Remove the oil cooler mounting screws. (ROPS model)
4. Remove the battery stay (4). (ROPS model)
5. Disconnect the radiator hoses (5), (7).
6. Remove the radiator assembly.

- |                                 |                         |
|---------------------------------|-------------------------|
| (1) Battery                     | (5) Radiator Upper Hose |
| (2) Oil Cooler (HST Model Only) | (6) Radiator            |
| (3) Air Cleaner Hose            | (7) Radiator Lower Hose |
| (4) Battery Stay                |                         |

W1015759

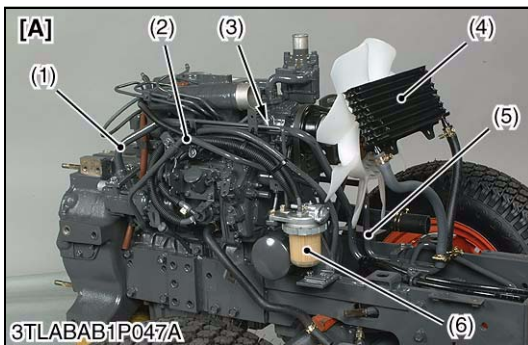

**Hydraulic Pipes and Fuel Filter**

1. Disconnect the hoses and remove the oil cooler (4). (HST model)
2. Remove the oil cooler outlet pipe (1) and inlet pipe (5). (HST model)
3. Remove the power steering delivery pipe (2).
4. Disconnect the power steering return hose (7). (Except HST model.)
5. Remove the fuel filter (6) with bracket (3).

**(When reassembling)**

Tightening torque	Joint bolt for power steering delivery pipe	39.2 to 49.0 N-m 4.0 to 5.0 kgf-m 28.9 to 36.2 ft-lbs
	Cap nut of power steering delivery pipe	49.0 to 58.8 N-m 5.0 to 6.0 kgf-m 36.1 to 43.4 ft-lbs

- |                                  |  |
|----------------------------------|--|
| (1) Oil Cooler Outlet Pipe       | (7) Power Steering Return Hose             |
| (2) Power Steering Delivery Pipe | (8) Hydraulic Pump with Regulating Valve   |
| (3) Bracket                      | (9) Steering Controller                    |
| (4) Oil Cooler                   | <b>[A] HST Model</b>                       |
| (5) Oil Cooler Outlet Pipe       | <b>[B] GST / Manual Transmission Model</b> |
| (6) Fuel Filter                  |  |

W1015859

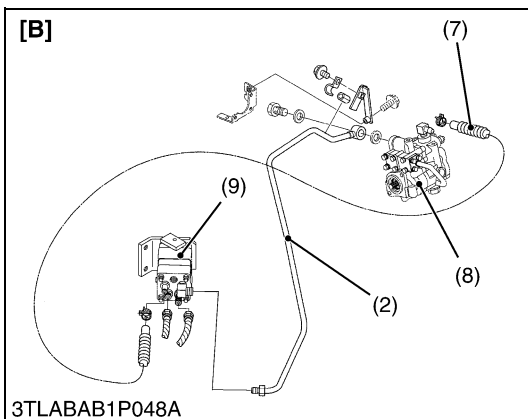

**Front Axle Frame**

1. Hoist the engine by the chain at the engine hook (1).
2. Remove the dipstick stay mounting screw (3) and front axle frame mounting screws.
3. Separate the front axle frame (1) from engine.

**(When reassembling)**

Tightening torque	Front axle frame mounting screw (7T) (L3130, L3430, L3830)	77.5 to 90.2 N-m 7.9 to 9.2 kgf-m 57.1 to 66.5 ft-lbs
	Front axle frame mounting screw (9T) (L4630, L5030)	102.9 to 117.6 N-m 10.5 to 12.0 kgf-m 76.0 to 86.8 ft-lbs

- |                      |                                  |
|----------------------|----------------------------------|
| (1) Engine Hook      | (3) Dipstick Stay Mounting Screw |
| (2) Front Axle Frame |                                  |

W1016162

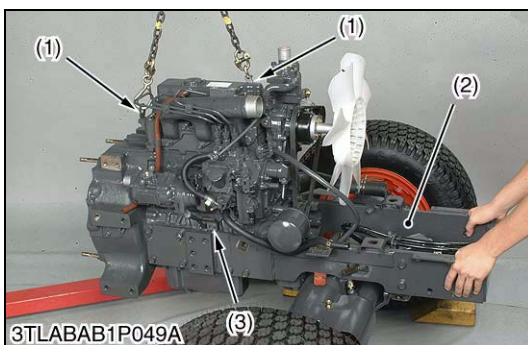



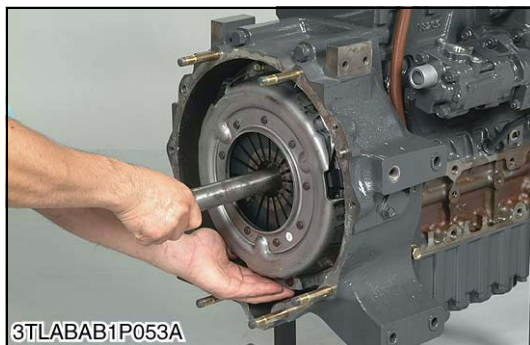
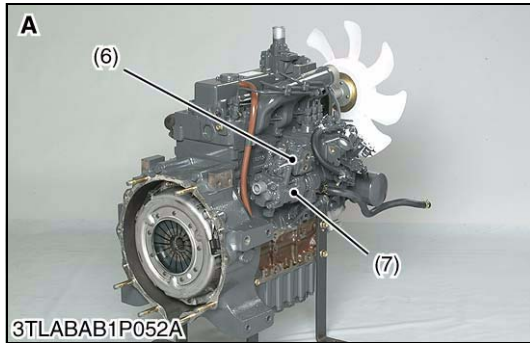
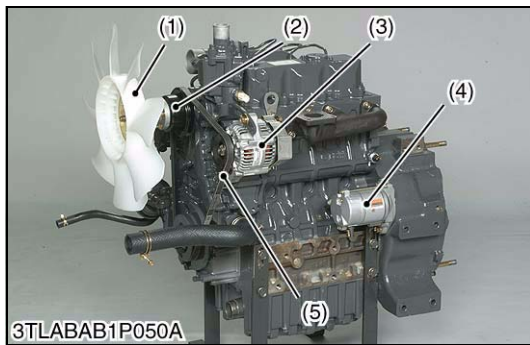

**Outer Parts of Engine**

1. Remove the hydraulic pump (7) with pump holder and regulating valve (6).
2. Remove the radiator fan (1), belt and fan pulley (2).
3. Remove the alternator (3).
4. Remove the starter motor (4).

**(When reassembling)**

- Be sure to adjust the fan belt tension. (Refer to G-23.)

Tightening torque	Alternator mounting screw (M10)	39.2 to 44.1 N·m 4.0 to 4.5 kgf·m 28.9 to 32.5 ft-lbs
	Tension adjusting screw (M8)	17.6 to 20.6 N·m 1.8 to 2.1 kgf·m 13.0 to 15.2 ft-lbs

- (1) Radiator Fan
- (2) Fan Pulley
- (3) Alternator
- (4) Starter Motor
- (5) Fan Belt

- (6) Regulating Valve
- (7) Hydraulic Pump

**A : Manual Transmission and GST Model**  
**B : HST Model**

W10169070

**Clutch Assembly**

1. Remove the clutch from the flywheel.

**(When reassembling)**

- Direct the shorter end of the clutch disc boss toward the flywheel.
- Apply molybdenum disulphide (Three Bond 1901 or equivalent) to the splines of clutch disc boss.
- Install the pressure plate, noting the position of straight pins.

**IMPORTANT**

- **Align the center of disc and flywheel by inserting the clutch center tool. (See page G-47.)**

**NOTE**

- **Do not allow grease and oil on the clutch disc facing.**

Tightening torque	Clutch mounting screws	23.5 to 27.5 N·m 2.4 to 2.8 kgf·m 17.5 to 20.3 ft-lbs
-------------------	------------------------	---

W10171850

## [2] ENGINE BODY

### (1) Checking and Adjusting

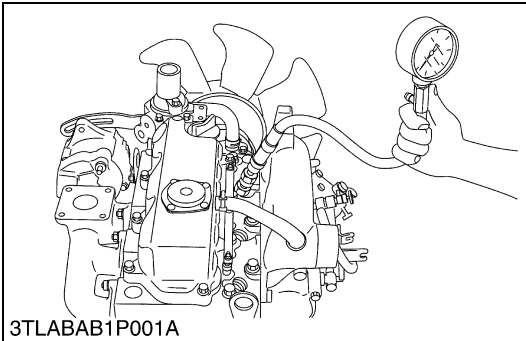

#### Compression Pressure

1. Run the engine until it is warmed up.
2. Stop the engine and disconnect the **2P** connector from the stop solenoid in order to inject fuel.
3. Remove the air cleaner, the muffler and all injection nozzles.
4. Set a compression tester (Code No. 07909-30208) with the adaptor to the nozzle hole.
5. Keep the engine stop lever at “**Stop Position**”.
6. While cranking the engine with the starter, measure the compression pressure.
7. Repeat steps 4 through 6 for each cylinder.
8. If the measurement is below the allowable limit, apply a small amount of oil to the cylinder wall through the nozzle hole and measure the compression pressure again.
9. If the compression pressure is still less than the allowable limit, check the top clearance, valve and cylinder head.
10. If the compression pressure increases after applying oil, check the cylinder wall and piston rings.

#### ■ NOTE

- Check the compression pressure with the specified valve clearance.
- Always use a fully charged battery for performing this test.
- Variances in cylinder compression values should be under **10 %**.

Compression pressure	Factory spec.	3.53 to 4.02 MPa 36 to 41 kgf/cm <sup>2</sup> 512 to 583 psi
	Allowable limit	2.55 MPa 26 kgf/cm <sup>2</sup> 370 psi

W1018639

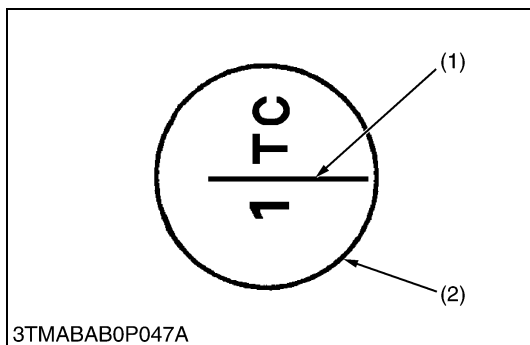
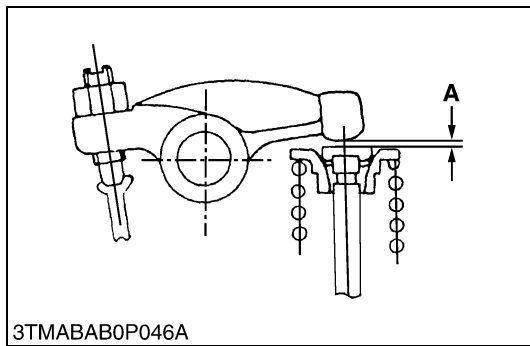
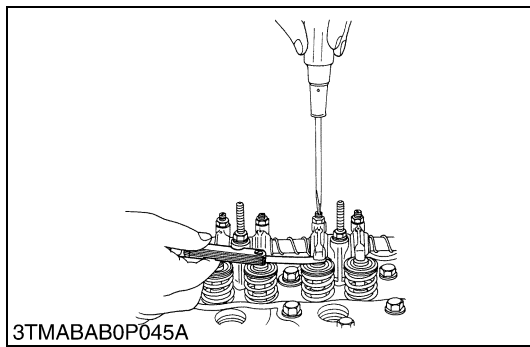

### Valve Clearance

#### ■ IMPORTANT

- Valve clearance must be checked and adjusted when engine is cold.
1. Remove the head cover, the glow plugs and the timing window cover on the clutch housing.
  2. Align the “1TC” mark line on the flywheel and center of timing window so that the No. 1 piston comes to the compression or overlap top dead center.
  3. Check the following valve clearance marked with “☆” using a feeler gauge.
  4. If the clearance is not within the factory specifications, adjust with the adjusting screw.

Valve clearance	Factory spec.	0.18 to 0.22 mm 0.0071 to 0.0087 in.
-----------------	---------------	---

#### ■ NOTE

- The “TC” marking line on the flywheel is just for No. 1 cylinder. There is no “TC” marking for the other cylinders.
- No. 1 piston comes to the T.D.C. position when the “TC” marking is aligned with center of timing window on clutch-housing. Turn the flywheel 0.26 rad (15 °) clockwise and counterclockwise to see if the piston is at the compression top dead center or the overlap position. Now referring to the table below, readjust the valve clearance. (The piston is at the compression top dead center when both the IN. and EX. valves do not move; it is at the overlap position when both the valves move.)
- Finally turn the flywheel 6.28 rad (360 °) and align the “TC” marking line and the center of timing window. Adjust all the other valve clearance as required.
- After turning the flywheel counterclockwise twice or three times, recheck the valve clearance, firmly tighten the lock nut of the adjusting screw.

Valve arrangement		D1503-M D1703-M D1803-M		V2203-M V2403-M	
		IN.	EX.	IN.	EX.
Adjustable cylinder location of piston	No. 1	☆	☆	☆	☆
	No. 2		☆	☆	
	No. 3	☆			☆
	No. 4	—	—		
When No. 1 piston is compression top dead center	No. 1				
	No. 2	☆			☆
	No. 3		☆	☆	
	No. 4	—	—	☆	☆

- (1) TC Mark Line
- (2) Timing Window

A : Valve Clearance

W1018974

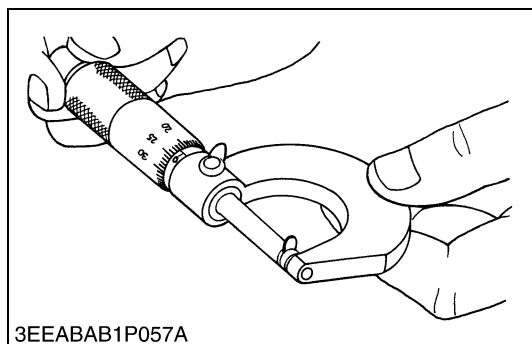
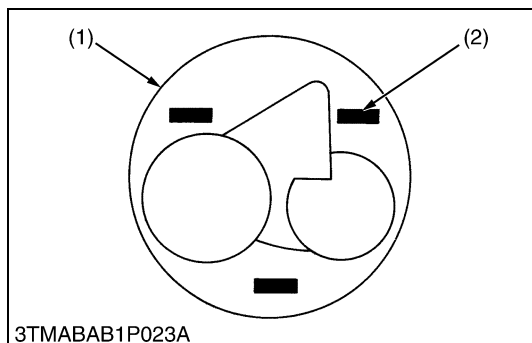

**Top Clearance**

1. Remove the cylinder head.
2. Move the piston up and stick a strip of fuse on the piston head at three position with grease.
3. Lower the piston and install the cylinder head. (Use a new cylinder head gasket and tighten with a specified tightening torque.)
4. Turn the flywheel until the piston passes through the T.D.C..
5. Remove the cylinder head and measure the thickness of the fuses.
6. If the measurement is not within the factory specifications, check the oil clearances between the crankpin and bearing and between the piston pin and bushing.

Top clearance	Factory spec.	0.55 to 0.70 mm 0.0217 to 0.0276 in.
---------------	---------------	---

Tightening torque	Cylinder head screws	93.1 to 98.0 N-m 9.5 to 10.0 kgf-m 68.7 to 72.3 ft-lbs
-------------------	----------------------	--

(1) Piston

(2) Fuse

W1020190

**(2) Disassembling and Assembling**

**(A) Cylinder Head and Valves**

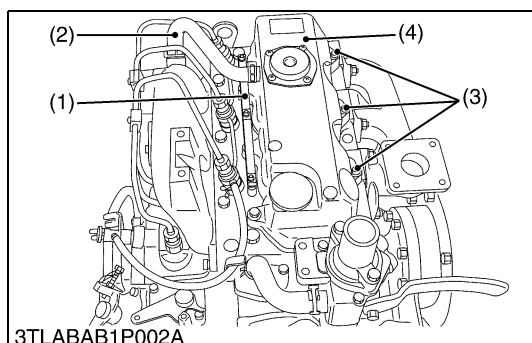

**Cylinder Head Cover**

1. Remove the lead (1).
2. Remove the breather hose (2).
3. Remove the head cover screws (3).
4. Remove the cylinder head cover (4).

**(When reassembling)**

- Check to see if the cylinder head cover gasket is not defective.

Tightening torque	Cylinder head cover screw	6.9 to 11.3 N-m 0.7 to 1.15 kgf-m 5.1 to 8.32 ft-lbs
-------------------	---------------------------	--

(1) Lead

(2) Breather Hose

(3) Head Cover Screw

(4) Cylinder Head Cover

(5) Cylinder Head Cover Gasket

(6) Breather Valve

(7) Plate

W1060460

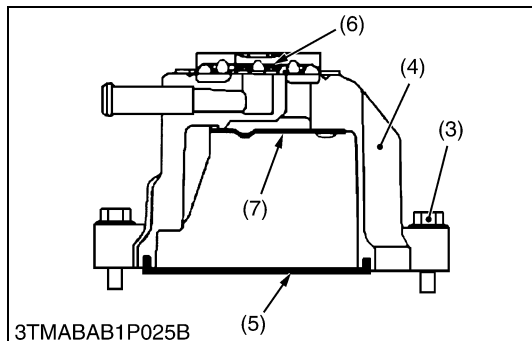
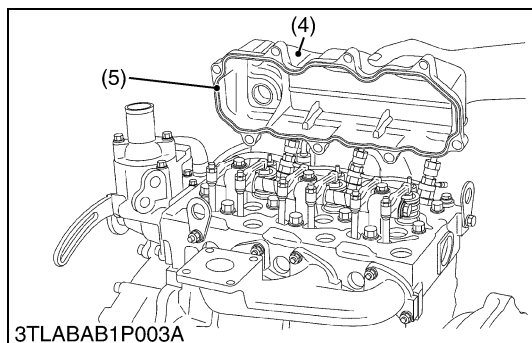

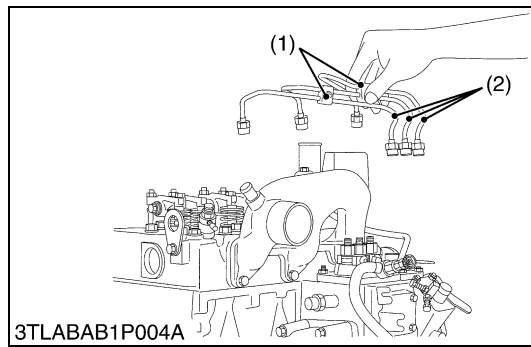

### Injection Pipes

- Loosen the screws on the pipe clamps (1).
- Detach the injection pipes (2).

#### (When reassembling)

- Blow out dust inside the pipes.

Tightening torque	Injection pipe retaining nut	24.5 to 34.3 N·m 2.5 to 3.5 kgf·m 18.1 to 25.3 ft·lbs
-------------------	------------------------------	---

(1) Pipe Clamp

(2) Injection Pipe

W1060970

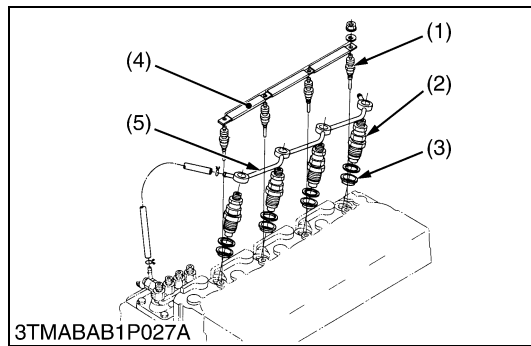

### Nozzle Holder Assembly and Glow Plug

- Remove the overflow pipe assembly (5).
- Remove the nozzle holder assemblies (2) using a 21 mm deep socket wrench.
- Remove the copper gasket and heat seal (3).
- Remove the glow plugs (1).

#### (When reassembling)

- Replace the copper gasket and heat seal with new one.

Tightening torque	Nozzle holder assembly	49.0 to 68.6 N·m 5.0 to 7.0 kgf·m 36.2 to 50.6 ft·lbs
	Overflow pipe assembly retaining nut	19.6 to 24.5 N·m 2.0 to 2.5 kgf·m 14.5 to 18.1 ft·lbs
	Glow plug	19.6 to 24.5 N·m 2.0 to 2.5 kgf·m 14.5 to 18.1 ft·lbs

(1) Glow Plug

(4) Lead

(2) Nozzle Holder Assembly

(5) Overflow Pipe Assembly

(3) Heat Seal

W1020917

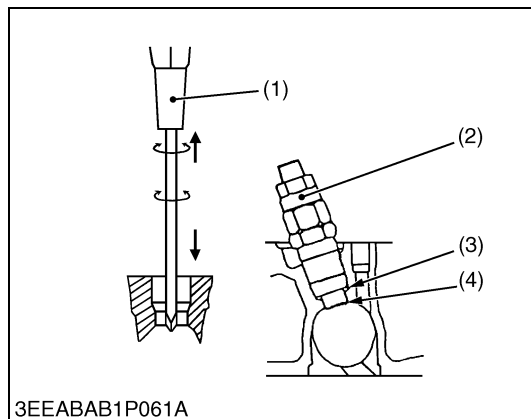

### Nozzle Heat Seal Service Removal Procedure

#### ■ IMPORTANT

- Use a plus (phillips head) screw driver (1) that has a Dia. which is bigger than the heat seal hole (Approx. 6 mm) 1/4 in.
- Drove screw drive (1) lightly into the heat seal hole.
  - Turn screw driver three or four times each way.
  - While turning the screw driver, slowly pull the heat seal (4) out together with the copper gasket (3).
  - If the heat seal drops, repeat the above procedure.

#### (When reassembling)

- Heat seal and copper gasket must be changed when the injection nozzle is removed for cleaning or for service.

(1) Plus Screw Driver

(3) Copper Gasket

(2) Nozzle Holder

(4) Heat Seal

W1021255



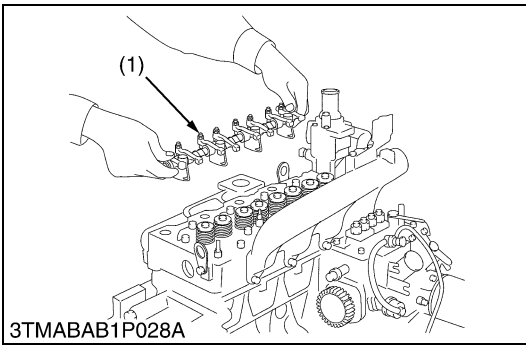

### Rocker Arm and Push Rod

1. Remove the rocker arm bracket nuts.
2. Detach the rocker arm assembly (1).
3. Remove the push rods (2).

#### (When reassembling)

- When putting the push rods (2) onto the tappets (3), check to see if their ends are properly engaged with the grooves.

#### ■ IMPORTANT

- After installing the rocker arm, be sure to adjust the valve clearance.

Tightening torque	Rocker arm bracket nut	23.5 to 27.5 N·m 2.4 to 2.8 kgf·m 17.4 to 20.3 ft-lbs
-------------------	------------------------	---

(1) Rocker Arm Assembly

(3) Tappet

(2) Push Rod

W1021437

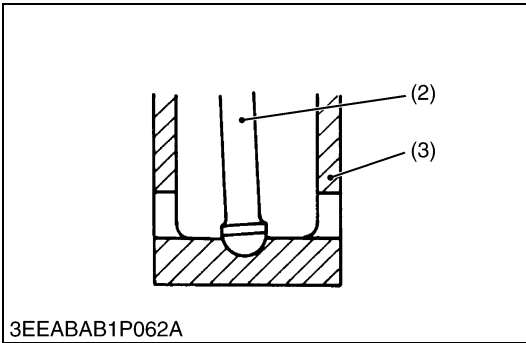

### Cylinder Head

1. Loosen the pipe clamp (1), and remove the water return pipe (2).
2. Remove the cylinder head screw in the order of (r or n) to (a).
3. Lift up the cylinder head (3) to detach.
4. Remove the cylinder head gasket (4).

#### (When reassembling)

- Replace the cylinder head gasket with a new one.
- Tighten the cylinder head screws after applying sufficient oil.
- Tighten the cylinder head screws in diagonal sequence starting from the center in the order of (a) to (n or r).
- Tighten them uniformly, or the head may deform in the long run.

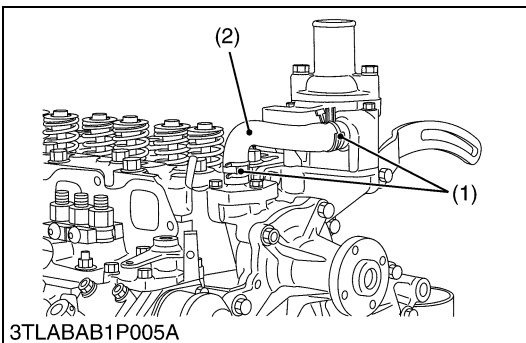

Tightening torque	Cylinder head screw	93.1 to 98.0 N·m 9.5 to 10.0 kgf·m 68.7 to 72.3 ft-lbs
-------------------	---------------------	--

(1) Pipe Clamp

(2) Return Pipe

(3) Cylinder Head

(4) Cylinder Head Gasket

(r or n) to (a): To Loosen

(a) to (n or r): To Tighten

(A) Gear Case Side

(B) Flywheel Side

W1021755

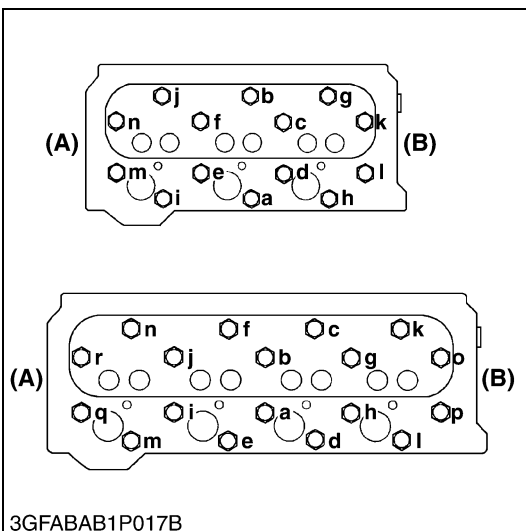

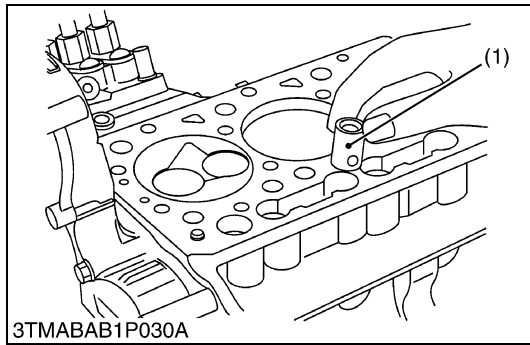

### **Tappets**

1. Remove the tappets (1) from the crankcase.

#### **(When reassembling)**

- Visually check the contact between tappets and cams for proper rotation. If defect is found, replace tappets.
- Before installing the tappets, apply engine oil thinly around them.

#### ■ **IMPORTANT**

- **Do not change the combination of tappet and tappet guide of the crankcase.**

(1) Tappet

W1022001

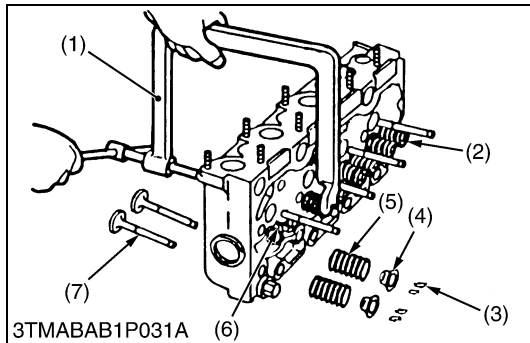

### **Valves**

1. Remove the valve caps (2).
2. Remove the valve spring collet (3), pushing the valve spring retainer (4) by valve spring replacer (1).
3. Remove the valve spring retainer (4), valve spring (5) and valve stem seal (6).
4. Remove the valve (7).

#### **(When reassembling)**

- Wash the valve stem and valve guide hole, and apply engine oil sufficiently.
- After installing the valve spring collets, lightly tap the stem to assure proper fit with a plastic hammer.

#### ■ **IMPORTANT**

- **Don't change the combination of valve and valve guide hole.**

(1) Valve Spring Replacer

(2) Valve Cap

(3) Valve Spring Collet

(4) Valve Spring Retainer

(5) Valve Spring

(6) Valve Stem Seal

(7) Valve

W1022102

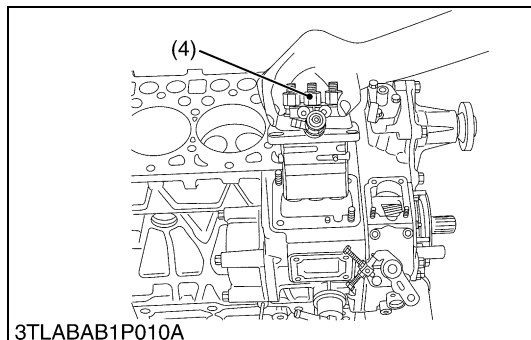
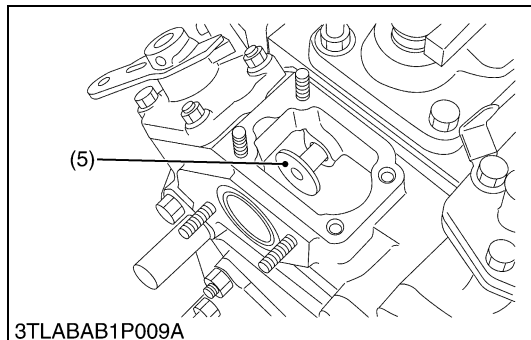
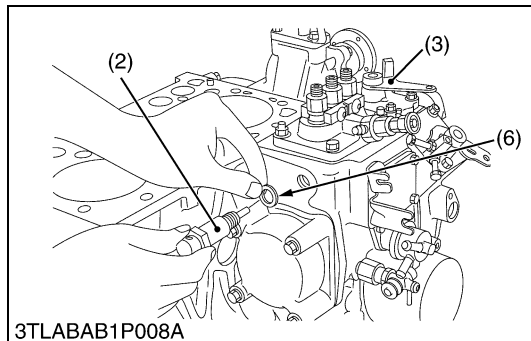
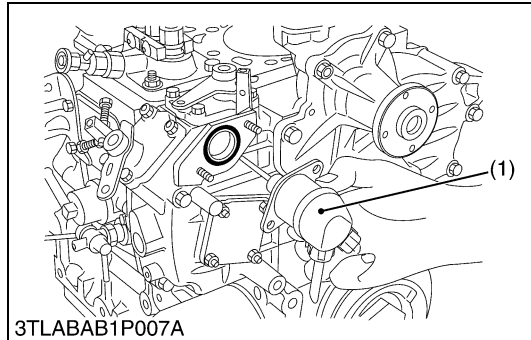
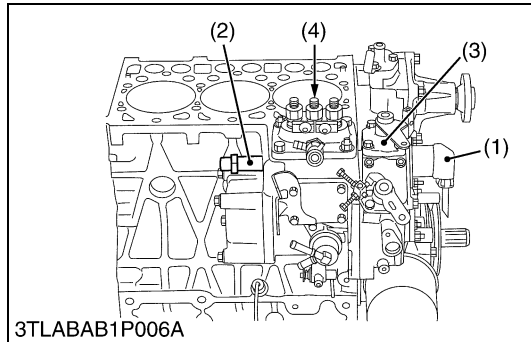
**(B) Timing Gears, Camshaft and Fuel Camshaft****Injection Pump**

1. Remove the stop solenoid (1) and hi-idling body (2).
2. Remove the engine stop lever (3) and stop solenoid guide (5).
3. Remove the fuel injection pump assembly (4).

**■ IMPORTANT**

- Before removing the injection pump assembly (4), be sure to remove the stop solenoid (1), hi-idling body (2), engine stop lever (3) and stop solenoid guide (5).

**(When reassembling)**

- Before attaching the stop solenoid, hi-idling body and solenoid guide, install the injection pump first into position.
- Replace the hi-idling body gasket (6) with a new one.
- Before fitting the stop lever to the gear case, install the solenoid guide first into position. Then attach the stop lever and use it to see if it functions well.
- Before fitting the idling limiter in place, attach the solenoid guide and the engine stop lever in their respective positions.
- When installing the stop solenoid, be careful to keep the O-ring in place.
- Be sure to insert the push rod of the stop solenoid into the hole at the center of the solenoid guide.

Tightening torque	Hi-idling body	44.1 to 49.0 N·m 4.5 to 5.0 kgf·m 32.6 to 36.3 ft·lbs
-------------------	----------------	---

- |                    |                             |
|--------------------|-----------------------------|
| (1) Stop Solenoid  | (4) Injection Pump Assembly |
| (2) Hi-idling Body | (5) Solenoid Guide          |
| (3) Stop Lever     | (6) Hi-idling Body Gasket   |

W1023686

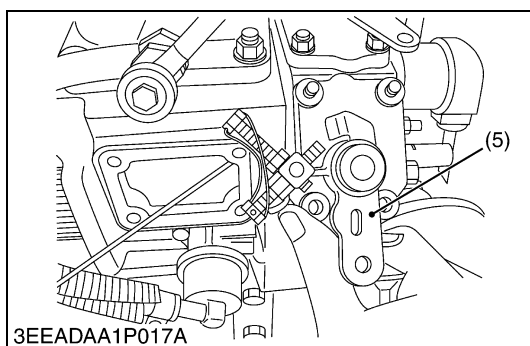
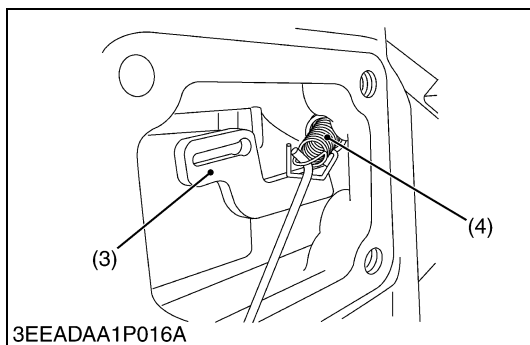
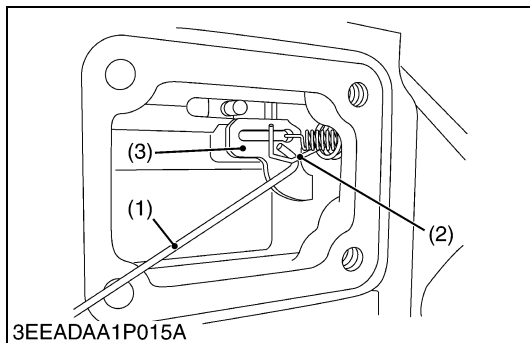
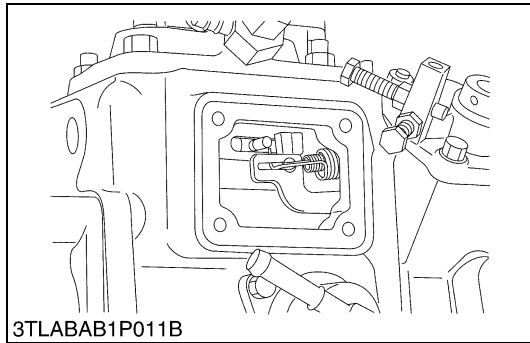
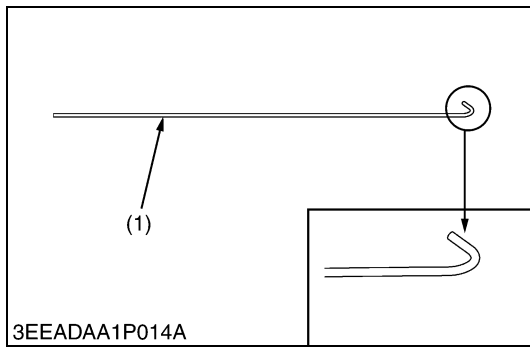

## Governor Springs and Speed Control Plate

### NOTE

- **Specific tool (1) :**  
1.2 mm diameter hard wire with its end hooked, overall length 200 mm (7.87 in.).

The tip of wire is bent like the hook to hang governor springs.

1. Remove the injection pump cover.
2. Remove the speed control plate (6) mounting nuts and bolts.
3. Using the specific tool (1), undo the large governor spring (2) from the fork lever (3).
4. Using the specific tool (1), undo the small governor spring (4) from the fork lever (3).
5. Set the speed control lever (5) as the figure.
6. Take out the speed control plate (6) with care not to let the large (2) and small (4) governor springs come off this plate and fall in to the gear case.

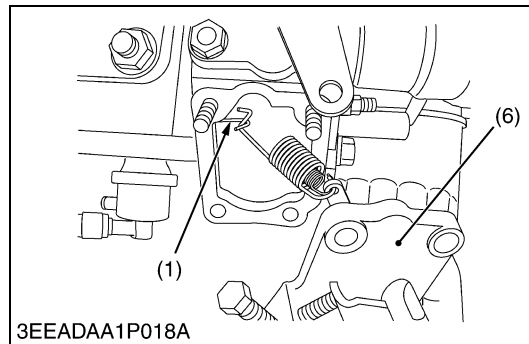

- |                           |                           |
|---------------------------|---------------------------|
| (1) Specific Tool         | (4) Small Governor Spring |
| (2) Large Governor Spring | (5) Speed Control Lever   |
| (3) Fork Lever            | (6) Speed Control Plate   |

W1148604

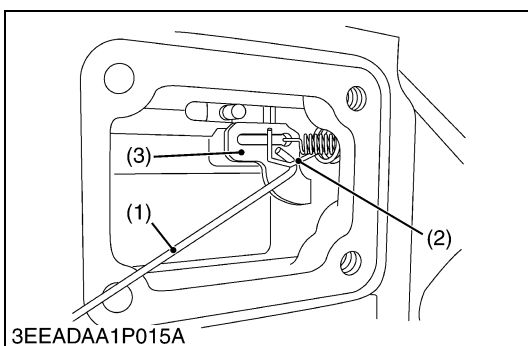
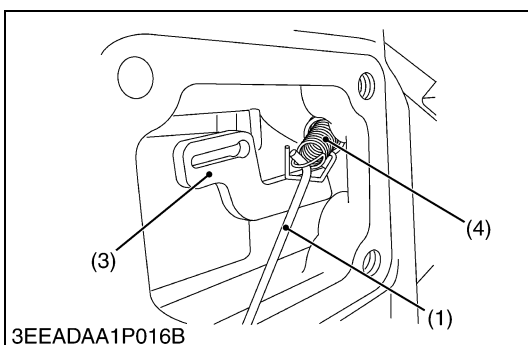
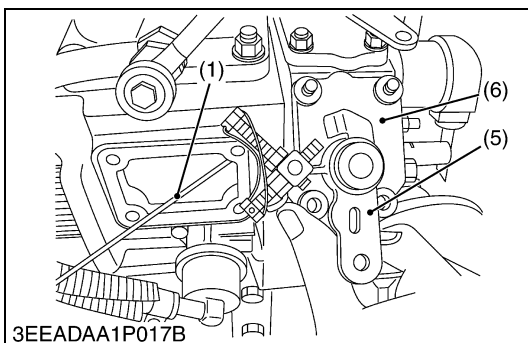
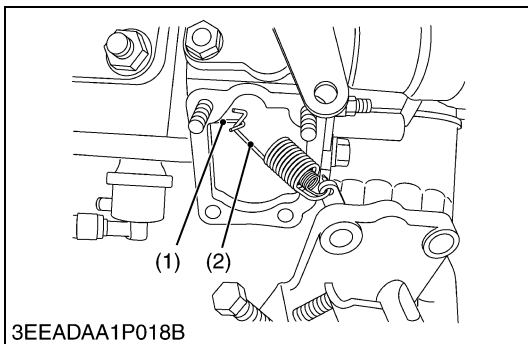
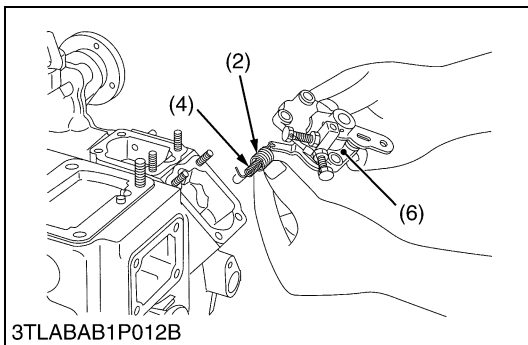

### Governor Springs and Speed Control Plate (Continued)

#### (When reassembling)

- Hook the small spring (4) first and then the large governor spring (2) on the speed control plate (6).
- Put the specific tool (1) from the injection pump side to catch the large governor spring (2). Keep this spring slightly extended and place the speed control plate (6) in its specified position.
- Using the specific tool (1), hook the small governor spring onto the fork lever (3).

#### ■ NOTE

- Be careful not to stretch the small governor spring (4) too long because otherwise it may get deformed permanently.
- Using the specific tool (1), hook the large governor spring (2) onto the fork lever (3).
- Make sure both the governor springs (2), (4) are tight on the fork lever (3).
- Apply and tighten up the two bolts and two nuts on the speed control plate (6).
- Check that the speed control lever (5) positions low idle, after assembling governor springs.
- Check that the speed control lever (5) returns to the high idle position rather than the low idle position, after moving the lever to the maximum speed position.
- Finally attach the injection pump cover in position.

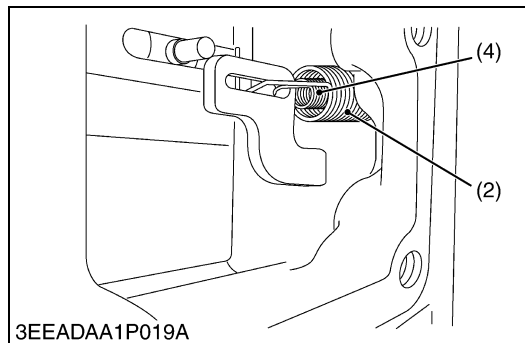

- (1) Specific Tool
- (2) Large Governor Spring
- (3) Fork Lever

- (4) Small Governor Spring
- (5) Speed Control Lever
- (6) Speed Control Plate

W1152334

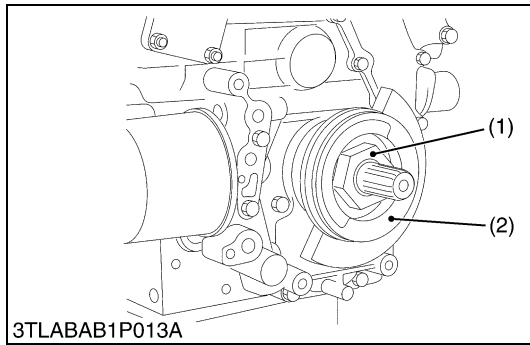

### Fan Drive Pulley

1. Lock the flywheel not to turn using the flywheel stopper.
2. Remove the fan drive pulley mounting nut (1).
3. Remove the fan drive pulley (2) with gear puller (3).
4. Remove the feather key.

#### (When reassembling)

- Apply grease to the splines of coupling.

Tightening torque	Fan drive pulley mounting nut	137.3 to 156.9 N·m 14.0 to 16.0 kgf·m 101.3 to 115.7 ft·lbs

- (1) Nut  
(2) Fan Drive Pulley

(3) Gear Puller

W1024348

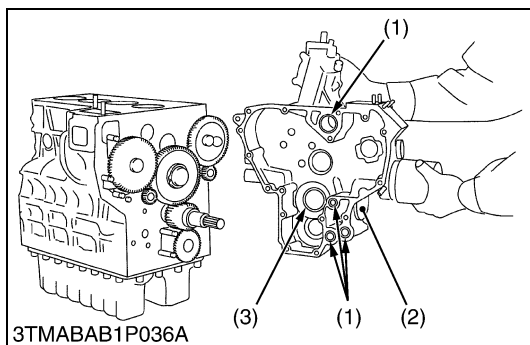
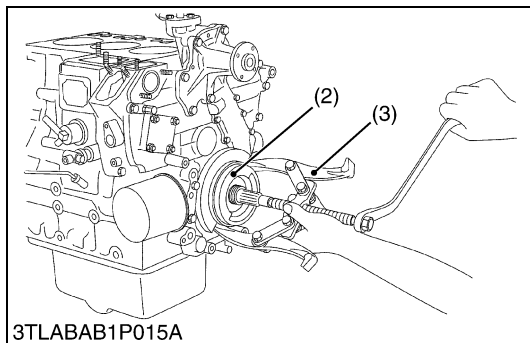
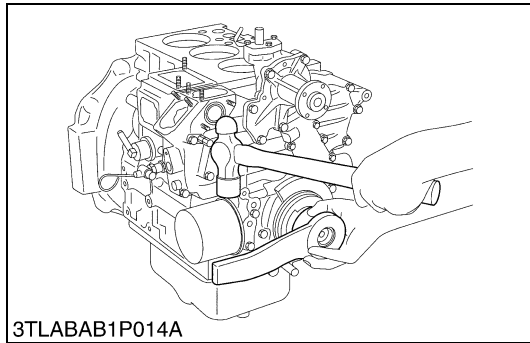

### Gear Case

1. Remove the hour meter gear case.
2. Remove the gear case (2).
3. Remove the O-rings (1).

#### (When reassembling)

- Apply liquid gasket (Three Bond 1215 or equivalent) to both side of hour meter gear case gasket.
- Check to see if there are four O-rings (1) inside the gear case (2).
- Apply a thin film of engine oil to the oil seal (3), and install it, noting the lip come off.
- Before installing the gear case gasket, apply a non-drying adhesive.

- (1) O-ring  
(2) Gear Case

(3) Oil Seal

W1024531

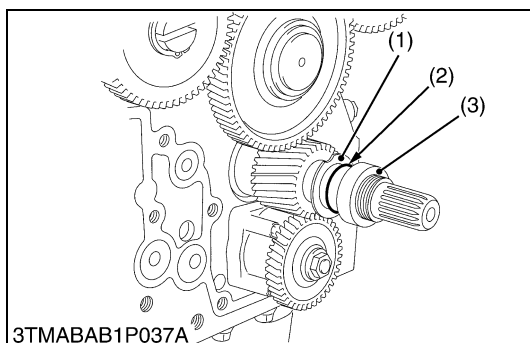

### Crankshaft Oil Slinger

1. Remove the feather key.
2. Remove the crankshaft collar (3).
3. Remove the O-ring (2).
4. Detach the crankshaft oil slinger (1).

- (1) Crankshaft Oil Slinger  
(2) O-ring

(3) Crankshaft Collar

W1024731

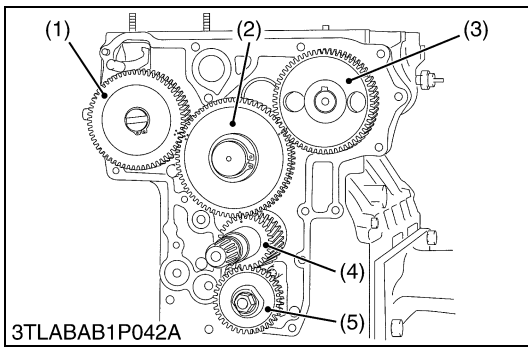

**Idle Gear (for D1503-M, D1703-M and D1803-M)**

1. Remove the external snap ring.
2. Detach the idle gear collar.
3. Detach the idle gear (2).

**(When reassembling)**

- Check to see each gear is aligned with its aligning mark
  - Idle gear (2) and crank gear (4)
  - Idle gear (2) and cam gear (3)
  - Idle gear (2) and injection pump gear (1)

- |                         |                         |
|-------------------------|-------------------------|
| (1) Injection Pump Gear | (4) Crank Gear          |
| (2) Idle Gear           | (5) Oil Pump Drive Gear |
| (3) Cam Gear            |                         |

W1043023

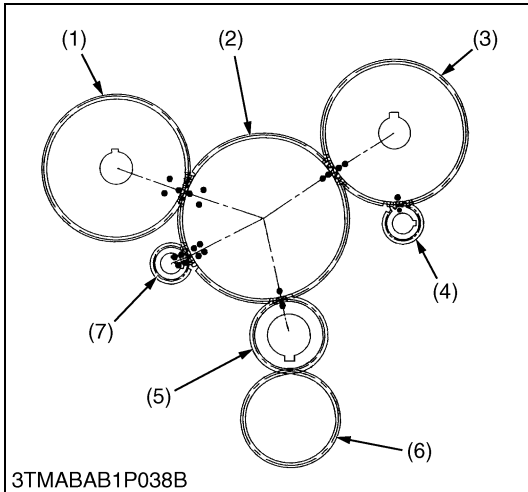
**Idle Gear (for V2203-M and V2403-M)**

1. Remove the external snap ring.
2. Detach the idle gear collar.
3. Detach the idle gear (2).

**(When reassembling)**

- Check to see each gear is aligned with its aligning mark:
  - Idle gear (2) and crank gear (5), cam gear (3) and balancer gear (4)
  - Cam gear (3) and idle gear (2)
  - Idle gear (2) and injection pump gear (1)
  - Idle gear (2) and balancer gear (7)

- |                         |                         |
|-------------------------|-------------------------|
| (1) Injection Pump Gear | (5) Crank Gear          |
| (2) Idle Gear           | (6) Oil Pump Drive Gear |
| (3) Cam Gear            | (7) Balancer Gear       |
| (4) Balancer Gear       |                         |

W1024941

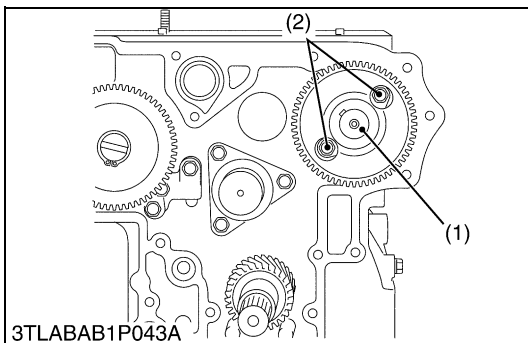
**Camshaft (for D1503-M, D1703-M and D1803-M)**

1. Remove the camshaft set bolts (2) and draw out the camshaft (1).

**(When reassembling)**

- When installing the idle gear, be sure to align the alignment marks on gears.

Tightening torque	Camshaft set bolt	23.5 to 27.5 N·m 2.4 to 2.8 kgf·m 17.4 to 20.3 ft·lbs

- |              |                       |
|--------------|-----------------------|
| (1) Camshaft | (2) Camshaft Set Bolt |
|--------------|-----------------------|

W1046059

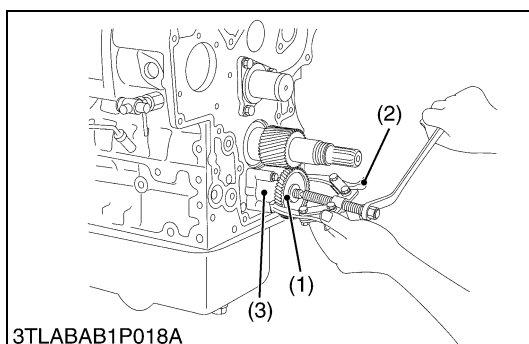
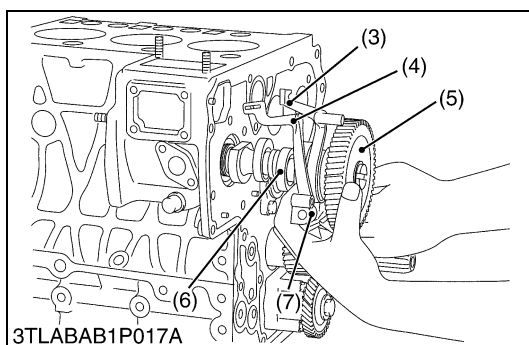
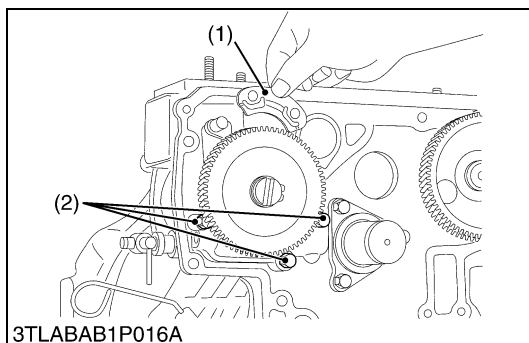
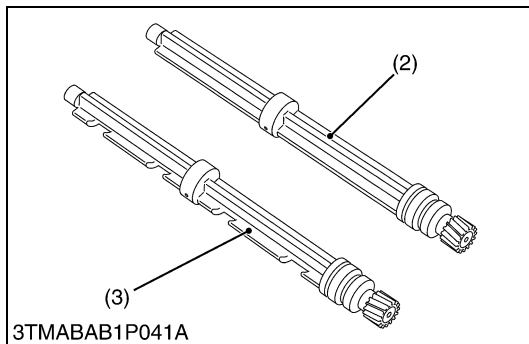
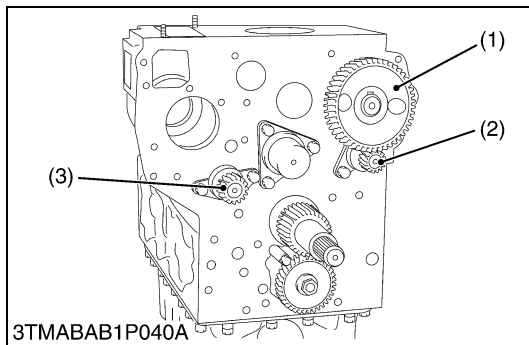

### Camshaft and Balancer Shaft (for V2203-M and V2403-M)

1. Remove the camshaft set bolts and draw out the camshaft (1).
2. Remove the balancer shaft 1 (2) set bolts and draw out the balancer shaft 1 (2).
3. Remove the balancer shaft 2 (3) set bolts and draw out the balancer shaft 2 (3).

#### (When reassembling)

- When install the balancer shaft 1 and 2, be sure to place the 1st and 4th cylinders piston at the top dead center in compression then, align all mating marks on each gear to assemble the timing gears, set the idle gear last.

Tightening torque	Camshaft set bolt	23.5 to 27.5 N·m 2.4 to 2.8 kgf·m 17.4 to 20.3 ft·lbs
	Balancer shaft set bolt	23.5 to 27.5 N·m 2.4 to 2.8 kgf·m 17.4 to 20.3 ft·lbs

(1) Camshaft

(2) Balancer Shaft 1

(3) Balancer Shaft 2

W1025098

### Fuel Camshaft and Fork Lever Assembly

1. Remove the fuel feed pump.
2. Detach the fuel camshaft stopper (1).
3. Remove the three fork lever holder mounting screws (2).
4. Draw out the fuel camshaft assembly (5), (6) and fork lever assembly (3), (4), (7) at the same time.

#### (When reassembling)

- After installation, check to see that the fork lever 1 (3) and 2 (4) are fixed to the fork lever shaft, and that they can turn smoothly in the holder (7).

(1) Fuel Camshaft Stopper

(2) Fork Lever Holder Mounting Screws

(3) Fork Lever 1

(4) Fork Lever 2

(5) Injection Pump Gear

(6) Fuel Camshaft

(7) Fork Lever Holder

W1025309

### Oil Pump

1. Remove the nut.
2. Draw out the oil pump drive gear (1) with gear puller (2).
3. Remove the four oil pump mounting screws. Detach the oil pump (3).

(1) Oil Pump Drive Gear

(2) Gear Puller

(3) Oil Pump

W1025581



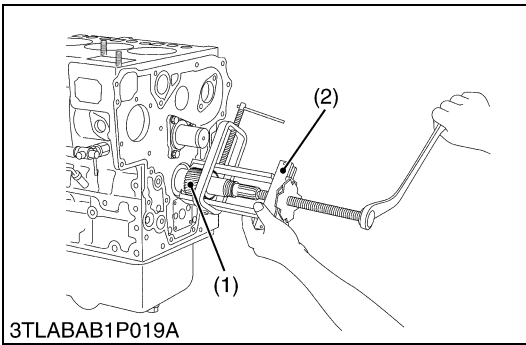

### Crank Gear

1. Draw out the crank gear (1) with a puller (2).
2. Remove the feather key.

(1) Crank Gear

(2) Gear Puller

W1025476

### (C) Piston and Connecting Rod

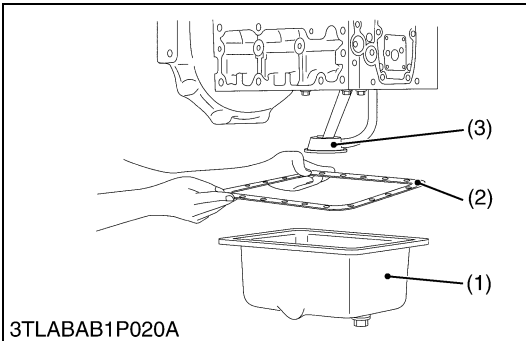

### Oil Pan and Oil Strainer

1. Remove the oil pan mounting screws.
2. Remove the oil pan (1) by lightly tapping the rim of the pan with a wooden hammer.
3. Remove the oil pan gasket (2).
4. Remove the oil strainer (3) and O-ring (4).

#### (When reassembling)

- After cleaning the oil strainer (3), check to see that the filter mesh is clean, and install it.
- Visually check the O-ring (4), apply engine oil, and install it.
- Securely fit the O-ring (4) to the oil strainer (3).
- Apply a liquid gasket (Three Bond 1215 or equivalent) to the oil pan side of the oil pan gasket (2).
- To avoid uneven tightening, tighten oil pan mounting screws in diagonal order from the center.

(1) Oil Pan

(3) Oil Strainer

(2) Oil Pan Gasket

(4) O-ring

W1025687

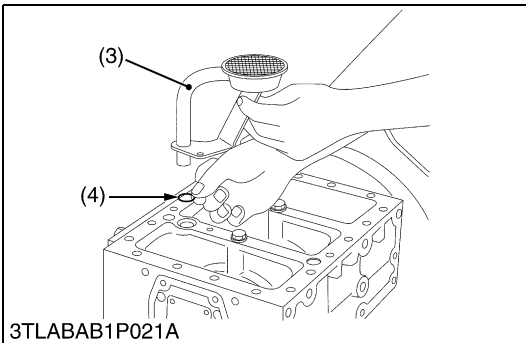

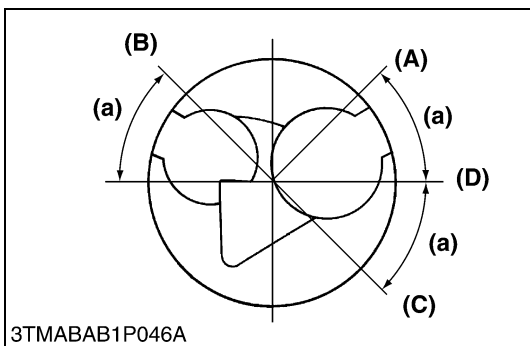
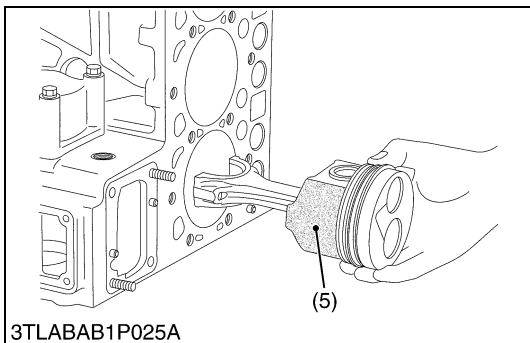
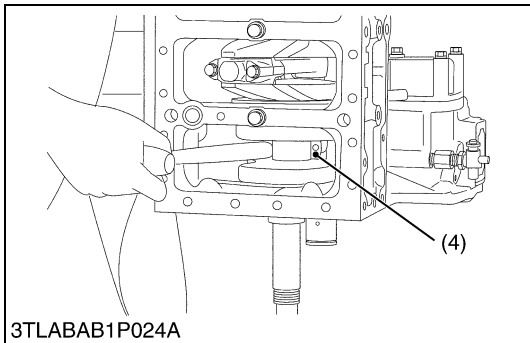
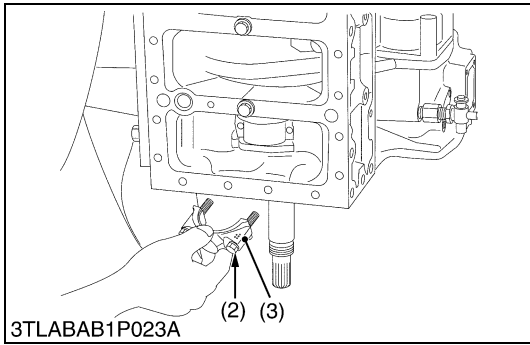
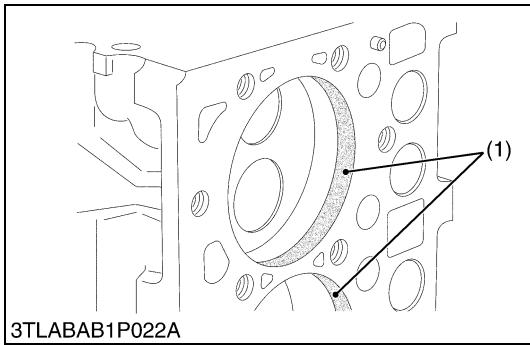

**Pistons**

1. Completely clean carbon (1) in the cylinders.
2. Remove the connecting rod cap (3).
3. Turn the flywheel and bring the piston to top dead center.
4. Draw out the piston upward by lightly tapping it from the bottom of the crankcase with the grip of a hammer.
5. Draw out the other piston in the same method as above.

**(When reassembling)**

- Before inserting piston into the cylinder, apply enough engine oil to the piston.
- When inserting the piston into the cylinder, face the mark on the connecting rod to the injection pump.

**■ IMPORTANT**

- **Do not change the combination of cylinder and piston. Make sure of the position of each piston by marking. For example, mark "1" on the No. 1 piston.**
- **Place the piston rings with their gaps at 0.79 rad (45 °) from the piston pin's direction as shown in the figure.**
- **Carefully insert the pistons using a piston ring compressor.**
- **When inserting the piston in place, be careful not to get the molybdenum disulfide coating torn off its skirt. This coating is useful in minimizing the clearance with the cylinder liner. Just after the piston pin has been press-fitted, in particular, the piston is still hot and the coating is easy to peel off. Wait until the piston cools down.**

Tightening torque	Connecting rod screw	44.1 to 49.0 N·m 4.5 to 5.0 kgf·m 32.5 to 36.2 ft·lbs
-------------------	----------------------	---

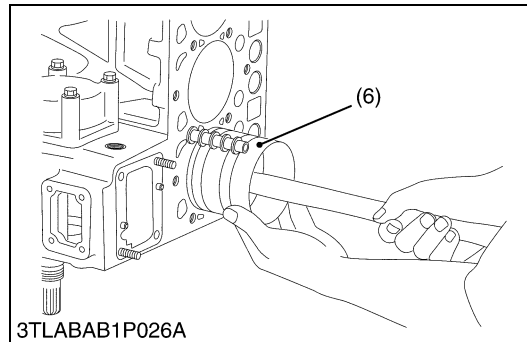

- (1) Carbon
- (2) Connecting Rod Screw
- (3) Connecting Rod Cap
- (4) Connecting Rod
- (5) Molybdenum Disulfide Coating in Piston Skirt
- (6) Piston Ring Compressor
- (A) Top Ring Gap
- (B) Second Ring Gap
- (C) Oil Ring Gap
- (D) Piston Pin Hole
- (a) 0.79 rad (45 °)

W1026141

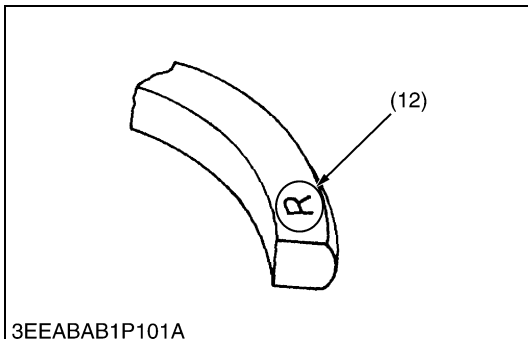
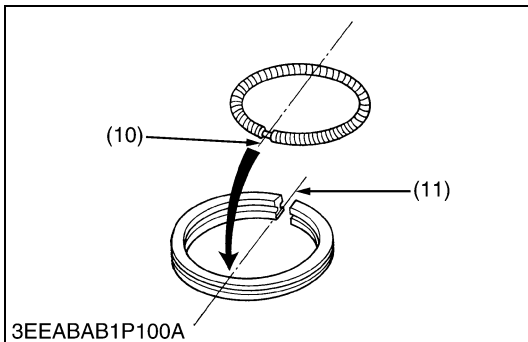
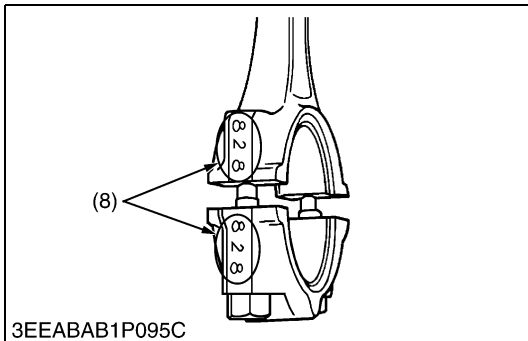
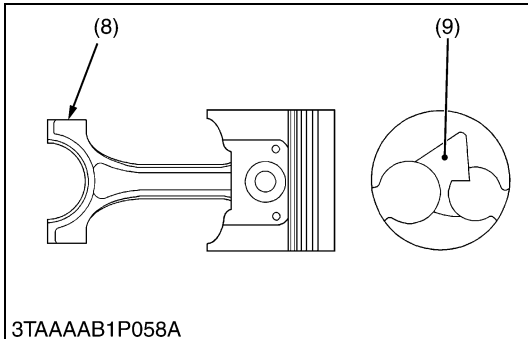
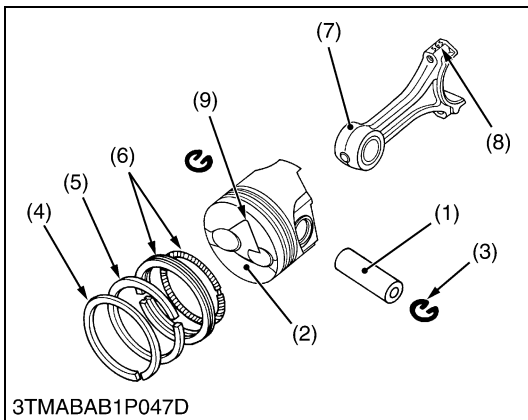

### Piston Ring and Connecting Rod

1. Remove the piston rings (4), (5), (6) using a piston ring tool (Code No. 07909-32121).
2. Remove the piston pin (1), and separate the connecting rod (7) from the piston (2).

#### (When reassembling)

- When installing the ring, assemble the rings so that the manufacturer's mark (12) near the gap faces the top of the piston (2).
- When installing the oil ring (6) onto the piston (2), place the expander joint (10) on the opposite side of the oil ring gap (11).
- Apply engine oil to the piston pin.
- When installing the connecting rod (7) to the piston (2), immerse the piston (2) in 80 °C (176 °F) oil for 10 to 15 minutes and insert the piston pin (1) to the piston (2).

#### NOTE

- When installing the connecting rod (7) to the piston (2), align the mark (8) on the connecting rod (7) to the fan-shaped concave (9).
- Mark the same number on the connecting rod (7) and the piston (2) so as not to change the combination.

- |                          |                          |
|--------------------------|--------------------------|
| (1) Piston Pin           | (7) Connecting Rod       |
| (2) Piston               | (8) Mark                 |
| (3) Piston Pin Snap Ring | (9) Fan-Shaped Concave   |
| (4) Top Ring             | (10) Expander Joint      |
| (5) Second Ring          | (11) Oil Ring Gap        |
| (6) Oil Ring             | (12) Manufacturer's Mark |

W1026376

### (D) Crankshaft

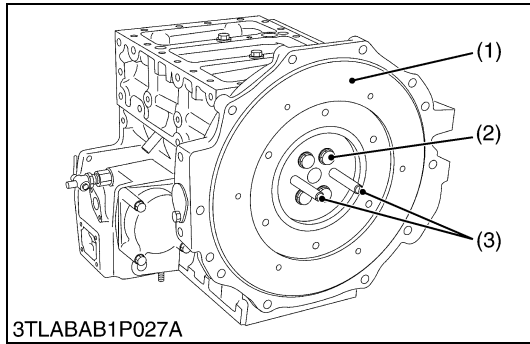

#### Flywheel

1. Fit the stopper to the flywheel (1).
2. At first, remove two pieces of the flywheel screws (2).
3. Insert two pieces of the flywheel guide screws (3) in the holes.
4. Remove the all flywheel screws (2).
5. Remove the flywheel (1) slowly along the flywheel guide screws (3).

#### (When reassembling)

- Insert two pieces of the flywheel guide screws.
- Check to see that there are no metal particles left on the flywheel mounting surfaces.
- Apply engine oil to the threads and the undercut surface of the flywheel bolt and fit the bolt.

Tightening torque	Flywheel screws	98.0 to 107.8 N·m 10.0 to 11.0 kgf·m 72.3 to 79.5 ft-lbs
-------------------	-----------------	--

- (1) Flywheel  
(2) Flywheel Screw

- (3) Flywheel Guide Screws

W1026863

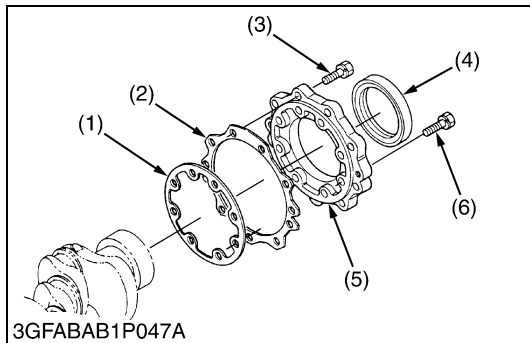

#### Bearing Case Cover

1. Remove the bearing case cover mounting screws. First, remove inside screws (6) and then outside screws (3).
2. Screw two removed screws into the screw hole of bearing case cover (5) to remove it.

#### ■ IMPORTANT

- The length of inside screws and outside screws are different. Do not take a mistake using inside screws and outside screws.

#### (When reassembling)

- Fit the bearing case gasket (1) and the bearing case cover gasket (2) with correct directions.
- Install the bearing case cover (5) to position the casting mark "UP" on it upward.
- Apply engine oil to the oil seal lip and take care that it is not rolled when installing.
- Tighten the bearing case cover mounting screws with even force on the diagonal line.

Tightening torque	Bearing case cover mounting screw	23.5 to 27.5 N·m 2.4 to 2.8 kgf·m 17.4 to 20.3 ft-lbs
-------------------	-----------------------------------	---

- (1) Bearing Case Gasket  
(2) Bearing Case Cover Gasket  
(3) Bearing Case Cover Mounting Screw  
(4) Oil Seal  
(5) Bearing Case Cover  
(6) Bearing Case Cover Mounting Screw  
(a) Upside

W10292140

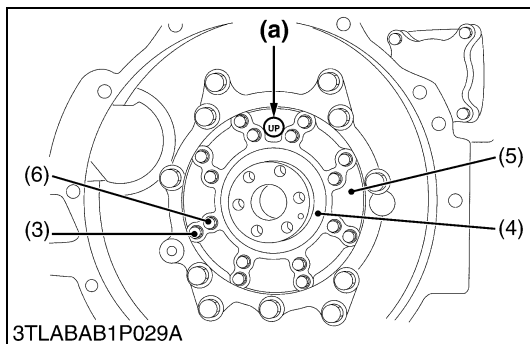
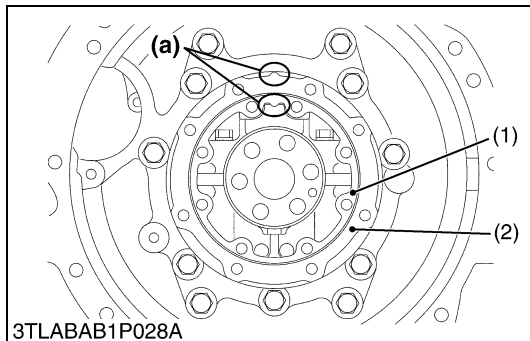

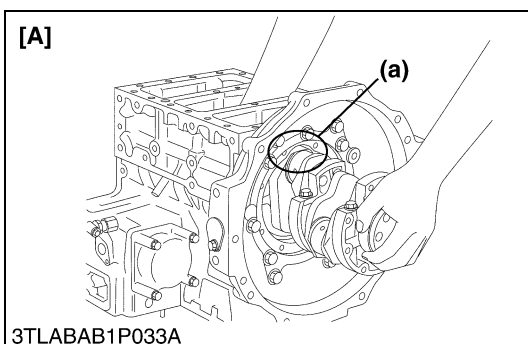
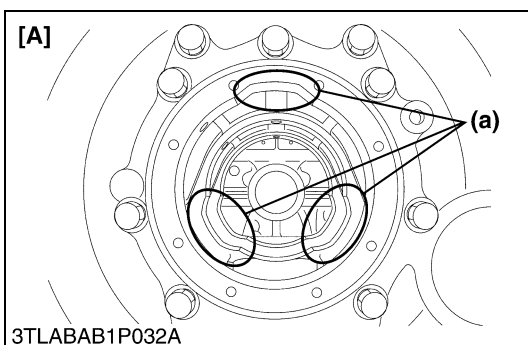
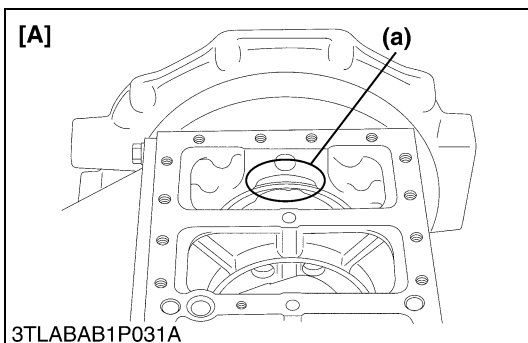
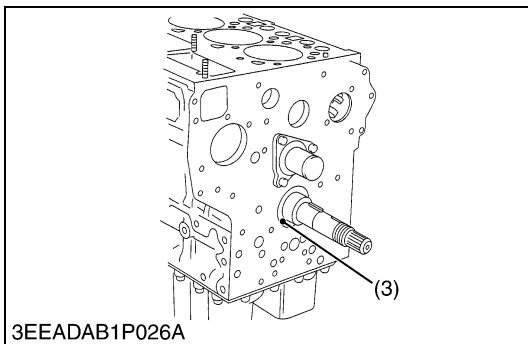
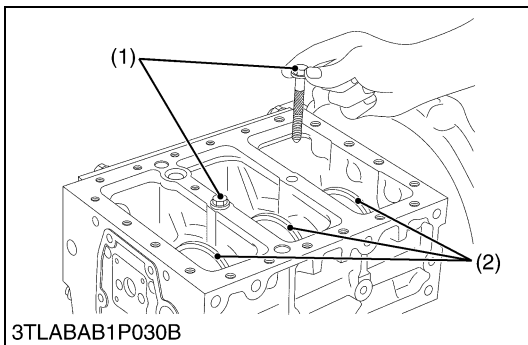

## Crankshaft

### NOTE

- Before disassembling, check the side clearance of crankshaft. Also check it during reassembling.

### For D1503-M, D1703-M and V2203-M

1. Remove the main bearing case screw 2 (1).
2. Pull out the crankshaft assembly, taking care not to damage the crankshaft bearing 1 (3).

### For D1803-M

1. Remove the main bearing case screw 2 (1).
2. Turn the crankshaft to set the crank pin of the third cylinder to the bottom dead center. Then draw out the crankshaft until the crank pin of the second cylinder comes to the center of the third cylinder.
3. Turn the crankshaft by 2.09 rad (120 °) counterclockwise to set the crank pin of the second cylinder to the bottom dead center. Draw out the crankshaft until the crank pin of the first cylinder comes to the center of the third cylinder.
4. Repeat the above steps to draw out all the crankshaft.

### For V2403-M

1. Remove the main bearing case screw 2 (1).
2. Turn the crankshaft to set the crank pin of the 4th cylinder to the horizontal directions (Right or Left). Then draw out all the crankshaft, holding the crank pins to the horizontal directions (Right or Left).

### (When reassembling)

### IMPORTANT

- Install the crankshaft sub assembly, aligning the screw hole of main bearing case 2 (2) with the screw hole of cylinder block.
- When tightening the main bearing case screw 2, apply oil to the screw and screw by hand before tightening the specific torque.

If not smooth to screw by hand, align the screw holes between the cylinder block and the main bearing case.

Tightening torque	Main bearing case screws	68.6 to 73.5 N·m
	2	7.0 to 7.5 kgf·m 50.6 to 54.2 ft·lbs

- (1) Main Bearing Case Screw 2
- (2) Main Bearing Case 2
- (3) Crankshaft Bearing 1

(a) Cut place for removing and installing the crankshaft  
[A] D1803-M

W1066311

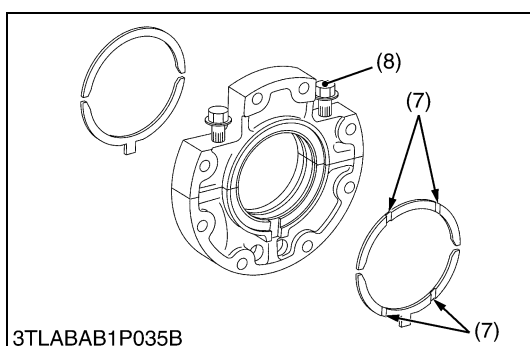
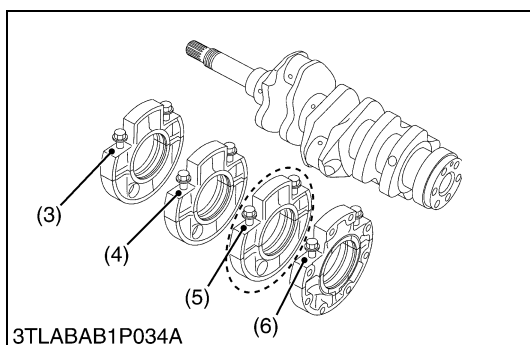
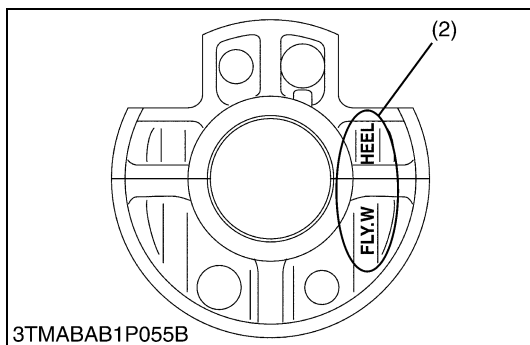
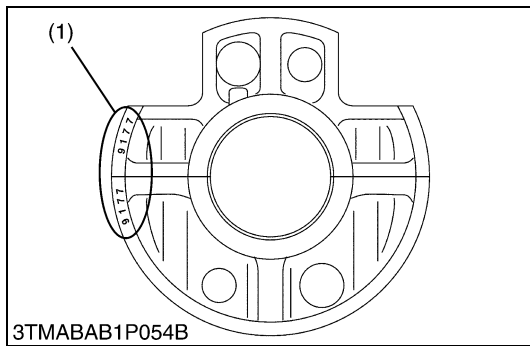
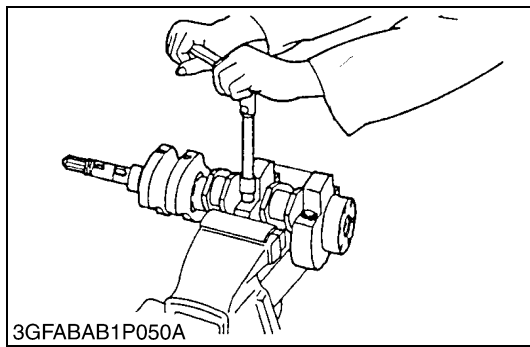

### Main Bearing Case Assembly

1. Remove the two main bearing case screws 1 (8), and remove the main bearing case assembly being careful with thrust bearing and crankshaft bearing.

2. Remove the main bearing case 1, 2 as above.

#### (When reassembling)

- Clean the oil passage in the main bearing case.
- Apply clean engine oil on the bearings.
- Install the main bearing case assemblies in the original positions. Since diameters of main bearing cases vary, install them in order of markings (A, B for 3 cylinders and A, B, C for 4 cylinders) from the gear case side.
- Match the alignment numbers (1) and mark (2) on the main bearing case.
- When installing the main bearing case 1 and 2, face the mark "FLYWHEEL" to the flywheel.
- Install the thrust bearing with its oil groove facing (7) outward.
- Confirm that the main bearing case moves smoothly after tightening the main bearing case screw 1 (8) to the specified torque.

Tightening torque	Main bearing case screw 1	46.1 to 50.9 N·m 4.7 to 5.2 kgf·m 34.0 to 37.6 ft·lbs
-------------------	---------------------------	---

- |                      |                          |
|----------------------|--------------------------|
| (1) Alignment Number | (5) C                    |
| (2) Alignment Mark   | (6) No Mark              |
| (3) A                | (7) Oil Groove           |
| (4) B                | (8) Main Bearing Screw 1 |

W1027366



### (3) Servicing

#### (A) Cylinder Head and Valves

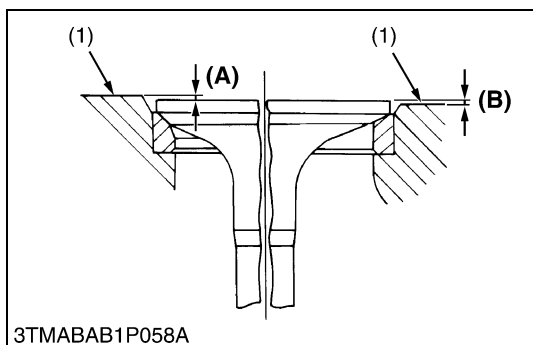
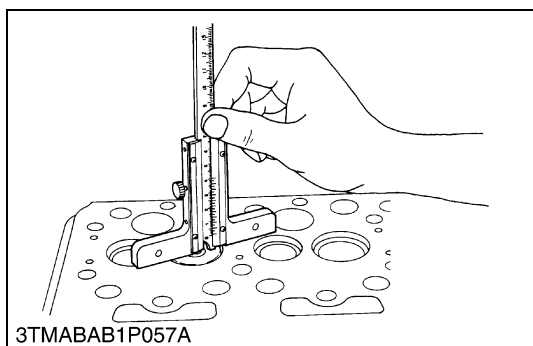
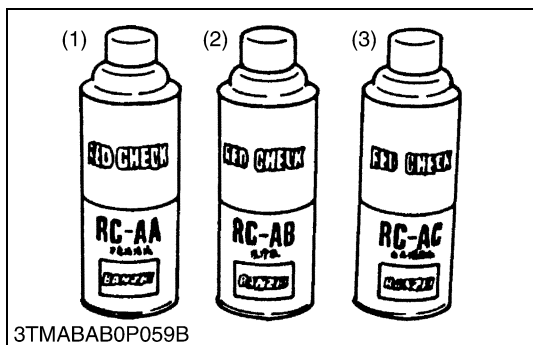
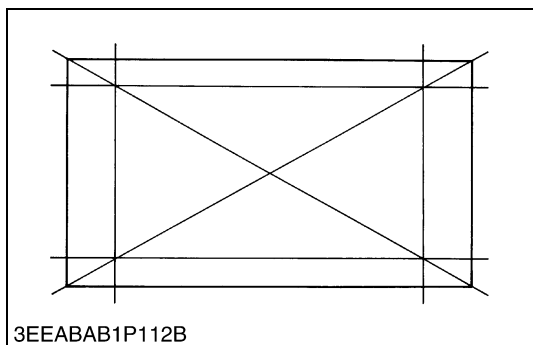
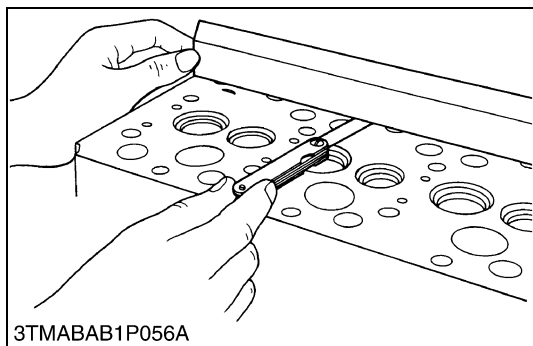

#### Cylinder Head Surface Flatness

1. Clean the cylinder head surface.
2. Place a straightedge on the cylinder head's four sides and two diagonal as shown in the figure.
3. Measure the clearance with a feeler gauge.
4. If the measurement exceeds the allowable limit, correct it with a surface grinder.

■ **IMPORTANT**

- Do not place the straightedge on the combustion chamber.
- Be sure to check the valve recessing after correcting.

Cylinder head surface flatness	Factory spec.	0.05 mm / 500 mm 0.0020 in. / 19.69 in.
--------------------------------	---------------	--

W1027737

#### Cylinder Head Flaw

1. Prepare an air spray red check (Code No. 07909-31371).
2. Clean the surface of the cylinder head with detergent (2).
3. Spray the cylinder head surface with the red permeative liquid (1). Leave it five to ten minutes after spraying.
4. Wash away the red permeative liquid on the cylinder head surface with the detergent (2).
5. Spray the cylinder head surface with white developer (3).
6. If flawed, it can be identified as red marks.

- (1) Red Permeative Liquid  
(2) Detergent

- (3) White Developer

W1076542

#### Valve Recessing

1. Clean the cylinder head surface, valve face and valve seat.
2. Insert the valve into the valve guide.
3. Measure the valve recessing with a depth gauge.
4. If the measurement exceeds the allowable limit, replace the valve.
5. If it still exceeds the allowable limit after replacing the valve, correct the valve seat face of the cylinder head with a valve seat cutter (Code No. 07909-33102) or valve seat grinder.
6. Then, correct the cylinder head surface with a surface grinder, or replace the cylinder head.

Valve recessing	Factory spec.	0.05 (protrusion) to 0.15 (recessing) mm 0.0020 (protrusion) to 0.0059 (recessing) in.
	Allowable limit	0.40 (recessing) mm 0.0157 (recessing) in.

- (1) Cylinder Head Surface

- (A) Recessing  
(B) Protrusion

W1076880

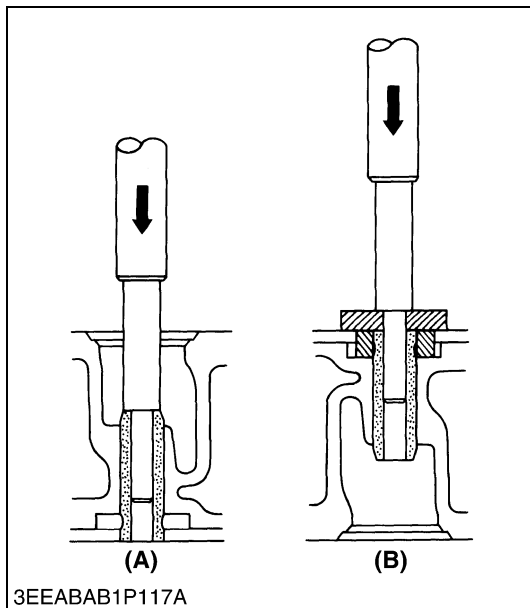
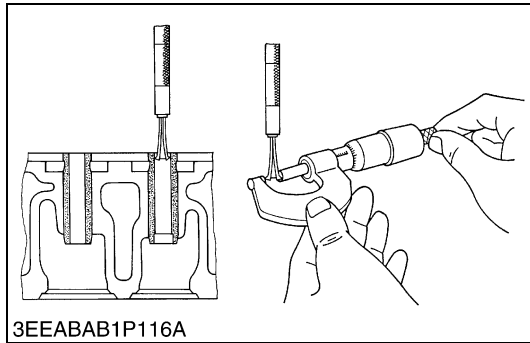
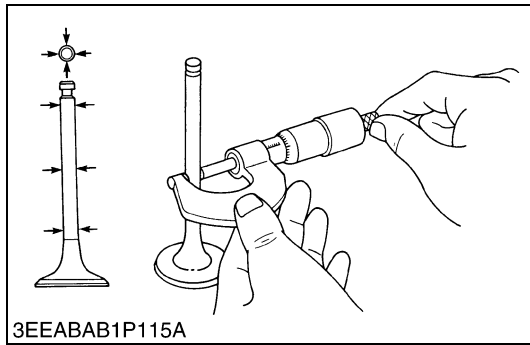

### Clearance between Valve Stem and Valve Guide

1. Remove carbon from the valve guide section.
2. Measure the valve stem O.D. with an outside micrometer.
3. Measure the valve guide I.D. with a small hole gauge, and calculate the clearance.
4. If the clearance exceeds the allowable limit, replace the valves.  
If it still exceeds the allowable limit, replace the valve guide.

Clearance between valve stem and guide	Factory spec.	0.040 to 0.070 mm 0.00157 to 0.00276 in.
	Allowable limit	0.1 mm 0.0039 in.

Valve stem O.D.	Factory spec.	7.960 to 7.975 mm 0.31339 to 0.31398 in.
Valve guide I.D.	Factory spec.	8.015 to 8.030 mm 0.31555 to 0.31614 in.

W1077495

### Replacing Valve Guide

#### (When removing)

1. Press out the used valve guide using a valve guide replacing tool.

#### (When installing)

1. Clean a new valve guide and valve guide bore, and apply engine oil to them.
2. Press in a new valve guide using a valve guide replacing tool.
3. Ream precisely the I.D. of the valve guide to the specified dimension.

Valve guide I.D. (Intake and exhaust)	Factory spec.	8.015 to 8.030 mm 0.31555 to 0.31614 in.
--	---------------	---

#### ■ IMPORTANT

- Do not hit the valve guide with a hammer during replacement.

(A) When Removing

(B) When Installing

W1027889



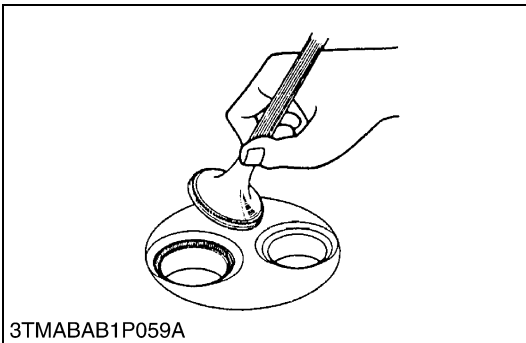

### Valve Seating

1. Coat the valve face lightly with prussian blue and put the valve on its seat to check the contact.
2. If the valve does not seat all the way around the valve seat or the valve contact is less than 70 %, correct the valve seating as follows.
3. If the valve contact does not comply with the reference value, replace the valve or correct the contact of valve seating.

(1) Correct  
(2) Incorrect

(3) Incorrect

W1028219

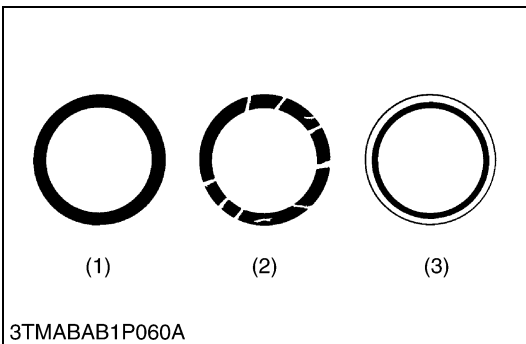

### Correcting Valve and Valve Seat

#### NOTE

- Before correcting the valve and seat, check the valve stem and the I.D. of valve guide section, and repair them if necessary.
- After correcting the valve seat, be sure to check the valve recessing.

#### 1) Correcting Valve

1. Correct the valve with a valve refacer.

#### 2) Correcting Valve Seat

1. Slightly correct the seat surface with a 1.047 rad (60 °) (intake valve) or 0.785 rad (45 °) (exhaust valve) seat cutter (Code No. 07909-33102).
2. Resurface the seat surface with a 0.523 rad (30 °) valve seat cutter to intake valve seat and with a 0.262 rad (15 °) valve seat cutter to exhaust valve seat so that the width is close to specified valve seat width (2.12 mm, 0.0835 in.)
3. After resurfacing the seat, inspect for even valve seating, apply a thin film of compound between the valve face and valve seat, and fit them with valve lapping tool.
4. Check the valve seating with prussian blue. The valve seating surface should show good contact all the way around.

(a) Identical Dimensions

(A) Check Correct

(b) Valve Seat Width

(B) Correct Seat Width

(c) 0.523 rad (30 °) or 0.262 rad (15 °)

(C) Check Contact

(d) 0.262 rad (15 °) or 0.523 rad (30 °)

(e) 0.785 rad (45 °) or 1.047 rad (60 °)

W1028350

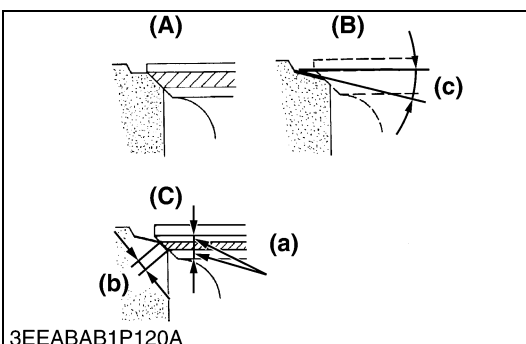
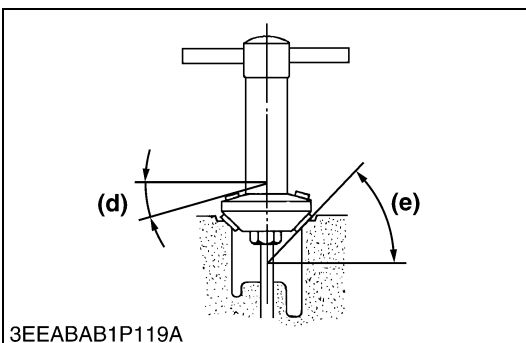
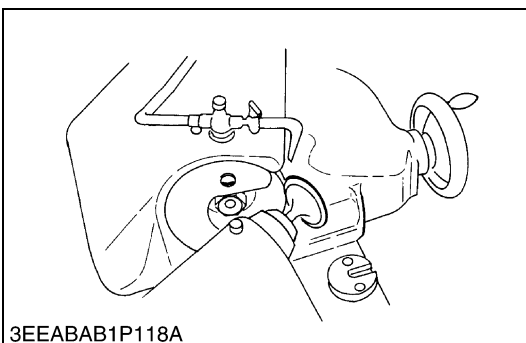

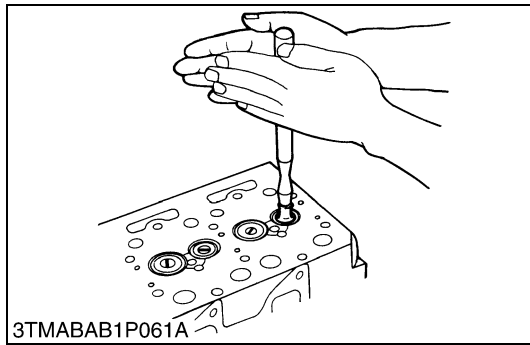

### Valve Lapping

1. Apply compound evenly to the valve lapping surface.
2. Insert the valve into the valve guide. Lap the valve onto its seat with a valve flapper or screwdriver.
3. After lapping the valve, wash the compound away and apply oil, then repeat valve lapping with oil.
4. Apply prussian blue to the contact surface to check the seated rate. If it is less than 70 %, repeat valve lapping again.

#### ■ IMPORTANT

- When valve lapping is performed, be sure to check the valve recessing and adjust the valve clearance after assembling the valve.

W1028814

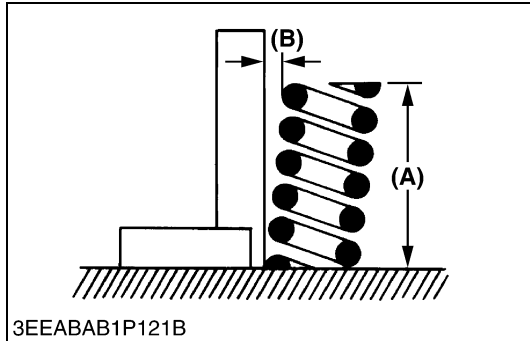

### Free Length and Tilt of Valve Spring

1. Measure the free length (A) of valve spring with vernier calipers. If the measurement is less than the allowable limit, replace it.
2. Put the valve spring on a surface plate, place a square on the side of the valve spring.
3. Check to see if the entire side is in contact with the square. Rotate the valve spring and measure the maximum tilt (B). Check the entire surface of the valve spring for scratches. If there is any defect, replace it.

Free length (A)	Factory spec.	41.7 to 42.2 mm 1.6417 to 1.6614 in.
	Allowable limit	41.2 mm 1.6220 in.

Tilt (B)	Allowable limit	1.0 mm 0.039 in.
----------	-----------------	---------------------

(A) Length

(B) Tilt

W1028935

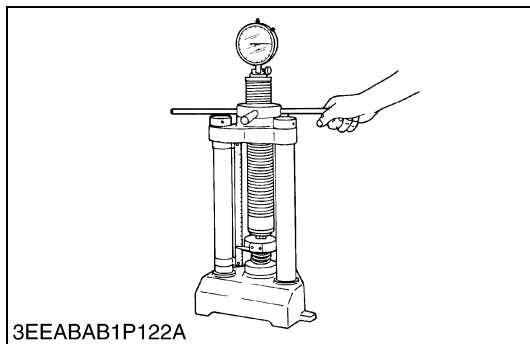

### Valve Spring Setting Load

1. Place the valve spring on a tester and compress it to the same length it is actually compressed in the engine.
2. Read the compression load on the gauge.
3. If the measurement is less than the allowable limit, replace it.

Setting load / Setting length	Factory spec.	117.6 N / 35 mm 12.0 kgf / 35 mm 26.4 lbs / 1.3780 in.
	Allowable limit	100.0 N / 35 mm 10.2 kgf / 35 mm 22.5 lbs / 1.3780 in.

W1078436

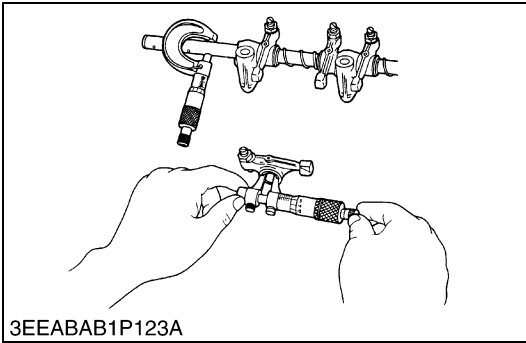

3EEABAB1P123A

### **Oil Clearance between Rocker Arm and Rocker Arm Shaft**

1. Measure the rocker arm shaft O.D. with an outside micrometer.
2. Measure the rocker arm I.D. with an inside micrometer, and then calculate the oil clearance.
3. If the oil clearance exceeds the allowable limit, replace the rocker arm and measure the oil clearance again. If it still exceeds the allowable limit, replace also the rocker arm shaft.

Oil clearance between rocker arm and rocker arm shaft	Factory spec.	0.016 to 0.045 mm 0.00063 to 0.00177 in.
	Allowable limit	0.10 mm 0.0039 in.

Rocker arm shaft O.D.	Factory spec.	13.973 to 13.984 mm 0.55012 to 0.55055 in.
-----------------------	---------------	---

Rocker arm I.D.	Factory spec.	14.000 to 14.018 mm 0.55118 to 0.55189 in.
-----------------	---------------	---

W1029150

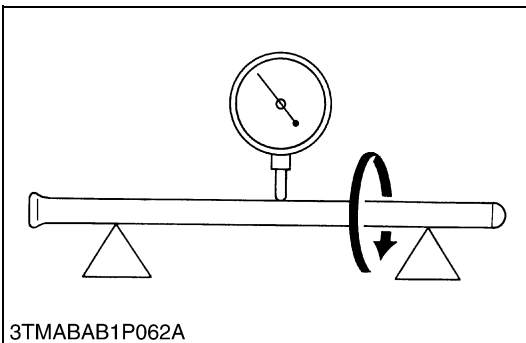

3TMABAB1P062A

### **Push Rod Alignment**

1. Place the push rod on V blocks.
2. Measure the push rod alignment.
3. If the measurement exceeds the allowable limit, replace the push rod.

Push rod alignment	Allowable limit	0.25 mm 0.0098 in.
--------------------	-----------------	-----------------------

W1029290

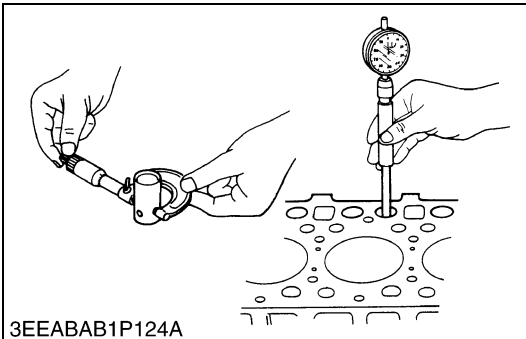

3EEABAB1P124A

### **Oil Clearance between Tappet and Tappet Guide Bore**

1. Measure the tappet O.D. with an outside micrometer.
2. Measure the I.D. of the tappet guide bore with a cylinder gauge, and calculate the oil clearance.
3. If the oil clearance exceeds the allowable limit or the tappet is damaged, replace the tappet.

Oil Clearance between tappet and tappet guide bore	Factory spec.	0.020 to 0.062 mm 0.00079 to 0.00244 in.
	Allowable limit	0.07 mm 0.0028 in.

Tappet O.D.	Factory spec.	23.959 to 23.980 mm 0.94327 to 0.94410 in.
-------------	---------------	---

Tappet guide bore I.D.	Factory spec.	24.000 to 24.021 mm 0.94488 to 0.94571 in.
------------------------	---------------	---

W1028249

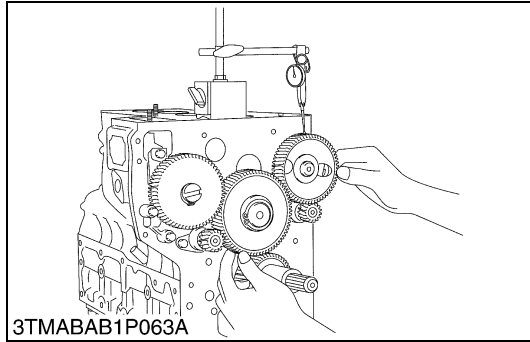
**(B) Timing Gears, Camshaft and Fuel Camshaft****Timing Gear Backlash**

1. Set a dial indicator (lever type) with its tip on the gear tooth.
2. Move the gear to measure the backlash, holding its mating gear.
3. If the backlash exceeds the allowable limit, check the oil clearance of the shafts and the gear.
4. If the oil clearance is proper, replace the gear.

Backlash between idle gear and crank gear	Factory spec.	0.0415 to 0.1122 mm 0.00163 to 0.00442 in.
	Allowable limit	0.15 mm 0.0059 in.

Backlash between idle gear and cam gear	Factory spec.	0.0415 to 0.1154 mm 0.00163 to 0.00454 in.
	Allowable limit	0.15 mm 0.0059 in.

Backlash between idle gear and injection pump gear	Factory spec.	0.0415 to 0.1154 mm 0.00163 to 0.00454 in.
	Allowable limit	0.15 mm 0.0059 in.

Backlash between crank gear and oil pump gear	Factory spec.	0.0415 to 0.1090 mm 0.00163 to 0.00429 in.
	Allowable limit	0.15 mm 0.0059 in.

**[for V2203-M and V2403-M only]**

Backlash between idle gear and balancer gear (IN. side)	Factory spec.	0.0350 to 0.1160 mm 0.00138 to 0.00457 in.
	Allowable limit	0.15 mm 0.0059 in.

Backlash between cam gear and balancer gear (EX. gear)	Factory spec.	0.0350 to 0.1160 mm 0.00138 to 0.00457 in.
	Allowable limit	0.15 mm 0.0059 in.

W1029564

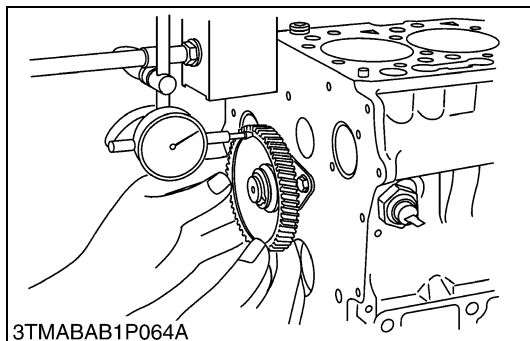
**Idle Gear Side Clearance**

1. Set a dial indicator with its tip on the idle gear.
2. Measure the side clearance by moving the idle gear to the front and rear.
3. If the measurement exceeds the allowable limit, replace the idle gear collar.

Idle gear side clearance	Factory spec.	0.12 to 0.48 mm 0.0047 to 0.0189 in.
	Allowable limit	0.9 mm 0.0354 in.

W1029843

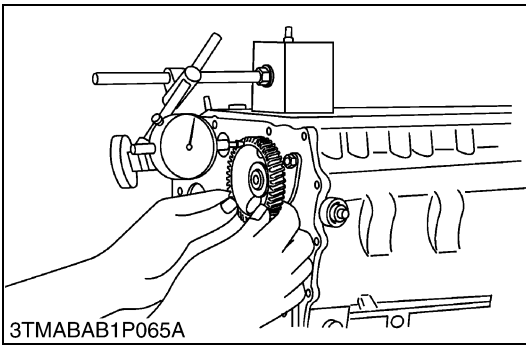

### Camshaft Side Clearance

1. Set a dial indicator with its tip on the camshaft.
2. Measure the side clearance by moving the cam gear to the front and rear.
3. If the measurement exceeds the allowable limit, replace the camshaft stopper.

Camshaft side clearance	Factory spec.	0.07 to 0.22 mm 0.0028 to 0.0087 in.
	Allowable limit	0.30 mm 0.0118 in.

W1030012

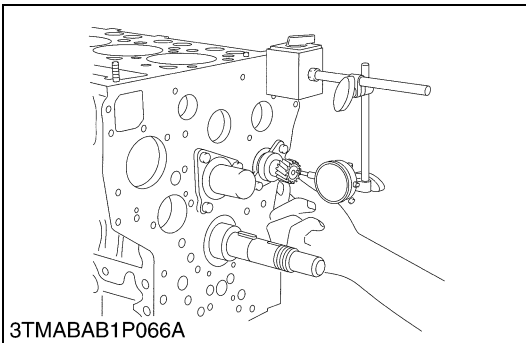

### Balancer Shaft Side Clearance (for V2203-M and V2403-M)

1. Set a dial indicator with tip on the balancer shaft.
2. Measure the side clearance by moving the balancer shaft to the front and rear.
3. If the measurement exceeds the allowable limit, replace the balancer shaft.

Side clearance of balancer shaft	Factory spec.	0.07 to 0.22 mm 0.0028 to 0.0087 in.
	Allowable limit	0.3 mm 0.0118 in.

W1030111

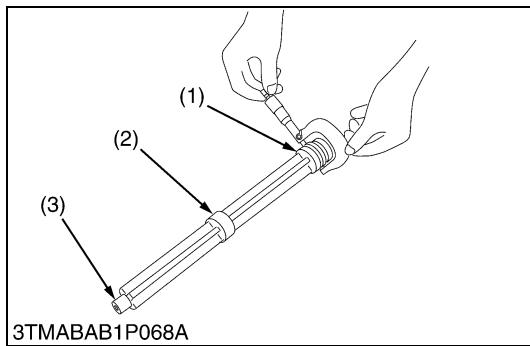
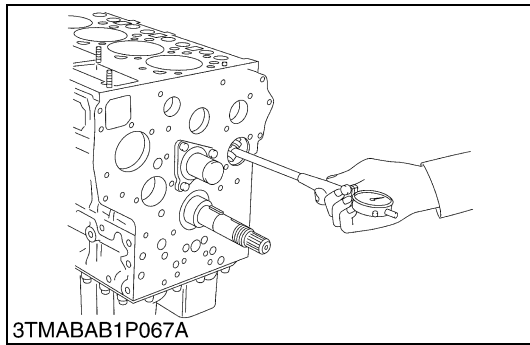

### Oil Clearance of Balancer Shaft Journal (for V2203-M and V2403-M)

1. Measure the balancer shaft journal O.D. with an outside micrometer.
2. Measure the cylinder block bore I.D. for balancer shaft with an inside micrometer or cylinder gauge.
3. If the clearance exceeds the allowable limit, replace the balancer shaft.

Oil clearance of balancer shaft journal 1	Factory spec.	0.030 to 0.111 mm 0.00118 to 0.00437 in.
	Allowable limit	0.2 mm 0.0079 in.

Balancer shaft journal 1 O.D.	Factory spec.	43.934 to 43.950 mm 1.72968 to 1.73031 in.
Balancer shaft bearing 1 I.D.	Factory spec.	43.980 to 44.045 mm 1.73149 to 1.73405 in.

Oil clearance of balancer shaft journal 2	Factory spec.	0.030 to 0.111 mm 0.00118 to 0.00437 in.
	Allowable limit	0.2 mm 0.0079 in.

Balancer shaft journal 2 O.D.	Factory spec.	41.934 to 41.950 mm 1.65094 to 1.65157 in.
Balancer shaft bearing 2 I.D.	Factory spec.	41.980 to 42.045 mm 1.65275 to 1.65531 in.

Oil clearance of balancer shaft journal 3	Factory spec.	0.020 to 0.094 mm 0.00079 to 0.00370 in.
	Allowable limit	0.2 mm 0.0079 in.

Balancer shaft journal 3 O.D.	Factory spec.	21.947 to 21.960 mm 0.86405 to 0.86456 in.
Balancer shaft bearing 3 I.D.	Factory spec.	21.980 to 22.041 mm 0.86535 to 0.86775 in.

(1) Balancer Shaft Journal 1  
(2) Balancer Shaft Journal 2

(3) Balancer Shaft Journal 3

W1030206

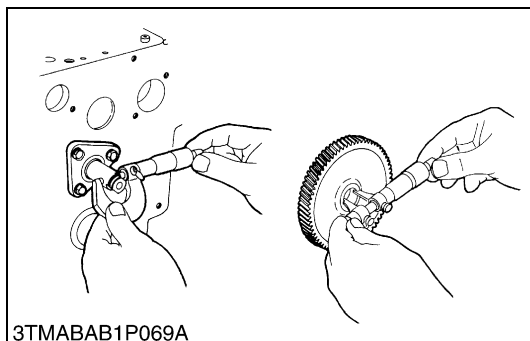

### Oil Clearance between Idle Gear Shaft and Idle Gear Bushing

1. Measure the idle gear shaft O.D. with an outside micrometer.
2. Measure the idle gear bushing I.D. with an inside micrometer, and calculate the oil clearance.
3. If the oil clearance exceeds the allowable limit, replace the bushing.

Clearance between idle gear shaft and idle gear bushing	Factory spec.	0.025 to 0.066 mm 0.00098 to 0.00260 in.
	Allowable limit	0.1 mm 0.0039 in.

Idle gear shaft O.D.	Factory spec.	37.959 to 37.975 mm 1.49445 to 1.49508 in.
Idle gear bushing I.D.	Factory spec.	38.000 to 38.025 mm 1.49606 to 1.49704 in.

W1030933

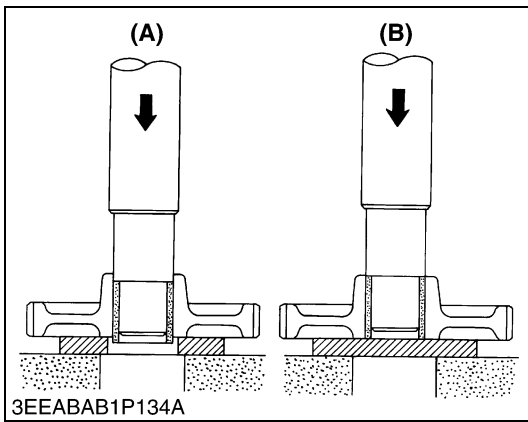

### Replacing Idle Gear Bushing

#### (A) (When removing)

1. Using an idle gear bushing replacing tool, press out the used bushing.

#### (B) (When installing)

1. Clean a new idle gear bushing and idle gear bore, and apply engine oil to them.
2. Using an idle gear bushing replacing tool, press in a new bushing (service parts) to the specified dimension. (See figure.)

W1031083

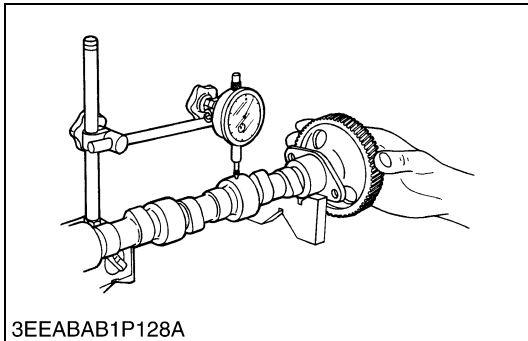

### Camshaft Alignment

1. Support the camshaft with V blocks on the surface plate at both end journals.
2. Set a dial indicator with its tip on the intermediate journal.
3. Measure the camshaft alignment.
4. If the measurement exceeds the allowable limit, replace the camshaft.

Camshaft alignment	Allowable limit	0.01 mm 0.0004 in.
--------------------	-----------------	-----------------------

W1031413

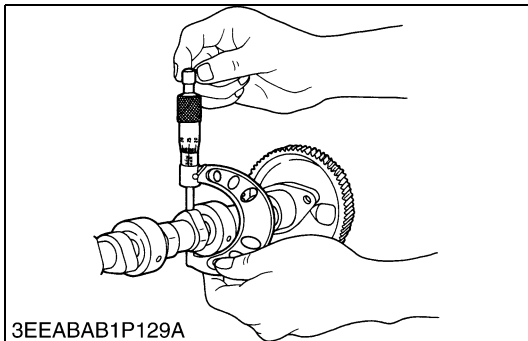

### Cam Height

1. Measure the height of the cam at its highest point with an outside micrometer.
2. If the measurement is less than the allowable limit, replace the camshaft.

Cam height of intake	Factory spec.	33.90 mm 1.3346 in.
	Allowable limit	33.85 mm 1.3327 in.

Cam height of exhaust	Factory spec.	33.90 mm 1.3346 in.
	Allowable limit	33.85 mm 1.3327 in.

W1031532



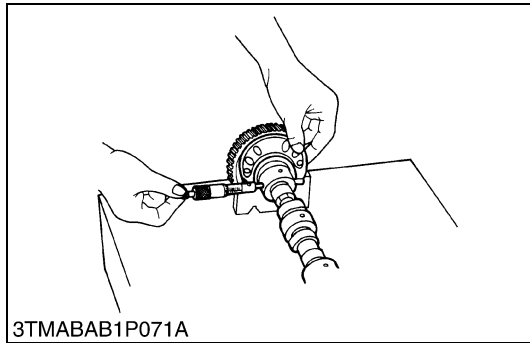
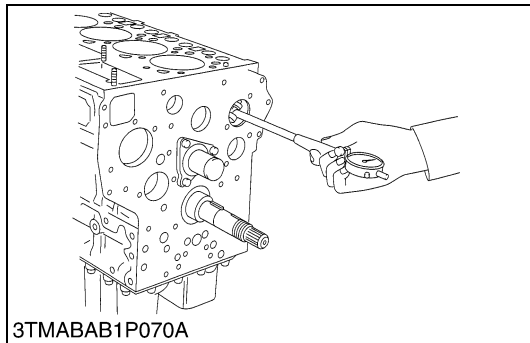

### (C) Piston and Connecting Rod

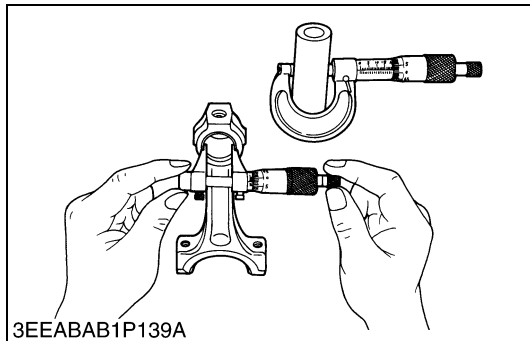
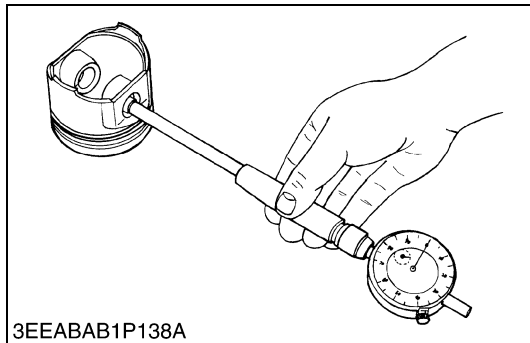

### Oil Clearance of Camshaft Journal

1. Measure the camshaft journal O.D. with an outside micrometer.
2. Measure the cylinder block bore I.D. for camshaft with a cylinder gauge, and calculate the oil clearance.
3. If the oil clearance exceeds the allowable limit, replace the camshaft.

Oil clearance of camshaft journal	Factory spec.	0.050 to 0.091 mm 0.00197 to 0.00358 in.
	Allowable limit	0.15 mm 0.0059 in.

Camshaft journal O.D.	Factory spec.	39.934 to 39.950 mm 1.57221 to 1.57284 in.
Cylinder block bore I.D.	Factory spec.	40.000 to 40.025 mm 1.57480 to 1.57579 in.

W1031662

### Piston Pin Bore I.D.

1. Measure the piston pin bore I.D. in both the horizontal and vertical directions with a cylinder gauge.
2. If the measurement exceeds the allowable limit, replace the piston.

Piston pin bore I.D.	Factory spec.	25.000 to 25.013 mm 0.98425 to 0.98476 in.
	Allowable limit	25.05 mm 0.9862 in.

W1031817

### Oil Clearance between Piston Pin and Small End Bushing

1. Measure the piston pin O.D. where it contacts the bushing with an outside micrometer.
2. Measure the small end bushing I.D. with an inside micrometer, and calculate the oil clearance.
3. If the oil clearance exceeds the allowable limit, replace the bushing. If it still exceeds the allowable limit, replace the piston pin.

Oil clearance between piston pin and small end bushing	Factory spec.	0.014 to 0.038 mm 0.00055 to 0.00150 in.
	Allowable limit	0.15 mm 0.0059 in.

Piston pin O.D.	Factory spec.	25.002 to 25.011 mm 0.98433 to 0.98468 in.
Small end bushing I.D.	Factory spec.	25.025 to 25.040 mm 0.98523 to 0.98582 in.

W1031982

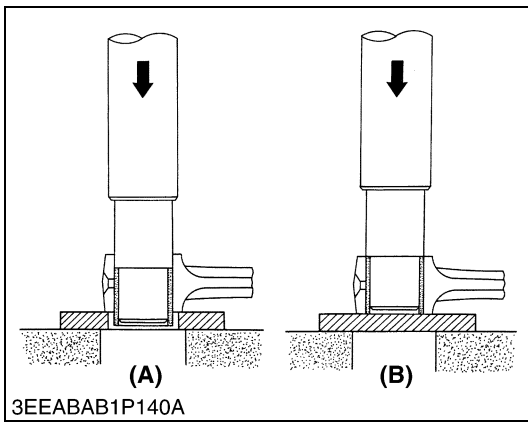

### Replacing Connecting Rod Small End Bushing

#### (A) (When removing)

1. Press out the small end bushing with a connecting rod small end bushing replacing tool.

#### (B) (When installing)

1. Clean a new small end bushing and bore, and apply engine oil to them.
2. Press fit a new bushing, taking due care to see that the connecting rod hole matches the bushing hole.

W1032140

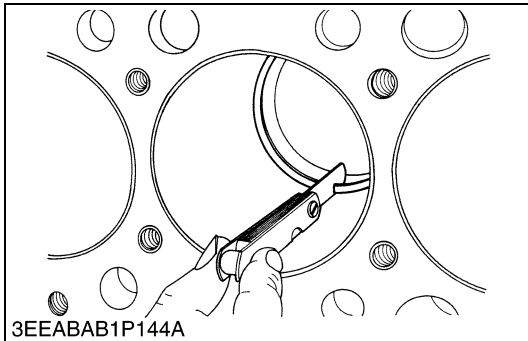

### Piston Ring Gap

1. Insert the piston ring into the lower part of the liner (the least worn out part) with the piston.
2. Measure the ring gap with a feeler gauge.
3. If the gap exceeds the allowable limit, replace the ring.

Top ring	Factory spec.	D1503-M	0.20 to 0.35 mm 0.0079 to 0.0138 in.
		D1703-M D1803-M V2203-M V2403-M	0.20 to 0.40 mm 0.0079 to 0.0157 in.
		Allowable limit	1.25 mm 0.0492 in.

Second ring	Factory spec.	0.30 to 0.45 mm 0.0118 to 0.0179 in.
	Allowable limit	1.25 mm 0.0492 in.

Oil ring	Factory spec.	0.25 to 0.45 mm 0.0098 to 0.0177 in.
	Allowable limit	1.25 mm 0.0492 in.

W1032246

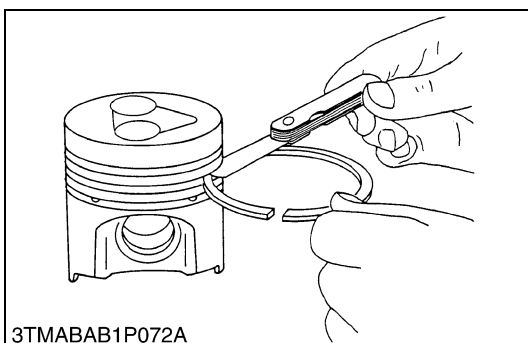

### Clearance between Piston Ring and Groove

1. Remove carbon from the ring grooves.
2. Measure the clearance between the ring and the groove with a feeler gauge.
3. If the clearance exceeds allowable limit, replace the ring since compression leak and oil shortage result.
4. If the clearance still exceeds the allowable limit after replacing the ring, replace the piston.

Second ring	Factory spec.	D1503-M	0.093 to 0.120 mm 0.0037 to 0.0047 in.
		D1703-M D1803-M V2203-M V2403-M	0.093 to 0.128 mm 0.0037 to 0.0050 in.
		Allowable limit	0.2 mm 0.0079 in.

Oil ring	Factory spec.	0.020 to 0.060 mm 0.0008 to 0.0021 in.
	Allowable limit	0.15 mm 0.0059 in.

W1032489

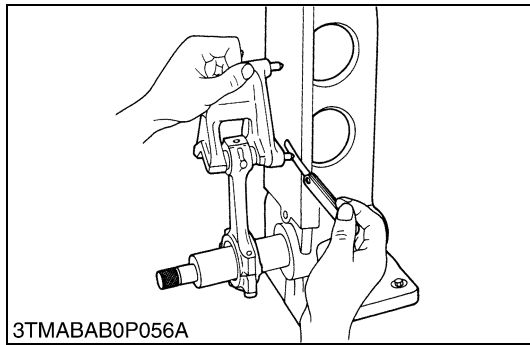

3TMABAB0P056A

### Connecting Rod Alignment

■ **NOTE**

- Since the I.D. of the connecting rod small end bushing is the basis of this check, check bushing for wear beforehand.

1. Install the piston pin into the connecting rod.
2. Install the connecting rod on the connecting rod alignment tool.
3. Put a gauge over the piston pin and move it against the face plate.
4. If the gauge does not fit squarely against the face plate, measure the space between the pin of the gauge and the face plate.
5. If the measurement exceeds the allowable limit, replace the connecting rod.

Connecting rod alignment	Allowable limit	0.05 mm 0.0020 in.
--------------------------	-----------------	-----------------------

W1032720

### (D) Crankshaft

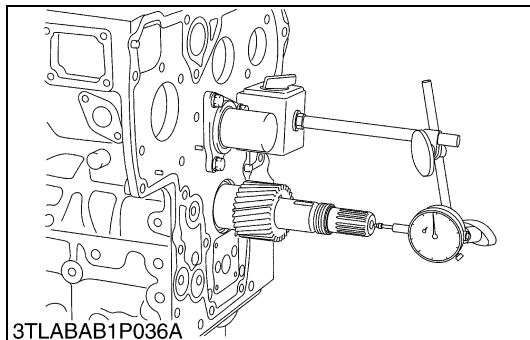

3TLABAB1P036A

### Side Clearance of Crankshaft

1. Move the crankshaft to the flywheel side.
2. Set a dial indicator to the crankshaft.
3. Measure the end play by pulling the crankshaft toward the crank gear.
4. If the measurement exceeds the allowable limit, replace the thrust bearing 1 and 2.

Crankshaft side clearance	Factory spec.	D1503-M D1703-M V2203-M	0.15 to 0.35 mm 0.0059 to 0.0138 in.
		D1803-M V2403-M	0.15 to 0.31 mm 0.0059 to 0.0122 in.
Allowable limit		0.5 mm 0.0197 in.	

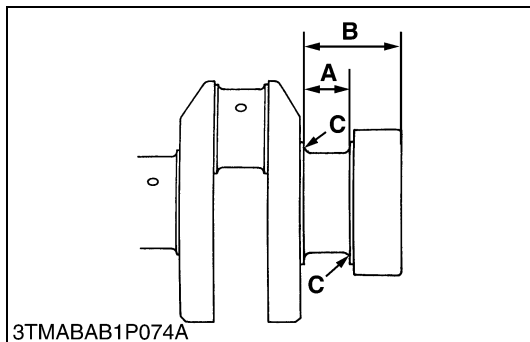

3TMABAB1P074A

### (Reference)

- Oversize dimensions of crankshaft journal

Oversize	0.2 mm 0.008 in.	0.4 mm 0.016 in.
Dimension		
<b>A</b>	26.20 to 26.25 mm 1.0315 to 1.0335 in.	26.40 to 26.45 mm 1.0394 to 1.0413 in.
<b>B</b>	54.5 to 54.7 mm 2.1456 to 2.1535 in.	54.6 to 54.8 mm 2.1496 to 2.1574 in.
<b>C</b>	2.8 to 3.2 mm radius 0.1102 to 0.1260 in. radius	2.8 to 3.2 mm radius 0.1102 to 0.1260 in. radius
(0.8-S) The crankshaft journal must be fine-finished to higher than ∇∇∇∇		

W1032880

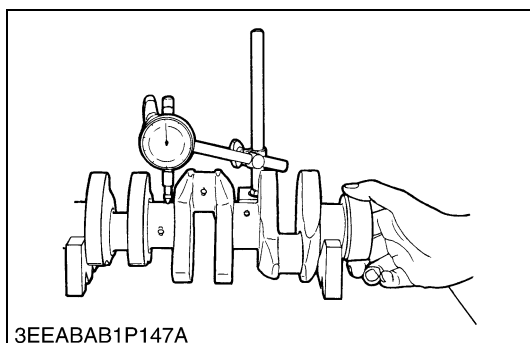

3EEABAB1P147A

### Crankshaft Alignment

1. Support the crankshaft with V blocks on the surface plate and set a dial indicator with its tip on the intermediate journal at right angle.
2. Rotate the crankshaft on the V blocks and get the misalignment (half of the measurement).
3. If the misalignment exceeds the allowable limit, replace the crankshaft.

Crankshaft alignment	Allowable limit	0.02 mm 0.00079 in.
----------------------	-----------------	------------------------

W1033001

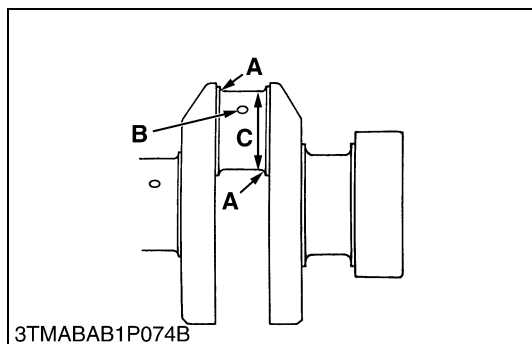
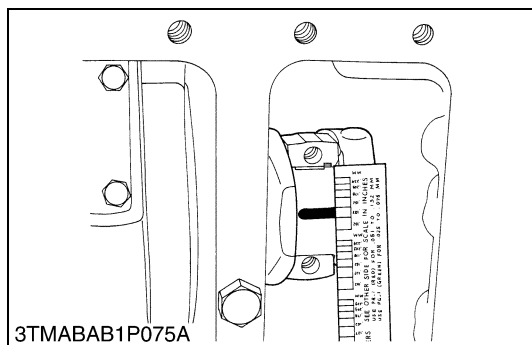

### Oil Clearance between Crankpin and Crankpin Bearing

1. Clean the crankpin and crankpin bearing.
2. Put a strip of plastigage (Code No.: 07909-30241) on the center of the crankpin in each direction as shown in the figure.
3. Install the connecting rod cap and tighten the connecting rod screws to the specified torque, and remove the cap again.
4. Measure the amount of the flattening with the scale, and get the oil clearance.
5. If the oil clearance exceeds the allowable limit, replace the crankpin bearing.
6. If the same size bearing is useless because of the crankpin wear, replace it with an undersize one referring to the table and figure.

#### NOTE

- Never insert the plastigage into the crankpin oil hole.
- Be sure not to move the crankshaft while the connecting rod screws are tightened.

Oil clearance between crankpin and crankpin bearing	Factory spec.	0.025 to 0.087 mm 0.00098 to 0.00343 in.
	Allowable limit	0.2 mm 0.0079 in.

Crankpin O.D.	Factory spec.	46.959 to 46.975 mm 1.84878 to 1.84941 in.
Crankpin bearing I.D.	Factory spec.	47.000 to 47.046 mm 1.85039 to 1.85220 in.

#### (Reference)

- Undersize dimensions of crankpin

Dimension	Undersize	
	0.2 mm 0.008 in.	0.4 mm 0.016 in.
<b>A</b>	3.3 to 3.7 mm radius 0.1299 to 0.1457 in. radius	3.3 to 3.7 mm radius 0.1299 to 0.1457 in. radius
<b>B</b>	1.0 to 1.5 mm radius 0.0394 to 0.0591 in. radius	1.0 to 1.5 mm radius 0.0394 to 0.0591 in. radius
<b>C</b>	46.759 to 46.775 mm 1.84091 to 1.84154 in.	46.559 to 46.575 mm 1.83303 to 1.83366 in.
(0.8-S)		
The crankpin must be fine-finished to higher than ∇∇∇∇		

W1033106

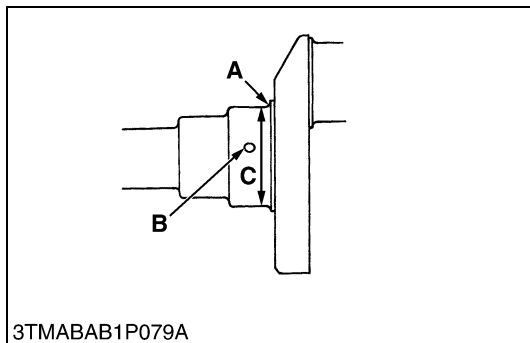
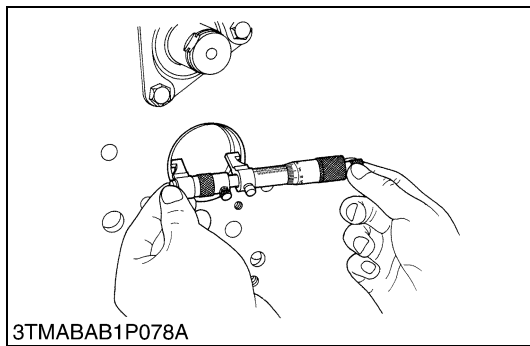
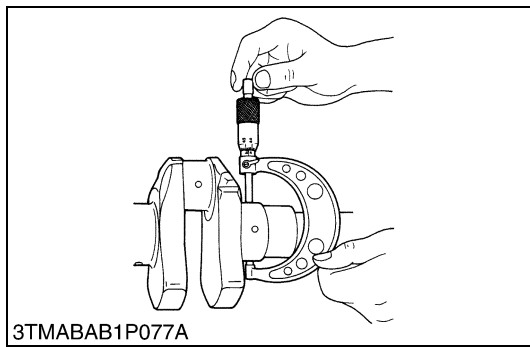

**Oil Clearance between Crankshaft Journal and Crankshaft Bearing 1**

1. Measure the O.D. of the crankshaft journal with an outside micrometer.
2. Measure the I.D. of the crankshaft bearing 1 with an inside micrometer, and calculate oil clearance.
3. If the clearance exceeds the allowable limit, replace the crankshaft bearing 1.
4. If the same size bearing is useless because of the crankshaft journal wear, replace it with an undersize one referring to the table and figure.

Oil clearance between crankshaft journal and crankshaft bearing 1	Factory spec.	0.040 to 0.118 mm 0.00157 to 0.00409 in.
	Allowable limit	0.2 mm 0.0079 in.

Crankshaft journal O.D.	Factory spec.	D1503-M V1703-M V2203-M	51.921 to 51.940 mm 2.0441 to 2.0449 in.
		D1803-M V2403-M	59.921 to 59.940 mm 2.35909 to 2.35984 in.
Crankshaft bearing 1 I.D.	Factory spec.	D1503-M V1703-M V2203-M	51.980 to 52.039 mm 2.0464 to 2.0488 in.
		D1803-M V2403-M	59.980 to 60.039 mm 2.36142 to 2.36374 in.

**(Reference)**

- Undersize dimensions of crankshaft journal

Undersize		0.2 mm 0.008 in.	0.4 mm 0.016 in.
		Dimension	
A	2.8 to 3.2 mm radius 0.1102 to 0.1260 in. radius		2.8 to 3.2 mm radius 0.1102 to 0.1260 in. radius
	1.0 to 1.5 mm radius 0.0394 to 0.0591 in. radius		1.0 to 1.5 mm radius 0.0394 to 0.0591 in. radius
C	D1503-M V1703-M V2203-M	51.721 to 51.740 mm 2.0363 to 2.0370 in.	51.521 to 51.540 mm 2.0284 to 2.0291 in.
	D1803-M V2403-M	59.721 to 59.740 mm 2.35122 to 2.35197 in.	59.521 to 59.540 mm 2.34335 to 2.34409 in.
(0.8-S)			
The crankshaft journal must be fine-finished to higher than ∇∇∇∇			

W1033717

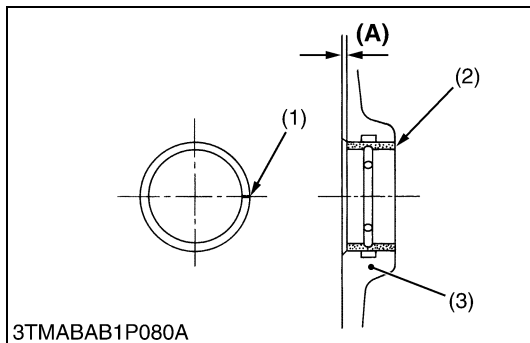

**Replacing Crankshaft Bearing 1**

**(When removing)**

1. Press out the used crankshaft bearing 1 using a crankshaft bearing 1 replacing tool.

**(When installing)**

1. Clean a new crankshaft bearing 1 and crankshaft journal bore, and apply engine oil to them.
2. Using a crankshaft bearing 1 replacing tool, press in a new bearing 1 (2) so that its seam (1) directs toward the exhaust manifold side.

Dimension (A)	Factory spec.	4.2 to 4.5 mm 0.1654 to 0.1772 in.
---------------	---------------	---------------------------------------

- (1) Seam
- (2) Crankshaft Bearing 1
- (3) Cylinder Block

W1033946

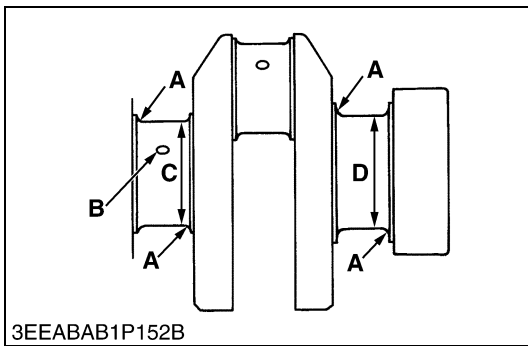
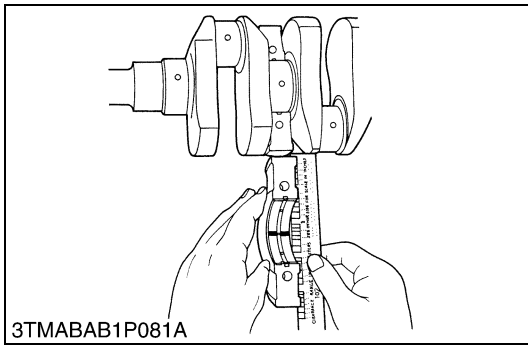

### Oil Clearance between Crankshaft Journal and Crankshaft Bearing 2

1. Put a strip of plastigage on the center of the journal.
2. Install the bearing case and tighten the bearing case screws 1 to the specified torque, and remove the bearing case again.
3. Measure the amount of the flattening with the scale and get the oil clearance.
4. If the clearance exceeds the allowable limit, replace the crankshaft bearing 2.
5. If the same size bearing is useless because of the crankshaft journal wear, replace it with an undersize one referring to the table and figure.

■ **NOTE**

- **Be sure not to move the crankshaft while the bearing case screws are tightened.**

Oil clearance between crankshaft and crankshaft bearing 2	Factory spec.	0.040 to 0.104 mm 0.00157 to 0.00409 in.
	Allowable limit	0.20 mm 0.0079 in.

Crankshaft O.D.	Factory spec.	D1503-M V1703-M V2203-M	51.921 to 51.940 mm 2.0441 to 2.0449 in.
		D1803-M V2403-M	59.921 to 59.940 mm 2.35909 to 2.35984 in.
Crankshaft bearing 2 I.D.	Factory spec.	D1503-M V1703-M V2203-M	51.980 to 52.025 mm 2.0465 to 2.0482 in.
		D1803-M V2403-M	59.980 to 60.025 mm 2.36142 to 2.36318 in.

**(Reference)**

- Undersize dimensions of crankshaft journal

Undersize		0.2 mm 0.008 in.	0.4 mm 0.016 in.
		Dimension	
<b>A</b>		2.8 to 3.2 mm radius 0.1102 to 0.1260 in. radius	2.8 to 3.2 mm radius 0.1102 to 0.1260 in. radius
<b>B</b>		1.0 to 1.5 mm radius 0.0394 to 0.0591 in. radius	1.0 to 1.5 mm radius 0.0394 to 0.0591 in. radius
<b>C, D</b>	D1503-M V1703-M V2203-M	51.721 to 51.740 mm 2.0363 to 2.0370 in.	51.521 to 51.540 mm 2.0284 to 2.0291 in.
	D1803-M V2403-M	59.721 to 59.740 mm 2.35122 to 2.35197 in.	59.521 to 59.540 mm 2.34335 to 2.34409 in.
(0.8-S) The crankshaft journal must be fine-finished to higher than ∇∇∇∇			

W1083821

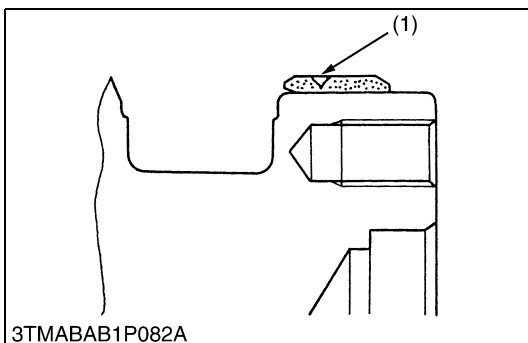

### Crankshaft Sleeve Wear

1. Check the wear on the crankshaft sleeve (1).
2. If the wear exceeds the allowable limit or when the engine oil leaks, replace the crankshaft sleeve.

Wear of sleeve	Allowable limit	0.1 mm 0.0004 in.
----------------	-----------------	----------------------

(1) Crankshaft Sleeve

W1033354

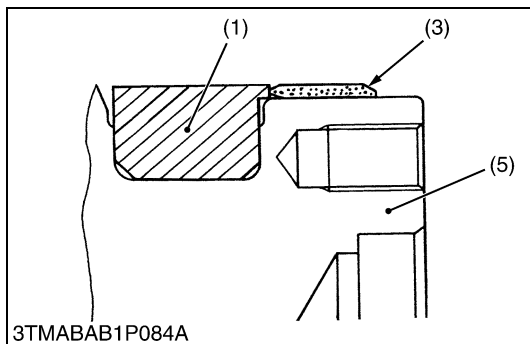
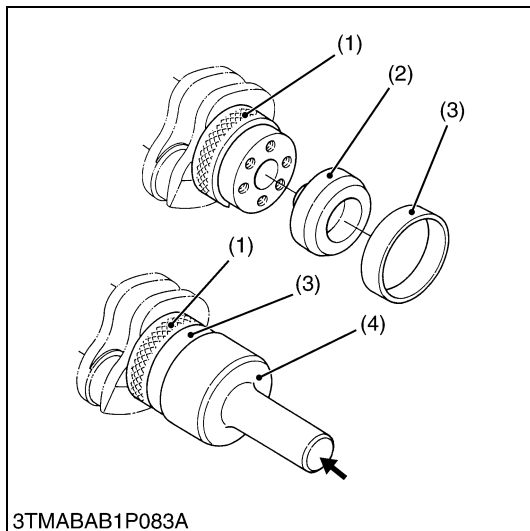

### Replacing Crankshaft Sleeve

1. Remove the used crankshaft sleeve using a special-use puller set (Code No.: 07916-32091).
2. Set the sleeve guide (2) to the crankshaft.
3. Set the stopper (1) to the crankshaft as shown in figure.
4. Heat a new sleeve to a temperature between 150 to 200 °C (302 to 392 °F), and fix the sleeve to the crankshaft as shown in figure.
5. Press fit the sleeve using the auxiliary socket for pushing (4).

#### NOTE

- Mount the sleeve with its largely chamfered surface facing outward.

- (1) Stopper
- (2) Sleeve Guide
- (3) Crankshaft Sleeve
- (4) Auxiliary Socket for Pushing
- (5) Crankshaft

W1033503

## (E) Cylinder

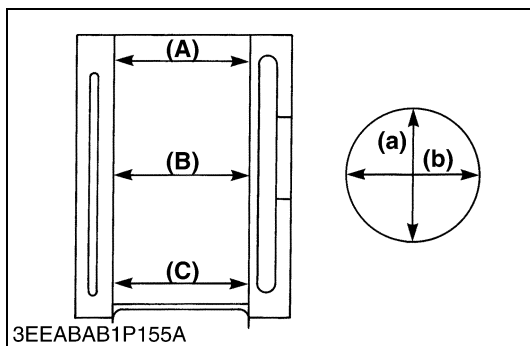
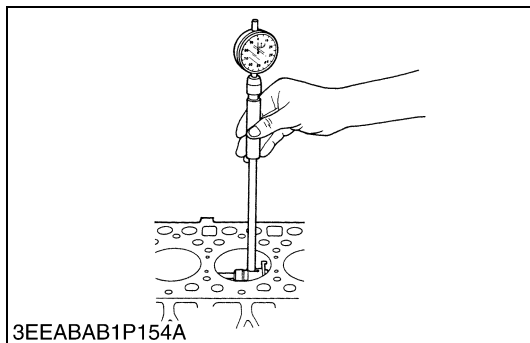

### Cylinder Wear

1. Measure the I.D. of the cylinder at the six positions (see figure) with a cylinder gauge to find the maximum and minimum I.D.'s.
2. Get the difference (Maximum wear) between the maximum and the minimum I.D.'s.
3. If the wear exceeds the allowable limit, bore and hone to the oversize dimension. (Refer to “Correcting Cylinder”.)
4. Visually check the cylinder wall for scratches. If deep scratches are found, the cylinder should be bores. (Refer to “Correcting Cylinder”.)

Cylinder I.D.	Factory spec.	D1503-M	83.000 to 83.022 mm 3.2677 to 3.2686 in.
		D1703-M	
		D1803-M	87.000 to 87.022 mm 3.42519 to 3.42606 in.
		V2203-M V2403-M	
Maximum wear	Allowable limit	D1503-M	+0.15 mm +0.0059 in.
		D1703-M	
		D1803-M	+0.15 mm +0.0059 in.
		V2203-M V2403-M	

- (A) Top
- (B) Middle
- (C) Bottom (Skirt)

- (a) Right-angled to Piston Pin
- (b) Piston Pin Direction

W1034389



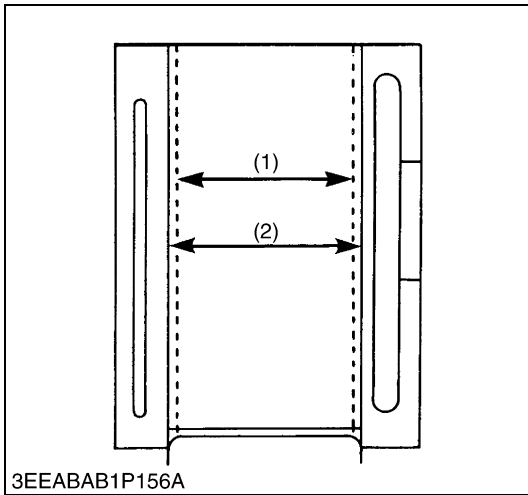

### Correcting Cylinder (Oversize +0.25 mm)

- When the cylinder is worn beyond the allowable limit, bore and hone it to the specified dimension.

Oversize cylinder I.D.	Factory spec.	D1503-M	83.250 to 83.272 mm 3.2776 to 3.2784 in.
		D1703-M D1803-M V2203-M V2403-M	87.250 to 87.272 mm 3.43503 to 3.43590 in.
Maximum wear	Allowable limit	D1503-M	+0.15 mm +0.0059 in.
		D1703-M D1803-M V2203-M V2403-M	+0.15 mm +0.0059 in.
Finishing	Hone to 2.2 to 3.0 mm $\mu$ R max. $\nabla\nabla\nabla$ (0.00087 to 0.00118 in. $\mu$ R max.)		

- Replace the piston and piston rings with oversize (+0.25 mm) ones.

#### ■ NOTE

- When the oversize cylinder is worn beyond the allowable limit, replace the cylinder block with a new one.

(1) Cylinder I.D. (Before Correction)      (2) Oversize Cylinder I.D.

W1034448

## [3] LUBRICATING SYSTEM

### (1) Checking

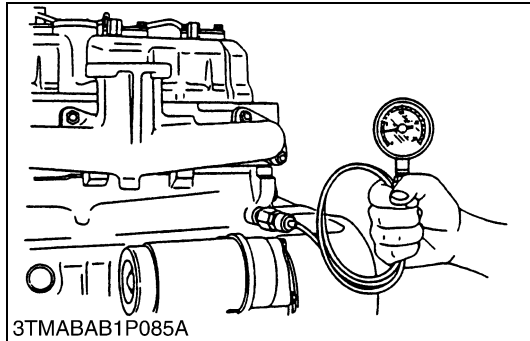

#### Engine Oil Pressure

1. Remove the engine oil pressure switch, and set a oil pressure tester (Code No.: 07916-32032).
2. Start the engine. After warming up, measure the oil pressure of both idling and rated speeds.
3. If the oil pressure is less than the allowable limit, check the following.
  - Engine oil insufficient.
  - Oil pump defective
  - Oil strainer clogged
  - Oil filter cartridge clogged
  - Oil gallery clogged
  - Excessive oil clearance
  - Foreign matter in the relief valve

Engine oil pressure	At idle speed	Allowable limit	More than 49 kPa 0.5 kgf/cm <sup>2</sup> 7 psi
	At rated speed	Factory spec.	294.2 to 441 kPa 3.0 to 4.5 kgf/cm <sup>2</sup> 42.7 to 64 psi
		Allowable limit	245 kPa 2.5 kgf/cm <sup>2</sup> 36 psi

#### (When reassembling)

- After checking the engine oil pressure, tighten the engine oil pressure switch to the specified torque.

W1034952

### (2) Servicing

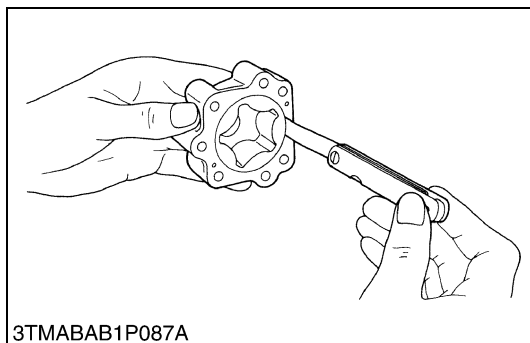
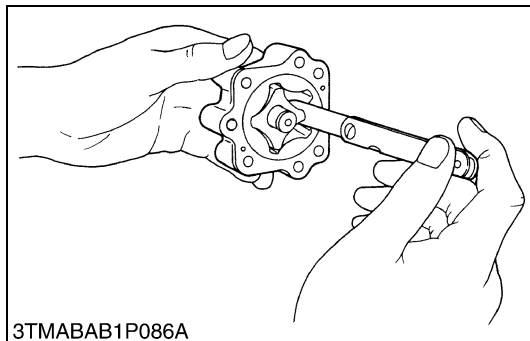

#### Rotor Lobe Clearance

1. Measure the clearance between lobes of the inner rotor and the outer rotor with a feeler gauge.
2. Measure the clearance between the outer rotor and the pump body with a feeler gauge.
3. If the clearance exceeds the factory specifications, replace the oil pump rotor assembly.

Clearance between inner rotor and outer rotor	Factory spec.	0.03 to 0.14 mm 0.0012 to 0.0055 in.
---	---------------	---

Clearance between outer rotor and pump body	Factory spec.	0.11 to 0.19 mm 0.0043 to 0.0075 in.
---	---------------	---

W1035296

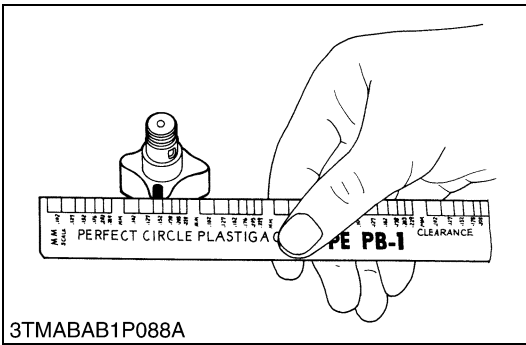

3TMABAB1P088A

### Clearance between Rotor and Cover

1. Put a strip of plastigage (Code No.: 07909-30241) onto the rotor face with grease.
2. Install the cover and tighten the screws.
3. Remove the cover carefully, and measure the width of the press gauge with a sheet of gauge.
4. If the clearance exceeds the factory specifications, replace oil pump rotor assembly.

End clearance between inner rotor and cover	Factory spec.	0.105 to 0.150 mm 0.00413 to 0.00591 in.
---	---------------	---

W1035444

## [4] COOLING SYSTEM

### (1) Checking and Adjusting

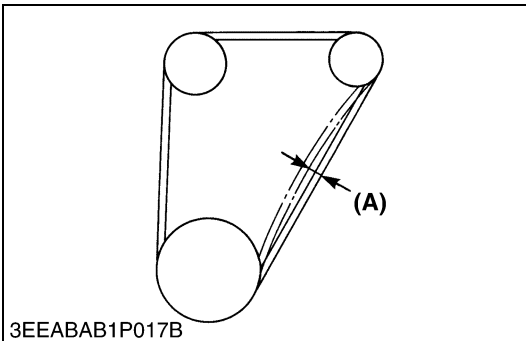

3EEABAB1P017B

### Fan Belt Tension

1. Measure the deflection (**A**), depressing the belt halfway between the fan drive pulley and alternator pulley at specified force (98 N, 10 kgf, 22 lbs).
2. If the measurement is not within the factory specifications, loosen the alternator mounting screws and relocate the alternator to adjust.

Deflection ( <b>A</b> )	Factory spec.	7.0 to 9.0 mm 0.28 to 0.35 in.
-------------------------	---------------	-----------------------------------

W1035667

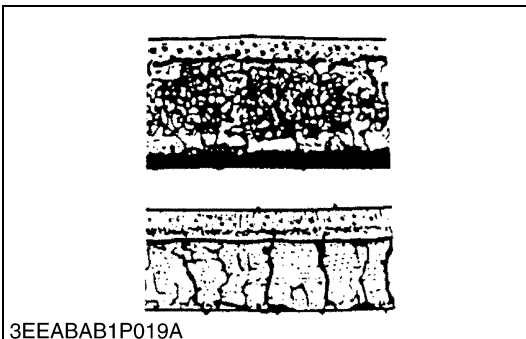

3EEABAB1P019A

### Fan Belt Damage and Wear

1. Check the fan belt for damage.
2. If the fan belt is damaged, replace it.
3. Check if the fan belt is worn and sunk in the pulley groove.
4. If the fan belt is nearly worn out and deeply sunk in the pulley groove, replace it.

W1035758

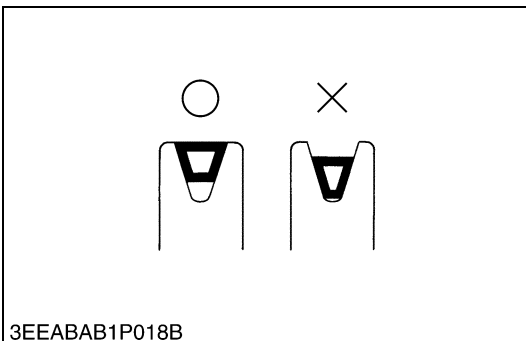

3EEABAB1P018B

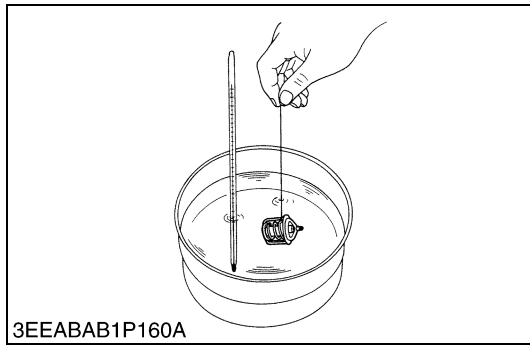

3EEABAB1P160A

### Thermostat Valve Opening Temperature

1. Suspend the thermostat in the water by a string with its end inserted between the valve and seat.
2. Heating the water gradually, read the temperature when the valve opens and leaves the string.
3. Continue heating and read the temperature when the valve opens approx. 6 mm (0.236 in.).
4. If the measurement is not within the factory specifications, replace the thermostat.

Thermostat's valve opening temperature	Factory spec.	69.5 to 72.5 °C 157.1 to 162.5 °F
Temperature at which thermostat completely opens	Factory spec.	85 °C 185 °F

W1035849

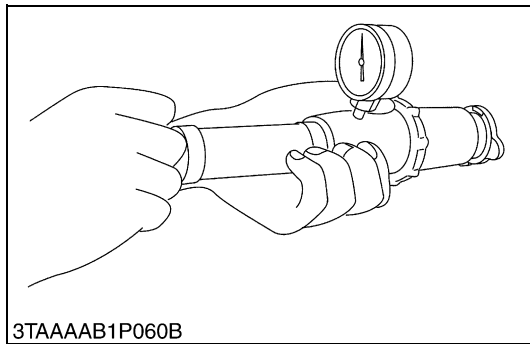

3TAAAB1P060B

### Radiator Cap Air Leakage

#### ⚠ CAUTION

- **When removing the radiator cap, wait at least ten minutes after the engine has stopped and cooled down. Otherwise, hot water may gush out, scalding nearby people.**

1. Set a radiator tester (Code No.: 07909-31551) on the radiator cap.
2. Apply the specified pressure (88 kPa, 0.9 kgf/cm<sup>2</sup>, 13 psi), and measure the time for the pressure to fall to 59 kPa (0.6 kgf/cm<sup>2</sup>, 9 psi).
3. If the measurement is less than the factory specification, replace the radiator cap.

Pressure falling time	Factory spec.	More than 10 seconds for pressure fall from 88 to 59 kPa (from 0.9 to 0.6 kgf/cm <sup>2</sup> , from 13 to 9 psi)
-----------------------	---------------	--

W1036090

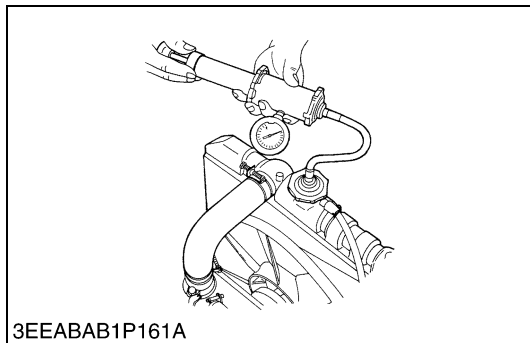

3EEABAB1P161A

### Radiator Water Leakage

1. Pour a specified amount of water into the radiator.
2. Set a radiator tester (Code No. 07909-31551) with an adapter (BANZAI Code No. RCT-2A-30S) and raise the water pressure to the specified pressure.
3. Check the radiator for water leaks.
4. For water leak from the pinhole, repair with the radiator cement. When water leak is excessive, replace the radiator.

Radiator water leakage test pressure	Factory spec.	137 kPa 1.4 kgf/cm <sup>2</sup> 20 psi
--------------------------------------	---------------	--

W10389070

## [5] FUEL SYSTEM

### (1) Checking and Adjusting

#### (A) Injection Pump

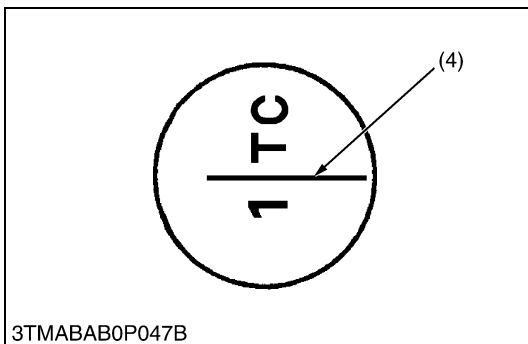
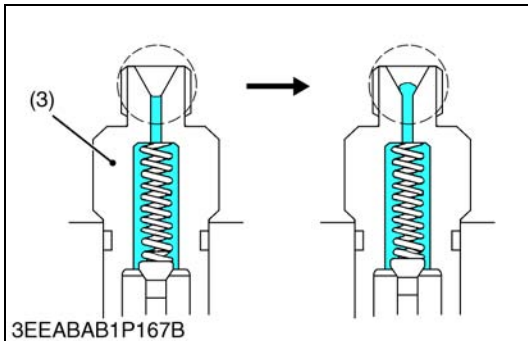
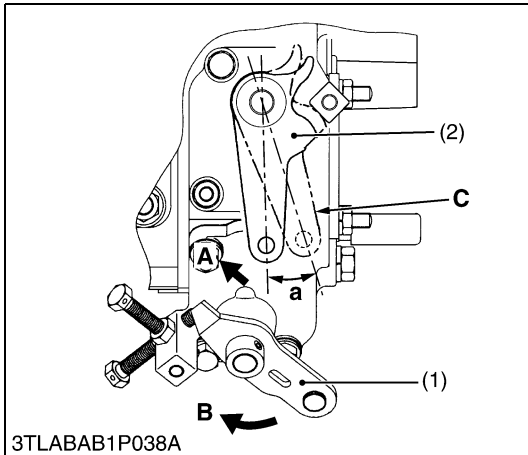
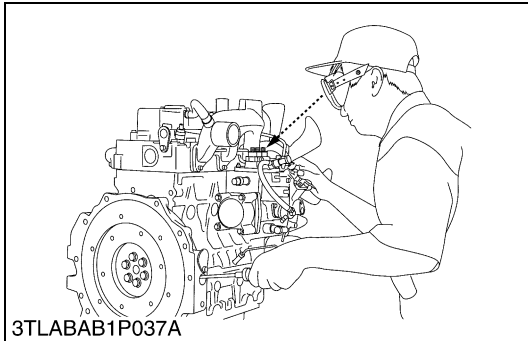

#### Injection Timing

1. Remove the stop solenoid.
2. Remove the injection pipes and nozzle.
3. Set the speed control lever to maximum fuel discharge position.

#### (Reference)

- Turn the flywheel with screwdriver.

#### NOTE

- For V2203-M and V2403-M, the pumps have a displacement angle. In adjusting the injection timing, pull the stop lever from its free position by  $0.267 \pm 0.035$  rad ( $15.3 \pm 2^\circ$ ) toward the stop position.

4. Turn the flywheel counterclockwise (facing the flywheel) until the fuel fills up to the hole of the delivery valve holder for 1st cylinder.
5. Turn the flywheel further and stop turning when the fuel begins to flow over, to get the present injection timing.
6. (The flywheel has mark 1TC and four lines indicating every  $0.087$  rad ( $5^\circ$ ) of crank angle from  $0.175$  rad ( $10^\circ$ ) to  $0.436$  rad ( $25^\circ$ ) before mark 1TC) Calculate the angle which the center of the window points out. If the calculation differs from specified injection timing, add or remove the shim to adjust.

#### (Injection Timing)

$0.297$  to  $0.331$  rad ( $17^\circ$  to  $19^\circ$ ) B.T.D.C.

#### NOTE

- The sealant is applied to both sides of the soft metal gasket shim. The liquid gasket is not required for assembling.
- Shims are available in thickness of  $0.20$  mm,  $0.25$  mm and  $0.30$  mm. Combine these shims for adjustments.
- Addition or reduction of shim ( $0.05$  mm,  $0.0020$  in.) delays or advances the injection timing by approx.  $0.0087$  rad ( $0.5^\circ$ ).
- In disassembling and replacing, be sure to use the same number of new gasket shims with the same thickness.

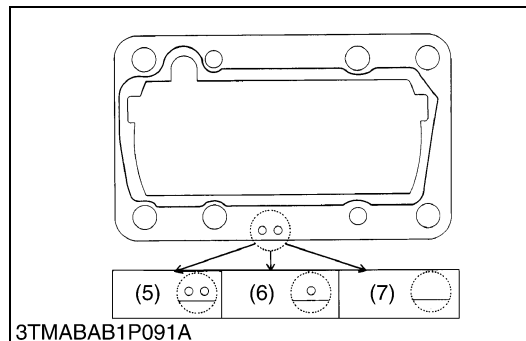

(1) Speed Control Lever

(2) Stop Lever

(3) Delivery Valve Holder

(4) Timing Mark

(5) 2-Holes:  $0.20$  mm (Shim)

(6) 1-hole:  $0.25$  mm (Shim)

(7) Without hole:  $0.30$  mm (Shim)

(A) To STOP Position

(B) To Max. Speed Position

(C) Stop Lever in Free Position

(a)  $0.267 \pm 0.035$  rad ( $15.3 \pm 2^\circ$ )

W1036402

**(B) Injection Nozzle****CAUTION**

- Check the nozzle injection pressure and condition after confirming that there is nobody standing in the direction the fume goes. If the fume from the nozzle directly contacts the human body, cells may be destroyed and blood poisoning may be caused.

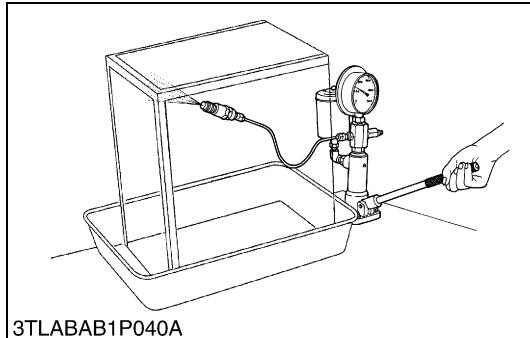
**Nozzle Injection Pressure**

1. Set the injection nozzle to the nozzle tester.
2. Slowly move the tester handle to measure the pressure at which fuel begins jetting out from the nozzle.
3. If the measurement is not within the factory specifications, replace the injection nozzle assembly.

Fuel injection pressure	Factory spec.	13.73 to 14.71 MPa 140 to 150 kgf/cm <sup>2</sup> 1991 to 2133 psi
-------------------------	---------------	--

W1037197

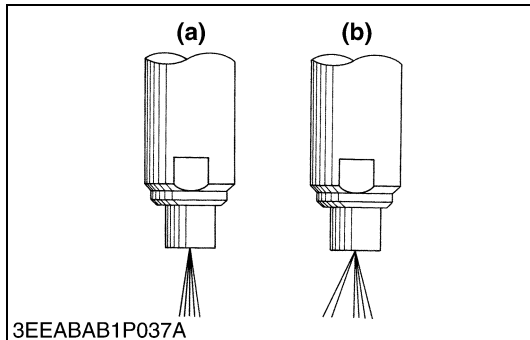
**Nozzle Spraying Condition**

1. Set the injection nozzle to a nozzle tester (Code No. 07909-31361), and check the nozzle spraying condition.
2. If the spraying condition is defective, replace the injection nozzle assembly.

(a) Good

(b) Bad

W1037394

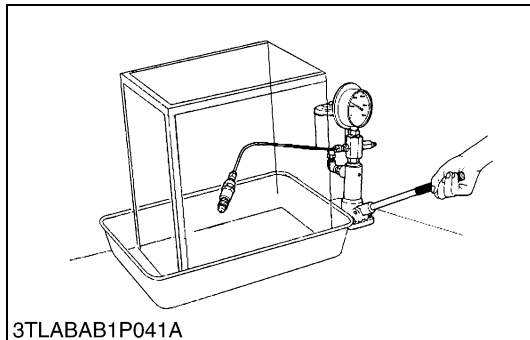
**Valve Seat Tightness**

1. Set the injection nozzle to a nozzle tester (Code No. 07909-31361).
2. Raise the fuel pressure, and keep at 12.75 MPa (130 kgf/cm<sup>2</sup>, 1849 psi) for 10 seconds.
3. If any fuel leak is found, replace the injection nozzle assembly.

Valve seat tightness	Factory spec.	No fuel leak at 12.75 MPa 130 kgf/cm <sup>2</sup> 1849 psi
----------------------	---------------	---

W1088949

# 2 CLUTCH



# MECHANISM

## CONTENTS

1. FEATURE .....	2-M1
------------------	------

# 1. FEATURE

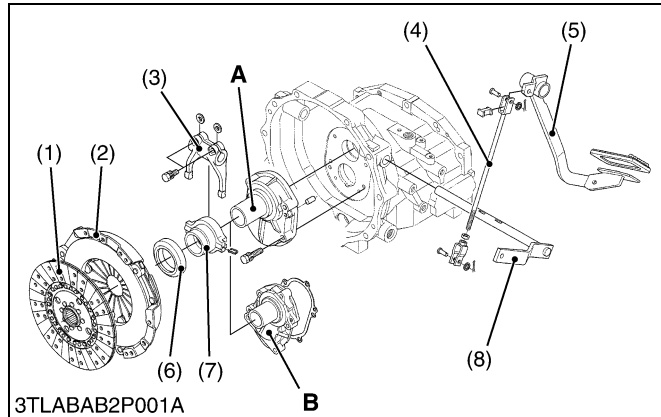

The dry single plate with diaphragm spring type clutch is adapted for all models.

This clutch is operated with the hanging type pedal, and the pedal (5) and release fork (3) have been linked as shown in figure.

- |                             |                       |
|-----------------------------|-----------------------|
| (1) Clutch Disc             | (10) Pressure Plate   |
| (2) Pressure Plate Assembly | (11) Diaphragm Spring |
| (3) Release Fork            | (12) Main Shaft       |
| (4) Clutch Pedal Rod        | (13) Clutch Cover     |
| (5) Clutch Pedal            | (14) PTO Shaft        |
| (6) Release Bearing         |                       |
| (7) Release Hub             |                       |
| (8) Clutch Lever Shaft      |                       |
| (9) Flywheel                |                       |

**A : Manual Transmission and  
GST Model**  
**B : HST Model**

W1012642

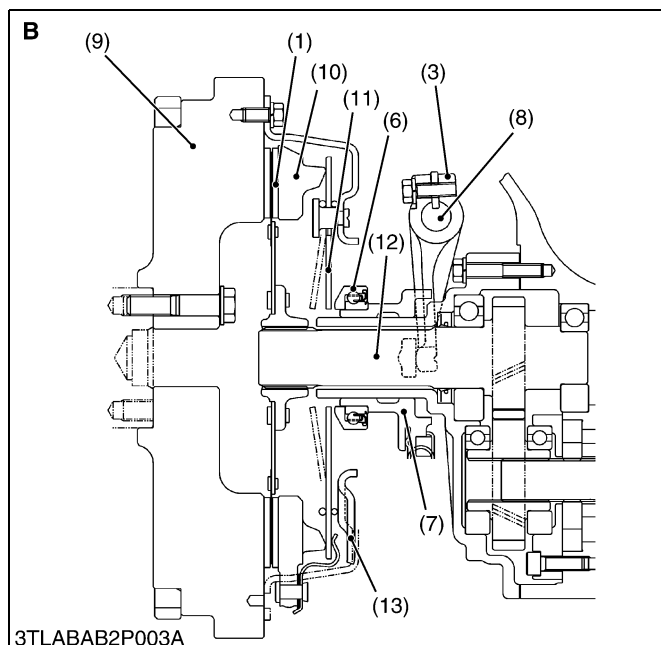
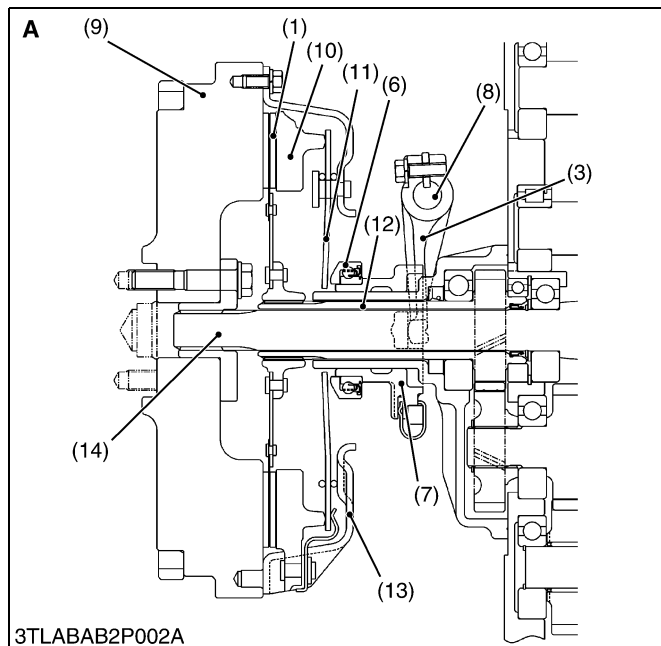

# SERVICING

## CONTENTS

1. TROUBLESHOOTING .....	2-S1
2. SERVICING SPECIFICATIONS .....	2-S2
3. TIGHTENING TORQUES .....	2-S3
4. CHECKING, DISASSEMBLING AND SERVICING.....	2-S4
[1] CHECKING AND ADJUSTING .....	2-S4
[2] DISASSEMBLING AND ASSEMBLING.....	2-S5
(1) Separating Clutch Housing and Engine .....	2-S5
(2) Removing Clutch Assembly .....	2-S14
[3] SERVICING .....	2-S15

# 1. TROUBLESHOOTING

Symptom	Probable Cause	Solution	Reference Page
<b>Clutch Drags</b>	<ul style="list-style-type: none"> <li>Clutch pedal free play excessive</li> <li>Dust on clutch disc generated from clutch disc facing</li> <li>Release fork broken</li> <li>Clutch disc or pressure plate warped</li> <li>Wire ring of the pressure plate worn or broken</li> </ul>	Adjust Remove rust  Replace Replace Replace (Pressure Plate assembly)	2-S4 –  2-S15 2-S14 2-S14
<b>Clutch Slips</b>	<ul style="list-style-type: none"> <li>Clutch pedal free play too small</li> <li>Clutch disc excessively worn</li> <li>Grease or oil on clutch disc facing</li> <li>Clutch disc or pressure plate warped</li> <li>Diaphragm spring weaken or broken</li> <li>Wiring of the pressure plate worn or broken</li> </ul>	Adjust Replace Replace Replace Replace Replace (Pressure Plate assembly)	2-S4 2-S14 2-S14 2-S14 2-S14 2-S14
<b>Chattering</b>	<ul style="list-style-type: none"> <li>Grease or oil on clutch disc facing</li> <li>Clutch disc or pressure plate warped</li> <li>Clutch disc boss spline worn or rusted</li> <li>Gear shaft bent</li> <li>Pressure plate or flywheel face cracked or scored</li> <li>Clutch disc boss spline and gear shaft spline worn</li> <li>Diaphragm spring strength uneven or diaphragm spring broken</li> </ul>	Replace Replace Replace or remove rust Replace  Replace  Replace  Replace	2-S14 2-S14 2-S14  3-S27, S62, S100 2-S14, 1-S41 2-S14, 3-S27, S62, S100 2-S14
<b>Rattle During Running</b>	<ul style="list-style-type: none"> <li>Clutch disc boss spline worn</li> <li>Thrust ball bearing worn or sticking</li> </ul>	Replace Replace	2-S14 2-S15
<b>Clutch Squeaks</b>	<ul style="list-style-type: none"> <li>Thrust ball bearing sticking or dry</li> <li>Clutch disc excessively worn</li> </ul>	Replace or lubricate Replace	2-S15 2-S14
<b>Vibration</b>	<ul style="list-style-type: none"> <li>Gear shaft bent</li> <li>Clutch disc rivet worn or broken</li> <li>Clutch parts broken</li> </ul>	Replace  Replace Replace	3-S26, S62, S99 2-S14 2-S14

W1014322

## 2. SERVICING SPECIFICATIONS

Item		Factory Specification	Allowable Limit
Clutch Pedal	Free play	20 to 30 mm 0.78 to 1.18 in.	–
Clutch Stopper Bolt	Height	18 to 22 mm 0.70 to 0.87 in.	–
Clutch Disc	Disc Surface to Rivet Top (Depth)	–	0.3 mm 0.012 in.
Clutch Disc Boss to Gear Shaft	Backlash (Displacement Around Disc Edge)	–	2.0 mm 0.079 in.
Pressure Plate	Flatness	–	0.2 mm 0.008 in.
Diaphragm Spring	Mutual Difference	–	0.5 mm 0.020 in.

W1013874

### 3. TIGHTENING TORQUES

Tightening torques of screws, bolts and nuts on the table below are especially specified.  
(For general use screws, bolts and nuts : See page G-10.)

Item	N·m	kgf·m	ft-lbs
Lower frame mounting screw	260 to 304	26.5 to 31.0	192 to 224
ROPS lower connector mounting screw	103 to 118	10.5 to 12.0	75.9 to 86.8
ROPS plate mounting screw (M14 × 40)	138 to 147	14.0 to 15.0	102 to 108
(M14 × 30)	167 to 196	17.0 to 20.0	123 to 145
Step mounting bolt and nut	124 to 147	12.6 to 15.0	91.1 to 108
Floor seat mounting bolt and nut	196 to 225	20 to 23	145 to 166
Compressor mounting screw	24.5 to 29.4	2.5 to 3.0	18.1 to 21.7
Muffler mounting screw	31.4 to 37.2	3.2 to 3.8	23.1 to 27.5
Cabin mounting bolt and nut	124 to 147	12.6 to 15.0	91.1 to 108
Joint bolt for main delivery pipe 1	49 to 69	5.0 to 7.0	36.1 to 50.6
Joint bolt for PTO delivery pipe	34 to 39	3.5 to 4.0	25.3 to 28.9
Joint bolt for oil cooler pipe	34 to 39	3.5 to 4.0	25.3 to 28.9
Clutch mounting screw	23.5 to 27.5	2.4 to 2.8	17.4 to 20.3
Release fork setting screw	23.5 to 27.5	2.4 to 2.8	17.4 to 20.3
Engine and clutch housing mounting screw and nut	77.5 to 90.2	7.9 to 9.2	57.1 to 66.5
Engine and clutch housing mounting stud bolt	39.2 to 49.0	4.0 to 5.0	28.9 to 36.2

W1012736

## 4. CHECKING, DISASSEMBLING AND SERVICING

### [1] CHECKING AND ADJUSTING

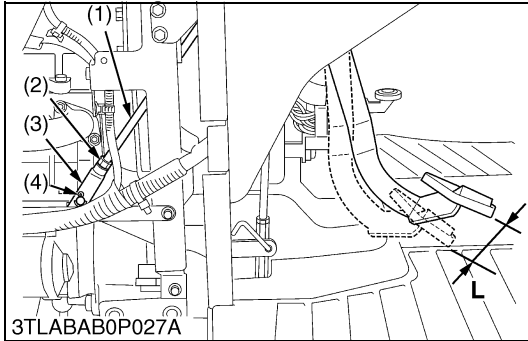

#### Clutch Pedal Free Travel

#### **⚠ CAUTION**

- When checking, park the tractor on flat ground, apply the parking brake, stop the engine and remove the key.

1. Slightly depress the clutch pedal and measure free travel "L" at top of clutch pedal.
2. If the measurement is not within the factory specifications, loosen the lock nut (2), remove the clevis pin (3) adjust the length of rod (1) within acceptable limits.
3. Retighten the lock nut (2) and split the cotter pin (4).

Clutch pedal free travel "L" on top of clutch pedal	Factory spec.	20 to 30 mm 0.78 to 1.18 in.
---	---------------	---------------------------------

- (1) Clutch Pedal Rod  
(2) Lock Nut  
(3) Clevis Pin

(4) Cotter Pin

**L : Free Travel**

W1018185



## [2] DISASSEMBLING AND ASSEMBLING

### (1) Separating Clutch Housing and Engine

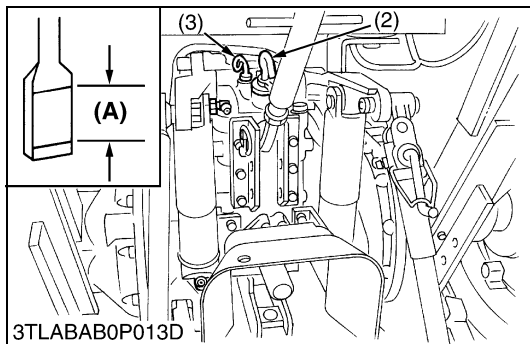
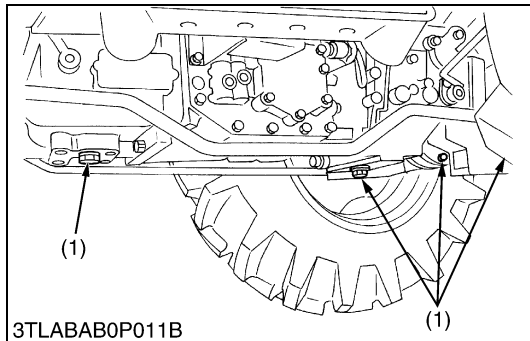

#### Draining the Transmission Fluid

1. Place oil pans underneath the transmission case.
2. Remove the drain plugs (1).
3. Drain the transmission fluid.
4. Reinstall the drain plugs (1).

#### (When refilling)

- Fill up from filling port after removing the filling plug (2) until reaching the upper notch on the dipstick (3).
- After running the engine for few minutes, stop it and check the oil level again, add the fluid to prescribed level if it is not correct level.

Transmission fluid capacity	L3130 L3430	42 L 11.1 U.S.gals 9.2 Imp.gals
	L3830 L4630	43 L 11.4 U.S.gals 9.5 Imp.gals
	L5030	45 L 11.9 U.S.gals 9.9 Imp.gals

#### ■ IMPORTANT

- Use only KUBOTA SUPER UDT fluid. Use of other oils may damage the transmission or hydraulic system. Refer to “LUBRICANTS, FUEL AND COOLANT”. (See page G-7, 8.)
- Do not mix different brands of fluid together.

- (1) Drain Plugs  
(2) Filling Plug  
(3) Dipstick

(A) Oil level is acceptable within this range.

W1018004

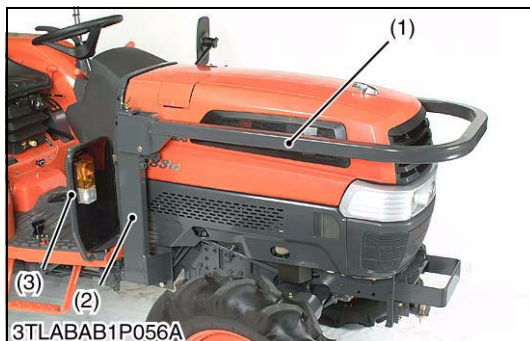

#### ROPS (Center ROPS Type)

1. Remove the upper frame (1) from ROPS lower frame (2).
2. Disconnect the light connectors.
3. Remove the shields (3).
4. Remove the lower frames (2).

#### (When reassembling)

#### ■ NOTE

- Do not firmly tighten all screws until most components are attached.

Tightening torque	Lower frame mounting screw	260 to 304 N·m 26.5 to 31.0 kgf·m 192 to 224 ft·lbs
-------------------	----------------------------	---

- (1) Upper Frame  
(2) Lower Frame

(3) Shield

W1015588



**Battery, Front Grill, Skirt and Bonnet**

1. Open the bonnet and disconnect the battery negative cable.
2. Disconnect the head light connector and remove the front grill (4).
3. Remove the left and right side skirts (3).
4. Disconnect window washer hoses (2). (Cabin model only.)
5. Remove the bonnet (1).

■ **NOTE**

- **When disconnecting the battery cords, disconnect the negative cord first, when connecting, positive cord first.**

- |                        |                 |
|------------------------|-----------------|
| (1) Bonnet             | (3) Skirt       |
| (2) Window Washer Hose | (4) Front Grill |

W1018348

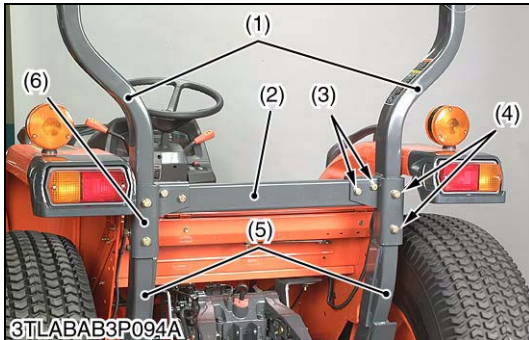

**ROPS**

1. Remove the lower connector (2).
2. Remove the plate mounting screws (4), (8).
3. Remove the upper frame (1) from ROPS lower frame (5).

**(When reassembling)**

■ **NOTE**

- **Do not firmly tighten all screws until most components are attached.**

Tightening torque	Lower connector mounting screw (3)	103 to 118 N-m 10.5 to 12.0 kgf-m 75.9 to 86.8 ft-lbs
	Plate mounting screw (4)	138 to 147 N-m 14.0 to 15.0 kgf-m 102 to 108 ft-lbs
	Plate mounting screw (8)	167 to 196 N-m 17.0 to 20.0 kgf-m 123 to 145 ft-lbs

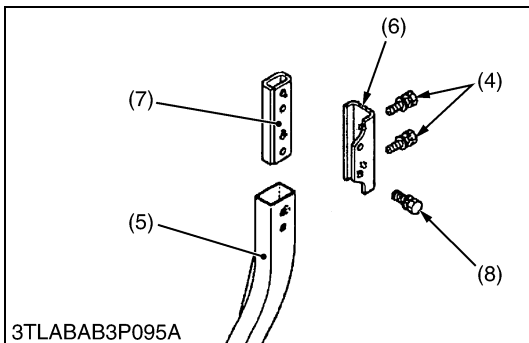

**(Reference)**

Tightening torque	Fulcrum bolt and nut (9)	118 to 137 N-m 12.0 to 14.0 kgf-m 86.8 to 102 ft-lbs
-------------------	--------------------------	--

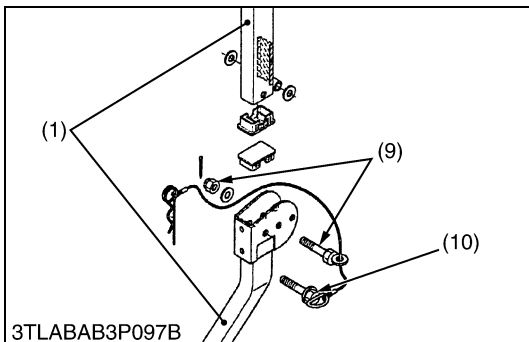

- |                      |                          |
|----------------------|--------------------------|
| (1) Upper Frame      | (6) Plate                |
| (2) Lower Connector  | (7) Connector            |
| (3) Screw (M12 × 65) | (8) Screw (M14 × 30)     |
| (4) Screw (M14 × 40) | (9) Fulcrum Bolt and Nut |
| (5) Lower Frame      | (10) Lock Bolt           |

W1015970

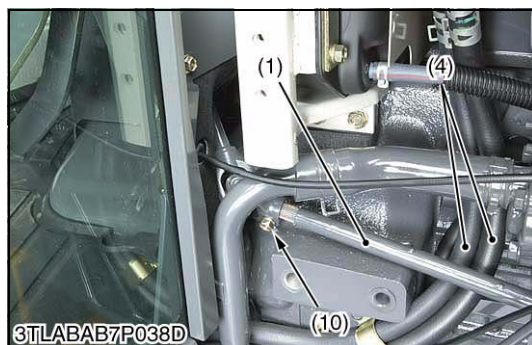
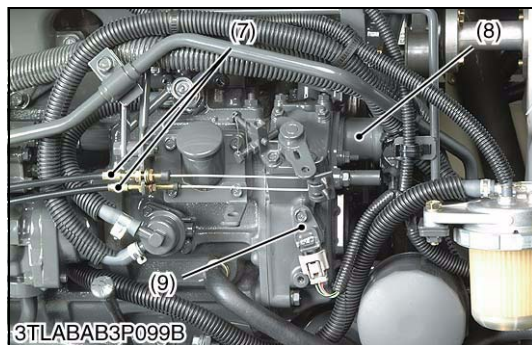
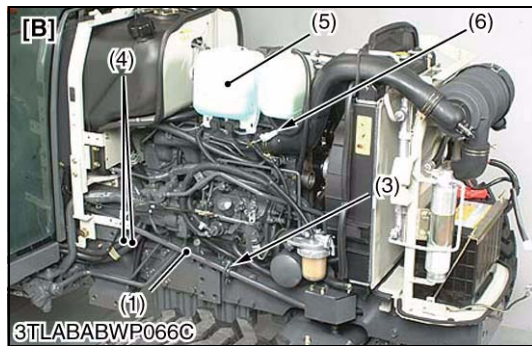
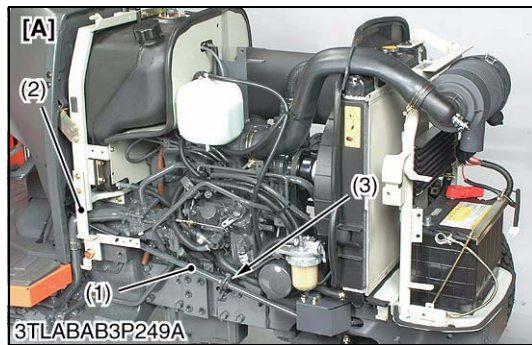

### Steering Joint, Heater Hoses and Electric Wiring

1. Remove the tank frame support (2).
2. Remove the universal joint bolt (10) and steering joint support (3), and then remove the steering joint (2).
3. Disconnect the hand accelerator wire and foot accelerator wire (7). (A feet accelerator is not equipped in HST model.)
4. Disconnect the wiring connectors for engine stop solenoid (8), engine tachometer sensor (9) and glow plug.
5. Disconnect the heater hoses (4), and then reconnect their hoses to make loop. (Cabin model only.)

#### ■ NOTE

- **Put a mark to the each heater hose before disconnecting.**
- 6. Disconnect the wiring connector for window washer tank (5) and compressor **1P** connector (6). (Cabin model only.)
- 7. Disconnect the brake pedal rod.

#### (When reassembling)

- When accelerator wire is installed, adjust the wiring length as hit both the idling speed adjusting bolt and the maximum speed adjusting bolt by lever within the stroke of the accelerator lever.
- Set the steering joint (1) by the joint support (3) so that the steering wheel is turned lightly.

- |                            |                              |
|----------------------------|------------------------------|
| (1) Steering Joint         | (7) Accelerator Wire         |
| (2) Tank Frame Support     | (8) Engine Stop Solenoid     |
| (3) Steering Joint Support | (9) Engine Tachometer Sensor |
| (4) Heater Hose            | (10) Universal Joint Bolt    |
| (5) Window Washer Tank     |                              |
| (6) <b>1P</b> Connector    |                              |

**[A] ROPS Model**  
**[B] Cabin Model**

W1018825



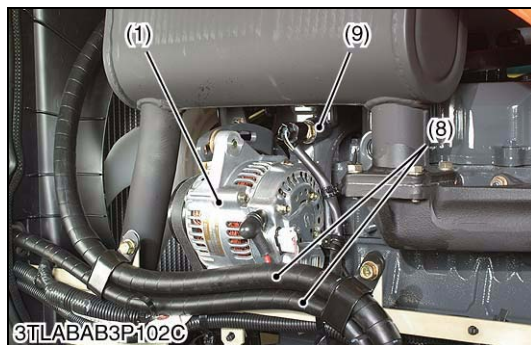
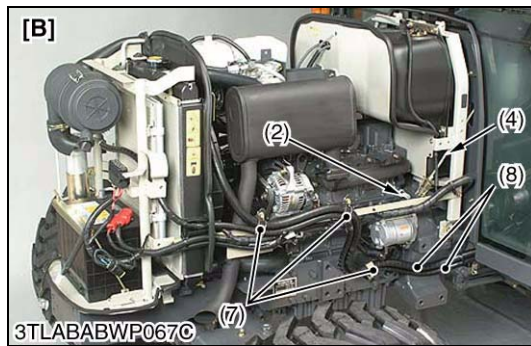
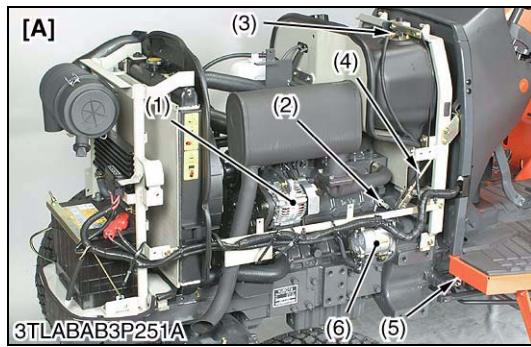

### Clutch Rod, Brake Pedal Rod and Electric Wiring

1. Disconnect the brake pedal rod (5) and clutch rod (4).
2. Disconnect the wiring connectors for alternator (1), coolant temperature sensor (9), oil pressure switch (2), fuel unit (3), starter motor (6) and battery.
3. Remove the clamps and ground earth of wiring harness and collect wiring harness to the step or cabin.
4. Remove the clamps (7) of A/C hoses (8). (Cabin A/C model only.)

### (When reassembling)

- Be sure to check and adjust the clutch and brake pedal free travel. (See page G-18, 24.)

- |                         |                                |
|-------------------------|--------------------------------|
| (1) Alternator          | (7) Clamps                     |
| (2) Oil Pressure Switch | (8) A/C Hoses                  |
| (3) Fuel Unit           | (9) Coolant Temperature Sensor |
| (4) Clutch Rod          |                                |
| (5) Brake Pedal Rod     |                                |
| (6) Starter Motor       |                                |

**[A] ROPS Model**

**[B] Cabin Model**

W1019114

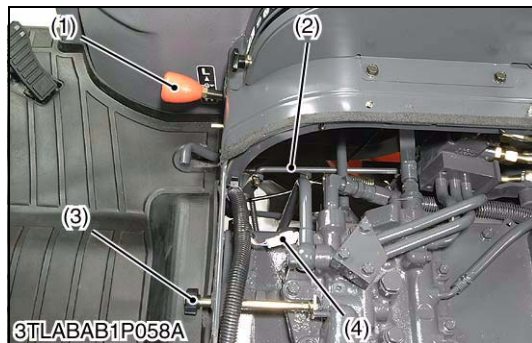
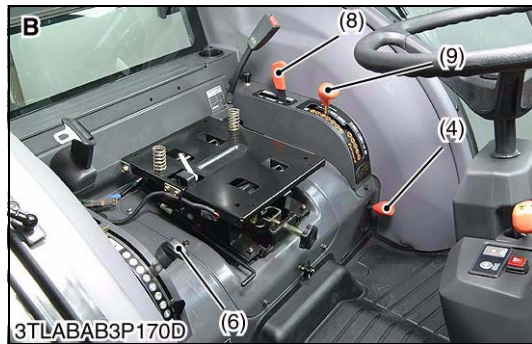
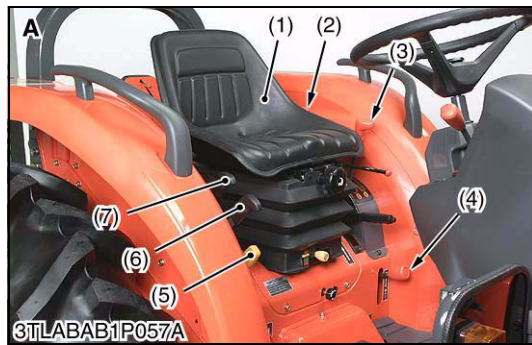

### **Seat, Seat Bracket and Lever Grips**

1. Remove the seat (1) with seat bracket.
2. Remove the front wheel drive lever (9).

#### **(Manual Transmission Model)**

3. Remove the lever grip for position control lever (6), draft control lever (7), range gear shift lever (2), creep shift lever (8), main shift lever (3) and ground PTO lever (5) (if equipped).

#### **(GST Model)**

3. Remove the lever grip for position control lever (6), draft control lever (7), GST lever (9), creep shift lever (8).

#### **(HST Model)**

3. Remove the lever grip for position control lever (6), range gear shift lever (2) and cruise control lever (10).

- |                             |                           |
|-----------------------------|---------------------------|
| (1) Seat                    | (8) Creep Shift Lever     |
| (2) Range Gear Shift Lever  | (9) GST Lever             |
| (3) Main Gear Shift Lever   | (10) Cruise Control Lever |
| (4) Front Wheel Drive Lever |                           |
| (5) Ground PTO Lever        |                           |
| (6) Position Control Lever  |                           |
| (7) Draft Control Lever     |                           |

**A : Manual Transmission Model**

**B : GST Model**

**C : HST Model**

W1016574

### **Differential Lock Rod, Lowering Speed Adjusting Knob and PTO Speed Change Lever (if equipped)**

1. Disconnect the differential lock rod (2).

#### **(Reference)**

- As for location of differential lock rod (2), it is at right side for manual transmission and GST model, and left side for HST model.
2. Remove the lowering speed adjusting knob (3).
  3. Remove the PTO speed change lever (1) (if equipped).
  4. Disconnect the PTO speed sensor (4) (if equipped).

- |                            |                                   |
|----------------------------|-----------------------------------|
| (1) PTO Speed Change Lever | (3) Lowering Speed Adjusting Knob |
| (2) Differential Lock Rod  | (4) PTO Speed Sensor              |

W1016961



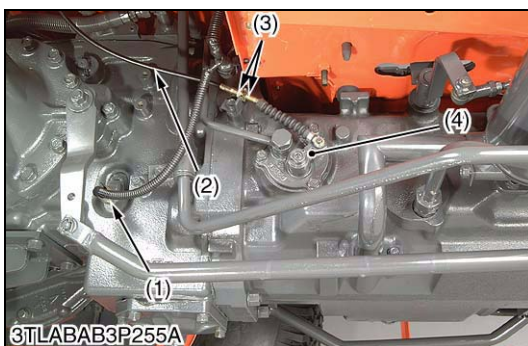
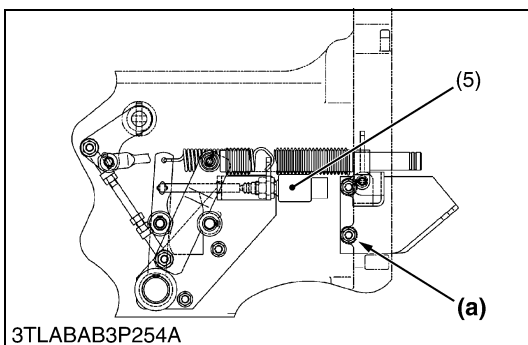
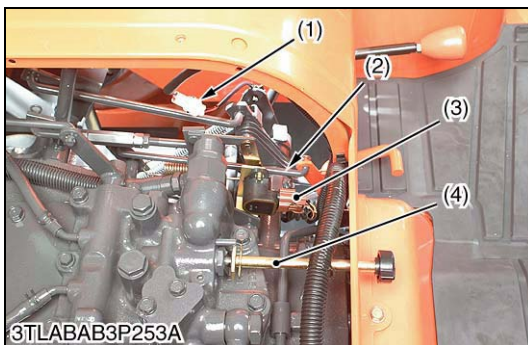
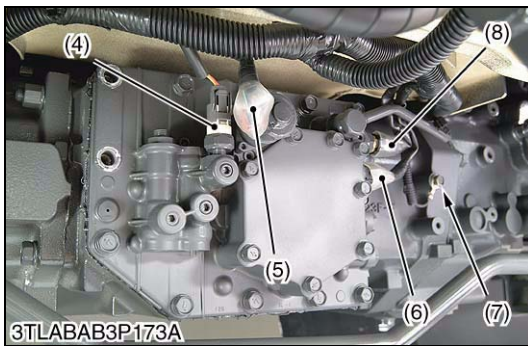
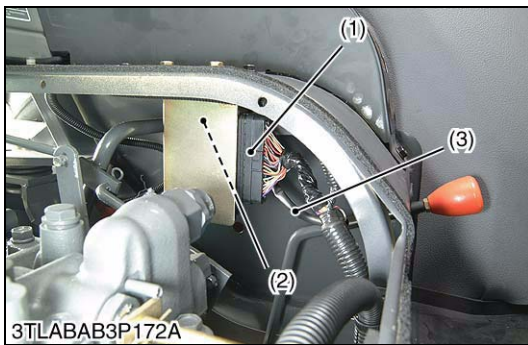

### Electric Connector for GST

1. Disconnect the ECU connector (1).
2. Disconnect the GST lever sensor connector (2).
3. Remove the GST valve cover.
4. Disconnect the pressure switch connector (4), proportional reducing valve connector (5), solenoid valve connector (6), oil temperature sensor connector (8) and ground cables (7).

#### (Reference)

- The ground cable (7) is at position where the manual transmission model is the same.

- |  |   |
|--|---|
| (1) ECU Connector                      | (5) Proportional Reducing Valve Connector |
| (2) GST Lever Sensor Connector         | (6) Solenoid Valve Connector              |
| (3) Wiring Harness of GST Lever Sensor | (7) Ground Cable                          |
| (4) Pressure Switch Connector          | (8) Oil Temperature Sensor Connector      |

W1019732

### Electric Connector for HST

1. Remove the lowering speed adjusting knob (4).
2. Disconnect the differential lock rod (2).
3. Disconnect the range gear shift lever sensor connector (3).
4. Disconnect the cruise switch connector (1).
5. Disconnect the HST pedal neutral switch connector (5).
6. Disconnect the ground earth (a).

- |   |  |
|---|--|
| (1) Cruise Switch Connector                 | (4) Lowering Speed Adjusting Knob      |
| (2) Differential Lock Pedal                 | (5) HST Pedal Neutral Switch Connector |
| (3) Range Gear Shift Lever Sensor Connector | (a) Ground earth is connected here     |

W1019896

### PTO Shift Wire and Electric Connector

1. Disconnect the PTO shift wire (2) at the PTO clutch valve lever (4).
2. Disconnect the traveling speed sensor connector (1).

#### (When reassembling)

- When connecting the PTO shift wire (2) to the lever (4), be sure to adjust the length of wire as follows.

1. Set the PTO shift lever to **OFF (Neutral)** position.
2. Loosen the lock nut (3) of wire, and connect wire to the clutch valve lever (4), and then place the wire to the hook.
3. Tighten the lock nut (3) clockwise (pull the wire), and lock the nut just before the lever moves.

- |                                      |                            |
|--------------------------------------|----------------------------|
| (1) Traveling Speed Sensor Connector | (3) Lock Nut               |
| (2) PTO Shift Wire                   | (4) PTO Clutch Valve Lever |

W1020066

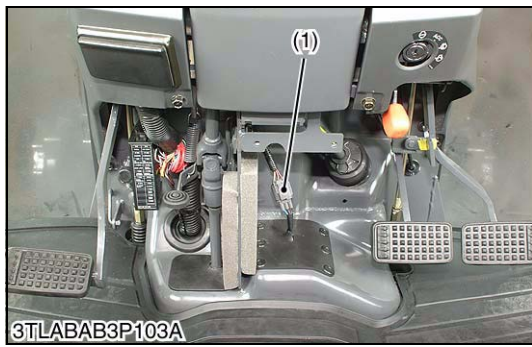

**Shuttle Switch Connector (Manual and GST Model)**

1. Remove the panel cover and steering post cover.
2. Disconnect the shuttle switch connector (1).

(1) Shuttle Switch Connector

W1020239

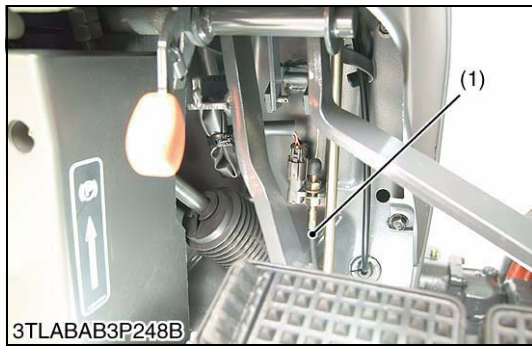

**Cruise Control Release Wire (HST Model)**

1. Disconnect the cruise control release wire (1).
- (When reassembling)**

- Be sure to adjust the cruise control release wire (1). (See page 3-S92.)

(1) Cruise Control Release Wire

W1020333

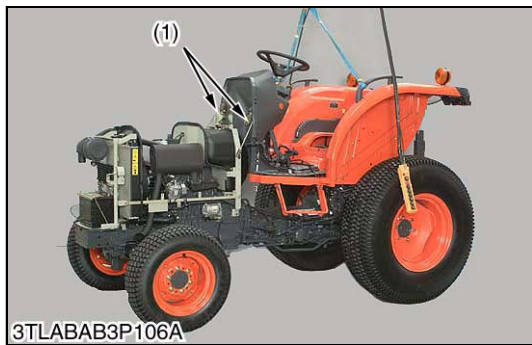

**Step and Floor Seat (ROPS Model)**

1. Disconnect the panel frame connector (1) from fuel tank frame.
2. Remove the step and floor seat mounting bolt and nut.
3. Dismount the step, fender, floor seat and panel frame as a unit after checking whether there is forgetting to disconnect wiring.

**(When reassembling)**

- Be sure to set the washers and rubber plates of the floor seat and step mounting bolt at an original positions as shown in figure.
- Before mounting the floor seat and step, be sure to set both the shuttle lever rod and the shuttle arm to the neutral position, and then connect the shuttle lever rod securely. (Manual and GST model)

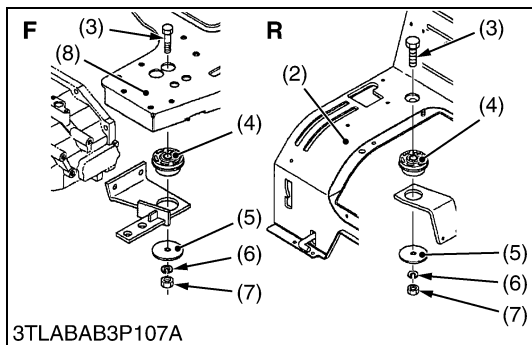

Tightening torque	Step mounting bolt and nut	124 to 147 N·m 12.6 to 15.0 kgf·m 91.1 to 108 ft·lbs
	Floor seat mounting bolt and nut	196 to 225 N·m 20 to 23 kgf·m 145 to 166 ft·lbs

- (1) Panel Frame Connector
- (2) Floor Seat
- (3) Bolt
- (4) Rubber Plate
- (5) Washer
- (6) Spring Washer

- (7) Nut
- (8) Step

**F : Front Side**  
**R : Rear Side**

W1020698



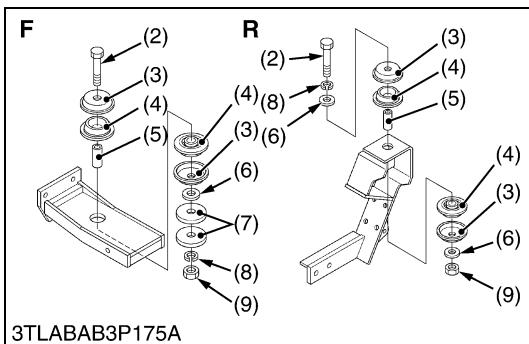
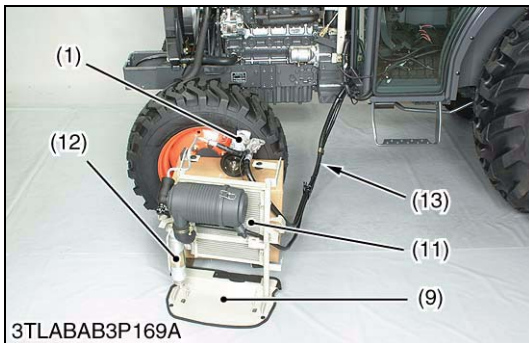
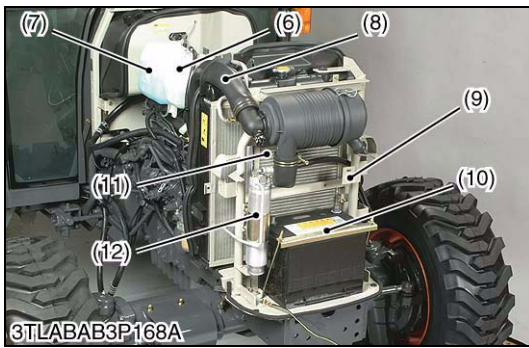
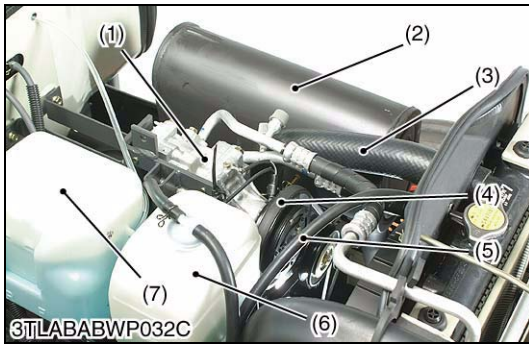

**Air Conditioner Parts (Cabin A/C Model)**

1. Remove the muffler (2).
2. Remove the air conditioner belt (4) and remove the compressor (1) mounting screw.
3. Remove the recovery tank (6) and window washer tank (7).
4. Disconnect the air cleaner hose (8).
5. Disconnect the recovery tank hose (5).
6. Disconnect the radiator upper hose (3).
7. Remove the oil cooler mounting screw. (HST model only)
8. Remove the battery (10).
9. Remove the battery stay mounting bolt.
10. Take out the compressor (1), condenser (11), receiver (12), hoses (13), battery stay (9) and etc. as a unit.

**(When reassembling)**

- After reassembling the compressor, be sure to adjust the air conditioner belt tension. (See page G-29.)

Tightening torque	Compressor mounting screw	24.5 to 29.4 N·m 2.5 to 3.0 kgf·m 18.1 to 21.7 ft·lbs
	Muffler mounting screw	31.4 to 37.2 N·m 3.2 to 3.8 kgf·m 23.1 to 27.5 ft·lbs

- |                          |                           |
|--------------------------|---------------------------|
| (1) Compressor           | (8) Air Cleaner Hose      |
| (2) Muffler              | (9) Battery Stay          |
| (3) Radiator Upper Hose  | (10) Battery              |
| (4) Air Conditioner Belt | (11) Condenser            |
| (5) Recovery Tank Hose   | (12) Receiver             |
| (6) Recovery Tank        | (13) Air Conditioner Hose |
| (7) Window Washer Tank   |                           |

W1020914

**Cabin Assembly**

1. Remove the outer roof of cabin.
2. Support the cabin with nylon straps (1) and hoists.
3. Loosen and remove the cabin mounting bolts (2) and nuts (9).
4. Dismounting the cabin from tractor body.

**NOTE**

- Lift the cabin while making sure it does not catch on anything.

**(When reassembling)**

- Be sure to install the washers and mount rubbers, etc. in their original positions.
- Before mounting the cabin, be sure to set both the shuttle lever rod and the shuttle arm to the neutral position, and then connect the shuttle lever rod securely. (GST model)

Tightening torque	Cabin mounting bolt and nut	124 to 147 N·m 12.6 to 15.0 kgf·m 91.1 to 108 ft·lbs
-------------------	-----------------------------	--

- |                        |                       |
|------------------------|-----------------------|
| (1) Nylon Straps       | (7) Washer            |
| (2) Bolt               | (8) Spring Washer     |
| (3) Plate              | (9) Nut               |
| (4) Mount Rubber       |                       |
| (5) Collar             | <b>F : Front Side</b> |
| (6) Plain Washer (M14) | <b>R : Rear Side</b>  |

W1021215



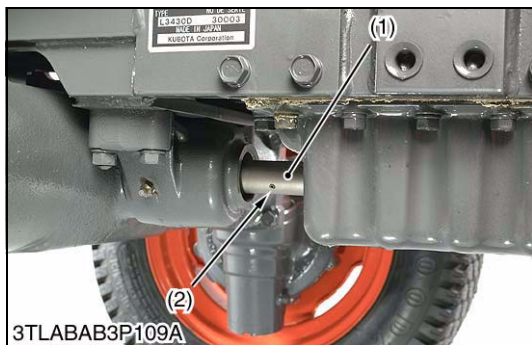
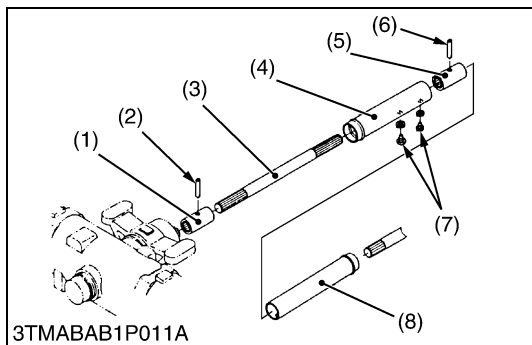
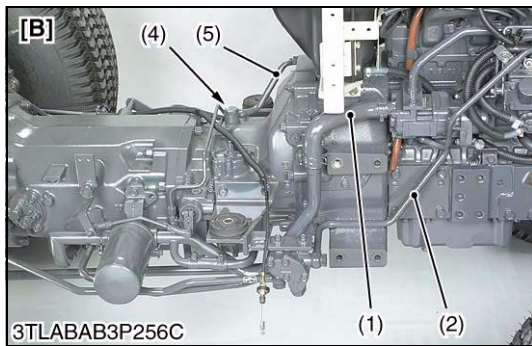
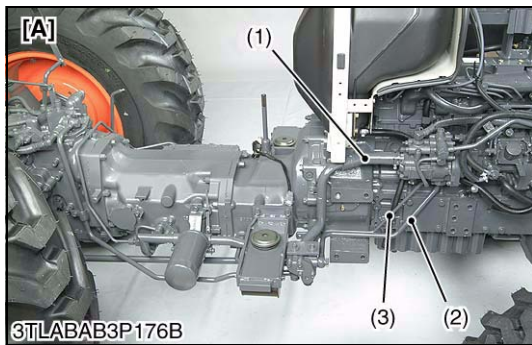

**Hydraulic Pipes**

1. Remove the main delivery pipe 1 (2).
2. Remove the PTO delivery pipe (3). (Manual and GST model)
3. Disconnect the suction hose (1) from hydraulic pump.
4. Remove the joint bolt (4) of oil cooler pipe (5). (HST model)

**(When reassembling)**

Tightening torque	Joint bolt for main delivery pipe 1 to front hydraulic block	49 to 69 N·m 5.0 to 7.0 kgf·m 36.1 to 50.6 ft-lbs
	Joint bolt for PTO delivery pipe	34 to 39 N·m 3.5 to 4.0 kgf·m 25.3 to 28.9 ft-lbs
	Joint bolt for oil cooler pipe	34 to 39 N·m 3.5 to 4.0 kgf·m 25.3 to 28.9 ft-lbs

- (1) Suction Hose
- (2) Main Delivery Pipe 1
- (3) PTO Delivery Pipe
- (4) Joint Bolt

- (5) Oil Cooler Pipe

**[A] Manual and GST Model**  
**[B] HST Model**

W1021456

**Propeller Shaft**

1. Slide the propeller shaft cover (4) and (8) after removing the screws (7).
2. Tap out the spring pins (2), (6) and slide the couplings (1), (5) and then remove the propeller shaft with covers (4), (8).

**(When reassembling)**

- Apply grease to the splines of propeller shaft 1 (3).

- (1) Coupling
- (2) Spring Pin
- (3) Propeller Shaft 1
- (4) Propeller Shaft Cover

- (5) Coupling
- (6) Spring Pin
- (7) Screws
- (8) Propeller Shaft Cover

W1021671



**Separating Engine and Clutch Housing**

1. Place the disassembling stand under the engine and clutch housing case.
2. Remove the fuel tank support mounting screws.
3. Remove the engine and clutch housing mounting screws and nuts.
4. Separate the engine and clutch housing while lifting up the tank frame.

**(When reassembling)**

- Apply grease to the spline of clutch shaft.
- Apply liquid gasket (Three Bond 1211 or equivalent) to joint face of the flywheel housing and clutch housing.

Tightening torque	Engine and clutch housing mounting screw and nut	77.5 to 90.2 N-m 7.9 to 9.2 kgf-m 57.1 to 66.5 ft-lbs
	Engine and clutch housing mounting stud bolt	39.2 to 49.0 N-m 4.0 to 5.0 kgf-m 28.9 to 36.2 ft-lbs

W1021830

**(2) Removing Clutch Assembly**



**Clutch Assembly**

1. Remove the clutch from the flywheel.

**(When reassembling)**

- Direct the shorter end of the clutch disc boss toward the flywheel.
- Apply molybdenum disulphide (Three Bond 1901 or equivalent) to the splines of clutch disc boss.
- Install the pressure plate, noting the position of straight pins.

**■ IMPORTANT**

- **Align the center of disc and flywheel by inserting the clutch center tool. (See page G-47.)**

**■ NOTE**

- **Do not allow grease and oil on the clutch disc facing.**

Tightening torque	Clutch mounting screws	23.5 to 27.5 N-m 2.4 to 2.8 kgf-m 17.5 to 20.3 ft-lbs
-------------------	------------------------	---

W1019957

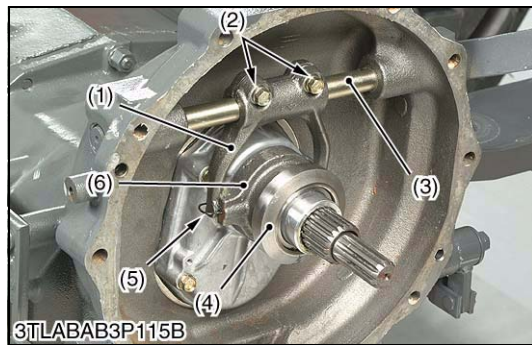

3TLABAB3P115B

### Release Holder and Clutch Lever

1. Draw out the clutch release hub (6) and the release bearing (4) as a unit.
2. Remove the release fork setting screws (2).
3. Draw out the clutch lever (3) to remove the release fork (1).

#### (When reassembling)

- Make sure the direction of the release fork (1) is correct.
- Inject grease to the release hub (6).
- Be sure to set the snap pins (5).

Tightening torque	Release fork setting screws	23.5 to 27.5 N·m 2.4 to 2.8 kgf·m 17.4 to 20.3 ft·lbs
-------------------	-----------------------------	---

- |                   |                     |
|-------------------|---------------------|
| (1) Release Fork  | (4) Release Bearing |
| (2) Setting Screw | (5) Snap Pin        |
| (3) Clutch Lever  | (6) Release Hub     |

W1015118

## [3] SERVICING

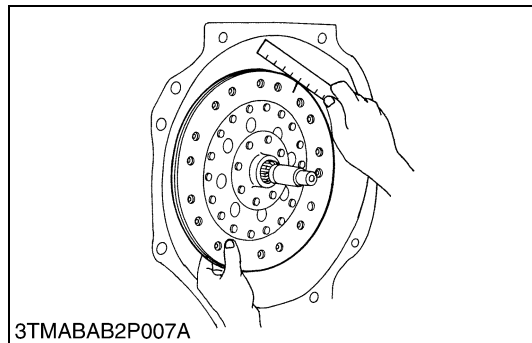

3TMABAB2P007A

### Backlash between Clutch Disc Boss and Gear Shaft

1. Mount the clutch disc to the gear shaft.
2. Hold the gear shaft so that it may not turn.
3. Rotate disc lightly and measure the displacement around the disc edge.
4. If the measurement exceeds the allowable limit, replace the disc.

Displacement around disc edge	Allowable limit	2.0 mm 0.079 in.
-------------------------------	-----------------	---------------------

W1016866

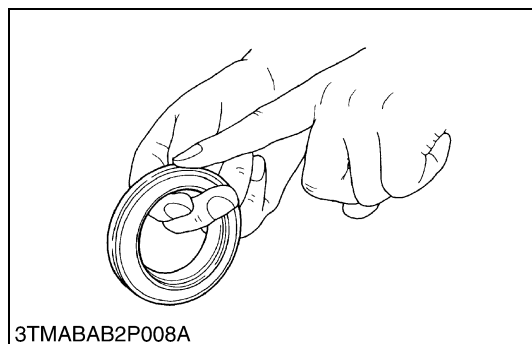

3TMABAB2P008A

### Thrust Ball Bearing

1. Remove the thrust ball bearing from release hub with a puller.
2. Check for abnormal wear on contact surface.
3. Hold bearing inner race and rotate outer race, while applying pressure to it.
4. If the bearing rotation is rough or noisy, replace the bearing.

#### ■ NOTE

- Do not depress outer race, while installing thrust ball bearing

W1017028

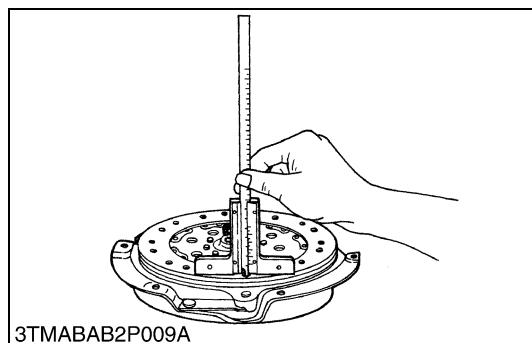

3TMABAB2P009A

### Clutch Disc Wear

1. Measure the depth from clutch disc surface to the top of rivet at least 10 points with a depth gauge.
2. If the depth is less than the allowable limit, replace the disc.
3. If oil is sticking to clutch disc, or disc surface is carbonized, replace the disc.  
In this case, inspect transmission gear shaft oil seal, engine rear oil seal and other points for oil leakage.

Disc surface to rivet top (Depth)	Allowable limit	0.3 mm 0.012 in.
-----------------------------------	-----------------	---------------------

W1017162

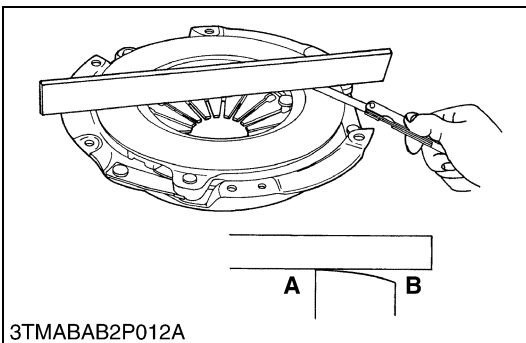
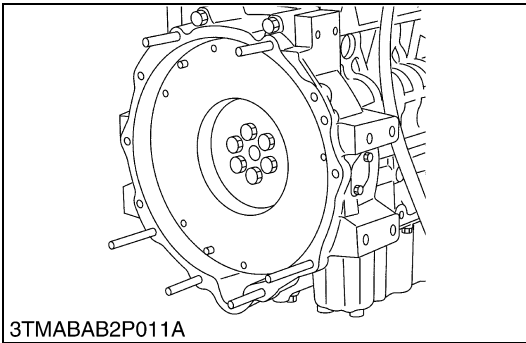
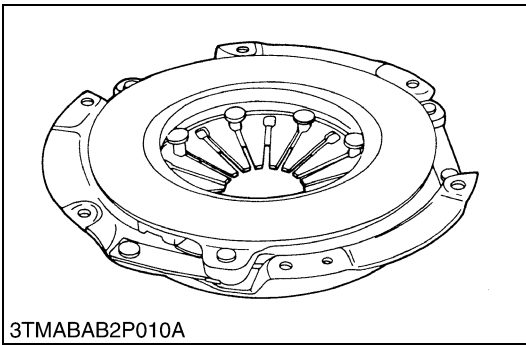

### Checking Pressure Plate Assembly and Flywheel

1. Wash the disassembling parts except clutch disc with a suitable cleaning solvent to remove dirt and grease before making inspection and adjustment.
2. Check friction surface of pressure plate and flywheel for scoring or roughness.
  - Slight roughness may be smoothed by using fine emery cloth.
  - If these parts have deep scores or grooves on their surface, they should be replaced.
3. Check the surface of the diaphragm spring for wear. If excessive wear is found, replace clutch cover assembly.
4. Inspect thrust rings (wire ring) for wear or damage. As these parts are invisible from outside, shake pressure plate assembly up and down to listen for chattering noise, or lightly hammer on rivets for a slightly cracked noise. Any of these noises indicates need of replace as a complete assembly.

Diaphragm spring mutual difference	Allowable limit	0.5 mm 0.020 in.
------------------------------------	-----------------	---------------------

W1017284

### Pressure Plate Flatness

1. Place a straight edge on the pressure plate and measure clearance with a feeler gauge at several points.
2. If the clearance exceeds the allowable limit, replace it.
3. When the pressure plate is worn around its outside and its inside surface only is in contact with the straight edge, replace even if the clearance is within the allowable limit.

Clearance between pressure plate and straight edge	Allowable limit	0.2 mm 0.008 in.
--	-----------------	---------------------

A : inside

B : Outside

W1017439

# **3 TRANSMISSION**



# MECHANISM

## CONTENTS

1. MANUAL TRANSMISSION MODEL .....	3-M1
[1] STRUCTURE .....	3-M1
[2] POWER TRAIN FOR TRAVELING GEAR.....	3-M3
(1) Main Gear Shift Section .....	3-M3
(2) Shuttle Shift Section.....	3-M3
(3) Range Gear Shift Section .....	3-M4
(4) Front Wheel Drive Section .....	3-M4
(5) Creep Gear Shift Section .....	3-M5
[3] SHIFT LINKAGE MECHANISM .....	3-M5
(1) Main Gear Shift Lever .....	3-M5
(2) Shuttle Shift Lever.....	3-M6
(3) Range Gear Shift Lever .....	3-M6
(4) Front Wheel Drive Lever .....	3-M6
(5) Creep Gear Shift Lever .....	3-M7
2. GLIDE SHIFT TRANSMISSION (GST) MODEL .....	3-M8
[1] STRUCTURE .....	3-M8
[2] CHARACTERISTIC AND SYSTEM OUTLINE.....	3-M9
[3] POWER TRAIN.....	3-M10
[4] ELECTRICAL CONTROL SYSTEM.....	3-M11
(1) Construction and Function of Components.....	3-M11
(2) Electrical Control.....	3-M14
[5] HYDRAULIC CONTROL SYSTEM.....	3-M15
(1) Hydraulic Circuit and System Outline .....	3-M15
(2) Construction and Function of Components.....	3-M17
[6] SHIFT LINKAGE MECHANISM .....	3-M24
3. HYDROSTATIC TRANSMISSION (HST) MODEL.....	3-M25
[1] STRUCTURE .....	3-M25
[2] POWER TRAIN.....	3-M26
(1) Hydrostatic Transmission (HST) .....	3-M26
(2) Range Gear Shift Section .....	3-M36
(3) Front Wheel Drive Section .....	3-M36
[3] SHIFT LINKAGE MECHANISM .....	3-M37
(1) Range Gear Shift Lever .....	3-M37
4. PTO SYSTEM .....	3-M38
[1] STRUCTURE .....	3-M38
[2] PTO CLUTCH .....	3-M39
(1) Shift Linkage .....	3-M39
(2) Oil Flow .....	3-M39
(3) Operation .....	3-M40
[3] GROUND PTO (IF EQUIPPED).....	3-M41
(1) Power Train.....	3-M41
(2) Shift Linkage .....	3-M41
[4] TWO STAGE PTO (IF EQUIPPED).....	3-M42
(1) Power Train.....	3-M42
(2) Shift Linkage .....	3-M42

# 1. MANUAL TRANSMISSION MODEL

## [1] STRUCTURE

### ■ Standard Type (with Creep Speed)

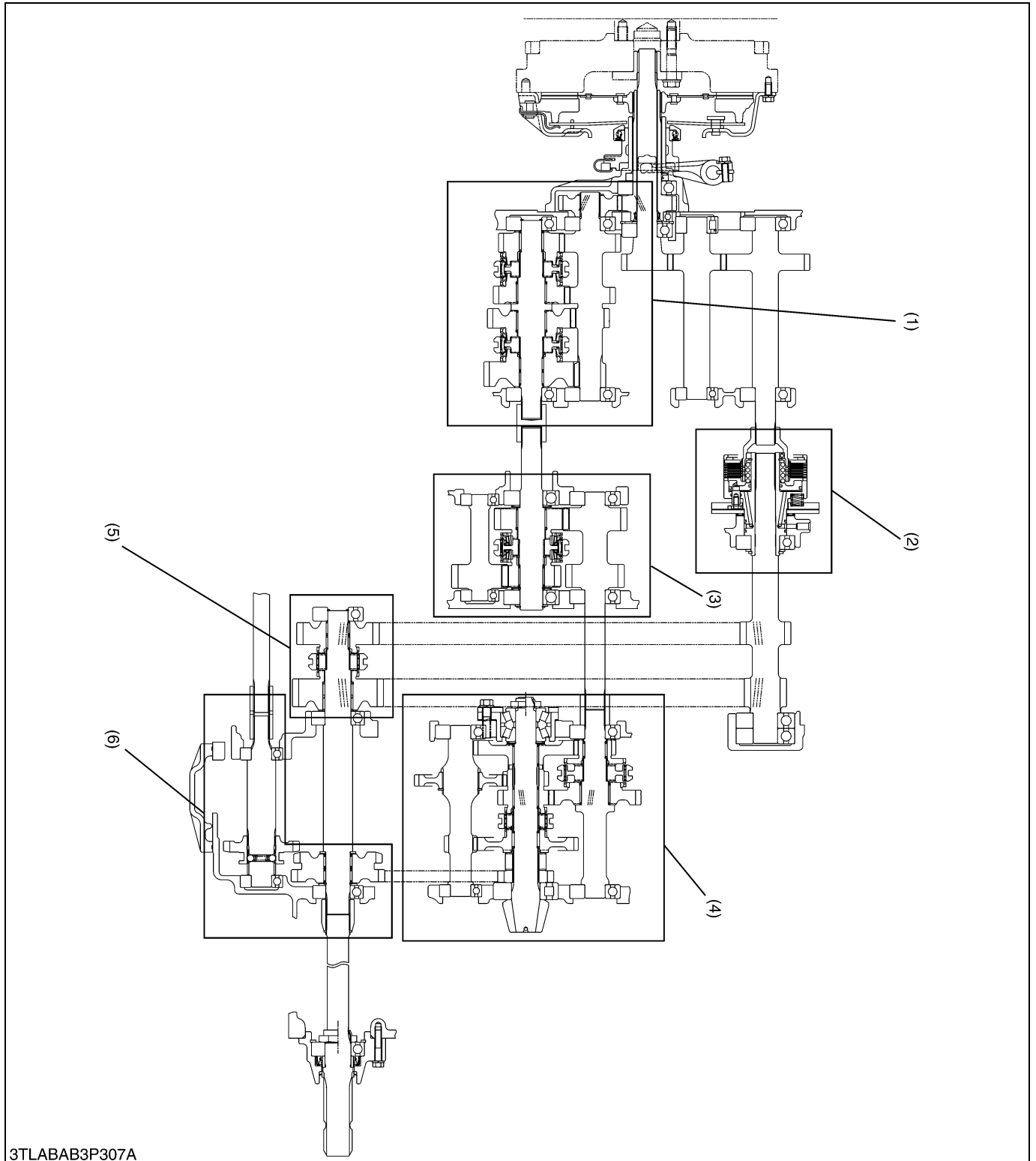

3TLBAB3P307A

(1) Main Gear Shift Section  
 (2) PTO Clutch Section  
 (3) Shuttle Shift Section

(4) Range Gear and Creep Gear  
 Shift Section

(5) PTO Gear Shift Section

(6) Front Wheel Drive Shift  
 Section



### ■ Ground PTO Type (without Creep Speed)

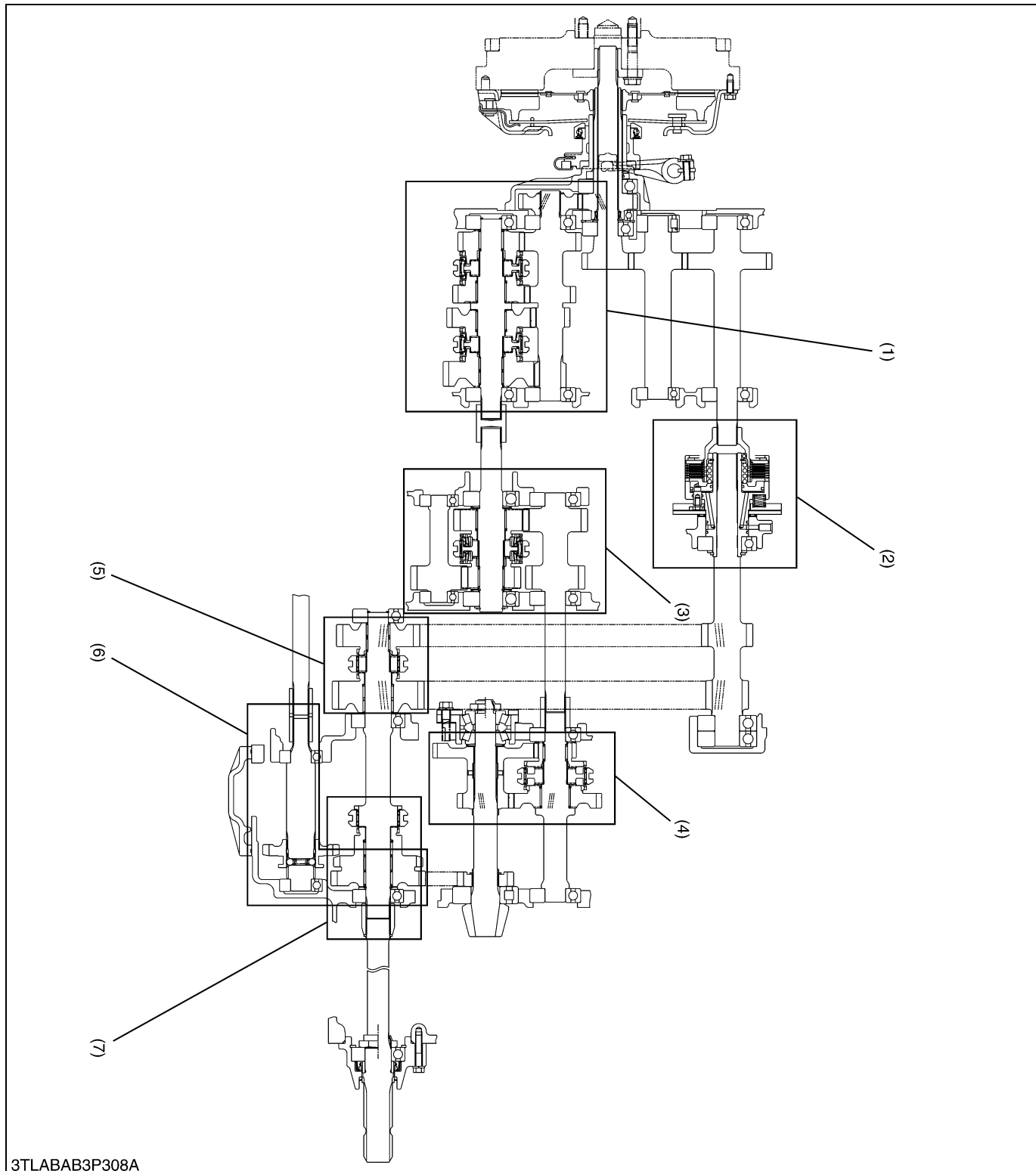

3TLABAB3P308A

(1) Main Gear Shift Section  
 (2) PTO Clutch Section  
 (3) Shuttle Shift Section

(4) Range Gear Shift Section  
 (5) PTO Gear Shift Section

(6) Front Wheel Drive Shift Section

(7) Ground PTO Gear Shift Section

## [2] POWER TRAIN FOR TRAVELING GEAR

The transmission consists of a series of gears and shafts as shown in previous page.

The traveling system consists of main gear shift section, shuttle shift section, range gear shift section and front wheel drive section.

### (1) Main Gear Shift Section

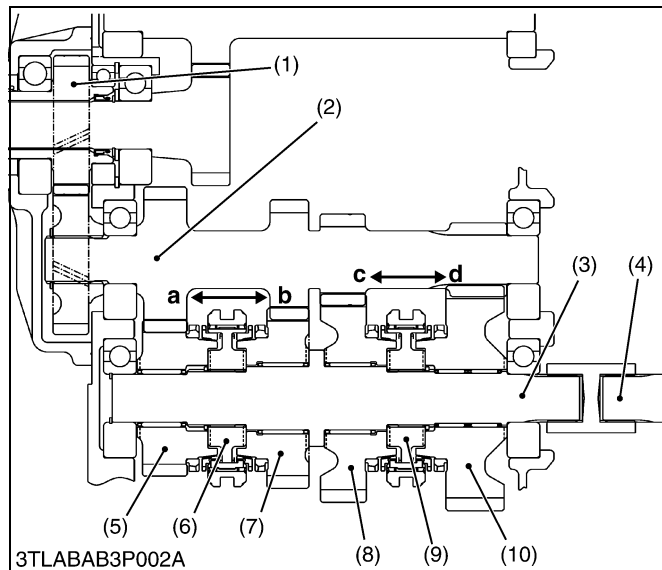

The main gear shift section is located in the clutch housing, and it uses a synchromesh.

Power which is transmitted from the engine to the gear shaft (1) via the clutch is changed in four ways by operating the main shift lever to shift the shifters, and transmits to the counter shaft (3).

- |                                     |                                     |
|-------------------------------------|-------------------------------------|
| (1) Gear Shaft (Input)              | (8) Gear for 2nd                    |
| (2) Main Shaft                      | (9) Synchromesh Gears (1st and 2nd) |
| (3) Counter Shaft                   | (10) Gear for 1st                   |
| (4) Shuttle Shaft                   | <b>a : 4th Speed</b>                |
| (5) Gear for 4th                    | <b>b : 3rd Speed</b>                |
| (6) Synchromesh Gears (3rd and 4th) | <b>c : 2nd Speed</b>                |
| (7) Gear for 3rd                    | <b>d : 1st Speed</b>                |

W1012742

### (2) Shuttle Shift Section

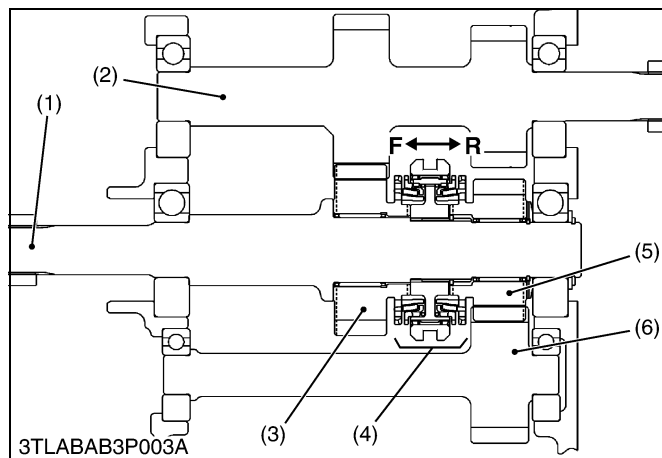

The shuttle shift section is located in the mid case, and it uses a double cone type synchromesh. It allows the operator to change forward and reverse for each speed from the first to eight with single shift lever.

The double cone type synchromesh is characterized by its light operating force and durability because it engages with the gear in reverse rotation when the speed is changed from forward to reverse position or vice versa.

Two synchronizing rings (7), (9) are installed on one side, and the center ring (8) is provided between the synchronizing rings. This construction doubles the ground contact area of the synchronizer rings (7), (9) and improves the durability as compared with the ordinary key type synchromesh.

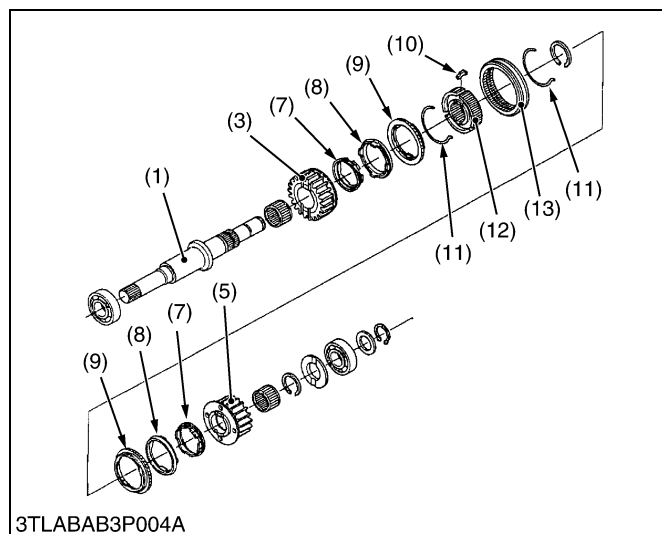

- |  |                             |
|--|-----------------------------|
| (1) Shuttle Shaft (Connected to Counter Shaft)         | (7) Outer Synchronizer Ring |
| (2) Shuttle Gear Shaft (Connected to Range Gear Shaft) | (8) Center Ring             |
| (3) Gear for Forward                                   | (9) Inner Synchronizer Ring |
| (4) Double Cone Type Synchromesh                       | (10) Synchronizer Key       |
| (5) Gear for Reverse                                   | (11) Synchronizer Spring    |
| (6) Reverse Gear Shaft                                 | (12) Hub                    |
|  | (13) Shifter                |
- F : Forward**  
**R : Reverse**

W1012964

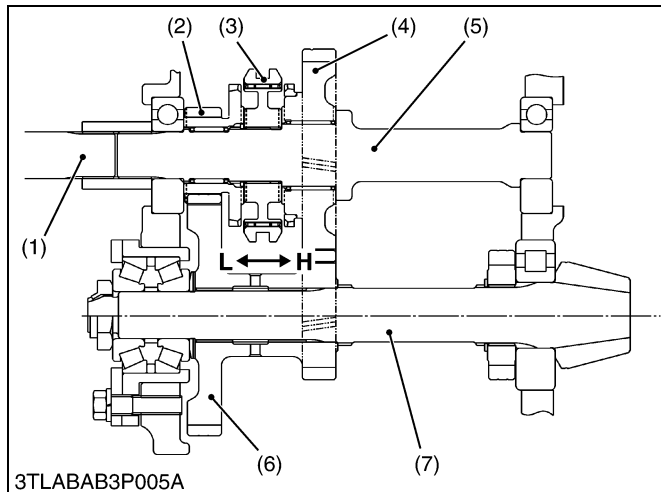
**(3) Range Gear Shift Section**

The range gear shift section is located in the differential gear case, and it uses constant mesh.

- |                        |                         |
|------------------------|-------------------------|
| (1) Shuttle Gear Shaft | (6) Counter Gear        |
| (2) Gear for Low       | (7) Spiral Bevel Pinion |
| (3) Shifter            |                         |
| (4) Gear for High      |                         |
| (5) Range Gear Shaft   |                         |
- L : Low Speed**  
**H : High Speed**

W1013209

3TLABAB3P005A

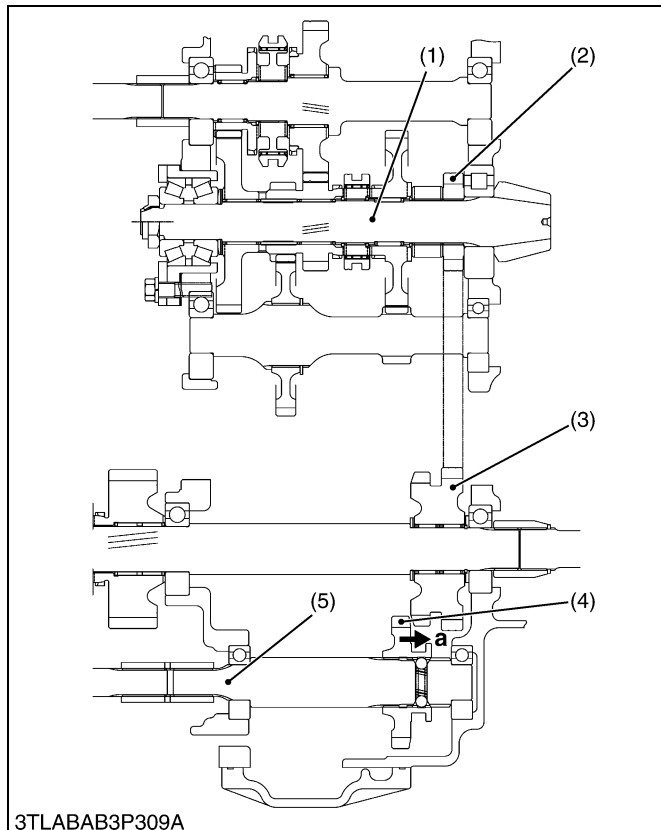
**(4) Front Wheel Drive Section**

Front wheel drive shift section is located in the differential gear case. 2 wheel drive or 4 wheel drive is selected by operating the front wheel drive lever to shift the shifter gear (4).

- |                            |   |
|----------------------------|---|
| (1) Spiral Bevel Pinion    | (5) Front Wheel Drive Shaft<br>(Connected to Propeller Shaft) |
| (2) Gear                   |   |
| (3) Front Wheel Drive Gear |   |
| (4) Shifter Gear           | <b>a : 4 Wheel Drive Position</b>                             |

W1013518

3TLABAB3P309A

### (5) Creep Gear Shift Section

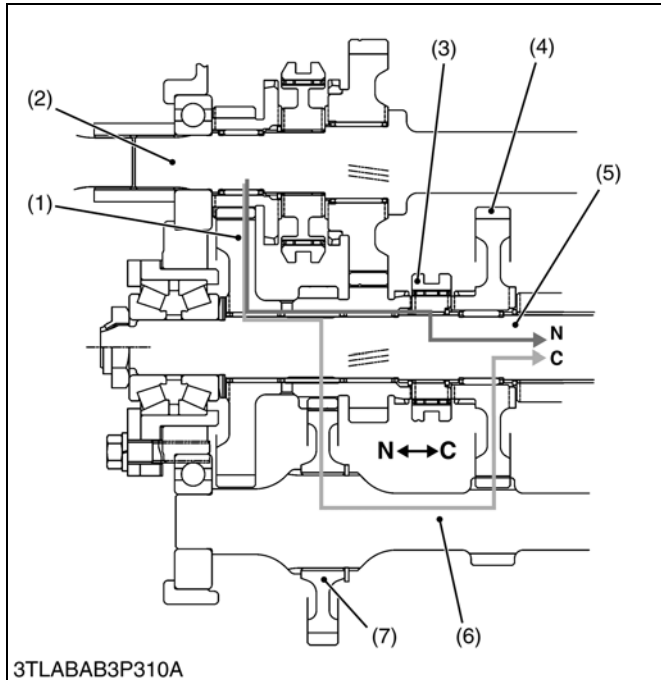

The creep speed section is located under the **N-C** range gear shift section to reduce a travelling speed. It is shifted by the creep shift lever to shift the shifter (3).

The power train of creep speed is as shown in figure.

- (1) Creep Output Gear
- (2) Range Gear Shaft
- (3) Shifter
- (4) Low Speed Counter Gear
- (5) Spiral Bevel Pinion Shaft
- (6) Creep Gear Shaft
- (7) Creep Gear

**N : Normal Speed**  
**C : Creep Speed**

W1021456

### [3] SHIFT LINKAGE MECHANISM

#### (1) Main Gear Shift Lever

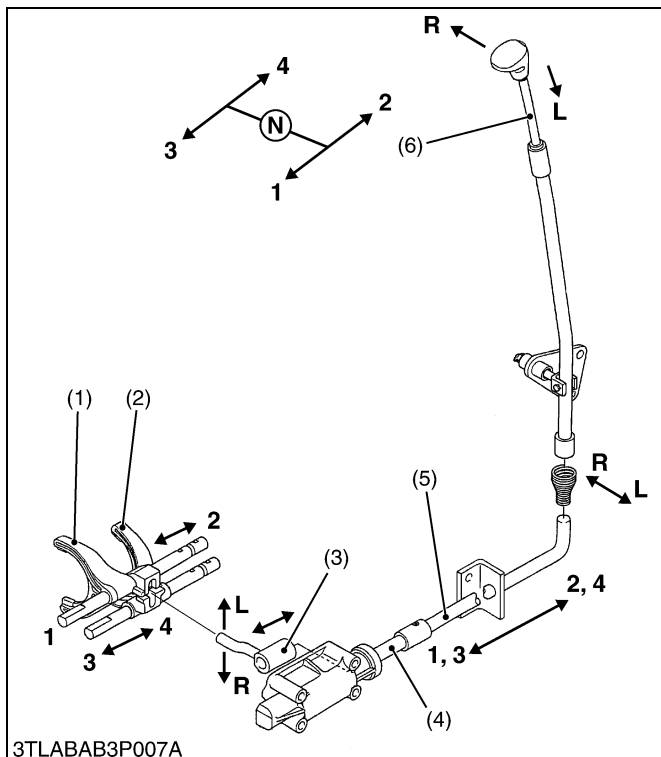

The links are connected from the shift lever (6) to the shift forks (1), (2) as shown in the figure. Each speed from the 1st to 4th can be changed by a single shift lever (6).

When the shift lever (6) is moved to the left, the shift arm (3) is engaged with the 1-2 shift fork (1), allowing the operator to change the 1st or the 2nd speed.

When the shift lever (6) is moved to the right, the shift arm (3) is engaged with the 3-4 shift fork (2), allowing the operator to change the 3rd or the 4th speed.

- (1) 1-2 Shift Fork
- (2) 3-4 Shift Fork
- (3) Shift Arm
- (4) Shift Rod 1
- (5) Shift Rod 2
- (6) Main Gear Shift Lever

**R : Right Movement**  
**L : Left Movement**  
**1 : 1st Shift**  
**2 : 2nd Shift**  
**3 : 3rd Shift**  
**4 : 4th Shift**

W1013619

## (2) Shuttle Shift Lever

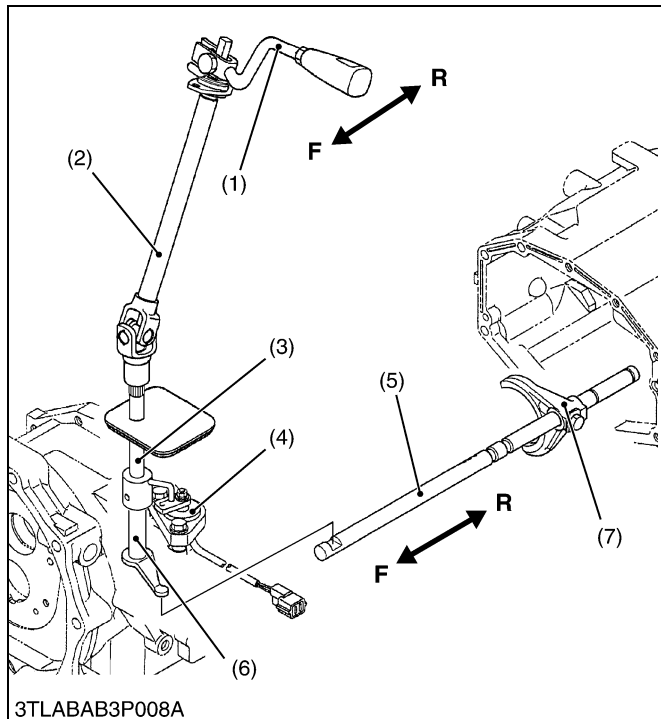

The links are connected from the shift lever (1) to the shift fork (7) as shown in the figure.

When the shift lever (1) is moved to the **F** side, the shift fork (7) is moved toward the **F** side, allowing the operator to shift to forward by means of the shuttle universal joint (2), shuttle shift shaft (3), shift arm (6), and shuttle fork rod (5).

When the shift lever (1) is moved to the **R** side, the shift fork (7) is shifted to reverse position.

- |                             |                |
|-----------------------------|----------------|
| (1) Shuttle Shift Lever     | (6) Shift Arm  |
| (2) Shuttle Universal Joint | (7) Shift Fork |
| (3) Shuttle Shift Shaft     |                |
| (4) Shuttle Switch          |                |
| (5) Shuttle Fork Rod        |                |
- F : Forward Shift**  
**R : Reverse Shift**

W1013763

## (3) Range Gear Shift Lever

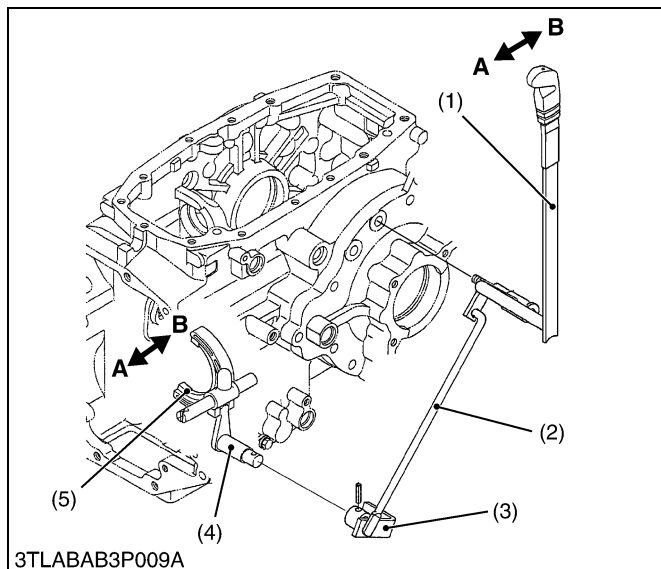

The links from the shift lever (1) to the shift fork (5) are connected as shown in the figure.

When the shift lever (1) is moved to the **A** side, the shift fork (5) is moved to the **A** side by means of the rod (2), sub-arm (3), and shift arm (4), changing the shift arm to the Lo-speed side. When the shift lever (1) is moved to the **B** side, the shift fork (5) is moved to the Hi-speed side.

- |                 |                           |
|-----------------|---------------------------|
| (1) Shift Lever | <b>A : Lo-speed Shift</b> |
| (2) Rod         | <b>B : Hi-speed Shift</b> |
| (3) Sub-arm     |                           |
| (4) Shift Arm   |                           |
| (5) Shift Fork  |                           |

W1013899

## (4) Front Wheel Drive Lever

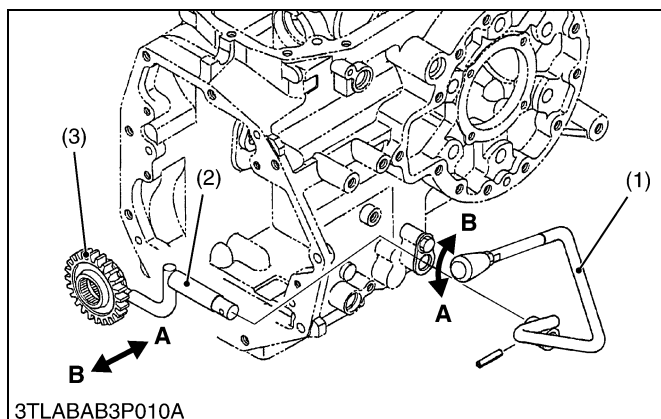

The shift lever (1) is connected directly to the shift fork (2).

When the shift lever (1) is moved to the **A** side, the shift fork (2) is also moved to the **A** side, then the front wheel drive is "**Engaged**".

When the shift lever (1) is moved to the **B** side, the front wheel drive is "**Disengaged**".

- |                  |                       |
|------------------|-----------------------|
| (1) Shift Lever  | <b>A : Engaged</b>    |
| (2) Shift Fork   | <b>B : Disengaged</b> |
| (3) Shifter Gear |                       |

W1014303

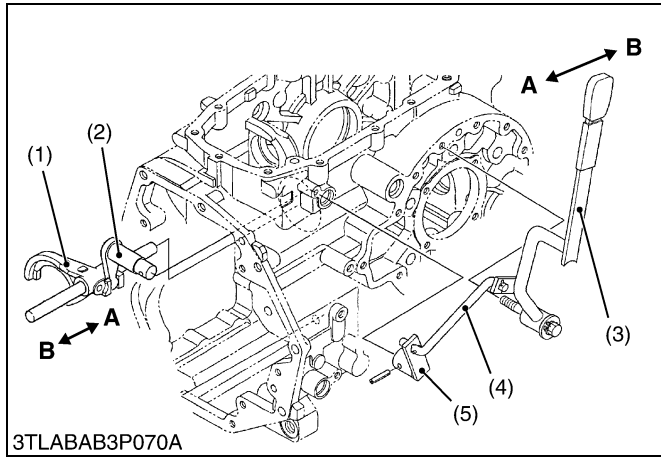
**(5) Creep Gear Shift Lever**

The links are connected from the shift lever (3) to the shift fork (1) as shown in the left figure.

When the shift lever (3) is moved to the **A** side, the shift fork (1) is moved to the **A** side by means of the rod (4), sub-arm (5), and shift arm (2), thereby causing the creep shift.

When the shift lever (3) is moved to the **B** side, the shift fork (1) is moved to the **B** side to cause the normal shift.

- (1) Shift Fork
- (2) Shift Arm
- (3) Shift Lever
- (4) Rod
- (5) Sub-arm

**A : Creep Speed Shift**  
**B : Normal Speed Shift**

W1021330

## 2. GLIDE SHIFT TRANSMISSION (GST) MODEL

### [1] STRUCTURE

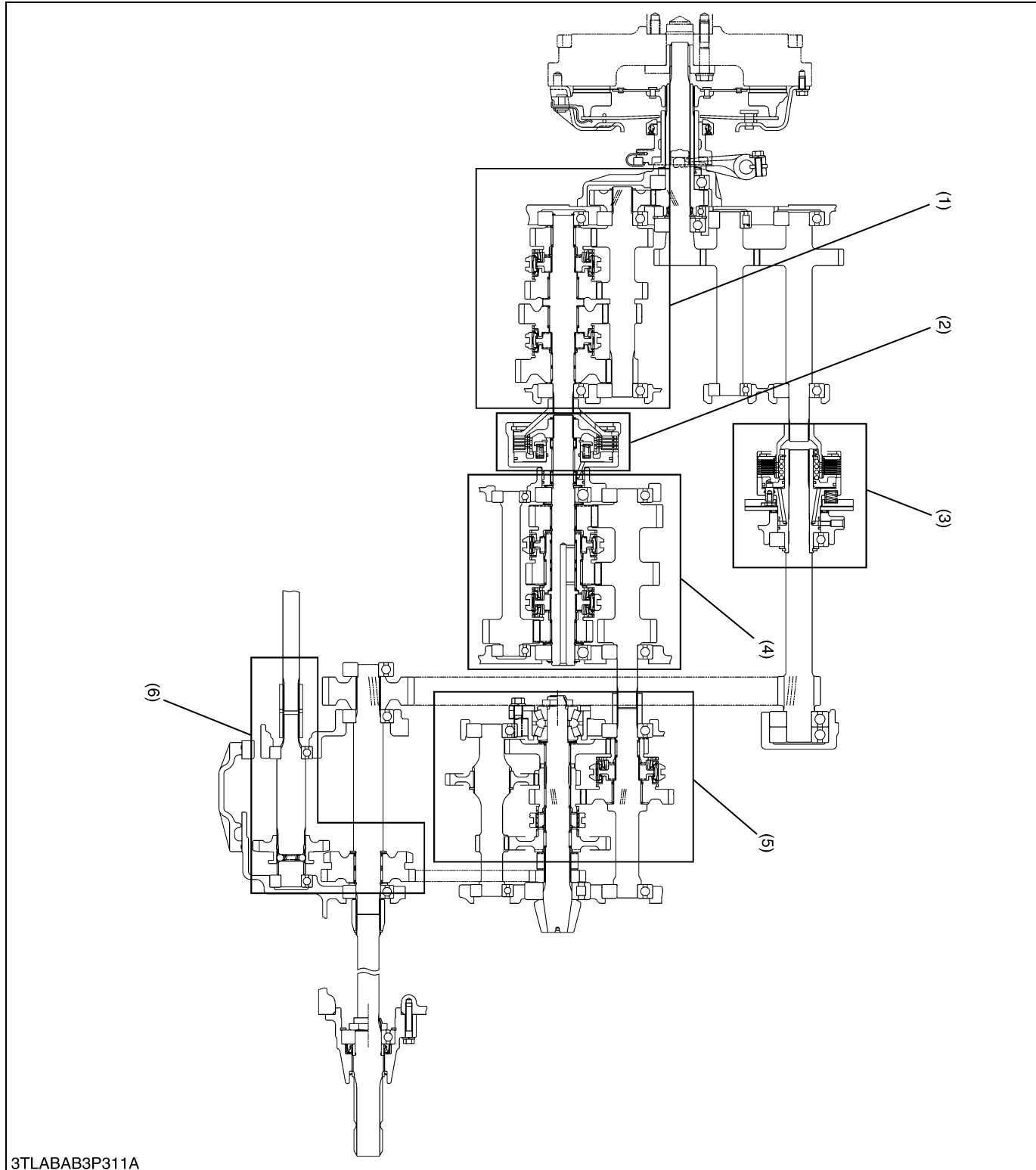

3TLABAB3P311A

(1) Main Gear Shift Section  
(2) Clutch Pack for GST

(3) PTO Clutch Section  
(4) Shuttle Shift Section

(5) Range Gear Shift Section

(6) Front Wheel Drive Shift Section



## [2] CHARACTERISTIC AND SYSTEM OUTLINE

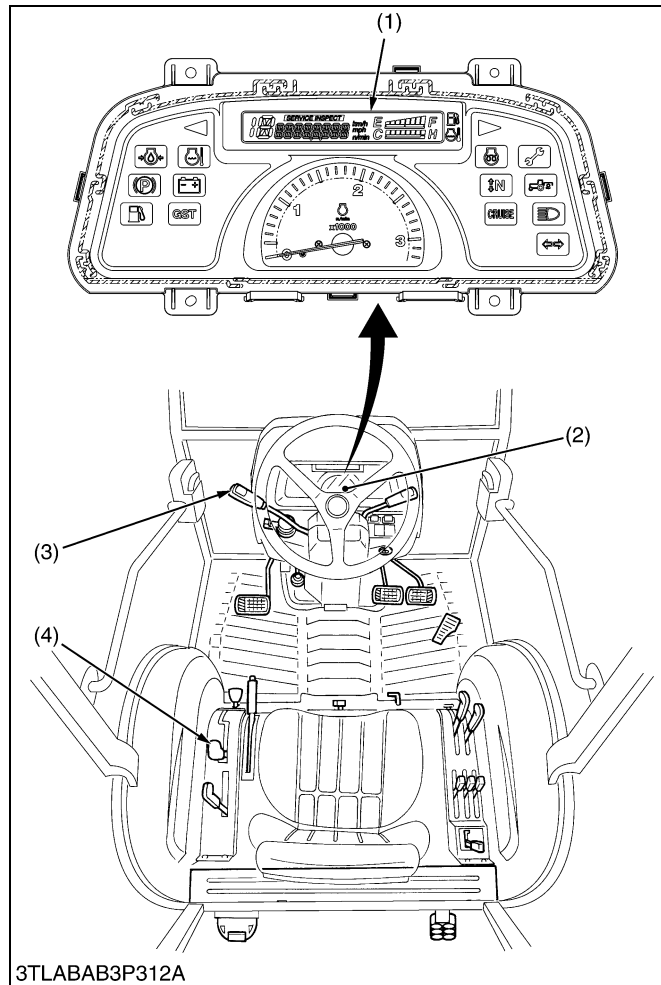

3TLABAB3P312A

The GST of a new version is adapted in the L30 series tractor. In addition to the former GST system that controls the gear shifting and clutch operation hydraulically, this new GST has the function to control these operations electrically.

12 forward and 8 reverse speeds can shift only by operating the main shift lever (GST lever) (4) and shuttle shift lever (3) without the clutch operation as well as the former GST system. In addition, the movement and gear shifting according to the oil temperature and the traveling speed can be achieved by having electronically controlled the GST system, and a smoother operation can be done.

Moreover, because the selected speed and the traveling speed can be confirmed by the liquid crystal display (LCD) (1) of electronic instrument panel (IntelliPanel) (2), it can do a comfortable tractor operation. And it is excellent in service because it can confirm the error indication with an electronic instrument panel (2) when the electric wiring is disconnected or short-circuited.

- |  |                                  |
|--|----------------------------------|
| (1) Liquid Crystal Display (LCD)               | (3) Shuttle Lever                |
| (2) Electronic Instrument Panel (IntelliPanel) | (4) Main Shift Lever (GST Lever) |

W1014583

### [3] POWER TRAIN

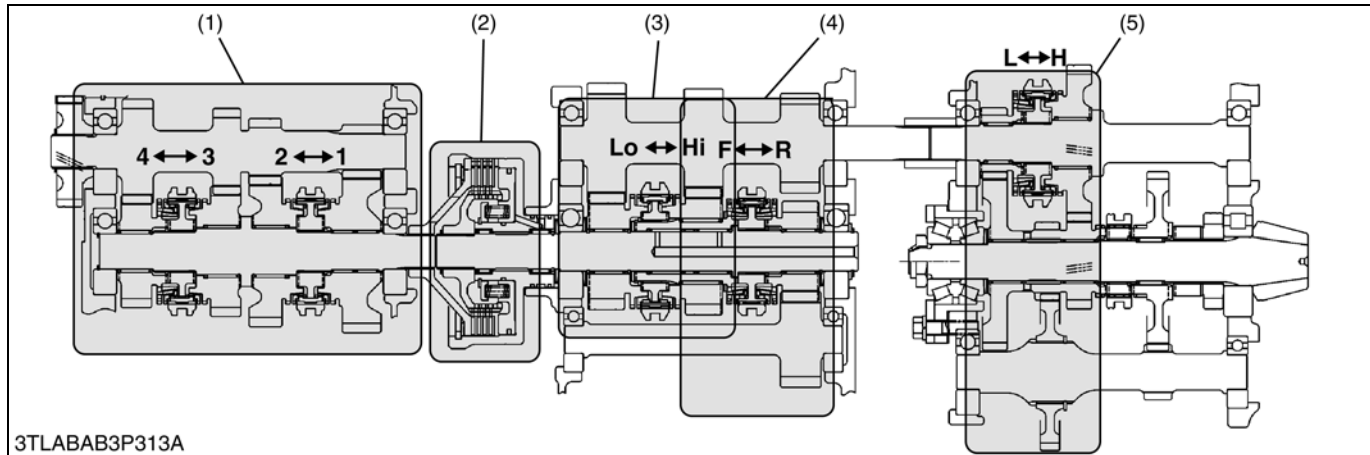

3TLABAB3P313A

(1) Main Shift Section  
(2) GST Clutch Pack

(3) Sub-range Shift Section

(4) Shuttle Shift Section

(5) Main Range Shift Section

The transmission is composed of the fully synchronized gear shifting and the hydraulic clutch as shown above figure. And the double cone type synchromesh is adapted on the 4th speed side of main shift section (1), shuttle shift section (4) and L side of main range shift section (5).

As for the speed changing, only by operating the GST lever, the shifter of the gear changing is moved by hydraulic operation which is electrically controlled. And as for each gear changing, each shift is moved according to the shift pattern input to the electric control unit (ECU). The shift pattern is shown in the table below.

Regarding a double cone type synchromesh system and front wheel drive section, these are basically similar to manual transmission model and refer to page 3-M3 and 3-M4.

#### (Forward shift pattern)

Lever Location at Lever Guide	1	2	3	4	5	6	7	8	9	10	11	12
Display on LCD	1	2	3	4	5	6	7	8	9	10	11	12
(1) Main Shift	1	2	3		4		1		2		3	4
(3) Sub-range Shift	Hi		Lo	Hi	Lo	Hi	Lo	Hi	Lo	Hi		
(5) Main Range Shift	L						H					

#### (Reverse shift pattern)

Lever Location at Lever Guide	1	2	3	4	5	6	7	8	9	10	11	12
Display on LCD	1	2	3		4		5		6		7	8
(1) Main Shift	1	2	3		4		1		2		3	4
(5) Main Range Shift	L						H					

## [4] ELECTRICAL CONTROL SYSTEM

### ■ NOTE

- Only the electrical control system concerning the GST operation has been described in this section. Therefore, refer to “ELECTRICAL SYSTEM” section (Section 9) for a general electrical control system.

### (1) Construction and Function of Components

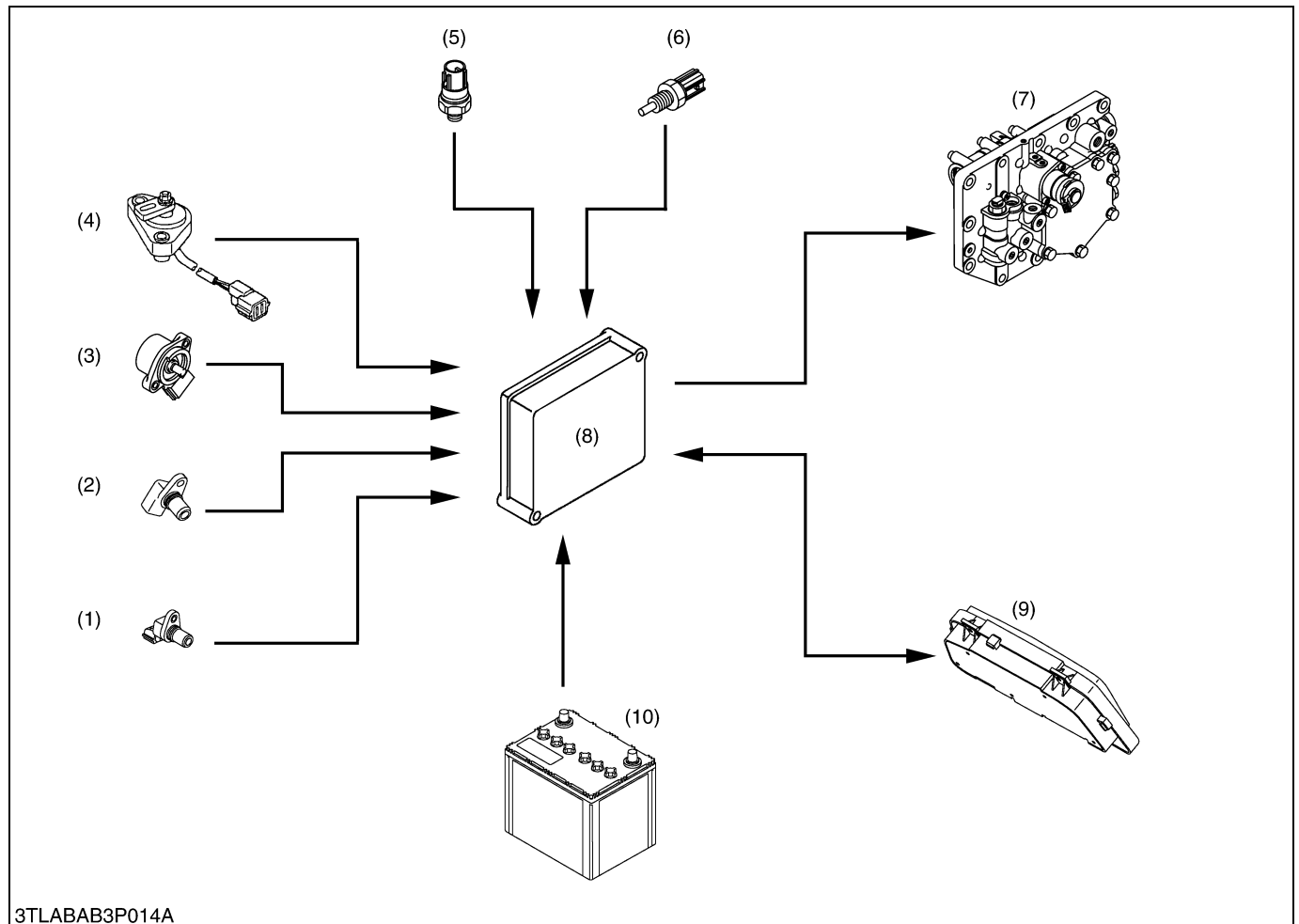

3TLABAB3P014A

- |                              |                            |                              |                                 |
|------------------------------|----------------------------|------------------------------|---------------------------------|
| (1) Traveling Speed Sensor   | (4) Shuttle Switch         | (7) GST Valve                | (8) Electric Control Unit (ECU) |
| (2) Engine Tachometer Sensor | (5) Pressure Switch        | (Solenoid Valve and          | (9) Electronic Instrument Panel |
| (3) GST Lever Sensor         | (6) Oil Temperature Sensor | Proportional Reducing Valve) | (10) Battery                    |

The electric control of the GST system is composed by parts shown in the above figure.

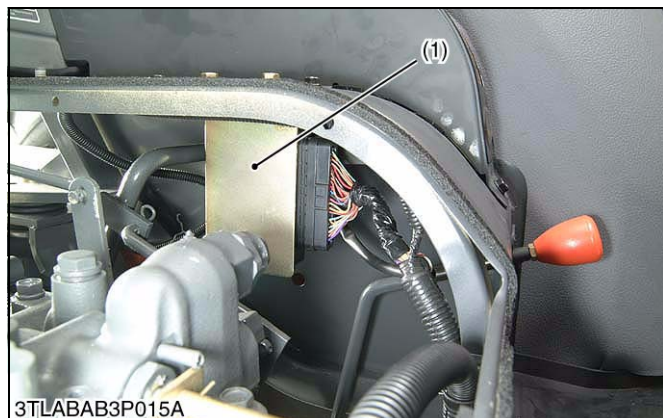

3TLABAB3P015A

### ■ Electric Control Unit (ECU)

This unit incorporates an electronic circuit for various control of GST system and it is equipped on the left under of the platform.

The ECU processes and judges the input data from various switches and sensors and send the signal to various solenoid valves (solenoid valves and proportional reducing valve). At the same time, it also sends the communication data to display the selected-speed and several messages in electronic instrument panel.

- (1) Electric Control Unit

W1015703



3TLABAB3P016A

### ■ Electronic Instrument Panel (IntelliPanel)

The 8 bits CPU is built into this panel.

The electronic instrument panel has functions to receive several data of GST control from the ECU, and output them to the liquid crystal display and the monitor lamps. Moreover, it transmits the model data and the sensor data, etc. also to the ECU.

W1015755

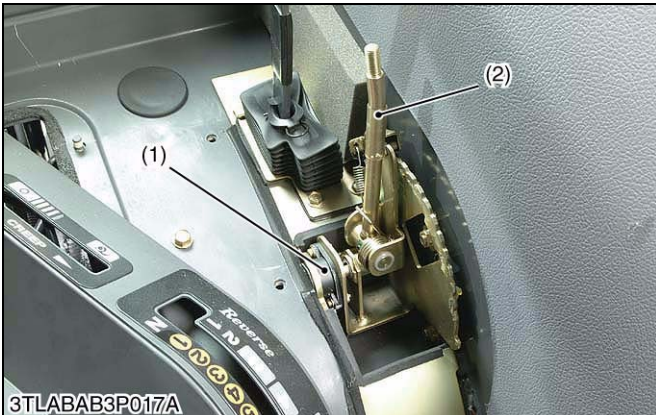

3TLABAB3P017A

### ■ GST Lever Sensor

This sensor has function to detect the GST lever position, and it is equipped on the bottom of the GST lever (2).

This sensor is a variable resistor of the rotation displacement type, and all resistance is 2 k $\Omega$ , and electrically effective angle is 140 degrees. Then, the lever position from **N** to 12 speed is output within the range from about 0.7 to 4.2 voltages.

(1) GST Lever Sensor                      (2) GST Lever

W1015847

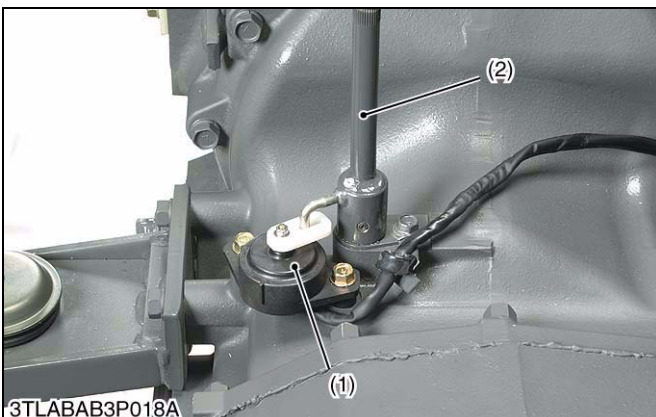

3TLABAB3P018A

### ■ Shuttle Switch

This switch has function to detect the shuttle lever position, and it is equipped on the bottom of the shuttle lever rod (2).

This switch has three contact points, which is **Forward**, **Neutral** and **Reverse**, and detects their position. As for GST control, it judges the shuttle start condition.

(1) Shuttle Switch                      (2) Shuttle Lever Rod

W1015891



3TLABAB3P019A

### ■ Engine Tachometer Sensor

This sensor is to detect the engine rotating speed, and it is equipped on the left side of the engine gear case. This sensor perceives tooth of the fuel camshaft gear and emits the pulse. This pulse is sent to the electronic instrument panel, and converted at the engine speed. The data of engine speed is always sent to the ECU.

(1) Engine Tachometer Sensor

W1015946



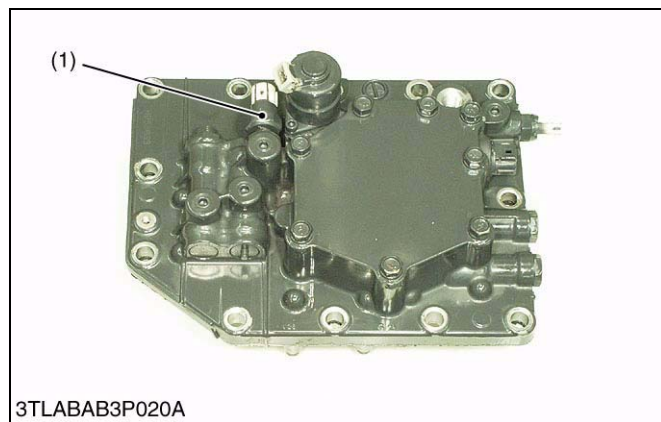

### ■ Pressure Switch

This switch is to detect the gear change completion and hydraulic clutch operation, and it is equipped on the GST valve.

This switch is turned **ON** when the pressure in the GST valve becomes higher than 0.49 MPa (5 kgf/cm<sup>2</sup>, 71 psi) of the pilot pressure, and it is turned **OFF** at a pressure lower than 0.34 MPa (3.5 kgf/cm<sup>2</sup>, 50 psi).

(1) Pressure Switch

W1015998

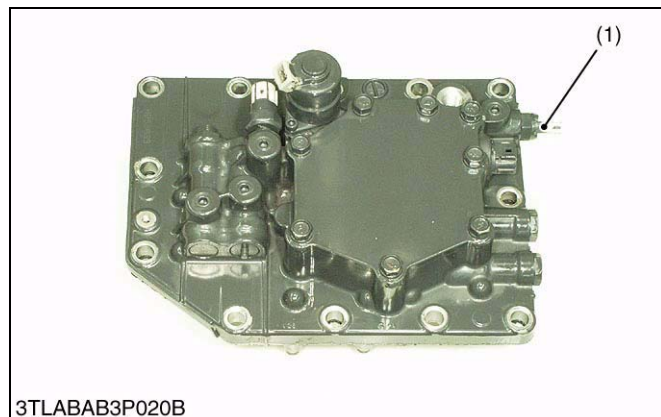

### ■ Oil Temperature Sensor

This sensor is to detect the temperature of transmission fluid, and it is equipped on the GST valve.

This is provided to make correction for driving time and current of proportional reducing valve in accordance with the oil temperature. This is used to thermistor, and it has such characteristics that its resistance decreases at high temperature and increases at low temperature.

(1) Oil Temperature Sensor

W1016064

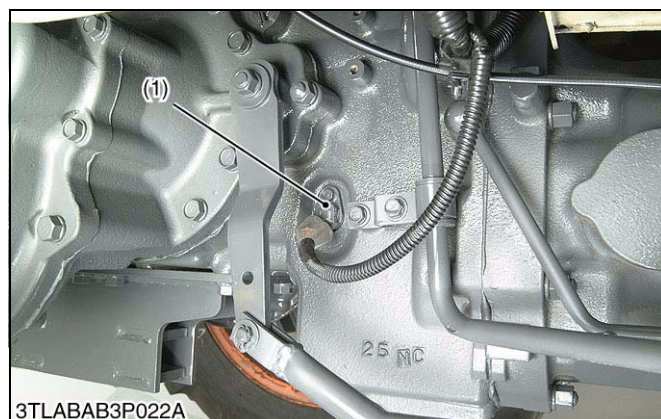

### ■ Traveling Speed Sensor

This sensor is to detect the traveling speed, and it is equipped on the right bottom side of the differential case. This sensor perceives tooth of the front wheel drive gear (3) on the PTO drive shaft (2) and emits pulse. This pulse is sent to the electronic instrument panel, and the traveling speed is calculated by the coefficient which is set according to the tire size. The data of traveling speed is always sent to the ECU.

(1) Traveling Speed Sensor      (3) Front Wheel Drive Gear  
(2) PTO Drive Shaft

W1015587

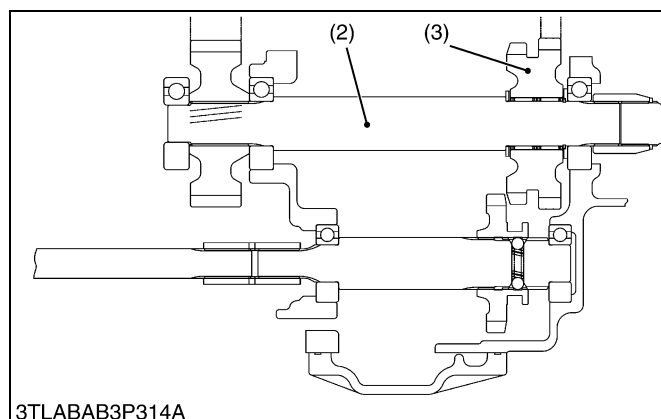

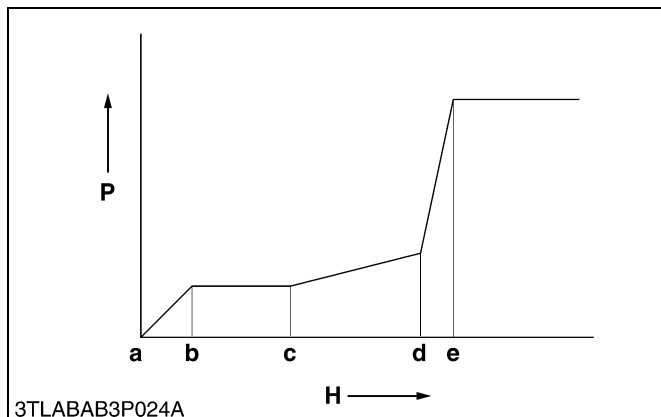
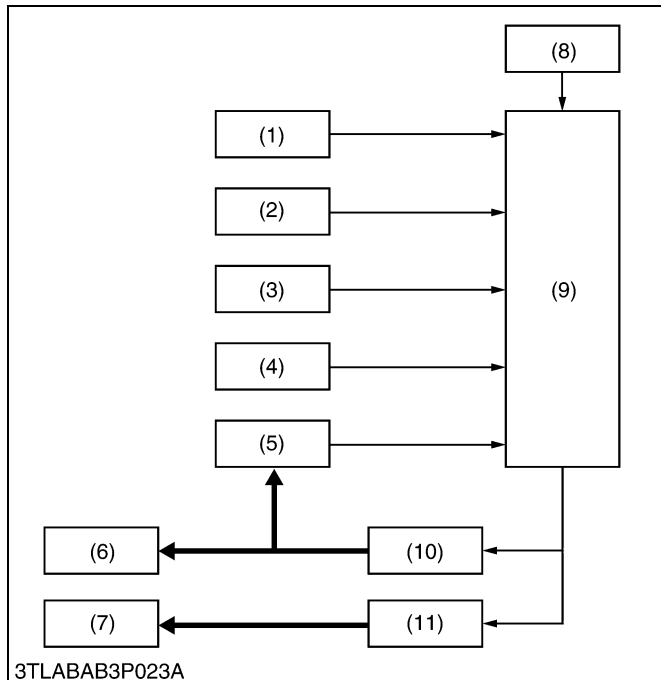
**(2) Electrical Control**

An electrical control of GST system is as follows.

1. Shift the GST lever and shuttle lever to desired position.
2. The output voltage of selected gear shift position is output to microcomputer of the ECU by lever sensor.
3. The ECU detects the gear shift position with GST lever sensor and shuttle switch, and excites various solenoid valves in accordance with selected position.
4. When the desired solenoid is excited, oil is sent to the desired shift piston.
5. A pressure in the circuit is raised because the movement of shift piston shuts the shift check pin. When the pressure in the circuit reaches 0.49 MPa (5 kgf/cm<sup>2</sup>, 71 psi), the pressure switch becomes **ON**.
6. By means of the pressure switch's **ON**, the ECU detects the present condition (traveling speed, engine speed and oil temperature) from various sensors, and pressure in the hydraulic clutch is raised according to the respective condition.

**NOTE**

- **By means of speed increasing, speed decreasing, traveling speed, engine speed and oil temperature, the indicated pressure period from c to d is controlled at appropriate pressure respectively.**
7. A pressurizing to hydraulic clutch has been done until it reaches the system pressure, and pressure in the clutch is maintained at this state.

- |                                  |   |
|----------------------------------|---|
| (1) Oil Temperature Sensor       | <b>P : Pressure</b>                         |
| (2) Engine Tachometer Sensor     | <b>H : Time</b>                             |
| (3) Traveling Speed Sensor       | <b>a : Starting of clutch engaging</b>      |
| (4) Shuttle Switch               | <b>b : Low-pass pressure</b>                |
| (5) Pressure Switch              | <b>c : Starting of pressurized</b>          |
| (6) Shift Piston                 | <b>c to d : Specified pressure from ECU</b> |
| (7) Clutch Valve                 | <b>e : Gear shifting completion</b>         |
| (8) GST Lever Sensor             |   |
| (9) ECU                          |   |
| (10) Solenoid Valves             |   |
| (11) Proportional Reducing Valve |   |

W1016324

## [5] HYDRAULIC CONTROL SYSTEM

### (1) Hydraulic Circuit and System Outline

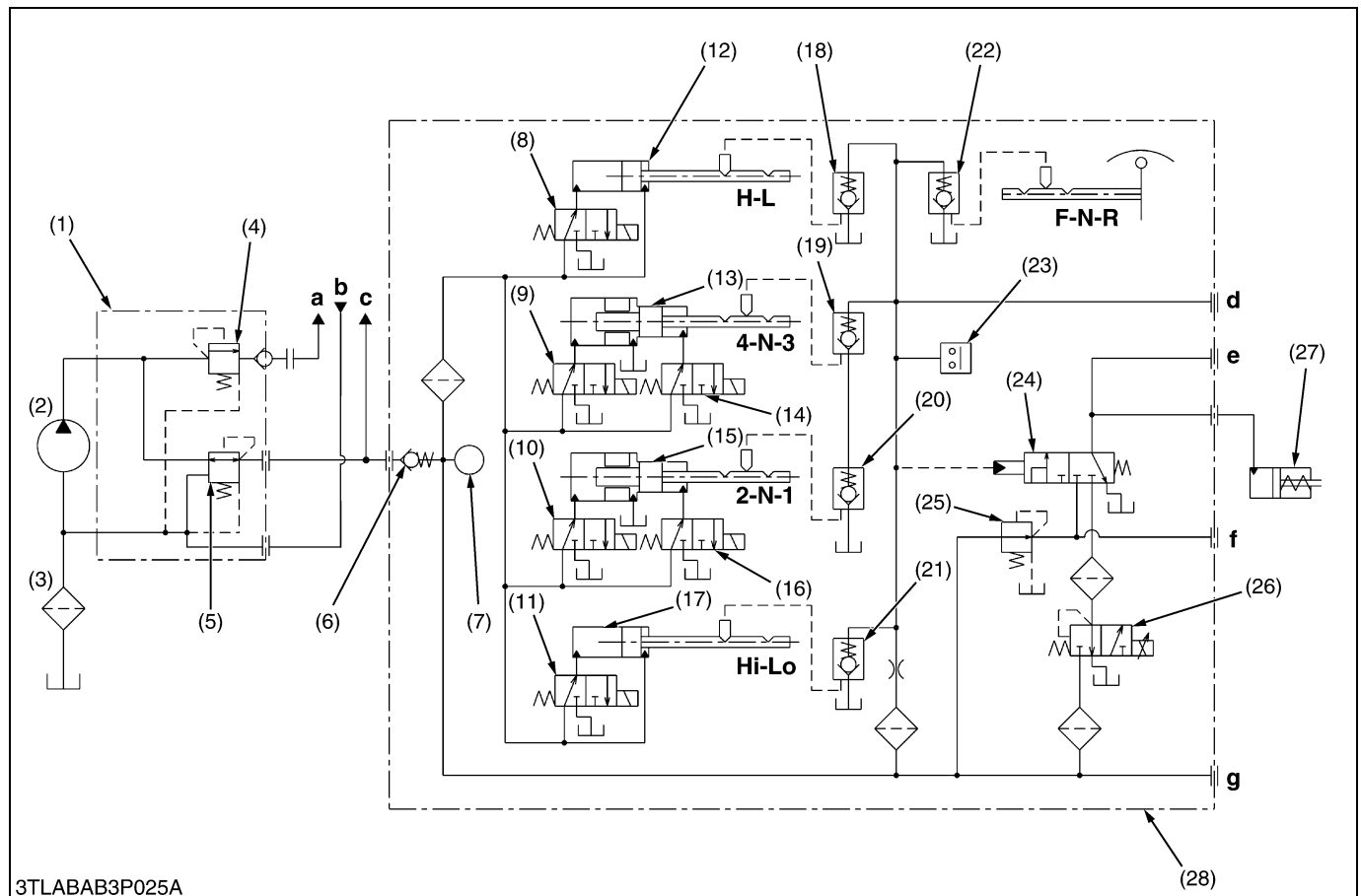

- (1) Regulating Valve Assembly
- (2) Hydraulic Pump
- (3) Hydraulic Oil Filter
- (4) Regulating Valve
- (5) Pressure Reducing Valve
- (6) Check Valve
- (7) Oil Temperature Sensor
- (8) Solenoid Valve 6  
(Main Range Shift)
- (9) Solenoid Valve 3
- (10) Solenoid Valve 1

- (11) Solenoid Valve 5  
(Sub-range Shift)
- (12) Shift Piston  
(Main Range Shift)
- (13) 3-4 Shift Piston
- (14) Solenoid Valve 4
- (15) 1-2 Shift Piston
- (16) Solenoid Valve 2
- (17) Shift Piston (Sub-range Shift)
- (18) Shift Check Valve  
(Main Range Shift)

- (19) 3-4 Shift Check Valve
- (20) 1-2 Shift Check Valve
- (21) Shift Check Valve  
(Sub-range Shift)
- (22) Shift Check Valve, Shuttle
- (23) Pressure Switch
- (24) Clutch Valve
- (25) Low-pass Valve
- (26) Proportional Reducing Valve
- (27) GST Clutch
- (28) GST Valve Assembly

- a : To Steering Controller**
- b : From Steering Controller**
- c : To PTO Clutch Valve**
- d : Check port for pilot pressure**
- e : Check port for clutch pressure**
- f : Check port for Low-pass pressure**
- g : Check port for system pressure**



- Oil is supplied from the power steering hydraulic pump (2) while running the engine.
- The oil entering the regulating valve assembly (1) flows through the pressure reducing valve (5) to the GST circuit. This oil pressure is maintained at a fixed level by the pressure reducing valve (5).
- When the GST lever is operated, the desired shift solenoids (8), (9), (10), (11), (14) or (16) are excited according to the output voltage from the GST lever sensor.
- When the solenoid valve is operated, oil is supplied to corresponded shift pistons (12), (13), (15) or (17), and the shift piston is moved. The shift arm that is moved by the shift piston moves shifter of synchromesh to shift the gear. At this time, GST clutch (27) has been disengaging until gear shifting is completed. The GST clutch (27) is engaging except where the condition is neutral, is gear shifting and is engine stopping.
- Pressure in the pilot circuit rises because the shift check valves (18), (21) and (19) or (20) are shut by the movements of shift pistons at the same time as completing gear shifting.
- By means of pressure rising of the circuit, the clutch valve (24) is actuated. And, oil flows through the low-pass valve (25) and the proportional reducing valve (26) to the GST clutch (27). This oil flows until becoming the compound pressure which is both of setting pressure for closing of low-pass valve, and controlled indication pressure of the proportional reducing valve.

**(Reference)**

- Setting pressure for closing of low-pass valve : 0.24 MPa (2.5 kgf/cm<sup>2</sup>, 34.1 psi)
- Because pressure in the GST clutch (27) is gradually pressurized by function of proportional reducing valve (26), clutch is able to engage without shock and smoothly.
  - When the pressure in the circuit rises to the system pressure, pressure is maintained. And the GST clutch is maintained at engaging condition until the next gear shifting.

**State of energizing of solenoid****(Forward)**

	N	1st	2nd	3rd	4th	5th	6th	7th	8th	9th	10th	11th	12th
Solenoid 1(10)		ON						ON	ON				
Solenoid 2 (16)			ON							ON	ON		
Solenoid 3 (9)				ON	ON							ON	
Solenoid 4 (14)						ON	ON						ON
Solenoid 5 (11)				ON		ON		ON		ON			
Solenoid 6 (8)	(ON)	ON	ON	ON	ON	ON	ON						

**(Reverse)**

	N	1st	2nd	3rd	4th	5th	6th	7th	8th
Solenoid 1 (10)		ON				ON			
Solenoid 2 (16)			ON				ON		
Solenoid 3 (9)				ON				ON	
Solenoid 4 (14)					ON				ON
Solenoid 6 (8)	(ON)	ON	ON	ON	ON				

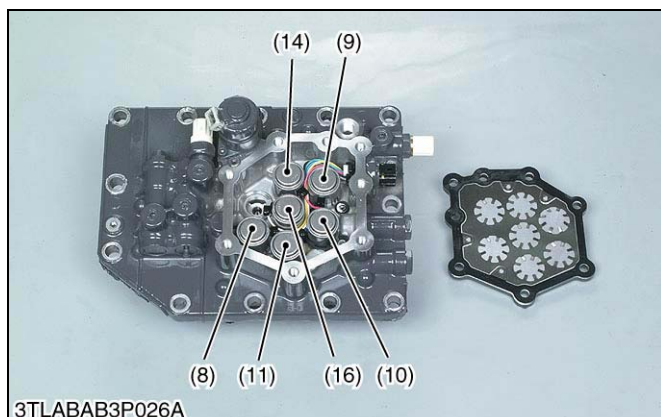

No.	Solenoid	Color of wiring
(10)	Solenoid 1	Black
(16)	Solenoid 2	White
(9)	Solenoid 3	Red
(14)	Solenoid 4	Green
(11)	Solenoid 5, Sub-range Lo-Hi	Blue
(8)	Solenoid 6, Main range L-H	Yellow

W1019092

## (2) Construction and Function of Components

### (A) Regulating Valve

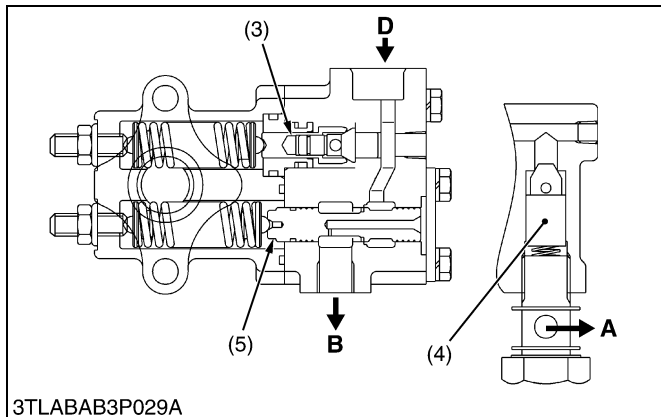
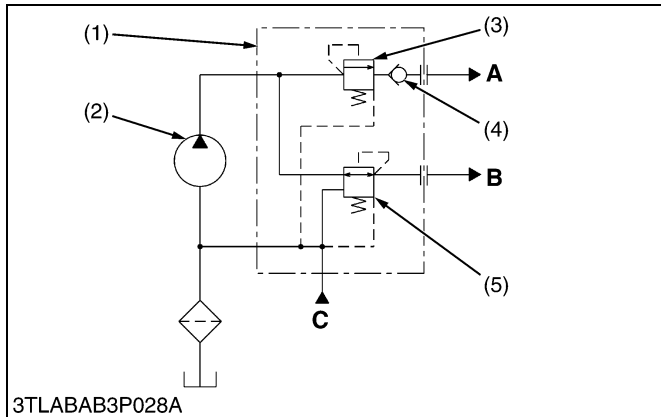
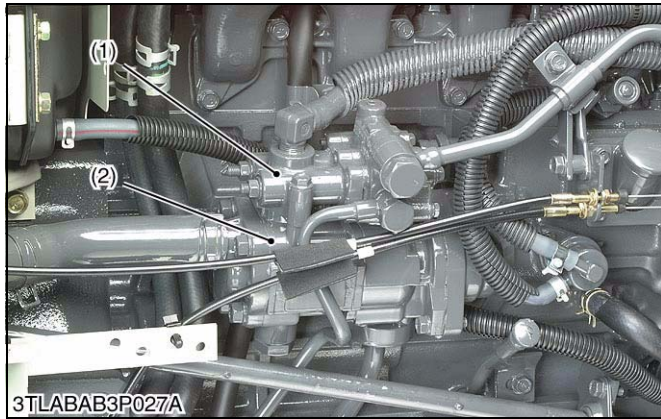

The oil from the hydraulic pump for the power steering system flows to the GST circuit to set the pressure of the circuit. Other oil flows to the power steering circuit.

The oil from the power steering hydraulic pump (2) flows through the pressure reducing valve (5) to the GST circuit. When the oil is filled into the circuit, the pressure reducing valve (5) is closed to maintain the pressure in the GST system circuit to 2.45 MPa (25.0 kgf/cm<sup>2</sup>, 356 psi).

The oil from the power steering pump passes through the regulating valve (3) and check valve (4), and then it flows to power steering circuit. The regulating valve (3) is provided to maintain 2.94 MPa (30.0 kgf/cm<sup>2</sup>, 427 psi) at inlet pressure of the pressure reducing valve (5) except when the power steering is operated. Thereby getting 2.45 MPa (25.0 kgf/cm<sup>2</sup>, 356 psi) of the GST circuit pressure.

- (1) Regulating Valve Assembly     **A : To Power Steering Circuit**
- (2) Hydraulic Pump                    **B : To GST Circuit and PTO Clutch Valve**
- (3) Regulating Valve
- (4) Check Valve                         **C : From Power Steering Circuit**
- (5) Pressure Reducing Valve         **D : From Hydraulic Pump**

W1019304

**(B) GST Valve**

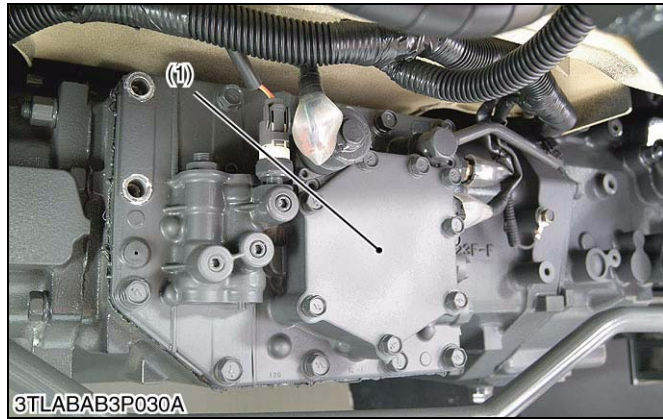

**■ GST Valve Assembly**

The GST valve assembly is installed at the left side of the transmission mid case. In the GST valve assembly, many parts comprising the system are installed, including the solenoid valves, shift pistons, shift check valves, low-pass valve, proportional reducing valve, clutch valve, check valves, sensor and switches. The GST valve assembly functions as the central unit of the GST system.

- |                                   |  |
|-----------------------------------|--|
| (1) GST Valve Assembly            | (6) Connector for Oil Temperature Sensor |
| (2) Clutch Valve                  | (7) Connector for Solenoid Valve         |
| (3) Low-pass Valve                | (8) Solenoid Valves                      |
| (4) Connector for Pressure Switch |  |
| (5) Proportional Reducing Valve   |  |

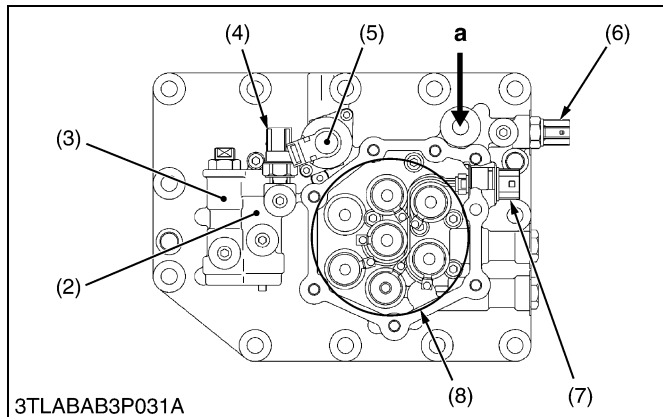

**a : Oil From Regulating Valve**

W1019626

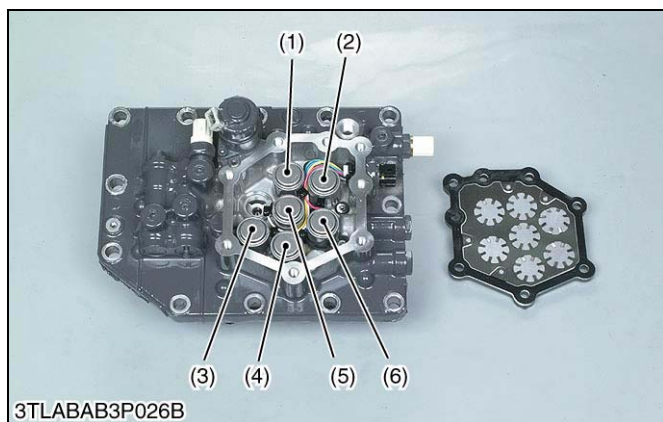

**■ Solenoid Valve**

When the GST lever is operated, the solenoid valve controls the flow of oil according to the gear shifting operation.

When the solenoid is not excited, oil from regulating valve flows to the shift piston through the surrounding of the ball (10) in the valve. When the solenoid is excited, plunger (9) presses the ball against the valve seat (11) to open the unload passage (12), and drain the oil.

- |   |                     |
|---|---------------------|
| (1) Solenoid Valve 4                    | (9) Plunger         |
| (2) Solenoid Valve 3                    | (10) Ball           |
| (3) Solenoid Valve 6 (Main Range Shift) | (11) Valve Seat     |
| (4) Solenoid Valve 5 (Sub-range Shift)  | (12) Unload Passage |
| (5) Solenoid Valve 2                    |                     |
| (6) Solenoid Valve 1                    |                     |
| (7) Coil                                |                     |
| (8) Solenoid Valve                      |                     |

**T : Drain Port**  
**R : IN Port**  
**P : To Shift Piston**

W1019949

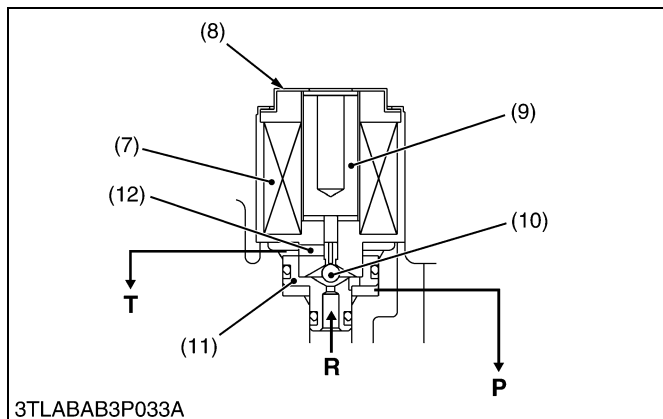

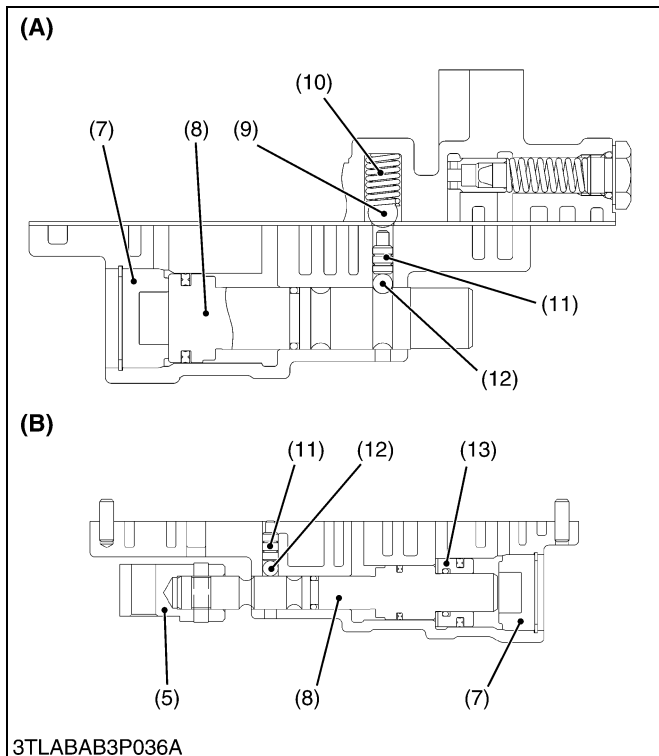
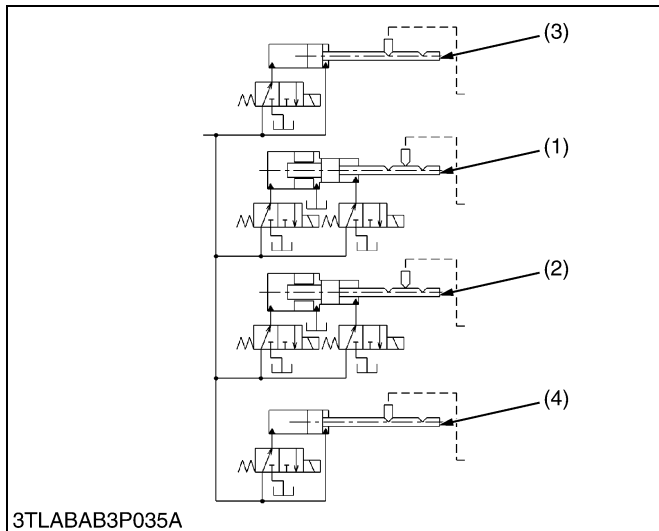
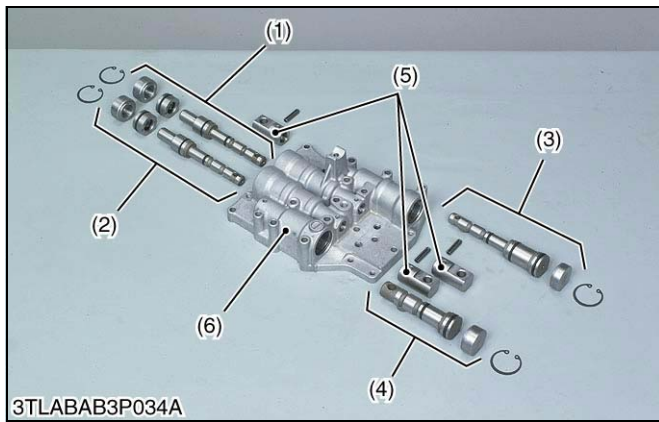

■ Shift Piston

The shift pistons (1), (2), (3), (4) are actuated by the oil distributed by the each solenoid valve. At the tip of these shift pistons (1), (2), (3) are installed the shifters (5), which are connected to each shift rod and shift the gear.

There are neutral positions in 1-2 shift piston (2) and 3-4 shift piston (1).

- (1) 3-4 Shift Piston
  - (2) 1-2 Shift Piston
  - (3) Main Range Shift Piston
  - (4) Sub-range Shift Piston
  - (5) Shifter
  - (6) Valve Body
  - (7) Cover
  - (8) Piston
  - (9) Ball for Check Valve
  - (10) Spring
  - (11) Check Pin
  - (12) Ball for Detent
  - (13) Neutral Piston
- A : Shift Piston for Main Range Shift**  
**B : 1-2 and 3-4 Shift Piston**

W1020109



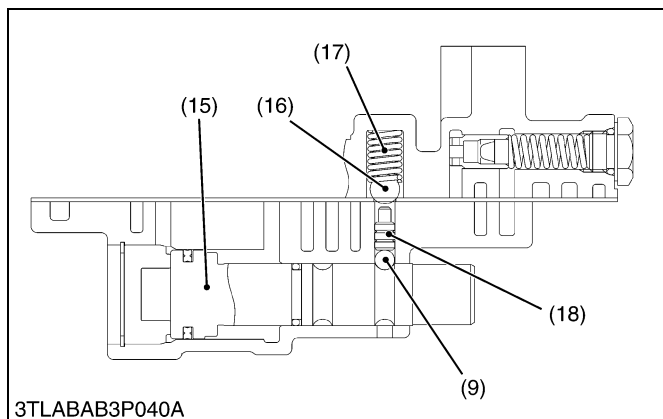
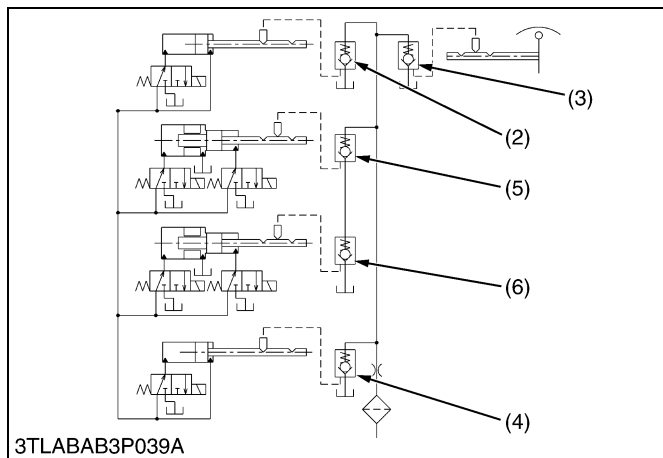
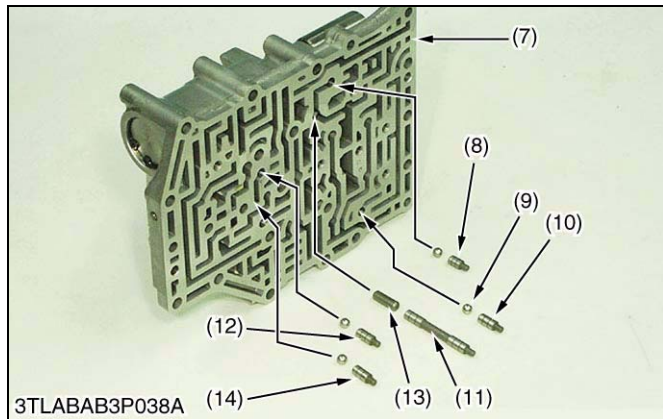
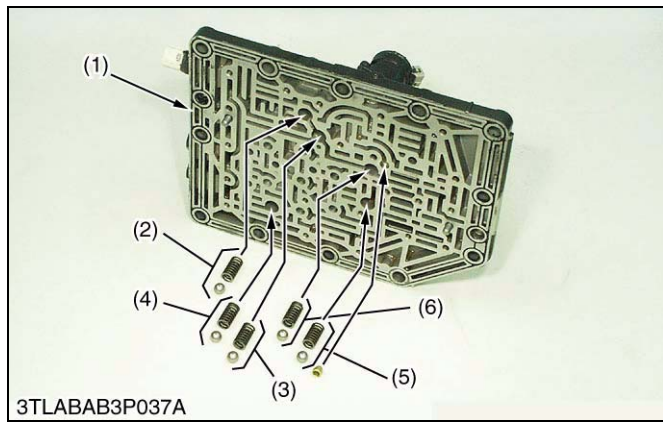

### Shift Check Valve

The shift check valves (2), (3), (4), (5), (6) are provided on each shift piston and the shuttle shift rod.

From the start to the end of gear shifting, the shift check valves (2), (4), (5), (6) of the shift pistons are opened because the ball (9) of the check pin (18) is on the straight portion, the oil in the pilot circuit of the clutch valve passes through the shift check valves (2), (3), (4), (5), (6) to be drained into the tank, causing the GST clutch to be disengaged.

When the gear shifting is completed, the ball (9) of the check pin (18) enters the groove of the shift piston; the check valve is closed, causing the pilot circuit pressure to rise and the clutch valve to open. Thus, the oil flows into the GST clutch to engage it. The 1-2 shift check valve (6) and 3-4 shift check valve (5) compose a serial circuit. When either valve is closed, the oil in the pilot circuit will not be drained into the tank.

In case of the shuttle shifting, the shift check valve (3) is opened and closed by the groove of the shuttle shift rod.

Note that the shuttle shift fork rod has a slot into which the shift fork mounting bolt is inserted. Therefore, when the shuttle shift lever is moved, the shuttle shift fork rod is moved before the shuttle shift fork is moved, disengaging the clutch pack and thus moving the shuttle shift fork.

- |                                  |                                     |
|----------------------------------|-------------------------------------|
| (1) GST Valve Cover              | (10) Main Range Check Pin           |
| (2) Main Range Shift Check Valve | (11) Shuttle Check Pin              |
| (3) Shuttle Shift Check Valve    | (12) 3-4 Check Pin                  |
| (4) Sub-range Shift Check Valve  | (13) Pin                            |
| (5) 3-4 Shift Check Valve        | (14) 1-2 Check Pin                  |
| (6) 1-2 Shift Check Valve        | (15) Shift Piston (Sub-range Shift) |
| (7) GST Valve Body               | (16) Ball                           |
| (8) Sub-range Check Pin          | (17) Spring                         |
| (9) Ball for Detent              | (18) Check Pin                      |

W1020427

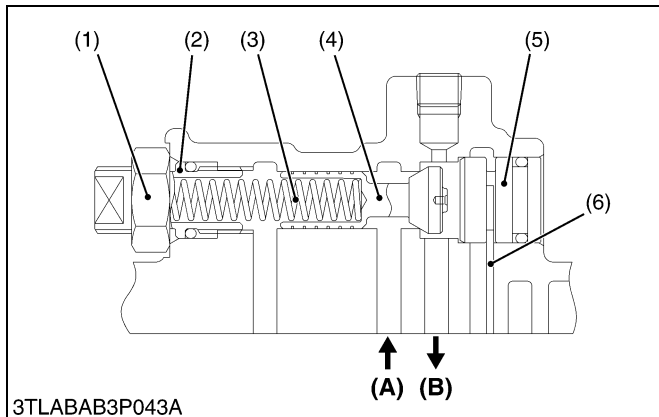
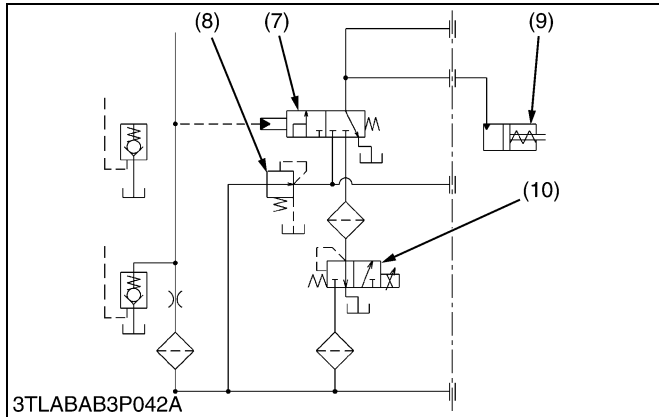
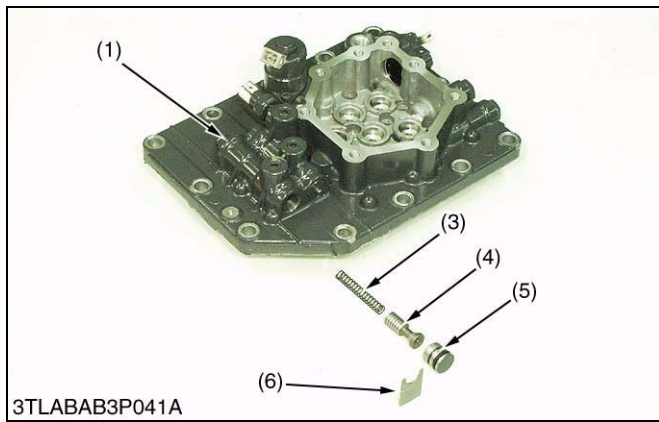

■ **Low-pass Valve**

After completion of the gear shifting, the low-pass valve (8) opens immediately to flow oil into the GST clutch (9), to promote the engagement of the clutch.

When the gear shifting starts, the oil in the GST clutch (9) passes the clutch valve (7) to be drained into the tank. So prior to beginning of the GST clutch connection and after completion of gear shifting, it is necessary to flow oil to the GST clutch quickly. It is the low-pass valve that does this operation with the proportional reducing valve (10) simultaneously.

The oil from the regulating valve flows in from the **IN-port (A)**, passes through the low-pass valve poppet (4), flows out from **OUT-port (B)**, and flows to the clutch valve (7) and clutch (9). When the pressure on the side of the **OUT-port (B)** reaches setting pressure, the poppet (4) pushes the spring (3) to close the circuit.

- (1) Nut
  - (2) Adjuster
  - (3) Spring
  - (4) Poppet
  - (5) Plug
  - (6) Stopper Plate
  - (7) Clutch Valve
  - (8) Low-pass Valve
  - (9) GST Clutch
  - (10) Proportional Reducing Valve
- (A) IN-Port**  
**(B) OUT-Port**

W1020861

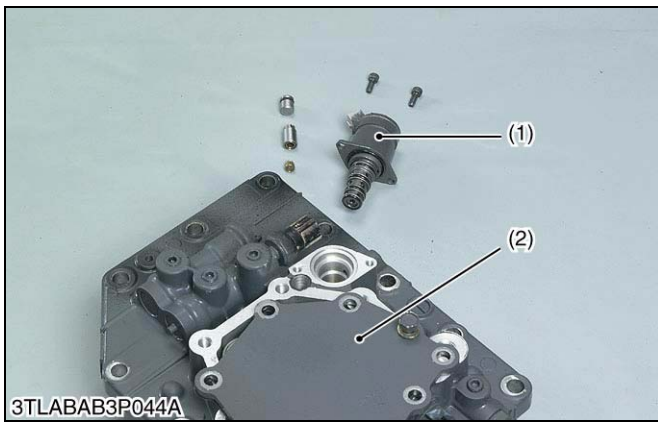

3TLABAB3P044A

## ■ Proportional Reducing Valve

After the gear shifting is completed, this valve has function which gradually rises the pressure in the clutch (4) in order to make a clutch engaging for without shock and smoothly.

When the gear shifting is completed, the pressure switch is turned **ON**. By means of turning on the pressure switch, the microcomputer of ECU calculates and judges the charging of pressure and its time according to the oil temperature sensor and gear shifting period, and the traveling speed and speed acceleration according to the traveling speed sensor. By these instructions from microcomputer of ECU, the proportional reducing valve adjusts pressure in the clutch to become a appropriate acceleration.

- |                                 |  |
|---------------------------------|--|
| (1) Proportional Reducing Valve | <b>P : IN Port (From Regulating Valve)</b> |
| (2) GST Valve Assembly          | <b>C : OUT Port (To Clutch Valve)</b>      |
| (3) Clutch Valve                | <b>T : DRAIN Port (To Tank)</b>            |
| (4) GST Clutch                  |  |
| (5) Filter                      |  |

W1021268

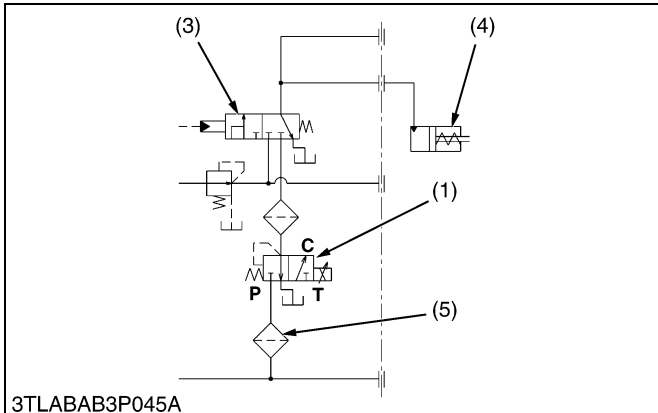

3TLABAB3P045A

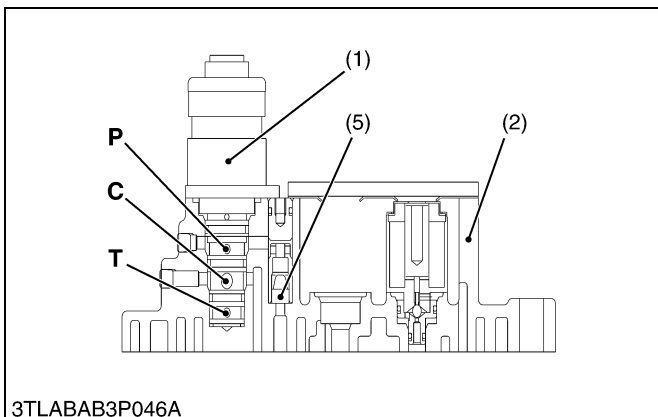

3TLABAB3P046A



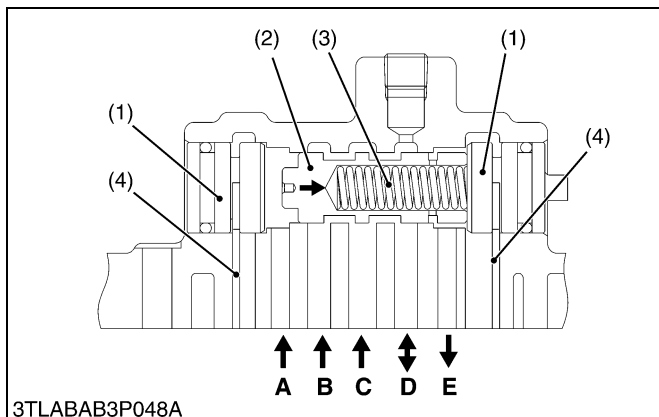
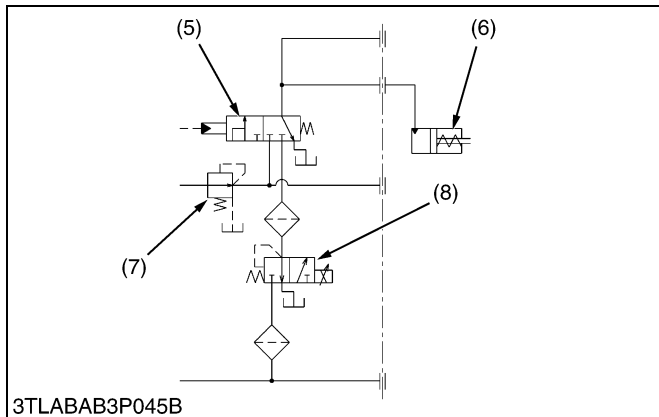
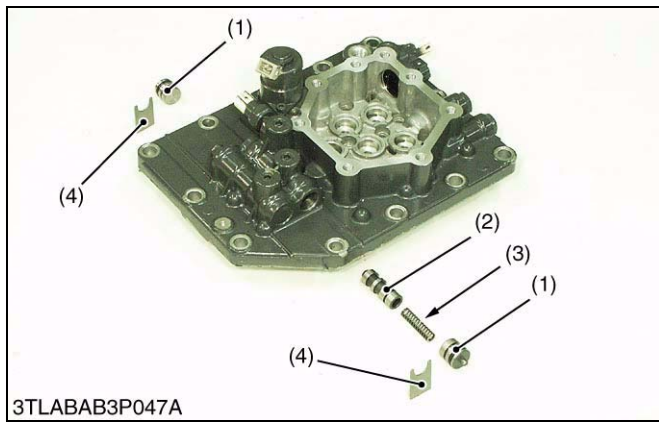

### ■ Clutch Valve

The clutch valve (5) changes the flow of the oil flowing to the GST clutch to carry out **“ENGAGE”** / **“DISENGAGED”** of the clutch.

Except for during gear shifting, the oil of the pilot circuit flows in from the **A**-port to push the spool to the right when the pilot circuit is pressurized. Therefore, the oil from the low-pass valve (7) and proportional reducing valve (8) flows in from **B** and **C**-port, flows out from the **D**-port, and flows to the GST clutch (6).

When the pilot circuit pressure is zero, that is, from the start to the left with the spring (3) to cut the oil flow of **B** and **C**-port, and stopping the oil flow to the GST clutch (6). Furthermore, the oil of the GST clutch flows in from **D**-port, and is drained from **E**-port, and then the GST clutch is disengaged.

- |                                 |  |
|---------------------------------|--|
| (1) Plug                        | <b>A</b> : A-Port (From Pilot Circuit)               |
| (2) Spool                       | <b>B</b> : B-Port (From Low-pass Valve)              |
| (3) Spring                      | <b>C</b> : C-Port (From Proportional Reducing Valve) |
| (4) Stopper Plate               | <b>D</b> : D-Port (To GST Clutch)                    |
| (5) Clutch Valve                | <b>E</b> : E-Port (To Tank)                          |
| (6) GST Clutch                  |  |
| (7) Low-pass Valve              |  |
| (8) Proportional Reducing Valve |  |

W1021514

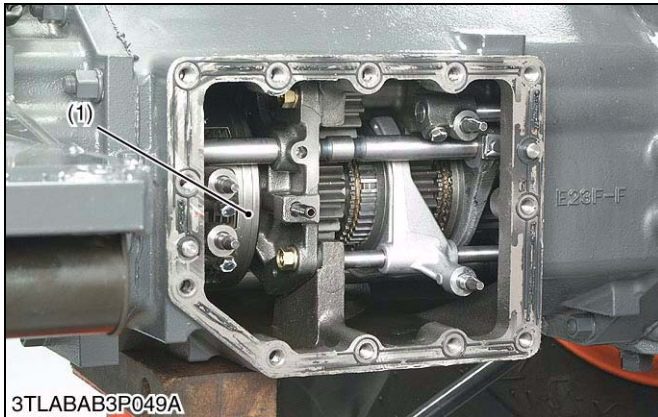
**(C) GST Clutch**

3TLABAB3P049A

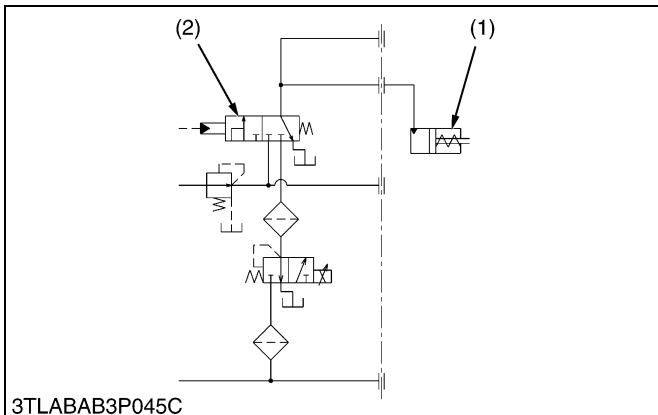

3TLABAB3P045C

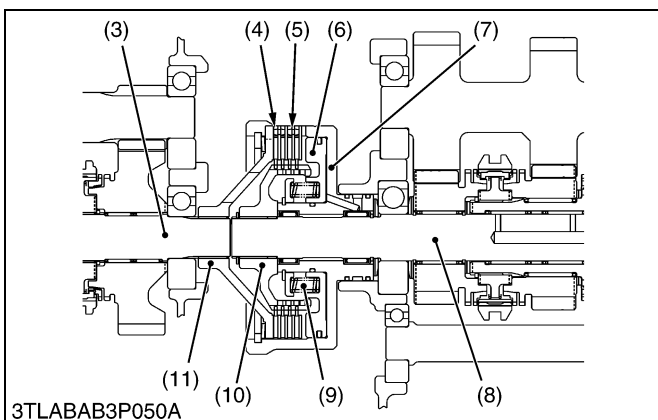

3TLABAB3P050A

The GST clutch is hydraulic multiple plate type and is provided between the counter shaft (3) and the shuttle shaft (8), and it “engages” and “disengages” the power from the engine. This is controlled by the operation of clutch valve (2).

■ **Engaging (When the shift gear is at desired position while engine is running)**

The oil from clutch valve (2) flows in to push the return spring (9) and the piston (6). The piston is pushed to the left by the oil, thereby pushing the clutch discs (4) and the plates (5) to transmit the power.

■ **Disengaging (When the engine stop, the shift levers are neutral position, between from start to end of the gear shifting)**

The oil of the GST clutch (1) is pushed out with return spring (9) and piston (6), and flowed to the tank.

- |                   |                        |
|-------------------|------------------------|
| (1) GST Clutch    | (7) Clutch Case        |
| (2) Clutch Valve  | (8) Shuttle Shaft      |
| (3) Counter Shaft | (9) Return Spring      |
| (4) Clutch Disc   | (10) Clutch Output Hub |
| (5) Plate         | (11) Clutch Input Hub  |
| (6) Piston        |                        |

W1021896

**[6] SHIFT LINKAGE MECHANISM**

For shift linkage mechanism of “Shuttle Lever” and “Front Wheel Drive Lever”, refer to page 3-M6.

### 3. HYDROSTATIC TRANSMISSION (HST) MODEL

#### [1] STRUCTURE

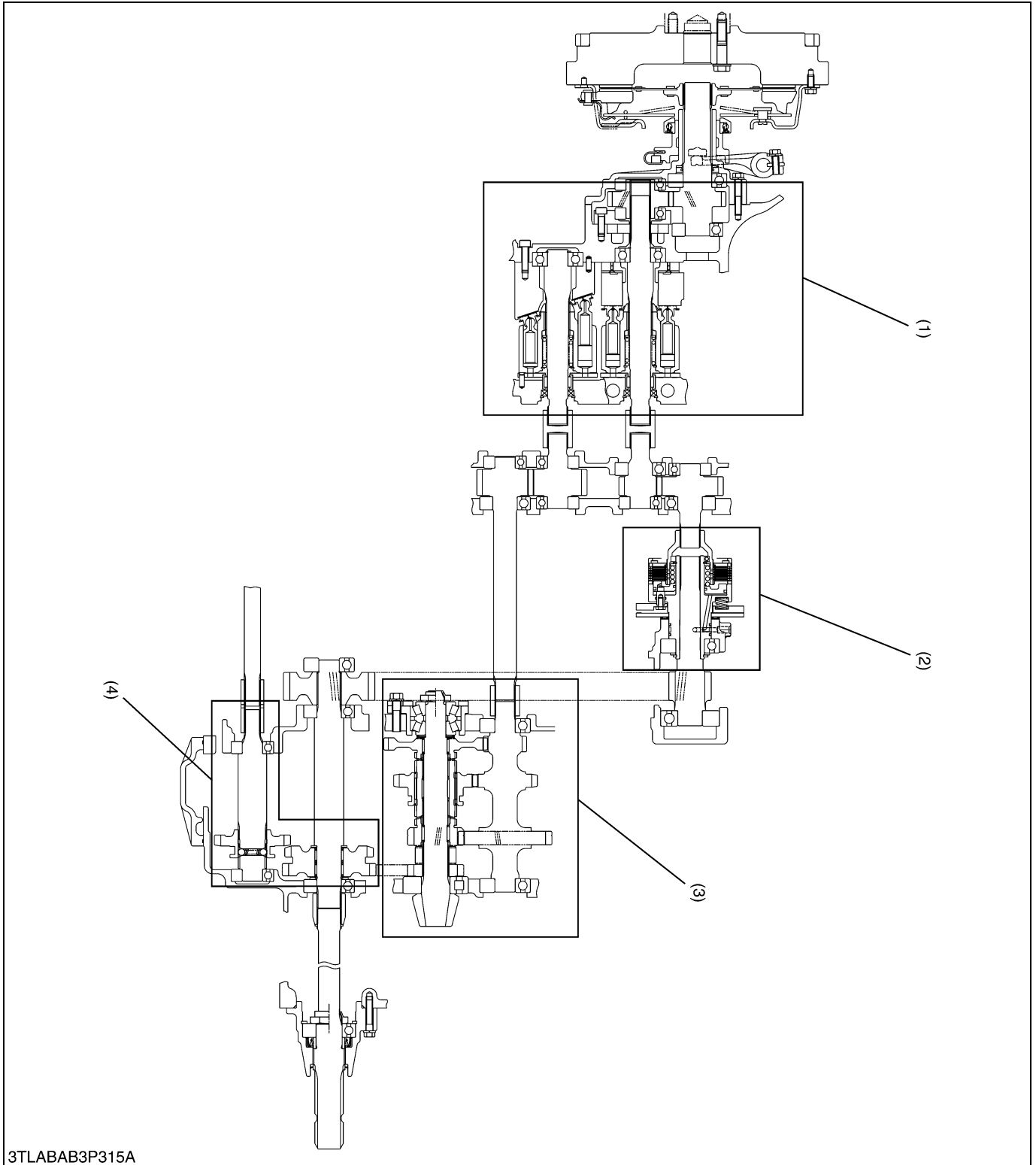

3TLABAB3P315A

(1) Hydrostatic Transmission Section

(2) PTO Clutch Section

(3) Range Gear Shift Section

(4) Front Wheel Drive Shift Section

## [2] POWER TRAIN

The transmission of this model consists of a series of gears and shafts as shown in previous page. The traveling system is chiefly composed of hydrostatic transmission section, range gear shift section and front wheel drive section.

### (1) Hydrostatic Transmission (HST)

#### (A) Structure

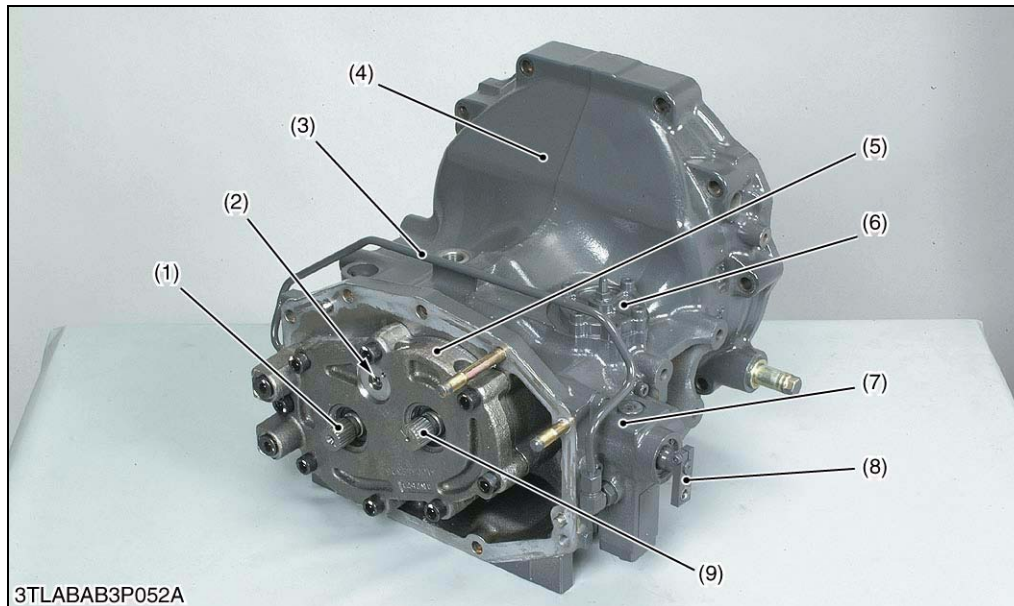

- (1) Output Shaft (Motor Shaft)
- (2) Case Relief Valve
- (3) Bypass Pipe (Servo Pipe)
- (4) HST Case (Clutch Housing)
- (5) Port Block Cover
- (6) Servo Piston
- (7) Servo Regulator
- (8) Control Lever (Connect to HST Pedal)
- (9) Input Shaft (Pump Shaft)
- (10) Charge Pump
- (11) Outlet Port (To Oil Cooler)
- (12) Check and High Pressure Relief Valve (Reverse)
- (13) Check and High Pressure Relief Valve (Forward)
- (14) Charge Relief Valve

W1022595

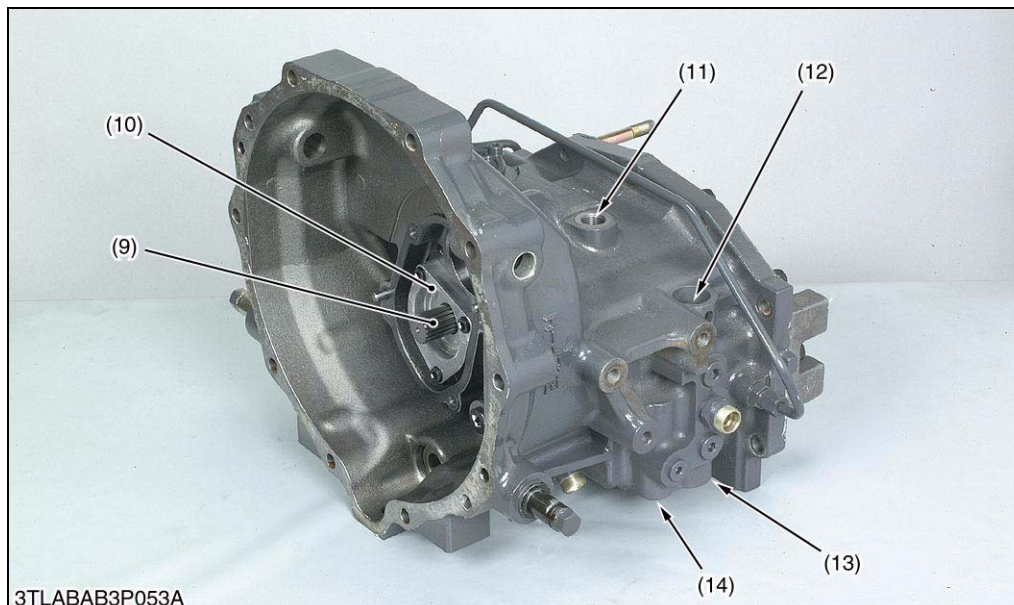

The HST of L30 series tractor is a built-in type to the clutch housing, and HST with the servomechanism is adapted. The servomechanism controls the pedal operation of HST hydraulically. As a result, the HST pedal feels extremely light and smoother pedal operation can be done.

HST assembly is chiefly composed of HST case (clutch housing), variable displacement piston pump, fixed displacement piston motor, charge pump, servo-regulator and various valves. Refer to the next page for detailed parts in the HST.

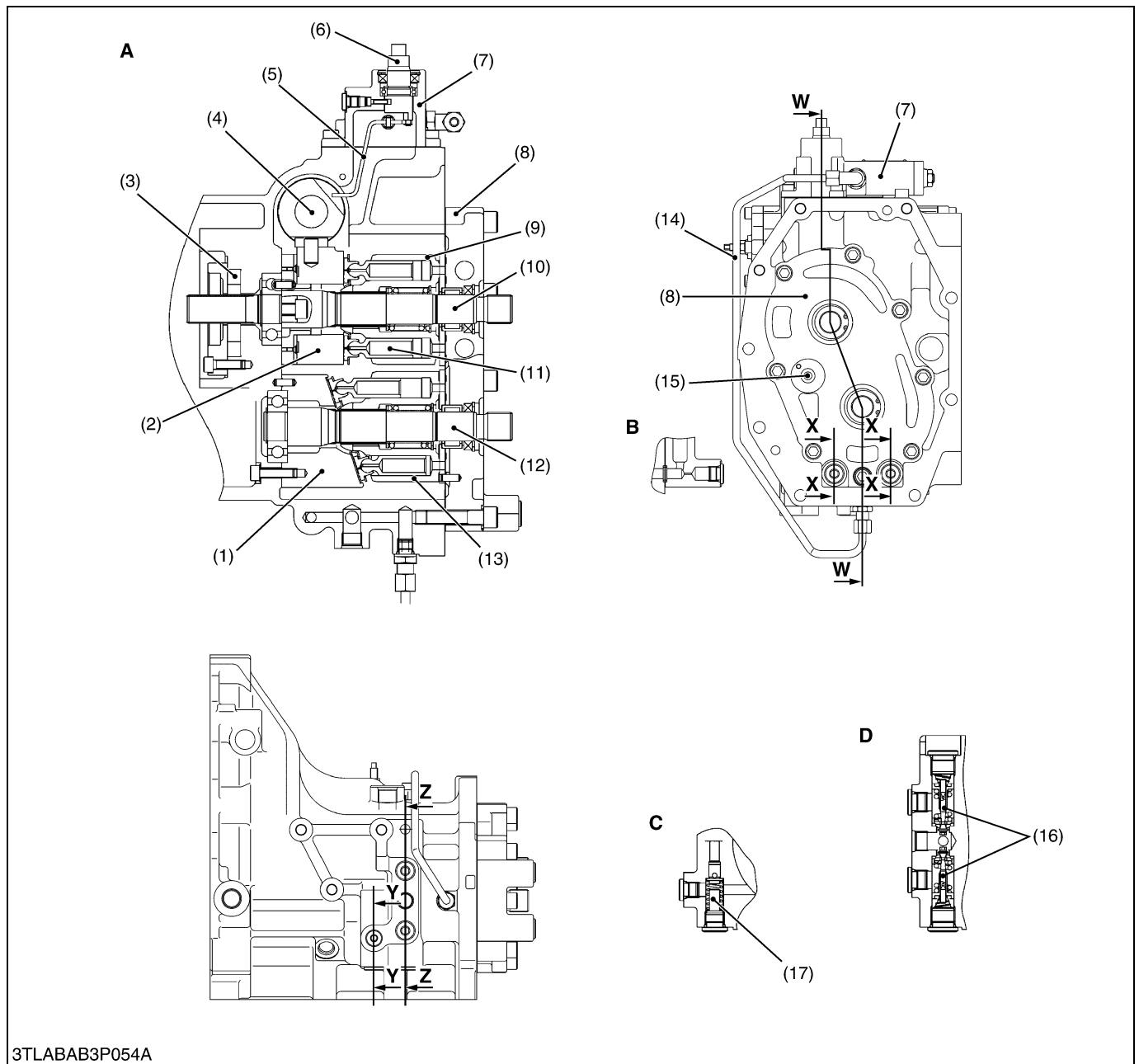

- (1) Fixed Swashplate
- (2) Variable Swashplate
- (3) Charge Pump
- (4) Servo Piston
- (5) Feedback Rod
- (6) Control Shaft

- (7) Regulator Assembly
- (8) Port Block Cover
- (9) Cylinder Block (Pump)
- (10) Input Shaft (Pump Shaft)
- (11) Piston
- (12) Output Shaft (Motor Shaft)

- (13) Cylinder Block (Motor)
- (14) Bypass Pipe (Servo Pipe)
- (15) Case Relief Valve
- (16) Check and High Pressure Relief Valve
- (17) Charge Relief Valve

- A : Sectional View W-W**
- B : Sectional View X-X**
- C : Sectional View Y-Y**
- D : Sectional View Z-Z**

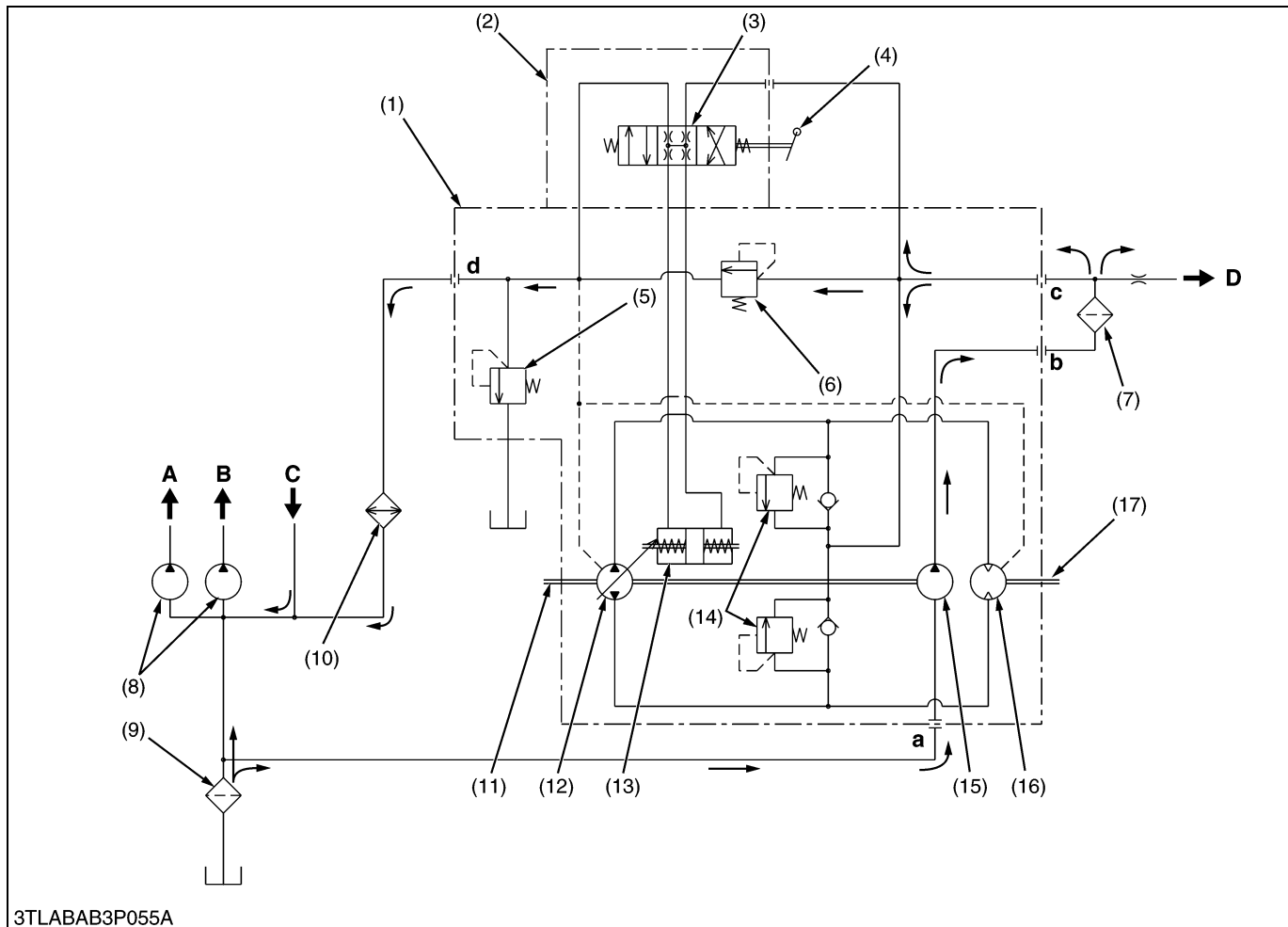
**(B) Oil Flow**

- |                               |                               |   |  |
|-------------------------------|-------------------------------|---|--|
| (1) HST Assembly              | (8) Hydraulic Pump            | (14) Check and High Pressure Relief Valve | <b>C : From Steering Controller</b>      |
| (2) Servo Regulator Assembly  | (9) Filter                    | (15) Charge Pump                          | <b>D : To PTO Clutch Valve</b>           |
| (3) Regulator Valve           | (10) Oil Cooler               | (16) Motor Cylinder Block                 | <b>a : a-port (In from suction line)</b> |
| (4) Control Lever (HST Pedal) | (11) Input Shaft (Pump Shaft) | (17) Output Shaft (Motor Shaft)           | <b>b : b-port (Out by charge pump)</b>   |
| (5) Case Relief Valve         | (12) Pump Cylinder Block      |   | <b>c : c-port (In from charge pump)</b>  |
| (6) Charge Relief Valve       | (13) Servo Piston             |   | <b>d : d-port (Out from HST circuit)</b> |
| (7) Filter                    |                               |   | <b>A : To Hydraulic Block</b>            |
|                               |                               |   | <b>B : To Steering Controller</b>        |

Oil flows in HST case from **a**-port, and is sent to **b**-port with the charge pump (15). Oil from **b**-port is sent to the HST circuit and the PTO clutch circuit through the filter (7). Moreover, the oil of the HST circuit sent to **c**-port is flowed into the servo regulator (2) and HST main circuit. At this time, the pressure in the regulator, HST main circuit (closed circuit) and PTO clutch circuit is controlled with the charge relief valve (6). The oil in regulator is used for the movement of servo piston (13) which is operated by the regulator valve (3) and HST pedal (4). And the oil in the HST main circuit gets circulated between the variable displacement piston pump (12) and the fixed displacement piston motor (16), which forms a closed circuit.

On the other hand, surplus oil with the charge relief valve (6) flows out from **d**-port, and is sent to the suction line through the oil cooler (10). And the case relief valve (5) controls pressure in the HST case.

**(Reference)**

- Valve Setting Pressure [Oil temperature : 40 to 60 °C (104 to 140 °F)]
  - Charge Relief Valve : 2.25 to 2.45 MPa (23 to 25 kgf/cm<sup>2</sup>, 327 to 355 psi)
  - Check and High Pressure Relief Valve : 33.3 to 36.3 MPa (340 to 370 kgf/cm<sup>2</sup>, 4836 to 5262 psi)
  - Case Relief Valve : 0.29 MPa (3.0 kgf/cm<sup>2</sup>, 42.7 psi)

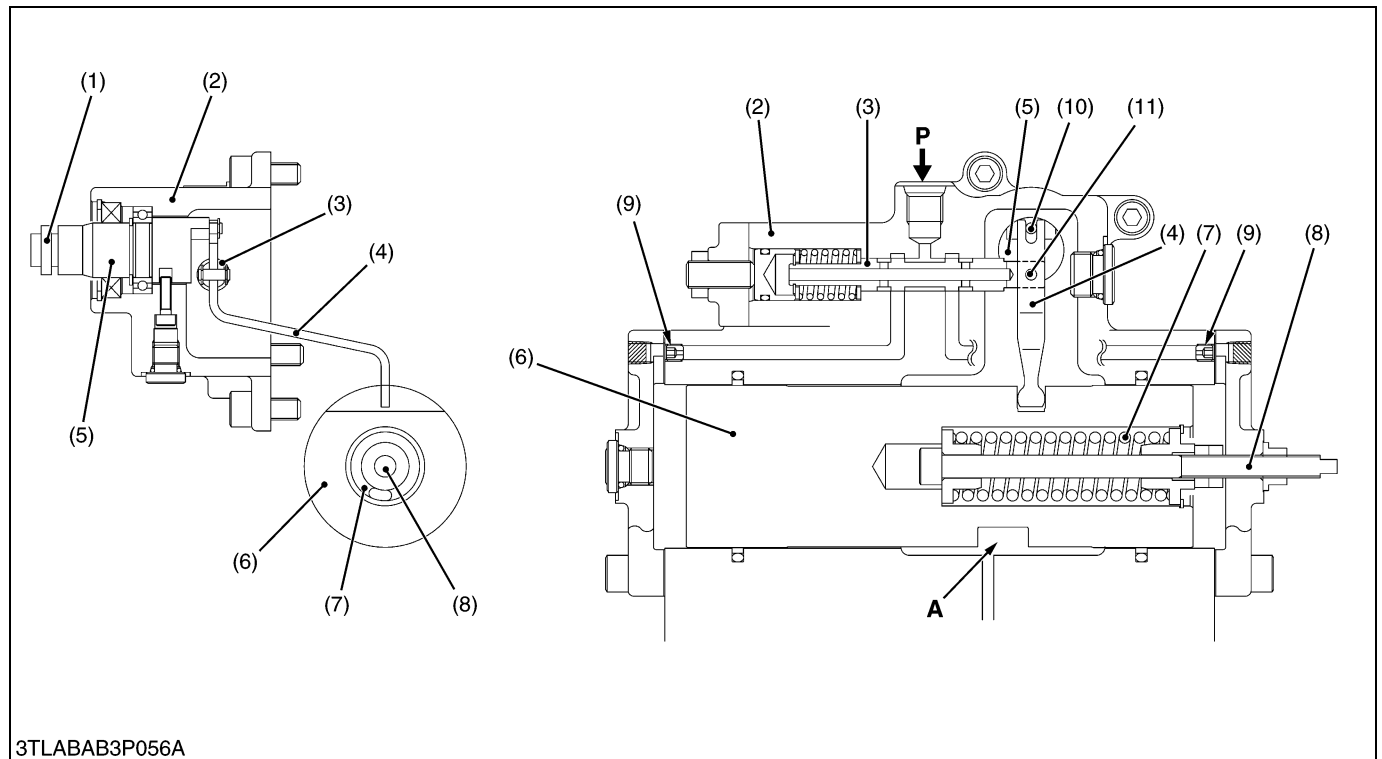

**(C) Function of Components****■ Servomechanism**

3TLABAB3P056A

- |  |                    |                                     |  |
|--|--------------------|-------------------------------------|--|
| (1) Control Lever (Connected to HST Pedal) | (4) Feedback Lever | (8) Piston Adjusting Screw          | <b>A : Slit for Connection of Swashplate</b> |
| (2) Regulator Valve Assembly               | (5) Control Arm    | (9) Orifice                         | <b>P : IN Port (From Bypass Pipe)</b>        |
| (3) Spool                                  | (6) Servo Piston   | (10) Pin A (Fixed with Control Arm) |  |
|  | (7) Spring         | (11) Pin B (Fixed with Spool)       |  |

As for the servomechanism, the regulator (2) and servo piston (6) are chiefly composed. The regulator is connected to the HST pedal through linkages, and controls the flow of oil to the servo piston by the pedal operation.

The servo piston moved by hydraulic force, is connected to the pump cylinder swashplate. Therefore, a tilt angle of swashplate is varied by servo piston movement.

As for the regulator and the servo piston, it is connected with feedback lever (4), and the movement of the piston is restricted according to the amount of depressing of the HST pedal.

Refer to Workshop Manual of “**TRACTOR MECHANISM**” (Code No. 97897-18200) for the operation of the servomechanism, that is, the operation of regulator and servo piston.

**■ Valves**

As for the mechanism and function of check and high pressure relief valve, charge relief valve and case relief valve, refer to Workshop Manual of “**TRACTOR MECHANISM**” (Code No. 97897-18200).

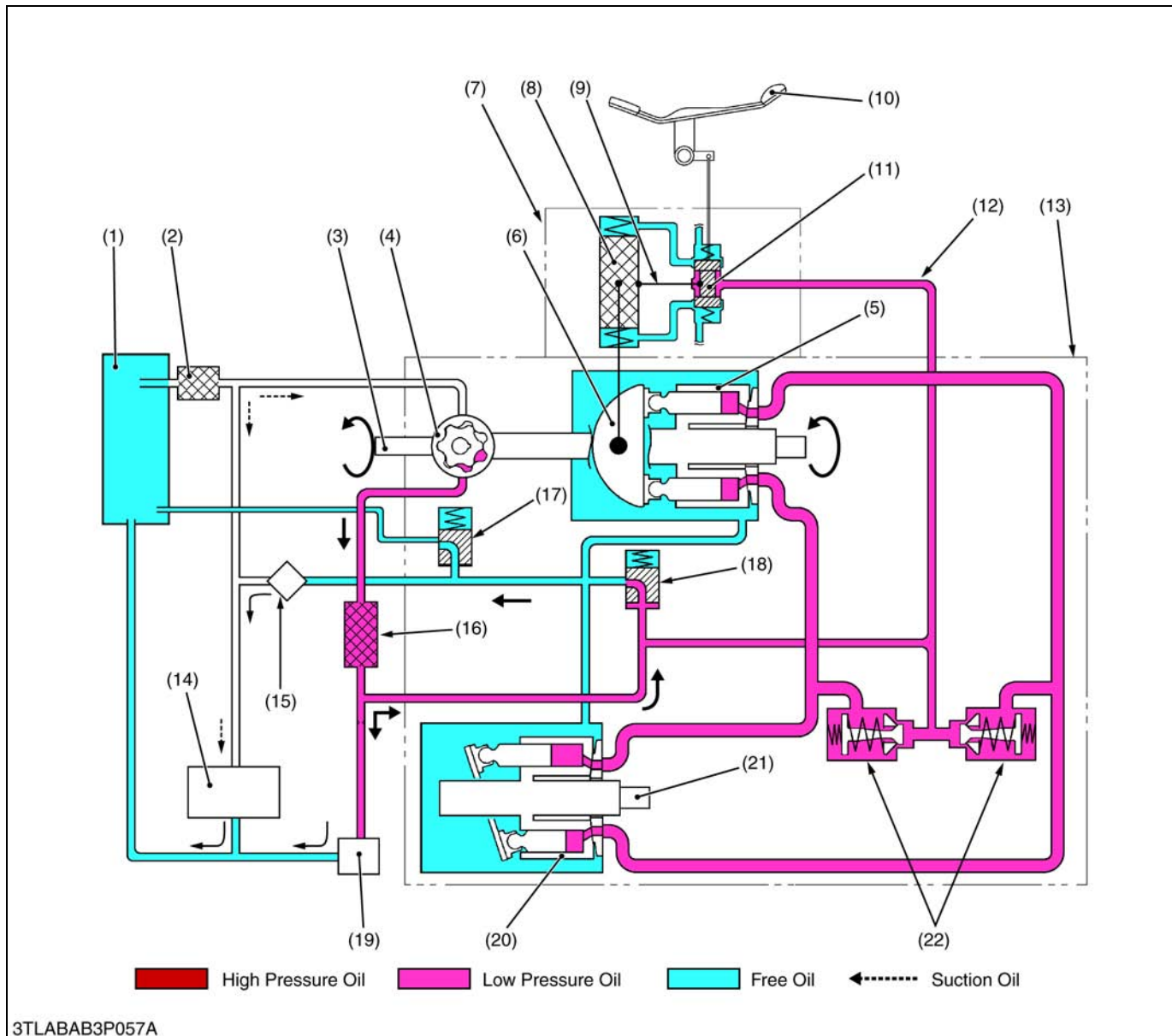

**(D) Operation****■ Neutral**

- |                         |                              |  |   |
|-------------------------|------------------------------|--|---|
| (1) Transmission Case   | (7) Regulator Valve Assembly | (13) HST Assembly                      | (18) Charge Relief Valve                  |
| (2) Filter              | (8) Servo Piston             | (14) Main Circuit and Steering Circuit | (19) PTO Clutch Valve Circuit             |
| (3) Input Shaft         | (9) Feedback Lever           | (15) Oil Cooler                        | (20) Motor Cylinder                       |
| (4) Charge Pump         | (10) HST Pedal               | (16) Filter                            | (21) Output Shaft                         |
| (5) Pump Cylinder       | (11) Regulator Valve         | (17) Case Relief Valve                 | (22) Check and High Pressure Relief Valve |
| (6) Variable Swashplate | (12) Bypass Pipe             |  |   |

The sucked oil from the transmission case (1) by the charge pump (4) flows into the HST housing (13) and regulator valve (7) through the oil filter (16) and charge relief valve (18). Overflow oil from HST housing (13) flows to the suction line through the oil cooler (15).

When the HST pedal (10) is in neutral, regulator valve (7) is not activated, so the variable swashplate (6) is at right angle to the pump pistons and they only rotate with cylinder (5) without reciprocation. Since the oil is not being pumped to motor, the cylinder block in the motor (20) is stationary and the output shaft (21) does not rotate.

## ■ Forward

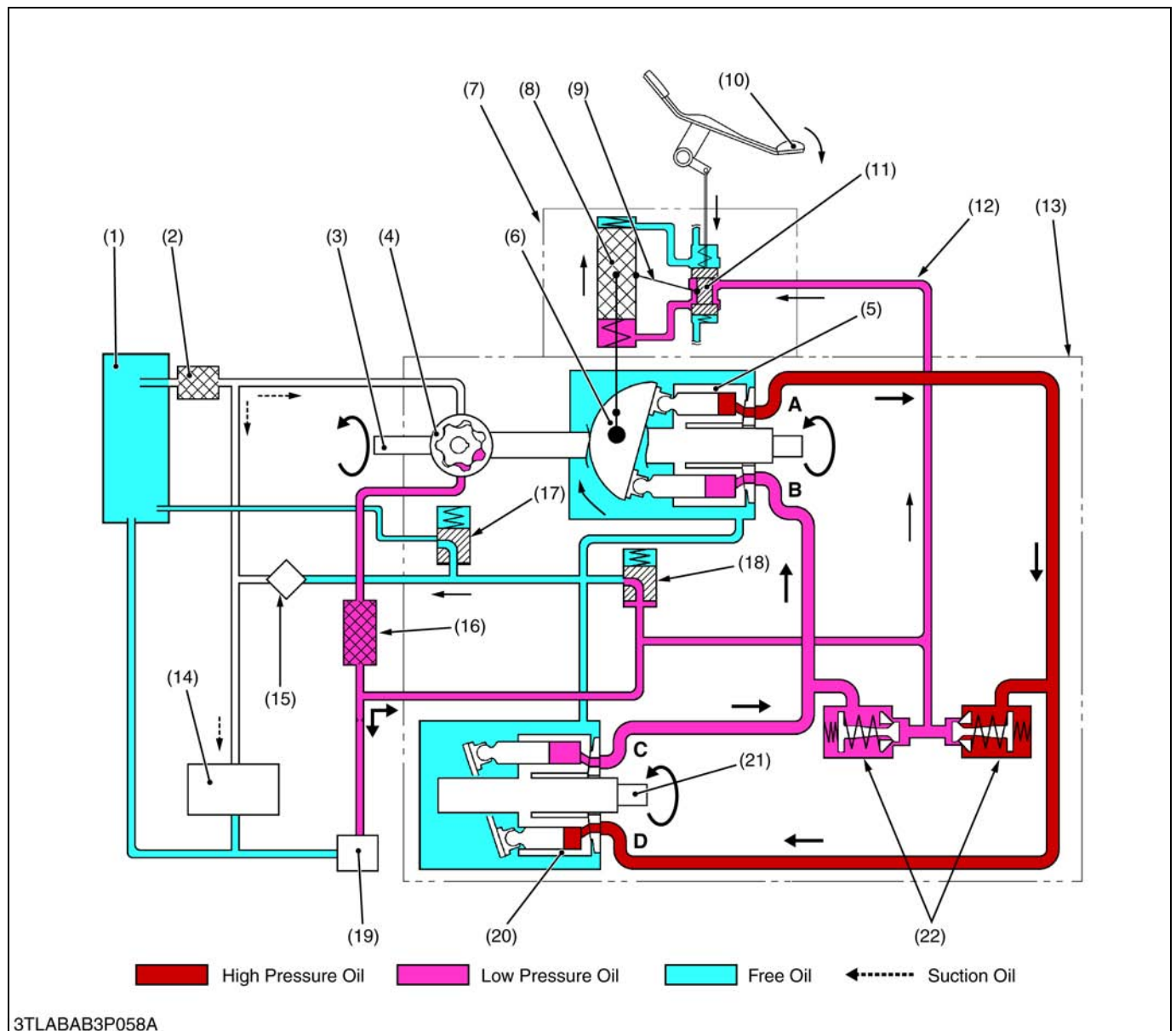

- |                              |  |   |                         |
|------------------------------|--|---|-------------------------|
| (1) Transmission Case        | (9) Feedback Lever                     | (16) Filter                               | <b>A : Pump Port A</b>  |
| (2) Filter                   | (10) HST Pedal                         | (17) Case Relief Valve                    | <b>B : Pump Port B</b>  |
| (3) Input Shaft              | (11) Regulator Valve                   | (18) Charge Relief Valve                  | <b>C : Motor Port C</b> |
| (4) Charge Pump              | (12) Bypass Pipe                       | (19) PTO Clutch Valve Circuit             | <b>D : Motor Port D</b> |
| (5) Pump Cylinder            | (13) HST Assembly                      | (20) Motor Cylinder                       |                         |
| (6) Variable Swashplate      | (14) Main Circuit and Steering Circuit | (21) Output Shaft                         |                         |
| (7) Regulator Valve Assembly | (15) Oil Cooler                        | (22) Check and High Pressure Relief Valve |                         |
| (8) Servo Piston             |  |   |                         |

When the HST pedal (10) is stepped on and in forward, so the variable swashplate (6) is tilted by the servo piston (8) and regulator valve (11) as shown in figure above.

As the pump cylinder block (5) rotates with the input shaft (3), oil is forced out of pump port **A** at high pressure. As pressure oil enters motor port **D**, the pistons, which align with port **D**, are pushed against the thrust plate and slide down inclined surface.

Then the output shaft (21) rotates with the motor cylinder block (20). This drives the machine forward and the angle of pump swashplate determines the output shaft speed.

As the motor cylinder block continues to rotate, oil is forced out of motor port **C** at low pressure and returns to the pump port **B**.

## ■ Reverse

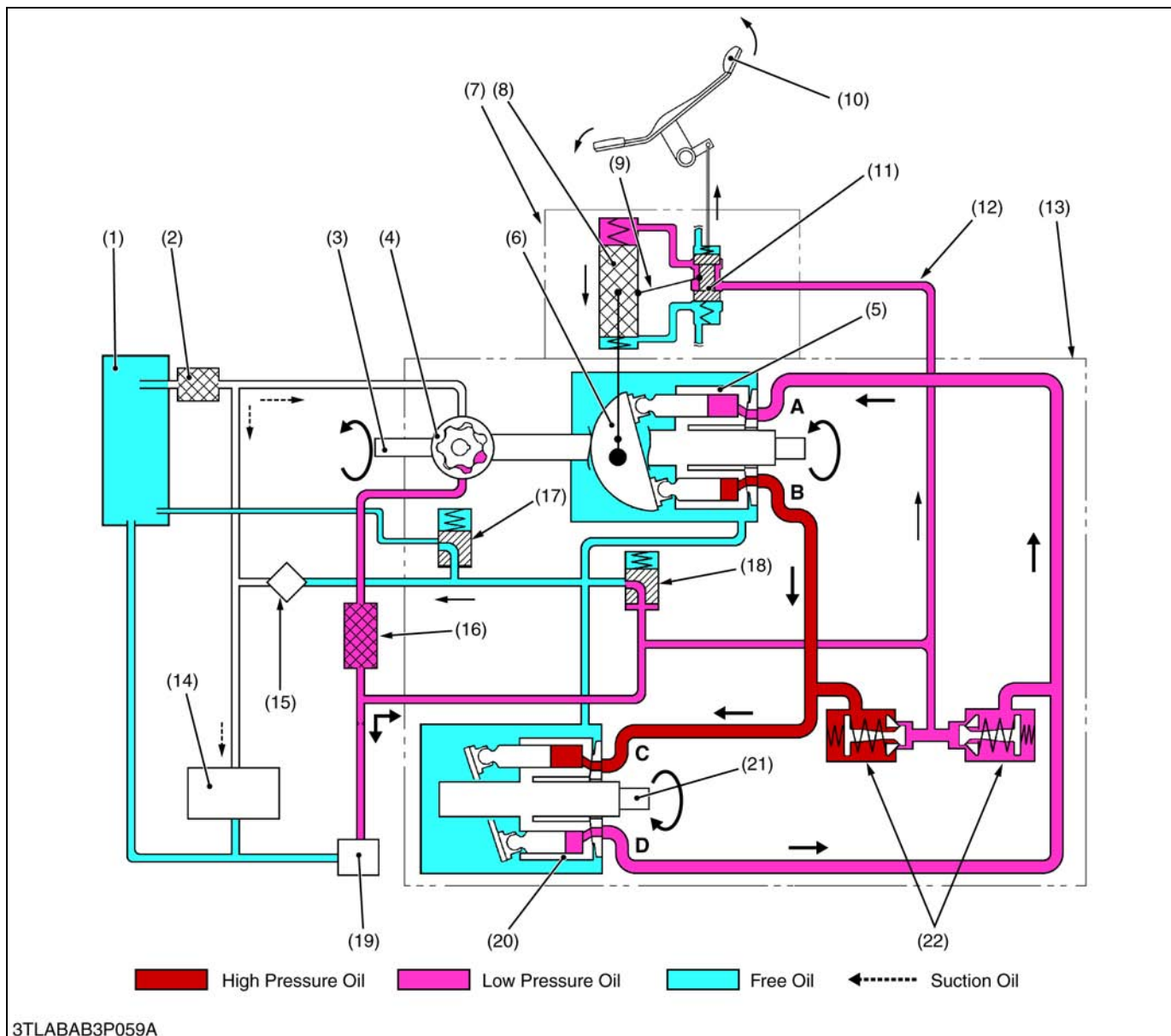

- |                              |  |   |                         |
|------------------------------|--|---|-------------------------|
| (1) Transmission Case        | (9) Feedback Lever                     | (16) Filter                               | <b>A : Pump Port A</b>  |
| (2) Filter                   | (10) HST Pedal                         | (17) Case Relief Valve                    | <b>B : Pump Port B</b>  |
| (3) Input Shaft              | (11) Regulator Valve                   | (18) Charge Relief Valve                  | <b>C : Motor Port C</b> |
| (4) Charge Pump              | (12) Bypass Pipe                       | (19) PTO Clutch Valve Circuit             | <b>D : Motor Port D</b> |
| (5) Pump Cylinder            | (13) HST Assembly                      | (20) Motor Cylinder                       |                         |
| (6) Variable Swashplate      | (14) Main Circuit and Steering Circuit | (21) Output Shaft                         |                         |
| (7) Regulator Valve Assembly | (15) Oil Cooler                        | (22) Check and High Pressure Relief Valve |                         |
| (8) Servo Piston             |  |   |                         |

When the HST pedal (10) is stepped on and in reverse, the variable swashplate (6) is tilted by servo piston (8) and regulator valve (11) as shown in figure above.

As the pump cylinder block (5) rotates with the input shaft (3), oil is forced out of pump port **B** at high pressure. As pressure oil enters motor port **C**, the pistons, which align with port **C**, are pushed against the thrust plate and slide down inclined surface.

Then the output shaft (21) rotates with the motor cylinder block (20). This drives the machine rearward and the angle of pump swashplate determines the output shaft speed.

As the motor cylinder block continues to rotate, oil is forced out of motor port **D** at low pressure and returns to the pump port **A**.

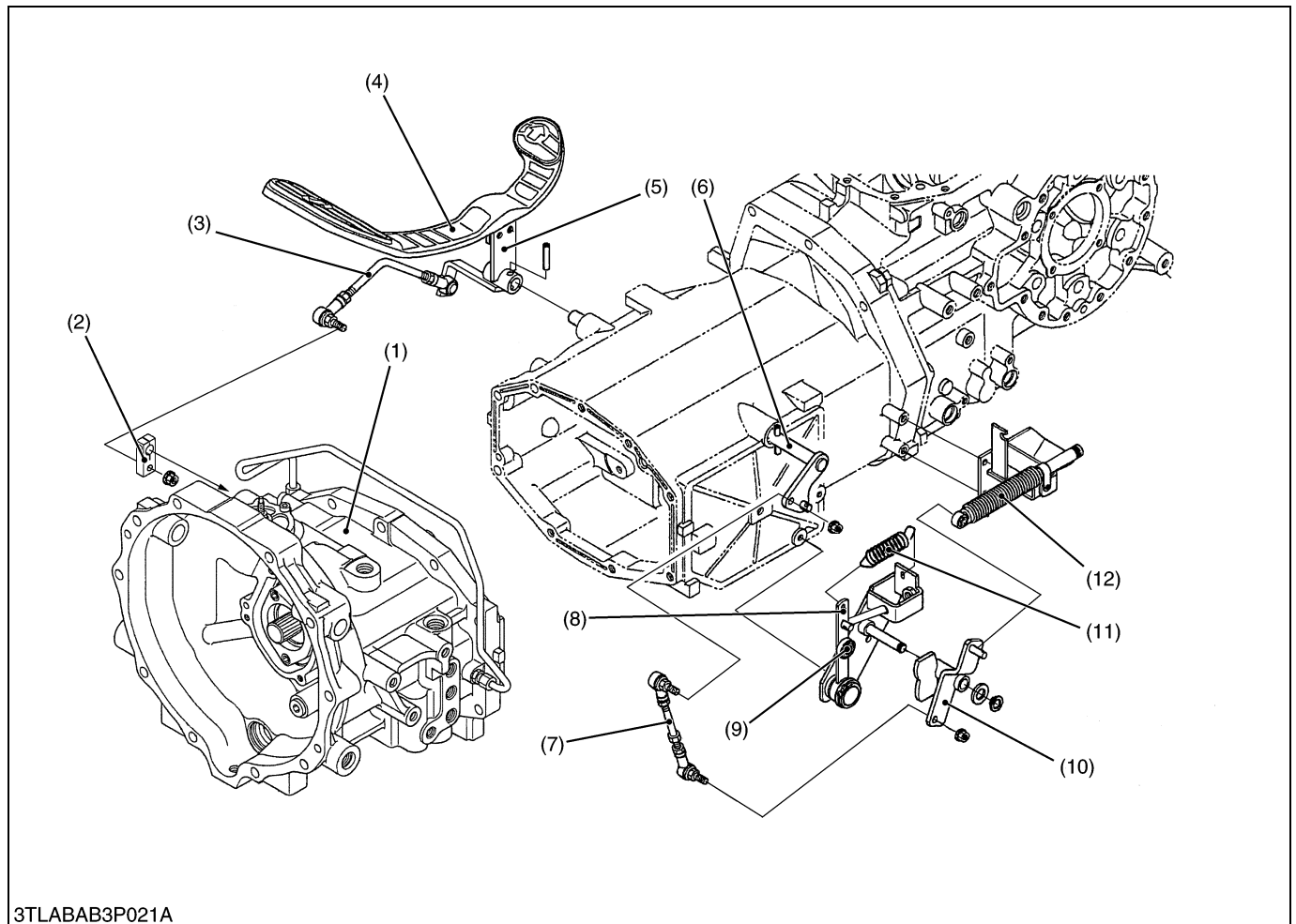
**(E) Control Linkage**

- |                       |                      |                    |                         |
|-----------------------|----------------------|--------------------|-------------------------|
| (1) HST Assembly      | (4) HST Pedal        | (7) Neutral Rod    | (10) Neutral Holder Arm |
| (2) HST Control Lever | (5) Pedal Bracket    | (8) Neutral Holder | (11) Neutral Spring     |
| (3) HST Control Rod   | (6) Connecting Shaft | (9) Ball Bearing   | (12) Damper             |

The speed control pedal (HST pedal) (4) and the HST control lever (servo control lever) (2) are linked with the pedal bracket (5) and HST control rod (3). And HST pedal (4) and the neutral holder arm (10) are linked with pedal bracket (5) and neutral rod (7) through connecting shaft (6).

As the HST pedal (4) is depressed to forward, the HST control lever (2) is rotated, then the swashplate is tilted by servomechanism and forward travelling speed increases. Then, the swashplate is returned to neutral with the neutral holder arm (10), when the pedal is released. The ball bearing (9) on the neutral holder (8) pulled with the neutral spring (11) seats the detent of the neutral holder arm (10) so that the neutral holder arm returns to neutral.

The damper (12) is connected to the HST pedal (4) through connecting shaft (6), neutral rod (7) and neutral holder arm (10), restricts the movement of the linkage to prevent abrupt operation or reversing.

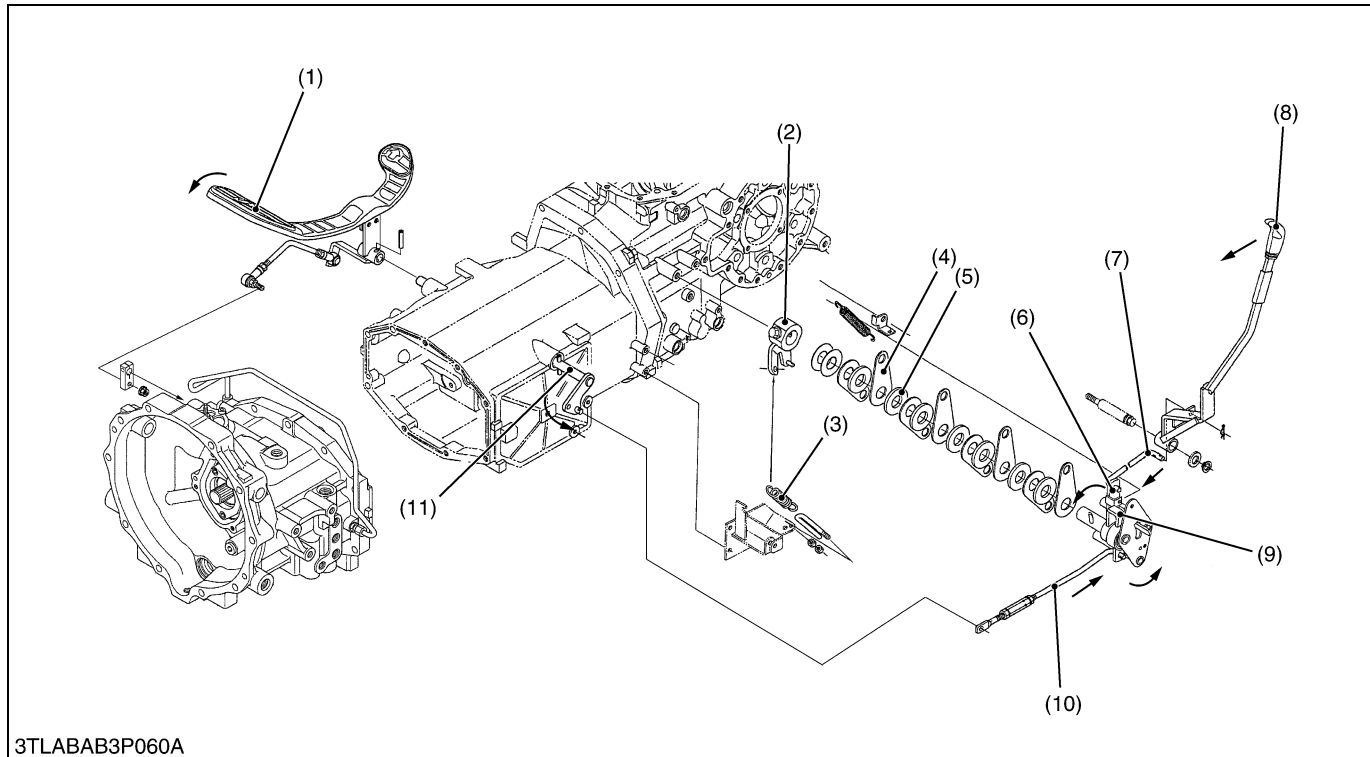
**(F) Cruise Control****■ Speed Set**

- |                   |                    |                          |                           |
|-------------------|--------------------|--------------------------|---------------------------|
| (1) HST Pedal     | (4) Plate          | (7) Lever Rod            | (10) Cruise Adjusting Rod |
| (2) Release Lever | (5) Rubber         | (8) Cruise Control Lever | (11) Connecting Shaft     |
| (3) Cruise Spring | (6) Cruise Lever 2 | (9) Cruise Lever 1       |                           |

The cruise control lever (8) and HST pedal (1) are linked with the lever rod (7), cruise lever 1 (9), cruise lever 2 (6), cruise adjusting rod (10) and connecting shaft (11).

When the cruise control lever (8) is moved to forward direction, cruise lever 2 (6) is moved to arrow direction by the lever rod (7). The cruise lever 1 (9) is moved forward by being pushed to the cruise lever 2 (6), and cruise adjusting rod (10) is pulled backward. Because cruise adjusting rod (10) and the HST pedal (1) are connected by the connecting shaft (11), the HST pedal is moved and HST becomes forward position.

On the other hand, because the plate (4) and the rubber (5) are suppressed outside by the release lever (2) and the cruise spring (3), cruise lever 1 (9) and cruise lever 2 (6) are fixed at the position. As a result, cruise control lever position can be infinitely set.

In addition, because the movement of the cruise lever 1 (9) is restricted by the cruise lever 2 (6), the backward pedal operation cannot be done while the cruise control lever (8) is operating.

## ■ Release

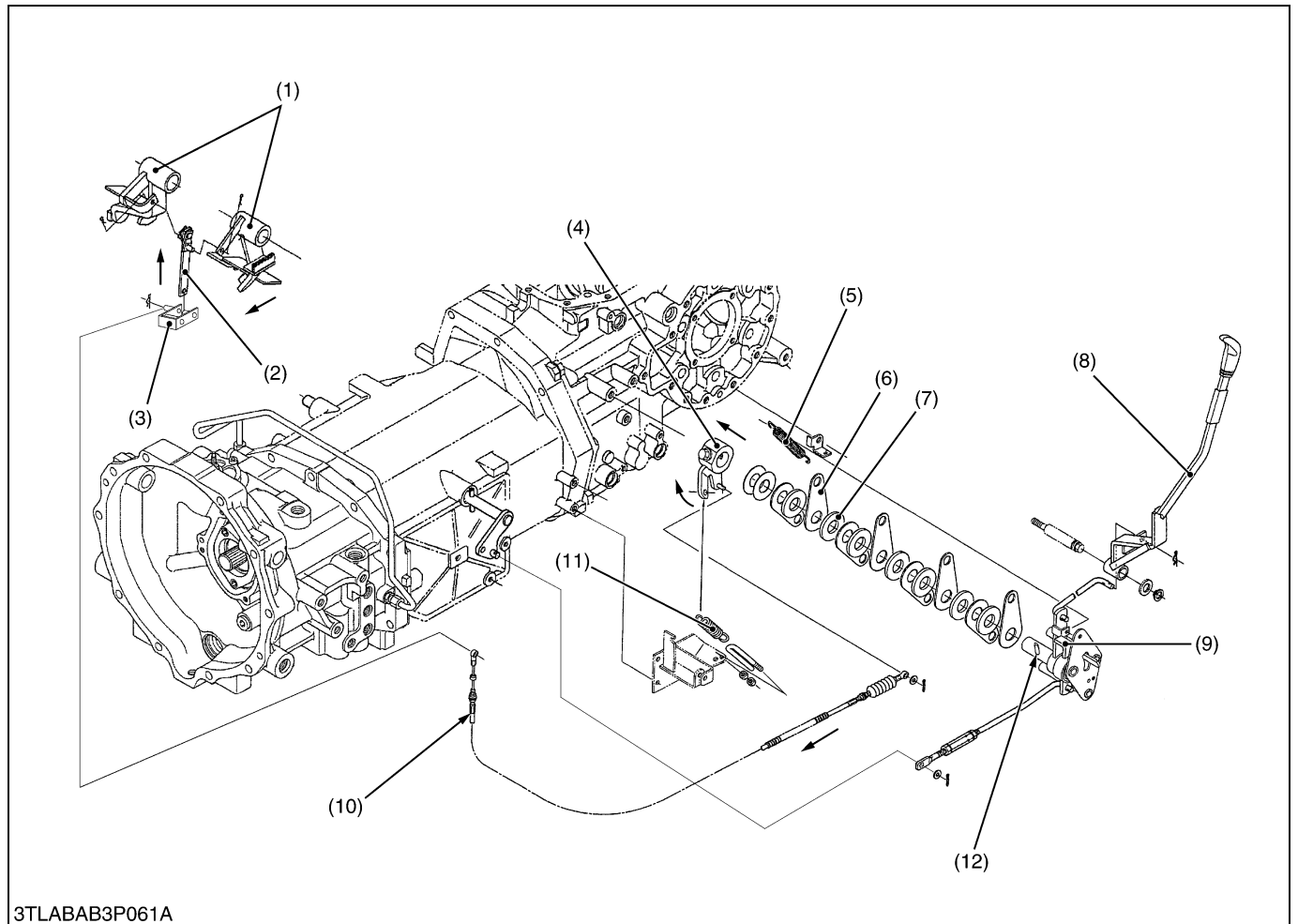

- |                 |                    |                          |                    |
|-----------------|--------------------|--------------------------|--------------------|
| (1) Brake Pedal | (4) Release Lever  | (7) Rubber               | (10) Release Wire  |
| (2) Brake Lever | (5) Release Spring | (8) Cruise Control Lever | (11) Cruise Spring |
| (3) Bracket     | (6) Plate          | (9) Cruise Lever 2       | (12) Groove        |

The cruise control can be returned to neutral automatically when brake pedals (1) are depressed.

The cruise control lever (8) is set with plates (6) and rubbers (7) by the release lever (4) and cruise spring (11). When brake pedals (1) are depressed, brake lever (2) to pull the release lever (4) via release wire (10). The release lever (4) is moved along grooves (12).

As a result, the holding force of cruise control lever (8) is lost and the cruise control lever (8) returns to neutrality by force of the release spring (5).

### ■ NOTE

- The cruise control will release when both brake pedals are depressed.
- The cruise control does not release when the individual right or left brake is applied.



## (2) Range Gear Shift Section

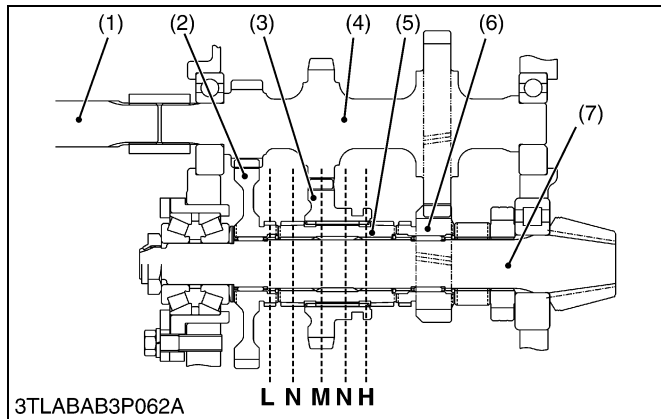

The range gear shift section is located in the differential gear case.

It changes the speed to five positions (**L**, **N**, **M**, **N** and **H**) by shifting of shifter gear (3) in the straight line on bevel pinion shaft (7).

- (1) Counter Shaft
- (2) Gear (for L)
- (3) Shifter Gear (for M)
- (4) Range Gear Shaft
- (5) Spline Boss
- (6) Gear (for H)
- (7) Spiral Bevel Pinion Shaft

**L** : Low Speed Position  
**N** : Neutral Position  
**M** : Middle Speed Position  
**H** : High Speed Position

W1024698

## (3) Front Wheel Drive Section

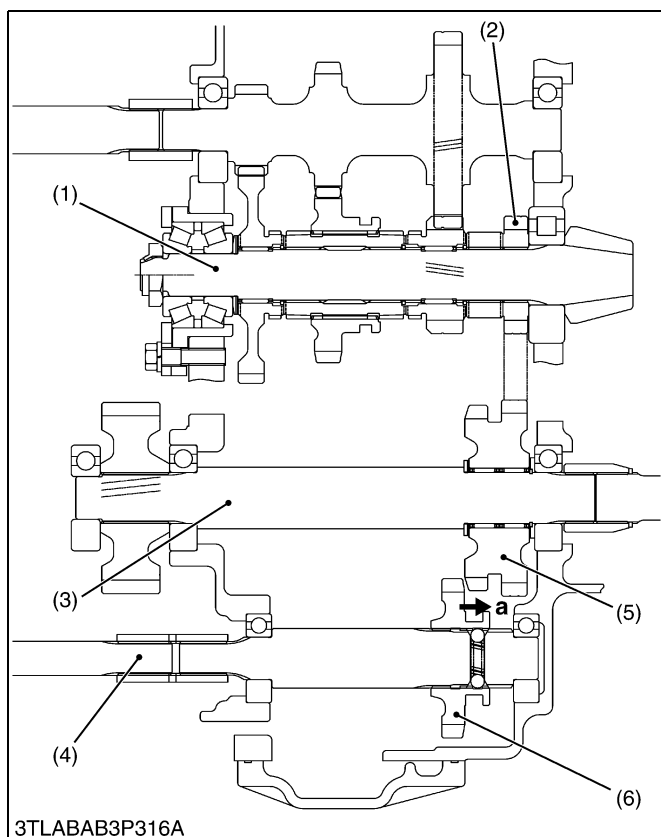

Front wheel drive section is located in the differential gear case.

2 wheel drive or 4 wheel drive is selected by operating the front wheel drive lever to shift the shifter gear (6).

- (1) Spiral Bevel Pinion Shaft
- (2) Front Wheel Drive Output Gear
- (3) PTO Drive Shaft
- (4) Front Wheel Drive Shaft
- (5) Front Wheel Drive Gear
- (6) Shifter Gear

**a** : 4 Wheel Drive Position

W1024918



### [3] SHIFT LINKAGE MECHANISM

The shift linkage mechanism of "Front Wheel Drive Lever", refer to page 3-M6.

#### (1) Range Gear Shift Lever

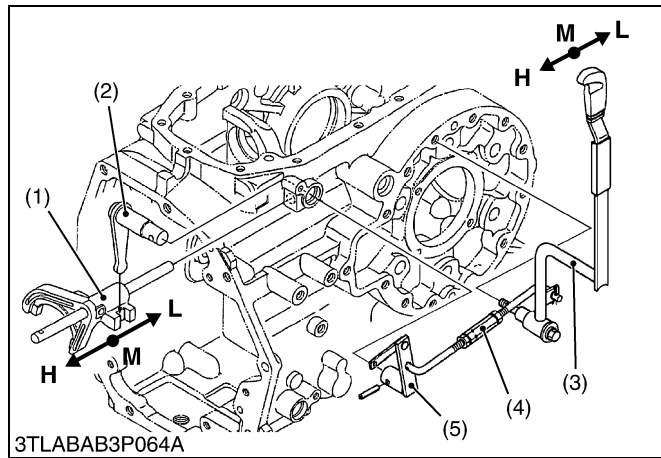

The links are connected from the shift lever (3) to the shift fork (1) as shown in figure.

- |                            |                         |
|----------------------------|-------------------------|
| (1) Shift Fork             | <b>H : High Speed</b>   |
| (2) Shift Arm              | <b>M : Middle Speed</b> |
| (3) Range Gear Shift Lever | <b>L : Low Speed</b>    |
| (4) Rod                    |                         |
| (5) Sub-arm                |                         |

W1025045

## 4. PTO SYSTEM

### [1] STRUCTURE

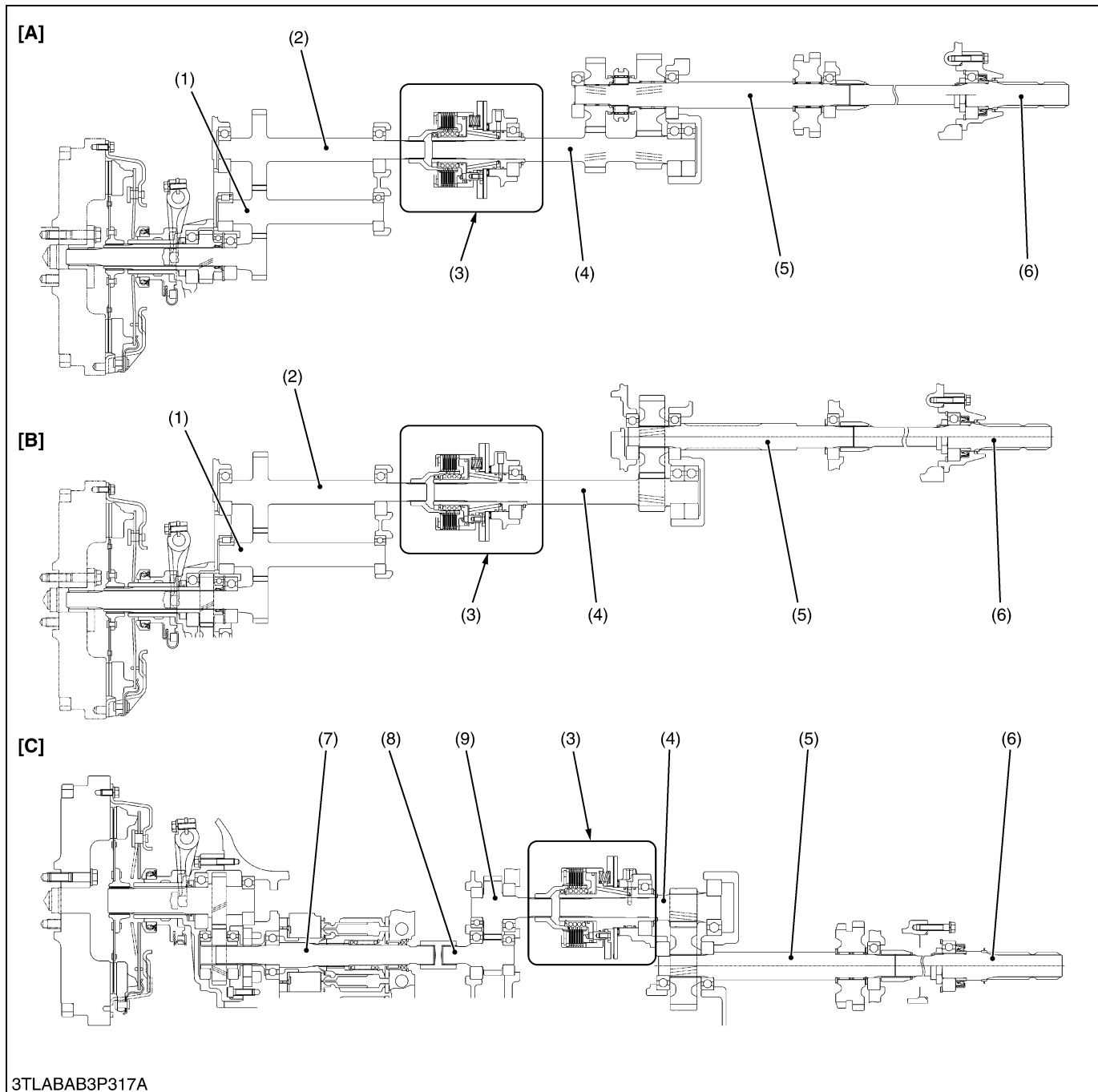

- (1) PTO Gear Shaft 1
- (2) PTO Gear Shaft 2
- (3) PTO Clutch Pack

- (4) PTO Counter Shaft
- (5) PTO Drive Shaft
- (6) PTO Shaft

- (7) Output Shaft (Motor Shaft)
- (8) PTO Gear Shaft 1
- (9) PTO Gear Shaft 2

- [A] Manual Transmission Model**
- [B] GST Model**
- [C] HST Model**

The independent PTO operated by hydraulic clutch (3) is adapted for all models. PTO is “**ENGAGED**” or “**DISENGAGED**” by operating the shift lever of the PTO clutch valve.

The power train from the clutch to the PTO shaft is composed as shown in figure above.

### (Reference)

- PTO speed of each model is as shown in the table below.

### Manual Transmission and GST Model

Rear PTO	L	All Model	540 min <sup>-1</sup> (rpm) at 2550 min <sup>-1</sup> (rpm) engine speed
	H	L3130, L3430, L3830, L4630	750 min <sup>-1</sup> (rpm) at 2550 min <sup>-1</sup> (rpm) engine speed

### HST Model

Rear PTO	L3130, L3430, L3830, L4630	540 min <sup>-1</sup> (rpm) at 2640 min <sup>-1</sup> (rpm) engine speed
	L5030	540 min <sup>-1</sup> (rpm) at 2660 min <sup>-1</sup> (rpm) engine speed

## [2] PTO CLUTCH

### (1) Shift Linkage

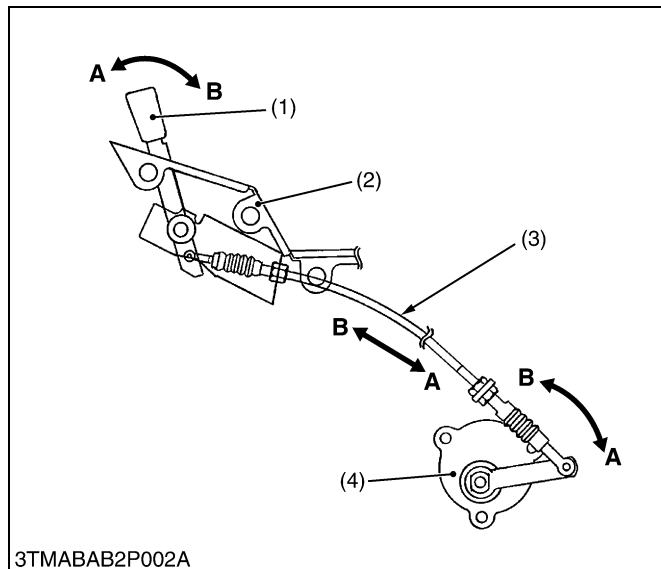

The shift lever (1) and the PTO clutch valve (4) are connected by the shift cable (3) as shown in the left figure.

When the shift lever is moved to the **B** side, the PTO clutch valve (4) is set at “**ENGAGED**” position. Then the oil flows to clutch pack through the PTO clutch valve (4), and the clutch pack is engaged and the PTO shaft rotates. When the shift lever is moved to the **A** side, the PTO clutch valve (4) is set at the “**DISENGAGED**” position.

- |                 |                      |
|-----------------|----------------------|
| (1) Shift Lever | (3) Shift Cable      |
| (2) Lever Guide | (4) PTO Clutch Valve |

W1025261

### (2) Oil Flow

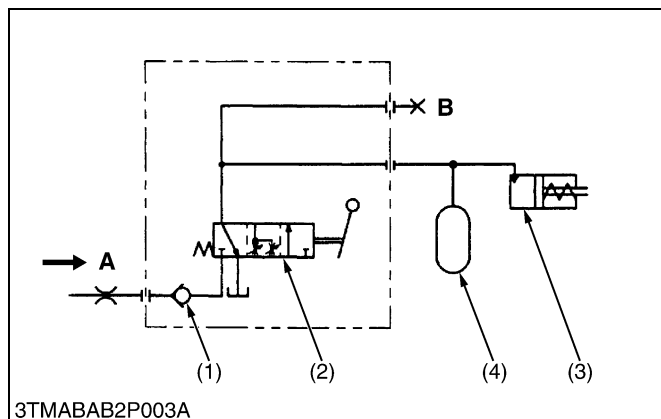

Oil flows into the clutch valve (2) after it is regulated to the system pressure. As for the system pressure of the PTO clutch valve, it is controlled by the regulating valve for GST and Manual Transmission model, and it is controlled by the HST charge relief valve for HST model. When the PTO lever is at the “**DISENGAGED**” position, the oil does not flow through the PTO clutch valve (2) to the clutch pack. When the PTO lever is at the “**ENGAGED**” position, the oil flows through the PTO clutch valve (2) to the accumulator (4) and the PTO clutch pack (3) to engage it.

- |                                       |  |
|---------------------------------------|--|
| (1) Check Valve<br>(Except HST Model) | <b>A</b> : From Regulating Valve (For<br>Manual Transmission and<br>GST Model) |
| (2) PTO Clutch Valve                  | <b>From HST Charge Pump<br/>(For HST Model)</b>                                |
| (3) PTO Clutch Pack                   | <b>B</b> : Pressure Check Port   |
| (4) Accumulator                       |  |

W1025366

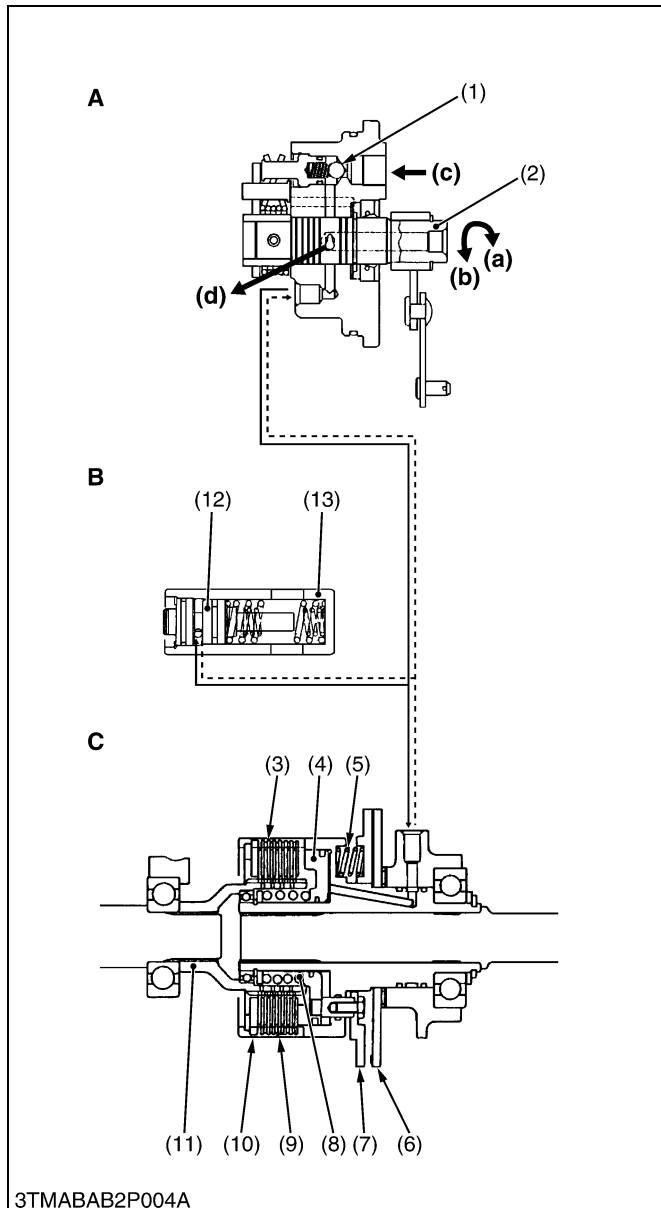
**(3) Operation**

The oil flows into the clutch valve and opens the check valve (1). When the shift lever is set at the “**ENGAGED**” position, the spool (2) is turned to (a) position, then the oil flows through the spool (2) into the accumulator and the clutch pack. Oil entering the clutch pack pushes the piston (4) to engage the clutch pack. The accumulator absorbs the engaging shock of the clutch pack.

When the shift lever is set at the “**DISENGAGED**” position, the spool (2) is turned to (b) position, then the oil is stopped by the spool (2) and the oil in the PTO clutch pack and accumulator is drained into the transmission case. Thus the piston (4) is pushed back, the brake plate (7) is also moved to contact the brake disc (6) so as to stop the rotation and the drag of the PTO shaft.

- (1) Check Valve  
(Except HST Model)
- (2) Spool
- (3) Plate
- (4) Piston
- (5) Brake Spring
- (6) Brake Disc
- (7) Brake Plate
- (8) Return Spring
- (9) Clutch Disc
- (10) Back Plate
- (11) Clutch Hub
- (12) Accumulator Piston
- (13) Bearing Case

- (a) **ENGAGED** Position
- (b) **DISENGAGED** Position
- (c) From Regulator Valve or  
HST Charge Pump
- (d) Drain (To the Transmission  
Case)
- A : PTO Clutch Valve**
- B : Accumulator**
- C : PTO Clutch Pack**

W1025465

## [3] GROUND PTO (IF EQUIPPED)

### (1) Power Train

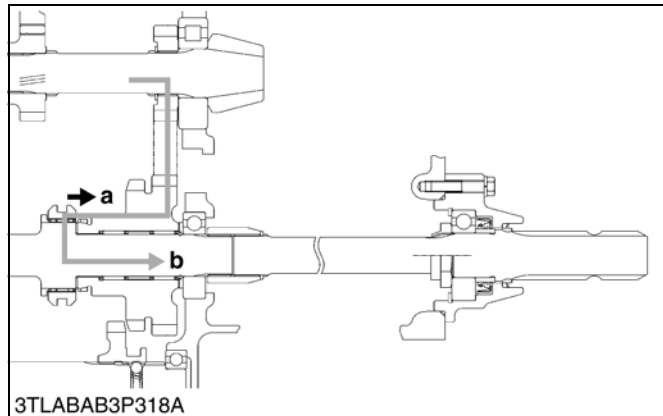

The ground PTO gear section is located in the mid case, and it use constant mesh. It is shifted by the ground PTO shift lever to shift the shifter. The power train of ground PTO is as shown in figure.

Then the PTO shaft is turned an amount proportional to the tractor travelling speed.

a : Ground PTO Position      b : PTO Speed

W1022245

### (2) Shift Linkage

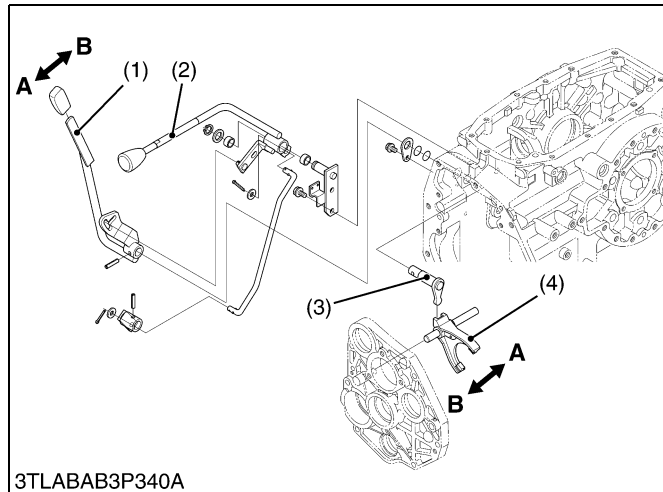

The ground PTO can be engage only when PTO speed change lever is in the neutral position.

The ground PTO lever (1) is connected directly to the shift fork (4). When the ground PTO lever (1) is moved to the **A** side, the shift fork (4) is also moved to **A** side, then the ground PTO is "**Engaged**". When the ground PTO lever (1) is moved to the **B** side, the ground PTO is "**Disengaged**".

(1) Ground PTO Lever      (3) Shift Arm  
(2) PTO Speed Change Lever      (4) Shift Fork

W1022300

## [4] TWO STAGE PTO (IF EQUIPPED)

### (1) Power Train

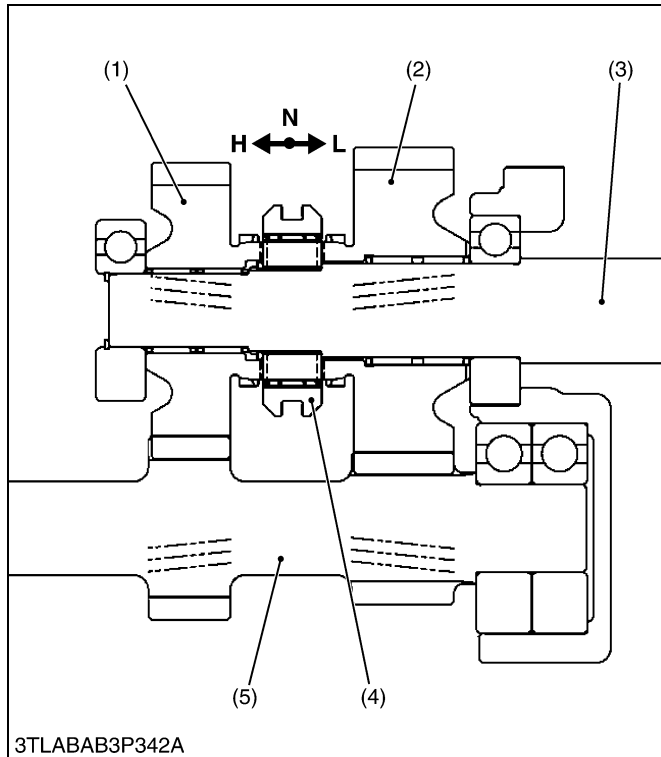

The two stage PTO gear section is located in the mid case, and it uses constant mesh.

- |                       |                             |
|-----------------------|-----------------------------|
| (1) Gear for High     | <b>L : Lo-speed Shift</b>   |
| (2) Gear for Low      | <b>N : Neutral Position</b> |
| (3) PTO Drive Shaft   | <b>H : Hi-speed Shift</b>   |
| (4) Shifter           |                             |
| (5) PTO Counter Shaft |                             |

W1022635

### (2) Shift Linkage

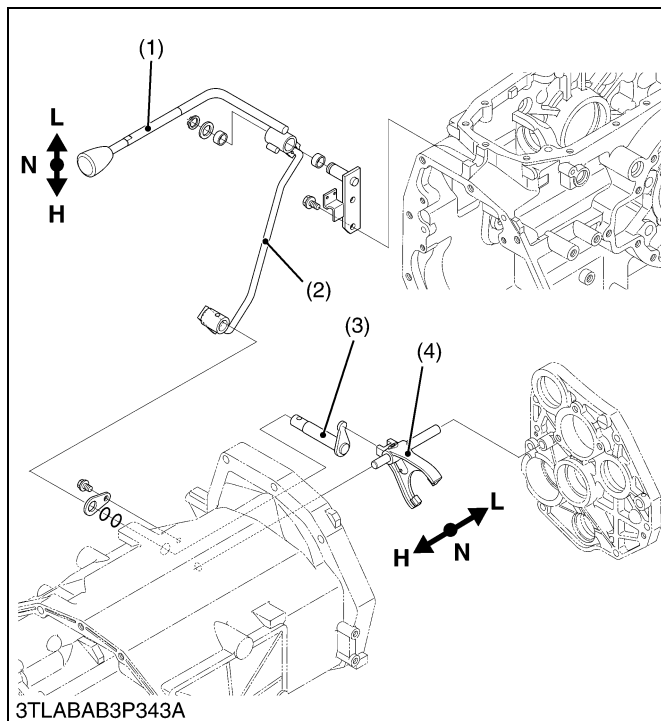

The links from the PTO speed change lever (1) to the shift fork (4) are connected as shown in the figure.

When the PTO speed change lever (1) is moved to L side, the shift fork (4) is moved to the L side by means of the rod (2) to the Lo-speed side. When the PTO speed change lever (1) is moved to the H side, the shift fork (4) is moved to the Hi-speed side.

- |                            |                             |
|----------------------------|-----------------------------|
| (1) PTO Speed CHange Lever | <b>L : Lo-speed Shift</b>   |
| (2) Rod                    | <b>N : Neutral Position</b> |
| (3) Shift Arm              | <b>H : Hi-speed Shift</b>   |
| (4) Shift Fork             |                             |

W1022707

# SERVICING

## CONTENTS

1. TROUBLESHOOTING .....	3-S1
[1] GENERAL .....	3-S1
[2] GST SYSTEM .....	3-S2
[3] HST SYSTEM .....	3-S8
[4] PTO SYSTEM .....	3-S10
2. SERVICING SPECIFICATIONS .....	3-S11
[1] GENERAL .....	3-S11
[2] PTO CLUTCH .....	3-S12
[3] GST .....	3-S13
[4] HST .....	3-S14
3. TIGHTENING TORQUES .....	3-S15
4. CHECKING, DISASSEMBLING AND SERVICING .....	3-S17
[1] MANUAL TRANSMISSION MODEL .....	3-S17
(1) Checking and Adjusting .....	3-S17
(2) Disassembling and Assembling .....	3-S18
(3) Servicing .....	3-S43
[2] GLIDE SHIFT TRANSMISSION (GST) MODEL .....	3-S49
(1) Checking and Adjusting .....	3-S49
(2) Disassembling and Assembling .....	3-S55
(3) Servicing .....	3-S84
[3] HYDROSTATIC TRANSMISSION (HST) MODEL .....	3-S86
(1) Checking and Adjusting .....	3-S86
(2) Disassembling and Assembling .....	3-S92
(3) Servicing .....	3-S115



# 1. TROUBLESHOOTING

## [1] GENERAL

Symptom	Probable Cause	Solution	Reference Page
<b>Excessive Transmission Noise</b>	<ul style="list-style-type: none"> <li>Transmission fluid insufficient</li> <li>Gear worn or backlash improper</li> <li>Bearing worn or broken</li> <li>Shift fork worn</li> <li>Spline worn</li> <li>Snap rings on the shaft come off</li> <li>Spiral bevel pinion lock nut improperly tightened</li> <li>Improper backlash between spiral bevel pinion and spiral bevel gear</li> <li>Improper backlash between differential pinion and differential side gear</li> </ul>	Replenish Replace  Replace Replace Replace Repair or replace Tighten  Adjust  Adjust	G-7, 8 3-S46 to S48 3-S43 3-S43 3-S43 – 3-S36  3-S46  3-S47
<b>Gear Slip Out of Mesh</b>	<ul style="list-style-type: none"> <li>Shift linkages rusted</li> <li>Shifter or shift fork worn or damaged</li> <li>Shift fork interlock ball spring weaken or damaged</li> <li>Interlock ball fallen</li> <li>Synchronizer unit damaged</li> <li>Gears worn or broken</li> </ul>	Repair Replace Replace  Reassemble Replace Replace	– – 3-S27, S63  3-S27, S63 3-S44 –
<b>Hard Shifting</b>	<ul style="list-style-type: none"> <li>Shifter or shift fork worn or damaged</li> <li>Shift fork bent</li> <li>Shift linkage rusted</li> <li>Shaft part of shift arms rusted</li> <li>Synchronizer unit damaged</li> </ul>	Replace Replace Repair Repair Replace	– – – – 3-S44
<b>Gears Clash When Shifting</b>	<ul style="list-style-type: none"> <li>Clutch does not release</li> <li>Gears worn or damaged</li> <li>Synchronizer unit damaged</li> </ul>	Adjust or repair Replace Replace	G-24 – 3-S44
<b>Differential Lock Can Not Be Set</b>	<ul style="list-style-type: none"> <li>Differential lock shift fork damaged</li> <li>Differential lock shift fork mounting clevis pin damaged</li> <li>Differential lock shifter pin bent or damaged</li> <li>Differential lock fork shaft bent or damaged</li> </ul>	Replace Replace  Replace Replace	3-S39 3-S39  3-S39 3-S39
<b>Differential Lock Pedal Does Not Return</b>	<ul style="list-style-type: none"> <li>Differential lock pedal return spring weaken or damaged</li> <li>Differential lock shifter pin bent or damaged</li> <li>Differential lock fork shaft bent</li> </ul>	Replace  Replace Replace	–  3-S39 3-S39
<b>Excessive or Unusual at All Time</b>	<ul style="list-style-type: none"> <li>Improper backlash between spiral bevel pinion and spiral bevel gear</li> <li>Improper backlash between differential pinion and differential side gear</li> <li>Bearings worn</li> <li>Insufficient or improper type of transmission fluid used</li> </ul>	Adjust  Adjust  Replace Replenish or replace	3-S46  3-S47  – G-7, 8
<b>Noise While Turning</b>	<ul style="list-style-type: none"> <li>Differential pinion or differential side gears worn or damaged</li> <li>Differential lock binding (does not disengage)</li> <li>Bearing worn</li> </ul>	Replace  Replace Replace	3-S42  3-S39 –

W1014322



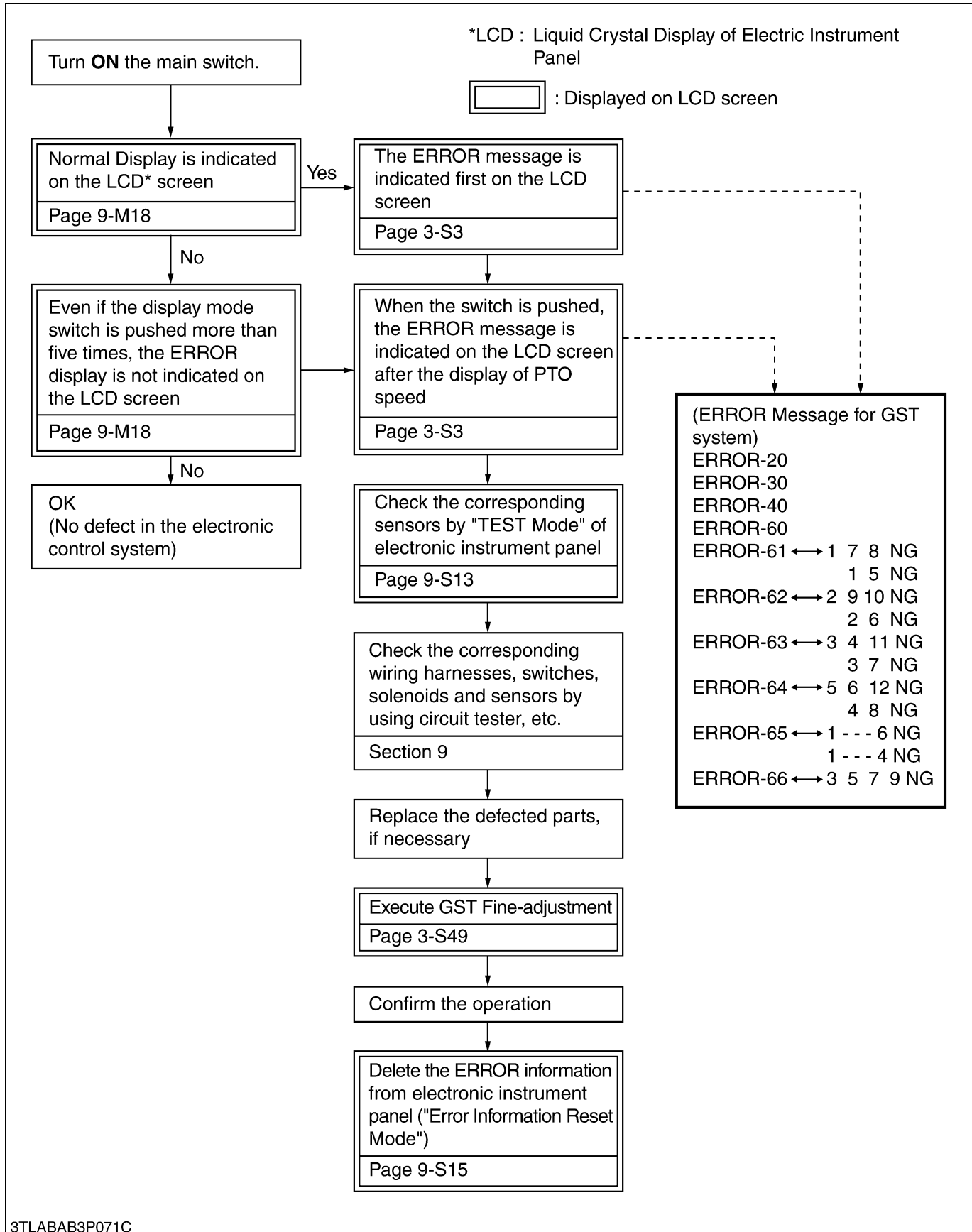

## [2] GST SYSTEM

### ■ Electrical Diagnosis by Electronic Instrument Panel (IntelliPanel)

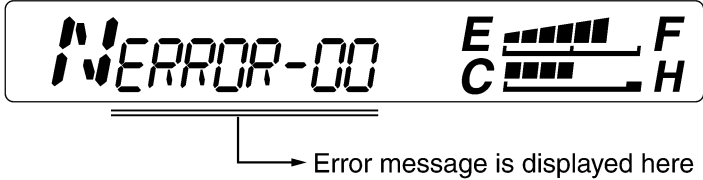
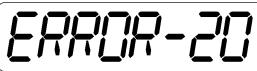

3TLABAB3P071C

## ■ Error Display

				
Display on LCD Screen	Trouble Item	Probable Cause	Solution	Reference Page
	Communication error between ECU and electronic instrument panel	<ul style="list-style-type: none"> <li>• Fuse blown out</li> <li>• Communication line between ECU and electronic instrument panel is broken or short-circuited</li> <li>• No signals from ECU for longer than 5 seconds (error cleared if signal sent and received later)</li> <li>• ECU defective</li> </ul>	<ul style="list-style-type: none"> <li>• Check fuse</li> <li>• Check ECU connector</li> <li>• Check communication line between ECU and electronic instrument panel at ECU connector</li> <li>• Replace ECU</li> </ul>	9-S27 9-S27  9-S31   9-S28
	ECU memory device has failed	<ul style="list-style-type: none"> <li>• ECU memory device failure</li> </ul>	<ul style="list-style-type: none"> <li>• Replace ECU</li> </ul>	9-S28
	Input voltage to lever sensor from ECU is failed	<ul style="list-style-type: none"> <li>• Lever sensor input voltage drop below 2.6 V for 0.1 second or more</li> <li>• Ground wire of lever sensor short-circuited</li> </ul>	<ul style="list-style-type: none"> <li>• Check ground wire</li> <li>• Check input voltage at ECU connector</li> <li>• Check sensor connector</li> </ul>	9-S27 9-S29  –
	GST lever sensor is failed	<ul style="list-style-type: none"> <li>• Lever sensor output terminal is out of adjustment</li> <li>• Lever sensor output wire terminal broken or short-circuited</li> <li>• Input line broken</li> <li>• Lever sensor defective</li> </ul>	<ul style="list-style-type: none"> <li>• It is possible to run at its selected speed position until engine is stopped.</li> <li>• Check sensor connector</li> <li>• Check sensor voltage by Test mode (Mode A)</li> <li>• Check lever sensor wire connector (voltage) or check sensor resistance</li> <li>• Replace lever sensor</li> </ul>	–  –  9-S13  9-S29, S31  9-M15
	Proportional reducing valve failure	<ul style="list-style-type: none"> <li>• Output voltage of proportional reducing valve terminal or return current is out of specification</li> <li>• Valve wire broken or short-circuited</li> <li>• Proportional reducing valve defective</li> </ul>	<ul style="list-style-type: none"> <li>• Check connector of proportional reducing valve</li> <li>• Check proportional reducing valve resistance at valve or ECU connector</li> <li>• Check grounding wire</li> <li>• Connect emergency connector and move</li> </ul>	–  9-S30, S32  9-S27  9-M17

W1013580

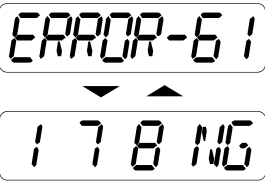
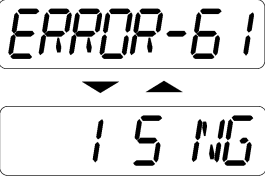
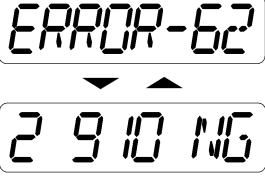
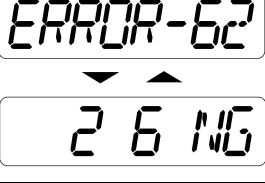
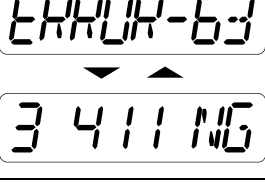
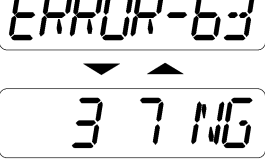
Display on LCD Screen	Trouble Item	Probable Cause	Solution	Reference Page
	Solenoid 1 failure (At forward or neutral)	<ul style="list-style-type: none"> <li>• Solenoid output terminal's voltage is out of specification</li> <li>• Solenoid broken or short-circuited</li> <li>• Wiring harness broken or short-circuited</li> <li>• Grounding plate of solenoid is poor contact with chassis</li> </ul>	<ul style="list-style-type: none"> <li>• Able to travel at speeds other than 1, 7 and 8 (Forward) or 1 and 5 (Reverse)</li> <li>• Check the wiring connector of solenoid</li> <li>• Check a resistance between solenoid and GND</li> <li>• Replace GST valve</li> </ul>	—
	Solenoid 1 failure (At reverse)			9-S30, S32 3-S79
	Solenoid 2 failure (At forward or neutral)			—
	Solenoid 2 failure (At reverse)			9-S30, S32 3-S79
	Solenoid 3 failure (At forward or neutral)			—
	Solenoid 3 failure (At reverse)			9-S30, S32 3-S79

W1011845

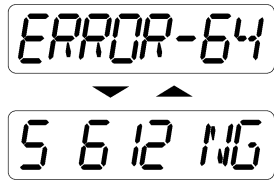
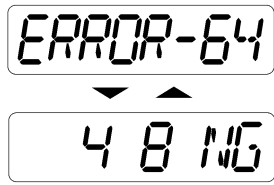
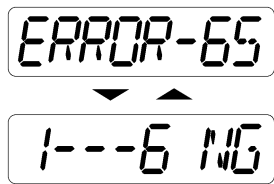
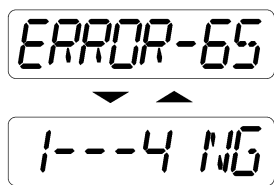
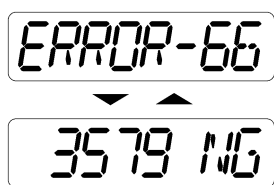
Display on LCD Screen	Trouble Item	Probable Cause	Solution	Reference Page
	Solenoid 4 failure (At forward or neutral)	<ul style="list-style-type: none"> <li>• Solenoid output terminal's voltage is out of specification</li> <li>• Solenoid broken or short-circuited</li> <li>• Wiring harness broken or short-circuited</li> <li>• Grounding plate of solenoid is poor contact with chassis</li> </ul>	<ul style="list-style-type: none"> <li>• Able to travel at speeds other than 5, 6 and 12 (Forward) or 4 and 8 (Reverse)</li> <li>• Check the wiring connector of solenoid</li> <li>• Check a resistance between solenoid and GND</li> <li>• Replace GST valve</li> </ul>	–
	Solenoid 4 failure (At reverse)			–
	Solenoid 6 (Main range gear shift) failure (At forward or neutral)			–
	Solenoid 6 (Main range gear shift) failure (At reverse)			–
	Solenoid 5 (Sub-range gear shift) failure			–
			<ul style="list-style-type: none"> <li>• Able to travel at speeds other than 3, 5, 7 and 9 (Forward)</li> <li>• Check the wiring connector of solenoid</li> <li>• Check a resistance between solenoid and GND</li> <li>• Replace GST valve</li> </ul>	–

W1087197

■ Error Message Does not Indicate on LCD

1. The tractor does not move while shifted.

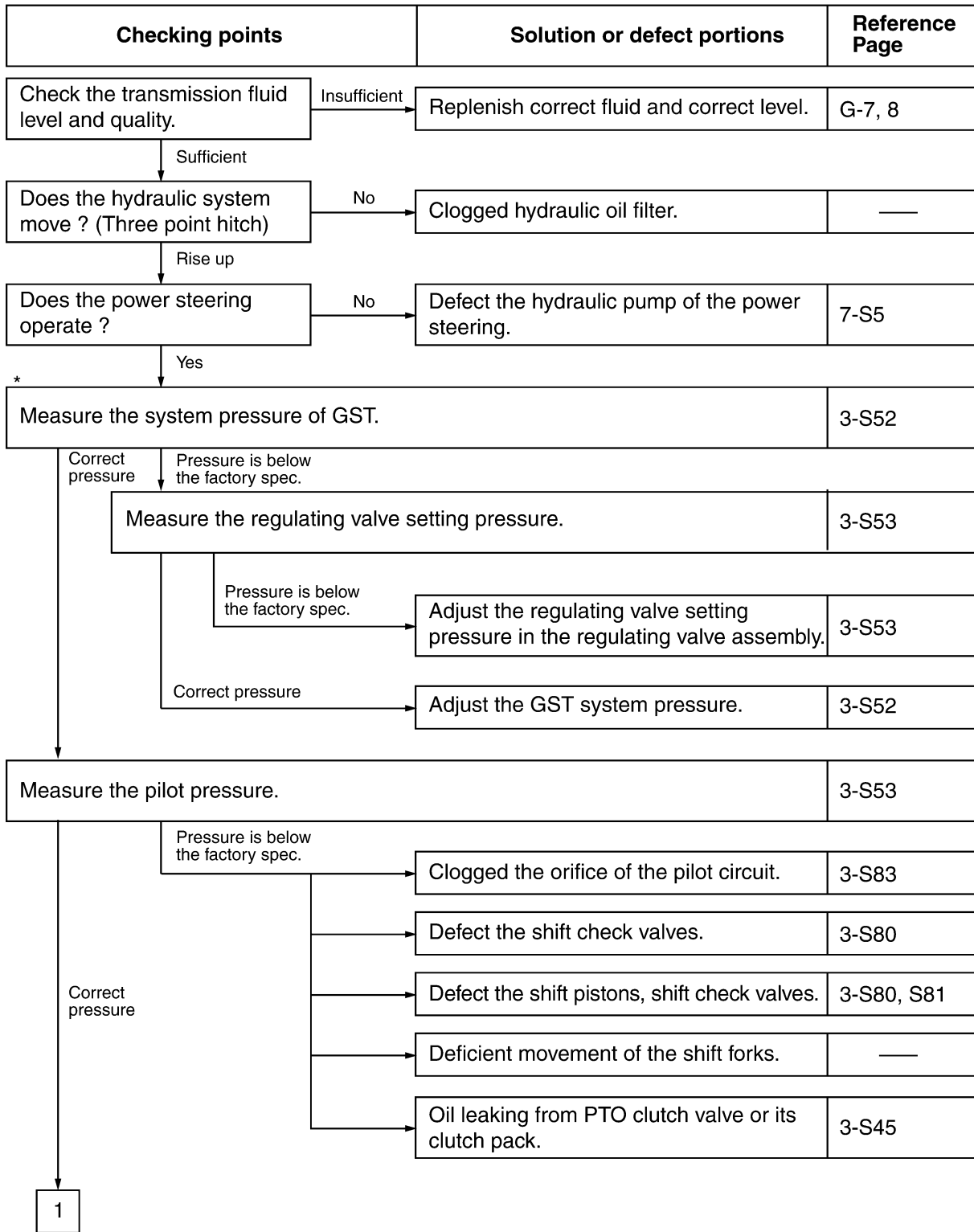

3TLABAB3P089B

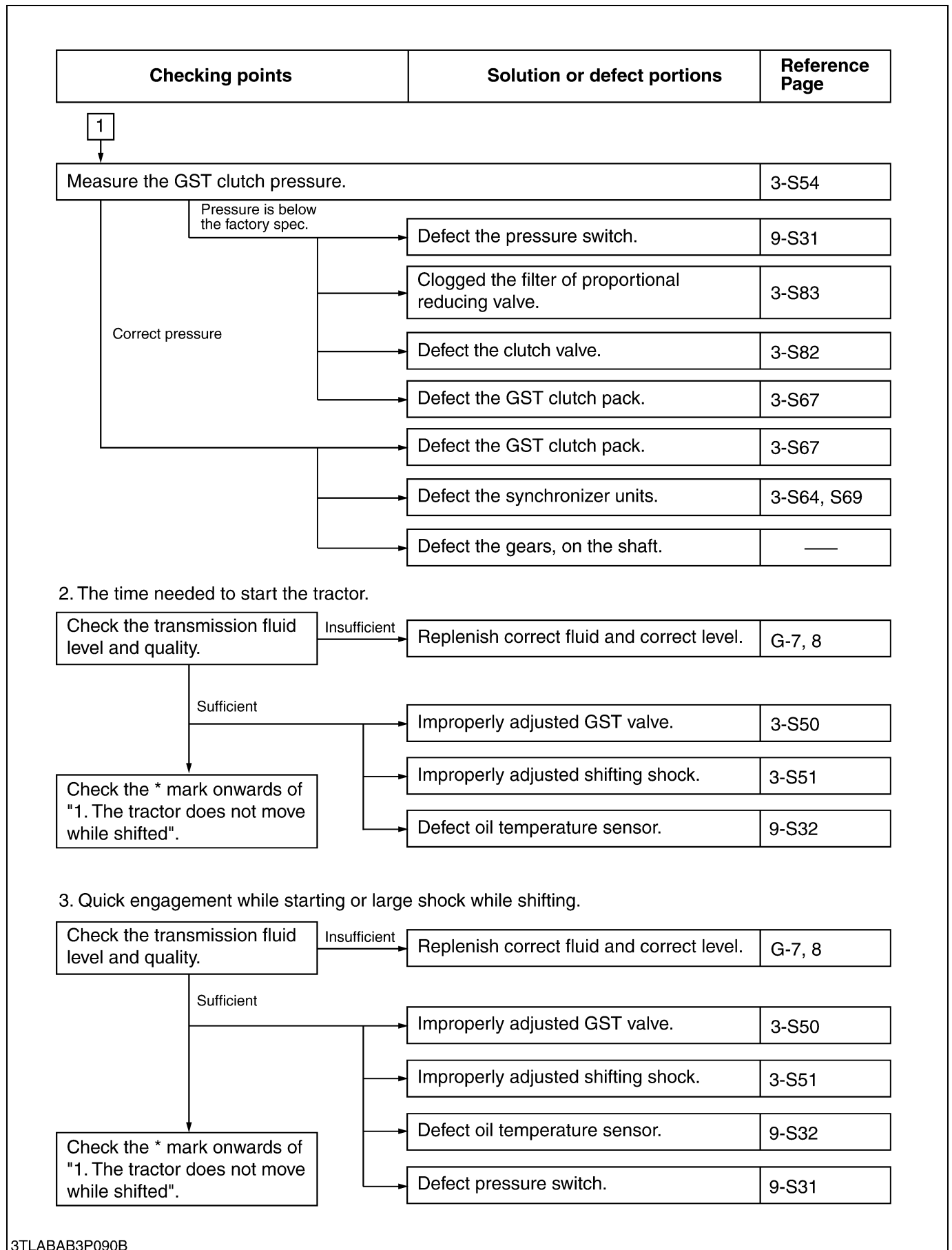

3TLABAB3P090B



### [3] HST SYSTEM

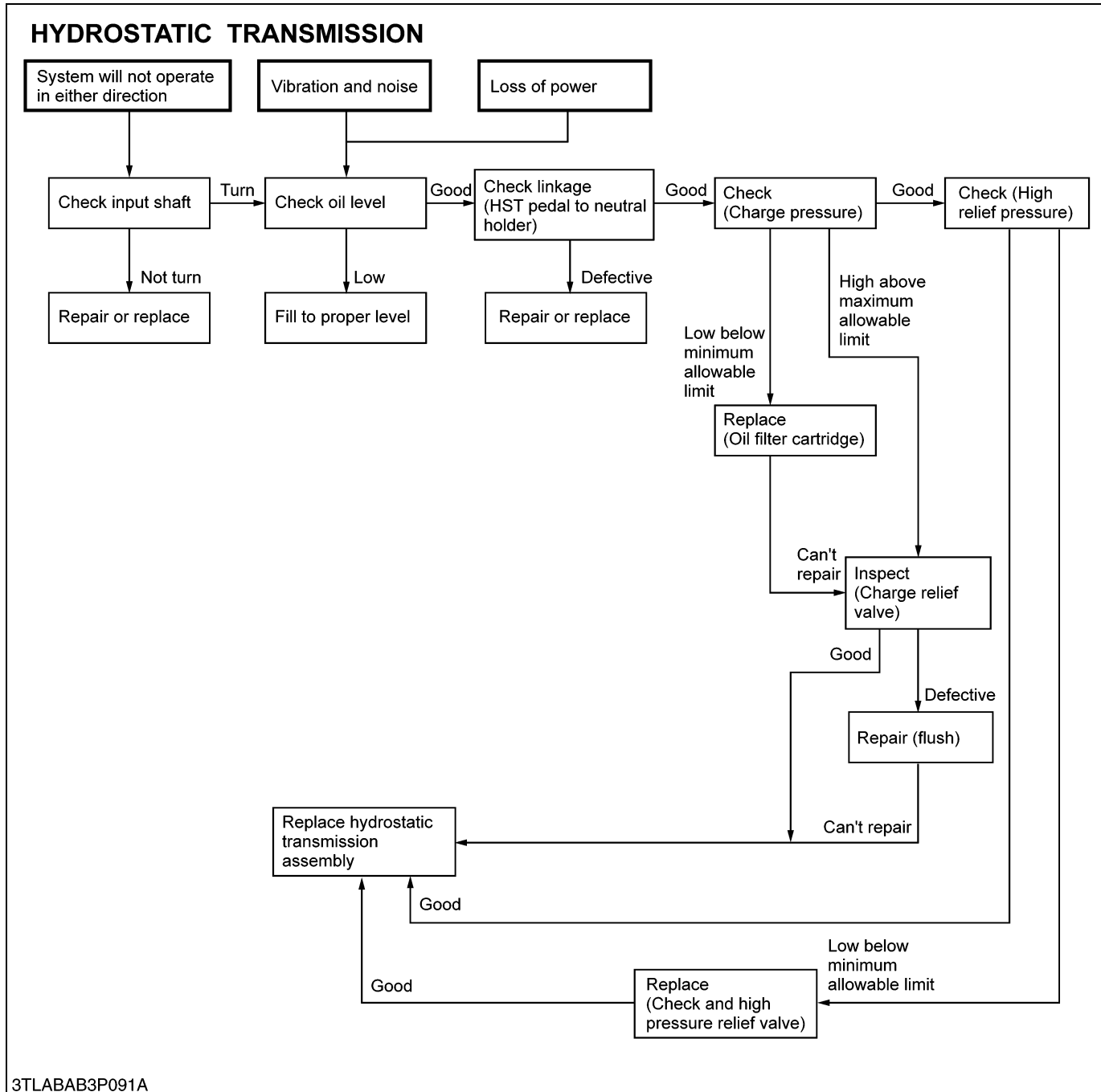

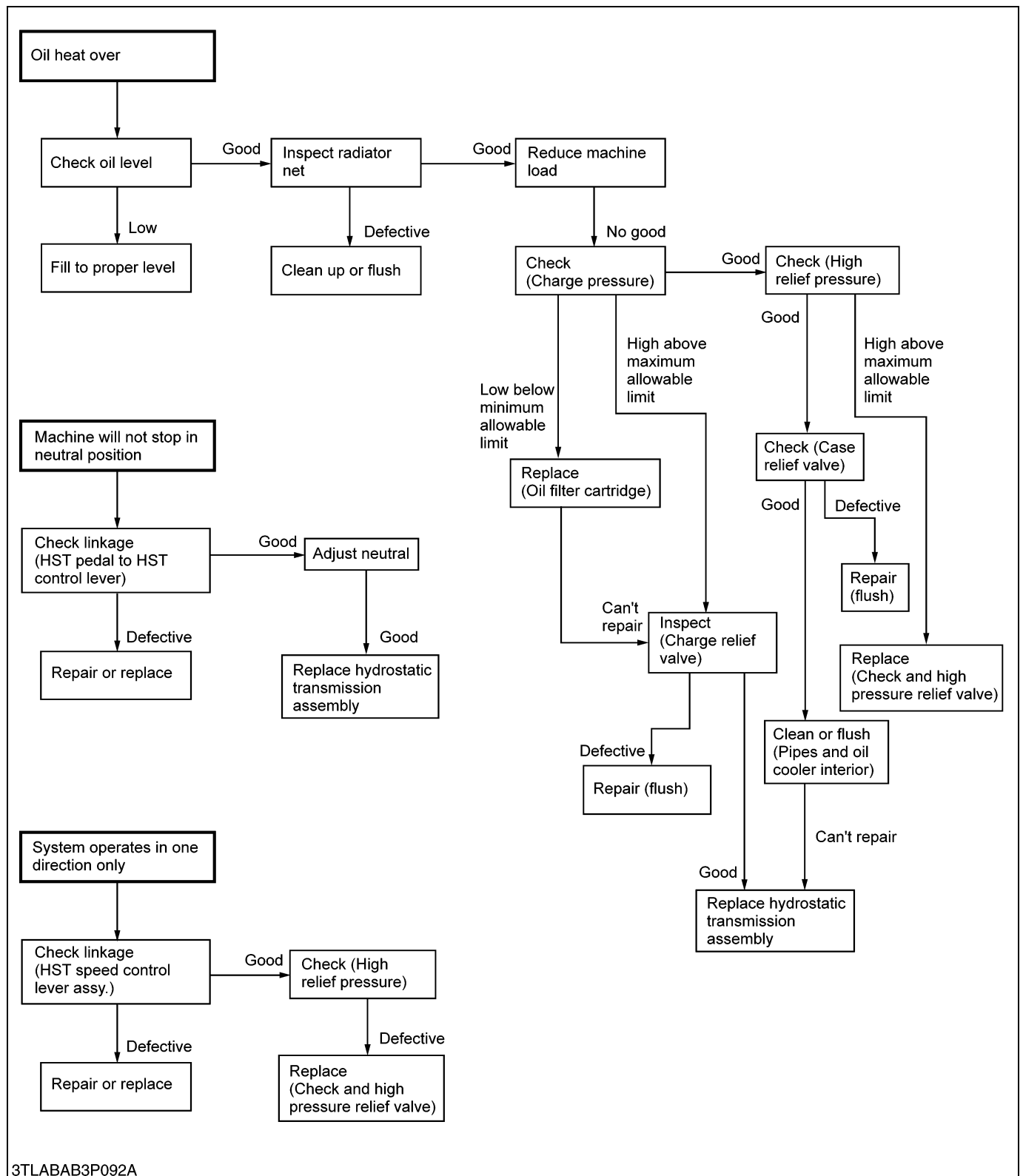

**[4] PTO SYSTEM****PTO CLUTCH**

<b>Symptom</b>	<b>Probable Cause</b>	<b>Solution</b>	<b>Reference Page</b>
<b>PTO Clutch Slip</b>	<ul style="list-style-type: none"> <li>• Operating pressure is low</li> <li>• PTO clutch valve malfunctioning</li> <li>• Clutch disc or drive plate excessively worn</li> <li>• Deformation of piston or return plate</li> </ul>	Adjust Repair or replace Replace Replace	3-S17, S89 3-S30 3-S32 3-S33
<b>PTO Shaft Does Not Rotate</b>	<ul style="list-style-type: none"> <li>• PTO clutch malfunctioning</li> <li>• PTO propeller shaft coupling disengaged</li> </ul>	Repair or replace Engage	3-S32 –
<b>PTO Clutch Operating Pressure is Low</b>	<ul style="list-style-type: none"> <li>• Transmission oil improper or insufficient</li> <li>• Relief valve malfunctioning</li> </ul>	Replenish or change Adjust or replace	G-7, 8 3-S17, S89
<b>PTO Clutch Drags</b>	<ul style="list-style-type: none"> <li>• Brake plate excessively worn</li> <li>• Return spring weaken or broken</li> <li>• Accumulator valve malfunctioning</li> <li>• Deformation or return plate or steal plate</li> </ul>	Replace Replace Repair or replace Replace	3-S33 3-S33 3-S32 3-S33

W10137180

## 2. SERVICING SPECIFICATIONS

### [1] GENERAL

Item		Factory Specification	Allowable Limit
Gear to Spline	Clearance	0.030 to 0.078 mm 0.00118 to 0.00307 in.	0.2 mm 0.008 in.
Shift Fork to Shifter Gear Groove	Clearance	0.20 to 0.40 mm 0.008 to 0.016 in.	0.8 mm 0.031 in.
Gear to Shaft	Clearance	0.021 to 0.054 mm 0.00083 to 0.00213 in.	0.1 mm 0.004 in.
Shift Fork to Shifter Groove	Clearance (Shuttle)	0.20 to 0.45 mm 0.0079 to 0.0177 in.	0.8 mm 0.031 in.
	(Others)	0.15 to 0.40 mm 0.0059 to 0.0157 in.	0.8 mm 0.031 in.
Synchronizer Ring to Gear (In Contact)	Side Clearance	–	0.35 mm 0.0138 in.
Spiral Bevel Gear	Turning Torque	3.92 to 6.37 N·m 0.40 to 0.65 kgf·m 2.89 to 4.70 ft-lbs	
Spiral Bevel Pinion to Spiral Bevel Gear	Backlash	0.15 to 0.30 mm 0.006 to 0.012 in.	–
	Tooth Contact	–	More than 35 %
	Center to Tooth Contact	–	1/3 to 1/2 of the entire width from the small end
Differential Case Bore (Differential Case Cover Bore) to Differential Side Gear Boss	Clearance	0.050 to 0.151 mm 0.00197 to 0.00594 in.	0.35 mm 0.0138 in.
Differential Case Bore	I.D.	40.500 to 40.550 mm 1.59449 to 1.59646 in.	–
Differential Case Cover Bore	I.D.	40.500 to 40.550 mm 1.59449 to 1.59646	–
Differential Side Gear Boss	O.D.	40.338 to 40.450 mm 1.59008 to 1.59252 in.	–
Differential Pinion Shaft to Differential Pinion	Clearance	0.060 to 0.102 mm 0.00236 to 0.00402 in.	0.25 mm 0.0098 in.
Differential Pinion Shaft	O.D.	19.959 to 19.980 mm 0.78579 to 0.78661 in.	–
Differential Pinion	I.D.	20.040 to 20.061 mm 0.78898 to 0.78980 in.	–

W1013874

Item		Factory Specification	Allowable Limit
Differential Pinion to Differential Side Gear	Backlash	0.15 to 0.30 mm 0.006 to 0.012 in.	0.40 mm 0.016 in.
Differential Side Gear Washer 1	Thickness	1.5 mm 0.059 in.	–
Differential Side Gear Washer 2	Thickness	1.6 mm 0.063 in.	–
Differential Side Gear Washer 3	Thickness	1.7 mm 0.067 in.	–

W1013874

## [2] PTO CLUTCH

PTO Clutch Valve Condition <ul style="list-style-type: none"> <li>• Engine Speed : Idling</li> <li>• Oil Temperature : 40 to 60 °C 104 to 140 °F</li> </ul>	Operating Pressure [Manual and GST Model]	2.30 to 2.50 MPa 23.5 to 25.5 kgf/cm <sup>2</sup> 334 to 363 psi	–
	[HST Model]	2.21 to 2.40 MPa 22.5 to 24.5 kgf/cm <sup>2</sup> 320 to 348 psi	–
PTO Clutch Disc	Thickness	1.70 to 1.90 mm 0.067 to 0.075 in.	1.55 mm 0.061 in.
PTO Steel Plate	Thickness	1.15 to 1.25 mm 0.045 to 0.049 in.	1.10 mm 0.043 in.
PTO Piston	Flatness	–	0.15 mm 0.006 in.
PTO Steel Plate	Flatness	–	0.30 mm 0.012 in.
PTO Return Spring	Free Length	40.5 mm 1.59 in.	37.5 mm 1.48 in.
PTO Brake Spring	Free Length	20.3 mm 0.80 in.	18.0 mm 0.71 in.
Seal Ring	Thickness	2.45 to 2.50 mm 0.096 to 0.098 in.	2.0 mm 0.079 in.

W1277262

**[3] GST**

Item		Factory Specification	Allowable Limit
GST System Pressure Condition	Setting Pressure	2.40 to 2.55 MPa 24.5 to 26.0 kgf/cm <sup>2</sup> 348 to 370 psi	–
<ul style="list-style-type: none"> <li>• Engine Speed : Idling</li> <li>• Oil Temperature : 40 to 60 °C 104 to 140 °F</li> </ul>			
Regulating Pressure Condition	Setting Pressure	2.74 to 2.94 MPa 28.0 to 30.0 kgf/cm <sup>2</sup> 398 to 427 psi	–
<ul style="list-style-type: none"> <li>• Engine Speed : Maximum</li> <li>• Oil Temperature : 40 to 60 °C 104 to 140 °F</li> </ul>			
GST Pilot Pressure Condition	Operating Pressure	2.30 to 2.50 MPa 23.5 to 25.5 kgf/cm <sup>2</sup> 334 to 363 psi	–
<ul style="list-style-type: none"> <li>• Engine Speed : Maximum</li> <li>• Oil Temperature : 40 to 60 °C 104 to 140 °F</li> <li>• GST Lever : 1st</li> <li>• Shuttle Lever : Forward or Reverse</li> </ul>			
GST Clutch Pressure Condition	Operating Pressure	2.30 to 2.50 MPa 23.5 to 25.5 kgf/cm <sup>2</sup> 334 to 363 psi	–
<ul style="list-style-type: none"> <li>• Engine Speed : Idling</li> <li>• Oil Temperature : 40 to 60 °C 104 to 140 °F</li> <li>• GST Lever : Neutral to 12th or 8th</li> <li>• Shuttle Lever : Neutral to Forward and Reverse</li> </ul>			
GST Clutch Disc	Thickness	2.55 to 2.65 mm 0.100 to 0.104 in.	2.50 mm 0.098 in.
GST Steel Plate	Thickness	1.55 to 1.65 mm 0.061 to 0.065 in.	1.50 mm 0.059 in.
GST Steel Plate	Flatness	–	0.30 mm 0.012 in.
GST Clutch Piston	Flatness	–	0.15 mm 0.006 in.
GST Clutch Piston Return Spring	Free Length	19.9 to 20.1 mm 0.78 to 0.79 in.	18.0 mm 0.71 in.
GST Clutch Seal Ring	Thickness	2.45 to 2.50 mm 0.096 to 0.098 in.	2.0 mm 0.079 in.

W1277262

**[4] HST**

Item		Factory Specification	Allowable Limit
Check and High Pressure Relief Valve Condition <ul style="list-style-type: none"> <li>• Engine Speed : Maximum</li> <li>• Oil Temperature : 40 to 60 °C 104 to 140 °F</li> <li>• Range Gear Shift Lever : H Position</li> <li>• HST Pedal : Depress Forward or Reverse with Brake</li> </ul>	Setting Pressure	33.3 to 36.3 MPa 340 to 370 kgf/cm <sup>2</sup> 4836 to 5262 psi	–
Charge Relief Valve Condition <ul style="list-style-type: none"> <li>• Engine Speed : Maximum</li> <li>• Oil Temperature : 40 to 60 °C 104 to 140 °F</li> <li>• HST Pedal : Neutral</li> </ul>	Setting Pressure	2.26 to 2.45 MPa 23 to 25 kgf/cm <sup>2</sup> 327 to 355 psi	–
Cruise Control Lever	Operating Force (Forward Direction)	54 to 64 N 5.5 to 6.5 kgf 12.1 to 14.3 lbs	–

W1277262



### 3. TIGHTENING TORQUES

Tightening torques of screws, bolts and nuts on the table below are especially specified.  
(For general use screws, bolts and nuts : See page G-10.)

Item	N·m	kgf·m	ft-lbs
(General)			
Lower frame mounting screw	260 to 304	26.5 to 31.0	192 to 224
ROPS lower connector mounting screw	103 to 118	10.5 to 12.0	75.9 to 86.8
ROPS plate mounting screw (M14 × 40)	138 to 147	14.0 to 15.0	102 to 108
(M14 × 30)	167 to 196	17.0 to 20.0	123 to 145
Step mounting bolt and nut	124 to 147	12.6 to 15.0	91.1 to 108
Floor seat mounting bolt and nut	196 to 225	20 to 23	145 to 166
Joint bolt for main delivery pipe 1 to front hydraulic block	49 to 69	5.0 to 7.0	36.1 to 50.6
Joint bolt for main delivery pipe 2 to rear hydraulic block	49 to 69	5.0 to 7.0	36.1 to 50.6
Cap nut for return pipe to mid case	49 to 69	5.0 to 7.0	36.1 to 50.6
Joint bolt for PTO delivery pipe	34 to 39	3.5 to 4.0	25.3 to 28.9
Engine and clutch housing mounting screw and nut	77.5 to 90.2	7.9 to 9.2	57.1 to 66.5
Engine and clutch housing mounting stud bolt	39.2 to 49.0	4.0 to 5.0	28.9 to 36.2
Clutch housing and mid case mounting nut	102.9 to 117.6	10.5 to 12.0	75.9 to 86.8
Clutch housing and mid case mounting screw	77.5 to 90.2	7.9 to 9.2	57.1 to 66.5
Clutch housing and mid case mounting stud bolt	38.2 to 45.1	3.9 to 4.6	28.2 to 33.3
Release fork mounting screw	23.5 to 27.5	2.4 to 2.8	17.4 to 20.3
Mid case and transmission case mounting screw	77.5 to 90.2	7.9 to 9.2	57.1 to 66.5
Mid case and transmission case mounting nut	102.9 to 117.6	10.5 to 12.0	75.9 to 86.8
Mid case and transmission case mounting stud bolt	39.2 to 49.0	4.0 to 5.0	28.9 to 36.2
PTO clutch valve mounting screw	23.5 to 27.4	2.4 to 2.8	17.4 to 20.2
Mid case bearing holder mounting screw	48.1 to 55.9	4.9 to 5.7	35.4 to 41.2
Brake plate mounting screw (PTO clutch)	9.8 to 11.3	1.00 to 1.15	7.2 to 8.3
Rear wheel mounting nut	215	22	160
Rear wheel mounting stud bolt	98.1 to 112.8	10.0 to 11.5	72.3 to 83.2
Lift arm pin mounting nut	77.5 to 90.2	7.9 to 9.2	57.1 to 66.5
Lift arm pin lock nut	62.8 to 72.6	6.4 to 7.4	46.3 to 53.5
Drawbar frame mounting screw (M12)	77.5 to 90.2	7.9 to 9.2	57.1 to 66.5
(M14)	167 to 196	17.0 to 20.0	123 to 145
Hydraulic cylinder hose	34.3 to 48.1	3.5 to 4.9	25.3 to 35.4
ROPS lower frame mounting screw	167 to 196	17.0 to 20.0	123 to 145
Joint bolt for main delivery pipe	49 to 69	5.0 to 7.0	36.1 to 50.6
Rear axle case mounting screw and nut			
M10 screw and nut (7T)	48.1 to 55.9	4.9 to 5.7	35.4 to 41.2
Stud bolt	24.5 to 31.4	2.5 to 3.2	18.1 to 23.1
M10 nut (9T)	60.8 to 70.6	6.2 to 7.2	44.9 to 52.1
M12 screw	77.5 to 90.2	7.9 to 9.2	57.1 to 66.5
Brake case mounting stud bolt	29.4 to 49.0	3.0 to 5.0	21.7 to 36.1
Brake case mounting screw and nut	77.5 to 90.2	7.9 to 9.2	57.1 to 66.5
Lever fulcrum screw	62.8 to 72.5	6.4 to 7.4	46.3 to 53.5
Lock nut (pinion shaft)	147 to 196	15 to 20	108 to 145
Pinion bearing case mounting screw	39.2 to 44.1	4.0 to 4.5	28.9 to 32.5
Transmission bearing holder mounting screw	48.1 to 55.9	4.9 to 5.7	35.5 to 41.2
Lock nut (PTO shaft)	147 to 196	15 to 20	108 to 145
Bearing case mounting screw	23.5 to 27.5	2.4 to 2.8	17.4 to 20.3
Differential support mounting screw	48.1 to 55.9	4.9 to 5.7	35.4 to 41.2
Differential case cover mounting screw	48.1 to 55.9	4.9 to 5.7	35.4 to 41.2
Spiral bevel gear UBS screw	68.6 to 88.3	7.0 to 9.0	50.6 to 65.1
Muffler mounting screw	31.4 to 37.2	3.2 to 3.8	23.1 to 27.5

W1012736

Item	N·m	kgf·m	ft-lbs
(Cabin)			
Compressor mounting screw	24.5 to 29.4	2.5 to 3.0	18.1 to 21.7
Cabin mounting bolt and nut	124 to 147	12.6 to 15.0	91.1 to 108
(Manual Transmission)			
Main shift base mounting screw	23.5 to 27.5	2.4 to 2.8	17.4 to 20.3
Main shift arm setting screw	9.8 to 11.3	1.00 to 1.15	7.2 to 8.3
Clutch housing bearing holder mounting screw	48.1 to 55.9	4.9 to 5.7	35.4 to 41.2
Stopper screw	34.3 to 44.1	3.5 to 4.5	25.3 to 32.5
(GST)			
Joint bolt for GST delivery pipe	34 to 39	3.5 to 4.0	25.3 to 28.9
Shift pin mounting screw	12.7 to 14.7	1.3 to 1.5	9.4 to 10.8
GST valve mounting screw	42.2 to 48.1	4.3 to 4.9	31.1 to 35.4
Clutch housing bearing holder mounting screw	48.1 to 55.9	4.9 to 5.7	35.4 to 41.2
Stopper screw	34.3 to 44.1	3.5 to 4.5	25.3 to 32.5
Joint bolt for GST delivery pipe and regulating valve	34.3 to 39.2	3.5 to 4.0	25.3 to 28.9
Joint bolt for power steering hose and regulating valve	49.0 to 68.6	5.0 to 7.0	36.2 to 50.6
Joint bolt for delivery pipe and hydraulic pump	39.3 to 49.0	4.0 to 5.0	29.0 to 36.2
Regulating valve mounting screw	17.6 to 20.6	1.8 to 2.1	13.0 to 15.2
Joint bolt	49.0 to 58.8	5.0 to 6.0	36.2 to 43.4
Plate	9.8	1.0	7.2
Regulating valve case and support mounting screw	9.8	1.0	7.2
Lower body mounting hex. socket head cap screw	9.8 to 10.8	1.0 to 1.1	7.2 to 8.0
(HST)			
HST control lever setting hex. head screw	6.86 to 8.33	0.70 to 0.85	5.06 to 6.15
Joint bolt for oil cooler pipe	34 to 39	3.5 to 4.0	25.3 to 28.9
Joint bolt for charge delivery pipe to filter bracket	39 to 49	3.5 to 4.0	25.3 to 28.9
Cap nut for charge delivery pipe	49 to 59	5.0 to 6.0	36.1 to 43.4
Port block mounting hex. head screw	98 to 123	10.0 to 12.5	72.3 to 90.4
Swashplate setting hex. head screw	28 to 35	2.9 to 3.6	21 to 26
Cradle bearing bracket mounting hex. head screw	28 to 35	2.9 to 3.6	21 to 26
Charge pump case mounting screw	28 to 35	2.9 to 3.6	21 to 26
Hex. head plug	30 to 37	3.1 to 3.8	22.4 to 27.5
Hex. head plug	56 to 68	5.5 to 7.0	39.8 to 50.6
Regulator mounting hex. head screw	6.9 to 8.3	0.7 to 0.85	5.1 to 6.1
Servo piston and cover mounting hex. head screw	28 to 35	2.9 to 3.6	21 to 26
Joint bolt for PTO pipe to PTO clutch valve	34 to 39	4.0 to 5.0	28.9 to 36.1

W1012736

# 4. CHECKING, DISASSEMBLING AND SERVICING

## [1] MANUAL TRANSMISSION MODEL

### (1) Checking and Adjusting

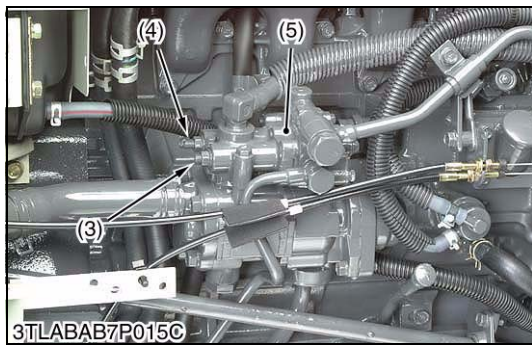
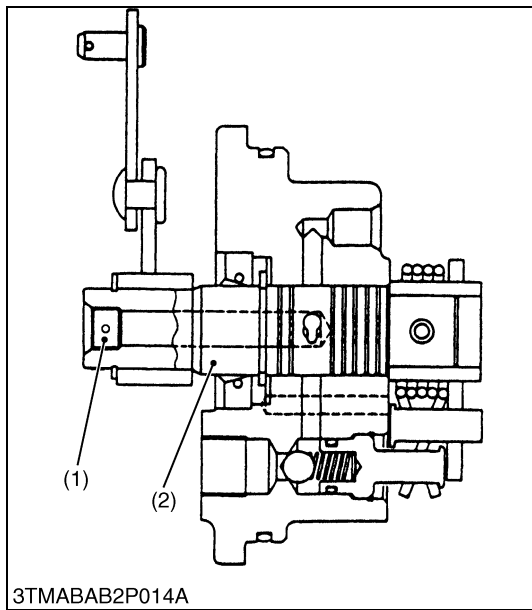
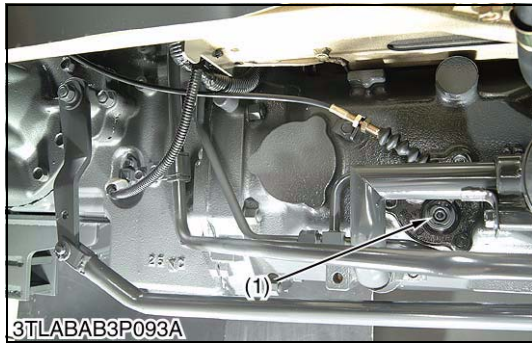

#### Operating Pressure of PTO Clutch Valve

1. Start the engine and warm up the transmission fluid, and then stop the engine.
2. Remove the plug (1) (PT 1/8) on the PTO valve spool (2).
3. Set the pressure gauge.
4. Start the engine and measure the pressure.
5. For adjustment use the pressure reducing valve adjustor (3) of the regulating valve assembly (5).

#### ■ IMPORTANT

- Do not connect the universal joint of the implement to the tractor PTO shaft while testing.

PTO operating pressure	When PTO shift lever is "ENGAGED" position	2.30 to 2.50 MPa 23.5 to 25.5 kgf/cm <sup>2</sup> 334 to 363 psi
	When PTO shift lever is "DISENGAGED" position	No pressure

#### Condition

- Engine speed ..... Idling speed
- Oil temperature ..... 40 to 60 °C  
104 to 140 °F

#### (Reference)

- Turn to clockwise direction → Pressure is increased
- Turn to counterclockwise direction → Pressure is decreased

- (1) Plug (PT 1/8)
- (2) Spool
- (3) Pressure Reducing Valve Adjustor
- (4) Regulating Valve Adjustor
- (5) Regulating Valve Assembly

W1012774

## (2) Disassembling and Assembling

### (A) Clutch Housing

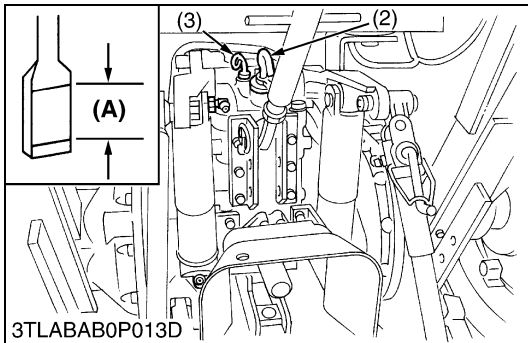
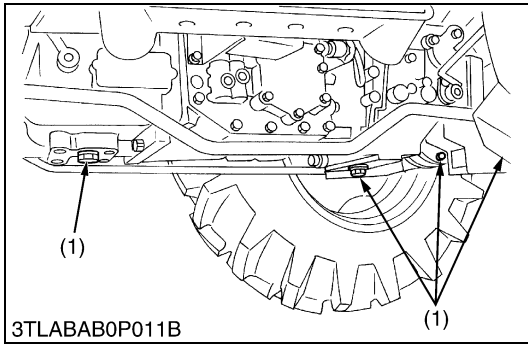

#### Draining the Transmission Fluid

1. Place oil pans underneath the transmission case.
2. Remove the drain plugs (1).
3. Drain the transmission fluid.
4. Reinstall the drain plugs (1).

#### (When refilling)

- Fill up from filling port after removing the filling plug (2) until reaching the upper notch on the dipstick (3).
- After running the engine for few minutes, stop it and check the oil level again, add the fluid to prescribed level if it is not correct level.

Transmission fluid capacity	L3130 L3430	42 L 11.1 U.S.gals 9.2 Imp.gals
	L3830 L4630	43 L 11.4 U.S.gals 9.5 Imp.gals
	L5030	45 L 11.9 U.S.gals 9.9 Imp.gals

#### ■ IMPORTANT

- Use only KUBOTA SUPER UDT fluid. Use of other oils may damage the transmission or hydraulic system. Refer to “LUBRICANTS, FUEL AND COOLANT”. (See page G-7, 8.)
- Do not mix different brands of fluid together.

- (1) Drain Plugs  
(2) Filling Plug  
(3) Dipstick

(A) Oil level is acceptable within this range.

W1012748

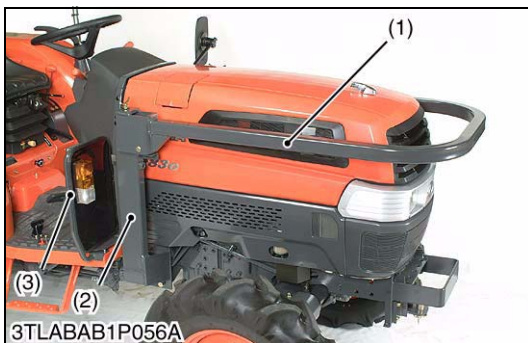

#### ROPS (Center ROPS Type)

1. Remove the upper frame (1) from ROPS lower frame (2).
2. Disconnect the light connectors.
3. Remove the shields (3).
4. Remove the lower frames (2).

#### (When reassembling)

#### ■ NOTE

- Do not firmly tighten all screws until most components are attached.

Tightening torque	Lower frame mounting screw	260 to 304 N-m 26.5 to 31.0 kgf-m 192 to 224 ft-lbs
-------------------	----------------------------	---

- (1) Upper Frame  
(2) Lower Frame  
(3) Shield

W1049334



**Battery, Front Grill, Skirt and Bonnet**

1. Open the bonnet (1) and disconnect the battery negative cable.
2. Disconnect the head light connector and remove the front grill (3).
3. Remove the left and right side skirts (2).
4. Remove the bonnet (1).

■ **NOTE**

- **When disconnecting the battery cords, disconnect the negative cord first, when connecting, positive cord first.**

- (1) Bonnet
- (2) Skirt
- (3) Front Grill

W1013500

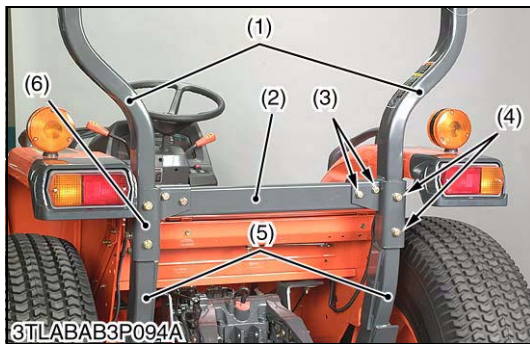

**ROPS**

1. Remove the lower connector (2).
2. Remove the plate mounting screws (4), (8).
3. Remove the upper frame (1) from ROPS lower frame (5).

**(When reassembling)**

■ **NOTE**

- **Do not firmly tighten all screws until most components are attached.**

Tightening torque	Lower connector mounting screw (3)	103 to 118 N-m 10.5 to 12.0 kgf-m 75.9 to 86.8 ft-lbs
	Plate mounting screw (4)	138 to 147 N-m 14.0 to 15.0 kgf-m 102 to 108 ft-lbs
	Plate mounting screw (8)	167 to 196 N-m 17.0 to 20.0 kgf-m 123 to 145 ft-lbs

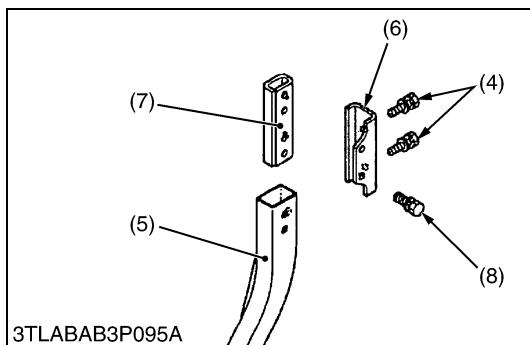

**(Reference)**

Tightening torque	Fulcrum bolt and nut (9)	118 to 137 N-m 12.0 to 14.0 kgf-m 86.8 to 102 ft-lbs
-------------------	--------------------------	--

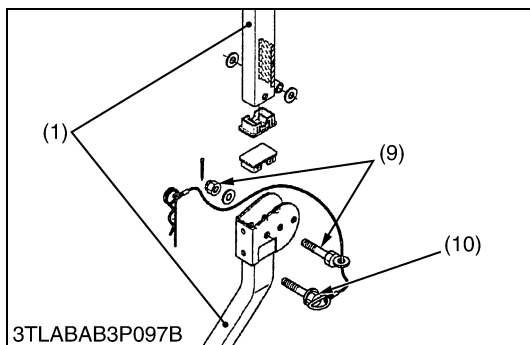

- (1) Upper Frame
- (2) Lower Connector
- (3) Screw (M12 × 65)
- (4) Screw (M14 × 40)
- (5) Lower Frame
- (6) Plate
- (7) Connector
- (8) Screw (M14 × 30)
- (9) Fulcrum Bolt and Nut
- (10) Lock Bolt

W1051168



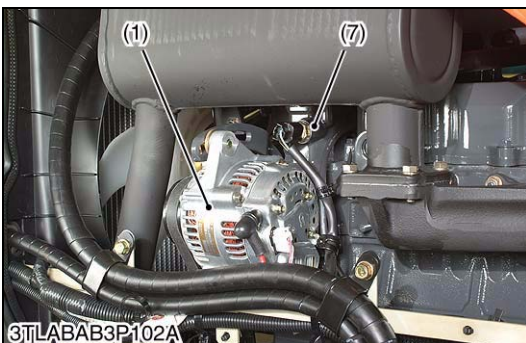
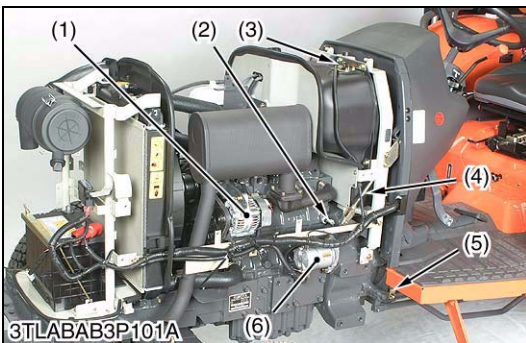
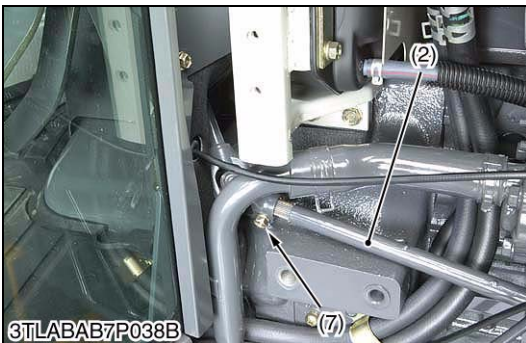
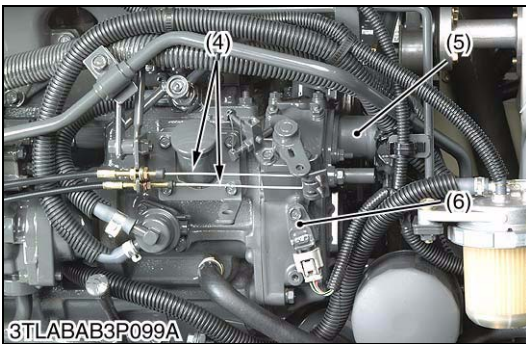
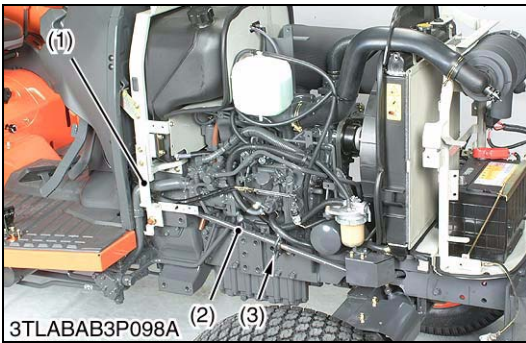

### **Steering Joint, Brake Pedal Rod and Electric Wiring**

1. Remove the tank frame support (1).
2. Remove the universal joint bolt (7) and steering joint support (3), and then remove the steering joint (2).
3. Disconnect the hand accelerator wire and foot accelerator wire (4).
4. Disconnect the wiring connectors for engine stop solenoid (5) engine tachometer sensor (6) and glow plug.
5. Disconnect the brake pedal rod.

#### **(When reassembling)**

- When accelerator wire is installed, adjust the wire length as hit both the idling speed adjusting bolt and the maximum speed adjusting bolt by lever within the stroke of the accelerator lever.
- Set the steering joint (2) by the joint support (3) so that the steering wheel is turned lightly.
- Be sure to check and adjust the brake pedal free travel. (See page G-18.)

- |                            |                              |
|----------------------------|------------------------------|
| (1) Tank Frame Support     | (5) Engine Stop Solenoid     |
| (2) Steering Joint         | (6) Engine Tachometer Sensor |
| (3) Steering Joint Support | (7) Universal Joint Bolt     |
| (4) Accelerator Wire       |                              |

W1014002

### **Clutch Rod, Brake Pedal Rod and Electric Wiring**

1. Disconnect the brake pedal rod (5) and clutch pedal rod (4).
2. Disconnect the wiring connectors for alternator (1), coolant temperature sensor (7), oil pressure switch (2), fuel unit (3), starter motor (6) and battery.
3. Remove the clamps and ground earth of wiring harness and collect wiring harness to the step.

#### **(When reassembling)**

- Be sure to check and adjust the clutch and brake pedal free travel. (See page G-18, 24.)

- |                         |                                |
|-------------------------|--------------------------------|
| (1) Alternator          | (5) Brake Pedal Rod            |
| (2) Oil Pressure Switch | (6) Starter Motor              |
| (3) Fuel Unit           | (7) Coolant Temperature Sensor |
| (4) Clutch Pedal Rod    |                                |

W1014368

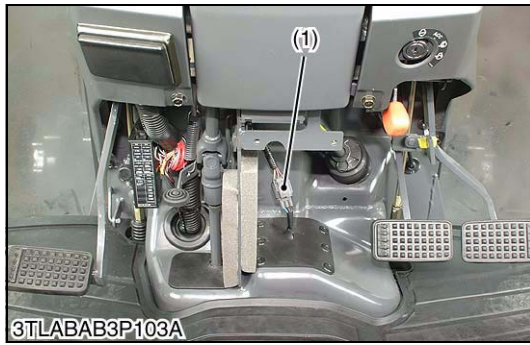

### **Shuttle Switch Connector**

1. Remove the panel cover and steering post cover.
2. Disconnect the shuttle switch connector (1).

(1) Shuttle Switch Connector

W1014526



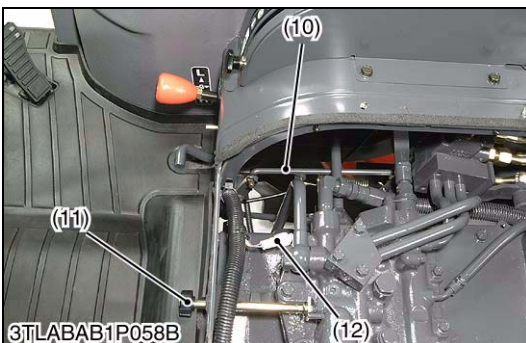
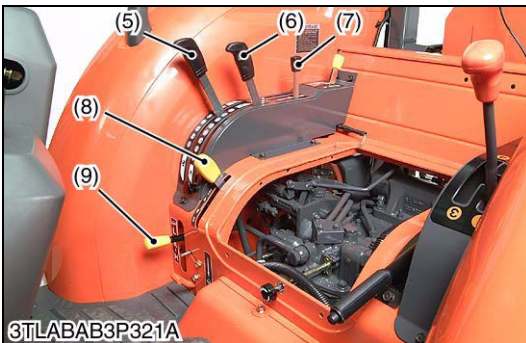
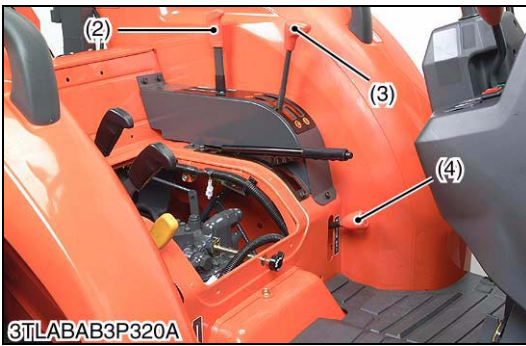

### Seat and Lever Grips

1. Remove the seat (1) with seat bracket.
2. Remove the lever grip for main shift lever (3), range gear shift lever (2), front wheel drive lever (4), auxiliary control lever (7), position control lever (6), draft control lever (5) (if equipped), ground PTO lever (8) (if equipped) and PTO gear shift lever (9) (if equipped).
3. Disconnect the differential lock rod (10).
4. Remove the lowering speed adjusting knob (11).
5. Disconnect the PTO speed change connector (12).

- |                             |                                 |
|-----------------------------|---------------------------------|
| (1) Seat                    | (7) Auxiliary Control Lever     |
| (2) Range Gear Shift Lever  | (8) Ground PTO Lever            |
| (3) Main Shift Lever        | (9) PTO Gear Shift Lever        |
| (4) Front Wheel Drive Lever | (10) Differential Lock Rod      |
| (5) Draft Control Lever     | (11) Lower Speed Adjusting Knob |
| (6) Position Control Lever  | (12) PTO Speed Change Connector |

W1053470

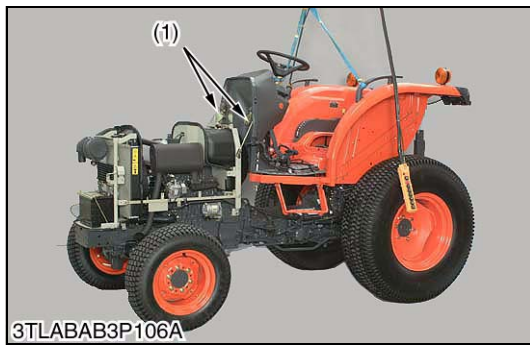

**Step and Floor Seat**

1. Disconnect the ground cable which is attached on left side of transmission case.
2. Disconnect the panel frame connector (1) from fuel tank frame.
3. Remove the step and floor seat mounting bolt and nut.
4. Dismount the step, fender, floor seat and panel frame as a unit after checking whether there is forgetting to disconnect wiring.

**(When reassembling)**

- Be sure to set the washers and rubber plates of the floor seat and step mounting bolt at an original positions as shown in figure.
- Before mounting the floor seat and step, be sure to set both the shuttle lever rod and the shuttle arm to the neutral position, and then connect the shuttle lever rod securely.

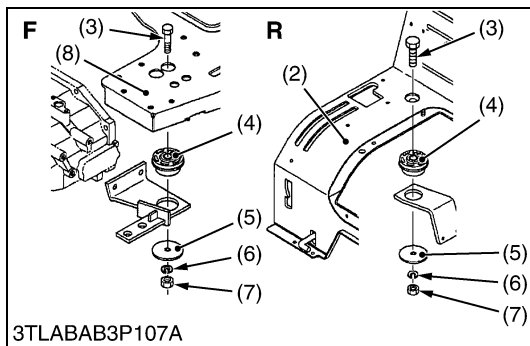

Tightening torque	Step mounting bolt and nut	124 to 147 N·m 12.6 to 15.0 kgf·m 91.1 to 108 ft·lbs
	Floor seat mounting bolt and nut	196 to 225 N·m 20 to 23 kgf·m 145 to 166 ft·lbs

- (1) Panel Frame Connector
  - (2) Floor Seat
  - (3) Bolt
  - (4) Rubber Plate
  - (5) Washer
  - (6) Spring Washer
  - (7) Nut
  - (8) Step
- F : Front Side**  
**R : Rear Side**

W1015069

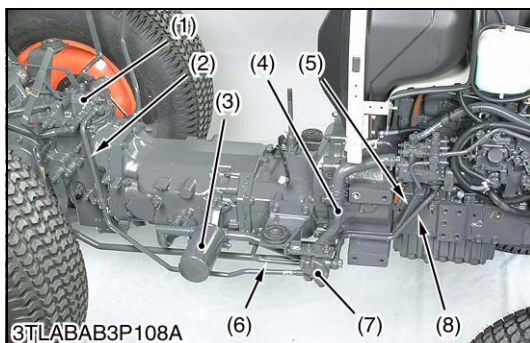

**Hydraulic Pipes**

1. Remove the main delivery pipe 1 (8).
2. Disconnect the main delivery pipe 2 (2) at the rear hydraulic block (1) and return pipe (6) at the mid case, and then remove the front hydraulic block (7) with pipes and bracket as a unit.
3. Remove the suction pipe (4) with oil filter (3).
4. Remove the PTO delivery pipe (5).

**(When reassembling)**

Tightening torque	Joint bolt for main delivery pipe 1 to front hydraulic block	49 to 69 N·m 5.0 to 7.0 kgf·m 36.1 to 50.6 ft·lbs
	Joint bolt for main delivery pipe 2 to rear hydraulic block	49 to 69 N·m 5.0 to 7.0 kgf·m 36.1 to 50.6 ft·lbs
	Cap nut for return pipe to mid case	49 to 69 N·m 5.0 to 7.0 kgf·m 36.1 to 50.6 ft·lbs
	Joint bolt for PTO delivery pipe	34 to 39 N·m 3.5 to 4.0 kgf·m 25.3 to 28.9 ft·lbs

- (1) Rear Hydraulic Block
- (2) Main Delivery Pipe 2
- (3) Hydraulic Oil Filter
- (4) Suction Pipe
- (5) PTO Delivery Pipe
- (6) Return Pipe
- (7) Front Hydraulic Block
- (8) Main Delivery Pipe 1

W1015283

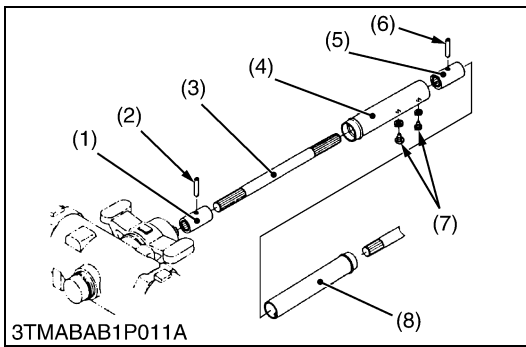

### Propeller Shaft

1. Slide the propeller shaft cover (4) and (8) after removing the screws (7).
2. Tap out the spring pins (2), (6) and slide the couplings (1), (5) and then remove the propeller shaft with covers (4), (8).

#### (When reassembling)

- Apply grease to the splines of propeller shaft 1 (3).

- |                           |                           |
|---------------------------|---------------------------|
| (1) Coupling              | (5) Coupling              |
| (2) Spring Pin            | (6) Spring Pin            |
| (3) Propeller Shaft 1     | (7) Screws                |
| (4) Propeller Shaft Cover | (8) Propeller Shaft Cover |

W1015712

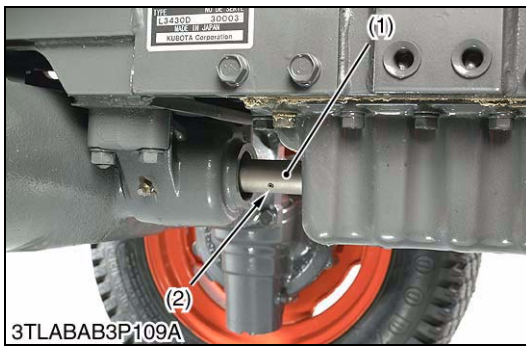

### Separating Engine and Clutch Housing

1. Place the disassembling stand under the engine and clutch housing case.
2. Remove the fuel tank support mounting bolts.
3. Remove the engine and clutch housing mounting screws and nuts.
4. Separate the engine and clutch housing while lifting up the tank frame.

#### (When reassembling)

- Apply grease to the spline of clutch shaft.
- Apply liquid gasket (Three Bond 1211 or equivalent) to joint face of the flywheel housing and clutch housing.

Tightening torque	Engine and clutch housing mounting screw and nut	77.5 to 90.2 N·m 7.9 to 9.2 kgf·m 57.1 to 66.5 ft·lbs
	Engine and clutch housing mounting stud bolt	39.2 to 49.0 N·m 4.0 to 5.0 kgf·m 28.9 to 36.2 ft·lbs

W1015876



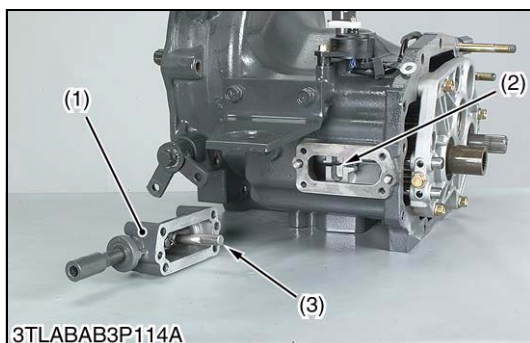
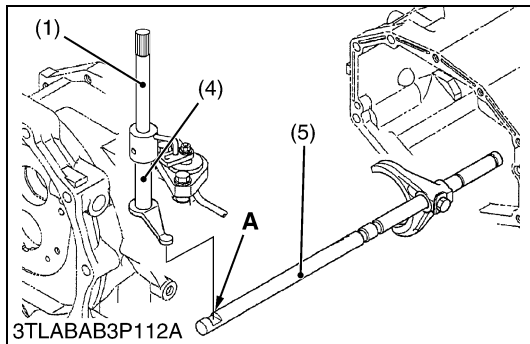
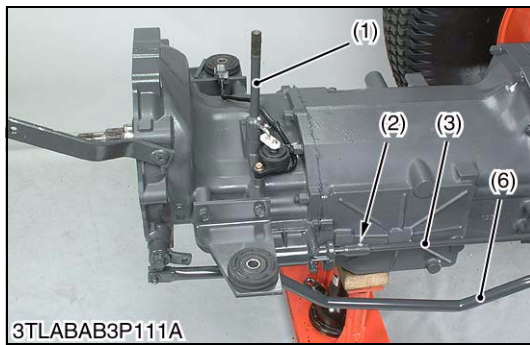

**Shift Levers**

1. Disconnect the brake rods (6).
2. Tap out the spring pins (2) of main shift rod 1 (3).
3. Remove the shuttle shift arm stopper mounting screw, and then pull the shuttle shift shaft (1) with arm (4) up.

**(When reassembling)**

- Tap in the spring pins (2) so that their split portion may face forward.
- When reassembling the shuttle shift arm (4) to the shuttle fork rod (5), be sure to install it to the groove **A**.

- |                         |                      |
|-------------------------|----------------------|
| (1) Shuttle Shift Shaft | (5) Shuttle Fork Rod |
| (2) Spring Pin          | (6) Brake Rod        |
| (3) Main Shift Rod 1    |                      |
| (4) Shuttle Shift Arm   |                      |
- A : Fork Rod Groove**

W1016127

**Separating Clutch Housing and Mid Case**

1. Remove the clutch housing and mid case mounting screws and nuts.
2. Separate the clutch housing and mid case.

**(When reassembling)**

- Apply liquid gasket (Three Bond 1208D or equivalent) to joint face of the clutch housing and mid case.

Tightening torque	Clutch housing and mid case mounting nut	102.9 to 117.6 N·m 10.5 to 12.0 kgf·m 75.9 to 86.8 ft·lbs
	Clutch housing and mid case mounting screw	77.5 to 90.2 N·m 7.9 to 9.2 kgf·m 57.1 to 66.5 ft·lbs
	Clutch housing and mid case mounting stud bolt	38.2 to 45.1 N·m 3.9 to 4.6 kgf·m 28.2 to 33.3 ft·lbs

W10134850

**Main Shift Base**

1. Remove the main shift base mounting screws.
2. Take out the main shift base (1) and main shift arm (3) as a unit.

**(When reassembling)**

- Apply liquid gasket (Three Bond 1208D or equivalent) to joint face of the clutch housing case and main shift base.
- The main shift arm should be fitted on to the shift fork grooves (2) after setting the shift forks to neutral position.

Tightening torque	Main shift base mounting screw	23.5 to 27.5 N·m 2.4 to 2.8 kgf·m 17.4 to 20.3 ft·lbs
	Main shift arm setting screw	9.8 to 11.3 N·m 1.00 to 1.15 kgf·m 7.2 to 8.3 ft·lbs

- |                        |                    |
|------------------------|--------------------|
| (1) Main Shift Base    | (3) Main Shift Arm |
| (2) Shift Fork Grooves |                    |

W1016861

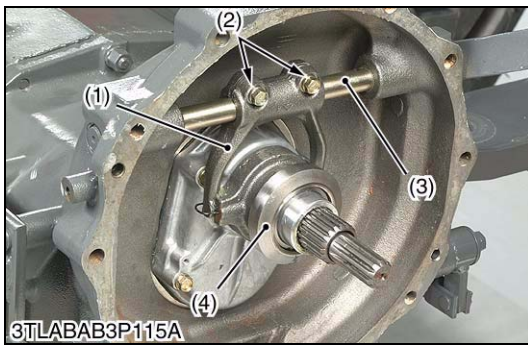

### Clutch Lever, Release Fork and Release Bearing

1. Remove the release fork mounting screws (2).
2. Draw out the clutch lever (3) to remove the release fork (1).
3. Remove the release bearing and release hub (4) together.

#### (When reassembling)

- Apply grease to the sliding surface of the clutch release hub.
- Apply grease to the clutch lever.

Tightening torque	Release fork mounting screw	23.5 to 27.5 N·m 2.4 to 2.8 kgf·m 17.4 to 20.3 ft·lbs

- (1) Release Fork (3) Clutch Lever  
(2) Release Fork Mounting Screw (4) Release Hub

W10126560

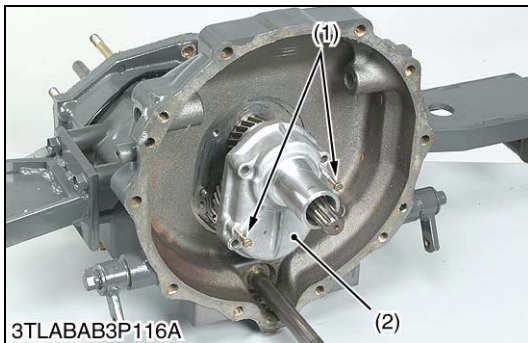

### Shaft Case

1. Remove the shaft case mounting screws.
2. Screw down the two M6 screws (1) into the shaft case (2) and pull it out.
3. Take out the shaft case (2).

#### (When reassembling)

- Apply liquid gasket (Three Bond 1208D or equivalent) to joint face of the shaft case and clutch housing case.

#### (When replacing oil seal in shaft case)

- Install the oil seal (3) as shown in the figure, noting its direction.
- Apply grease to the oil seal (3).

- (1) M6 Screw (3) Oil Seal  
(2) Shaft Case

W10128390

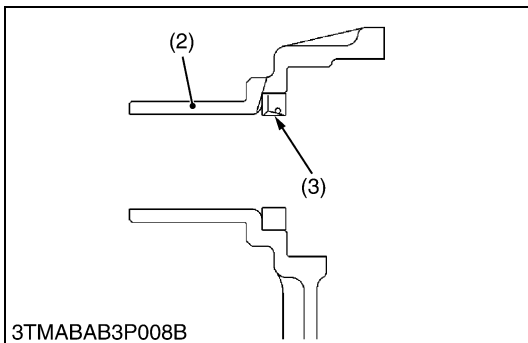

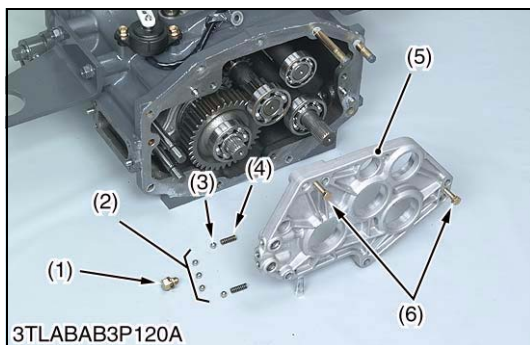
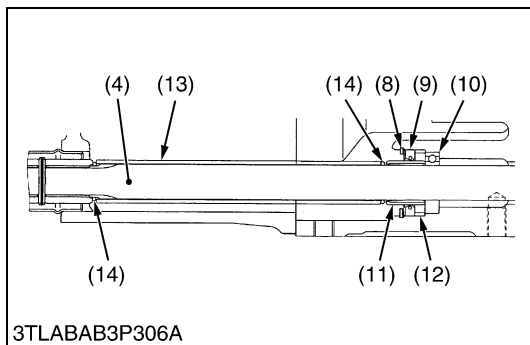
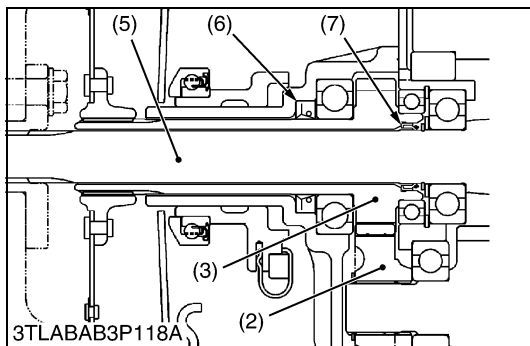
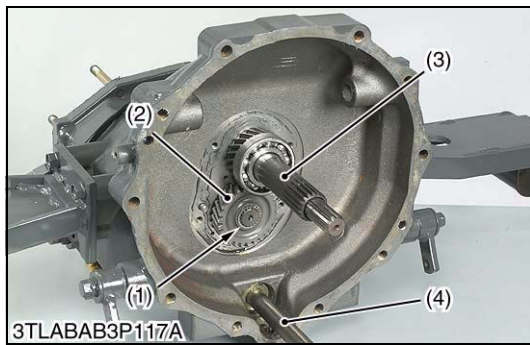

**23T (24T) Gear Shaft, 27T (26T) Gear and Front Axle Drive Shaft**

1. Remove the 23T gear shaft (3).
2. Remove the external snap ring (1) and 27T gear (2).
3. Pull out the front axle drive shaft (4) to the rear side.

**(When reassembling)**

- Install the oil seal (7) on the 18T gear shaft (5), noting the direction of the oil seal (7) as shown in the figure.
- Direct the boss side of the gear (2) to the bearing side.
- Apply small amount of the grease to the oil seal (6), (7).
- Install the front axle drive shaft (4) from front side after assembling the clutch housing case and mid case. Then install the bearing (10), sleeve (11), collar (12), oil seal (9), internal snap ring (8), O-ring (14) and spacer (13) in order.

- |  |                        |
|--|------------------------|
| (1) External Snap Ring                       | (8) Internal Snap Ring |
| (2) 27T Gear<br>26T Gear (L5030)             | (9) Oil Seal           |
| (3) 23T Gear Shaft<br>24T Gear Shaft (L5030) | (10) Bearing           |
| (4) Front Axle Drive Shaft                   | (11) Sleeve            |
| (5) 18T Gear Shaft                           | (12) Collar            |
| (6) Oil Seal                                 | (13) Spacer            |
| (7) Oil Seal                                 | (14) O-ring            |
- F : Front Side**

W1017151

**Clutch Housing Bearing Holder**

1. Remove the three interlock balls (2) after removing the stopper screw (1).
2. Pull out the clutch housing bearing holder (5) with using two jack bolts (6).

**NOTE**

- Take care not to fly out the balls (3) and springs (4) when pull out the bearing holder (1).

**(When reassembling)**

- Tap in the clutch housing bearing holder (5) with plastic hammer until contact to clutch housing case, and then tighten the screws to specified torque.
- Install the three interlock balls (2) with a small amount of grease to the clutch housing bearing holder (5) after setting the shift forks and shift rods to the neutral position.

Tightening torque	Clutch housing bearing holder mounting screw	48.1 to 55.9 N·m 4.9 to 5.7 kgf·m 35.4 to 41.2 ft·lbs
	Stopper screw	34.3 to 44.1 N·m 3.5 to 4.5 kgf·m 25.3 to 32.5 ft·lbs

- |                    |                                   |
|--------------------|-----------------------------------|
| (1) Stopper Screw  | (4) Spring                        |
| (2) Interlock Ball | (5) Clutch Housing Bearing Holder |
| (3) Ball           | (6) Jack Bolt                     |

W1017551

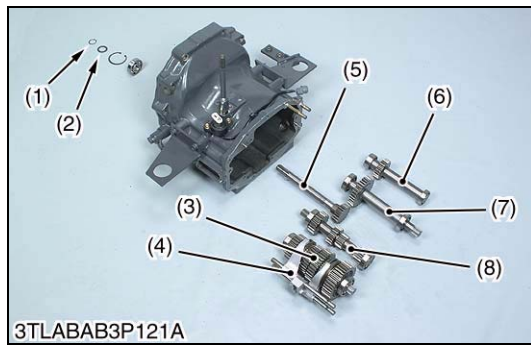

3TLABAB3P121A

**Shaft Assemblies**

1. Remove the external snap ring (1) and collar (2).
2. Draw out the shaft assemblies (3), (5), (6), (7), (8).

(1) External Snap Ring	(5) 18T Gear Shaft Assembly
(2) Collar	(6) Idle Shaft Assembly
(3) Counter Shaft Assembly	(7) PTO Counter Shaft Assembly
(4) Shift Rods	(8) Main Gear Shaft Assembly

W1017774

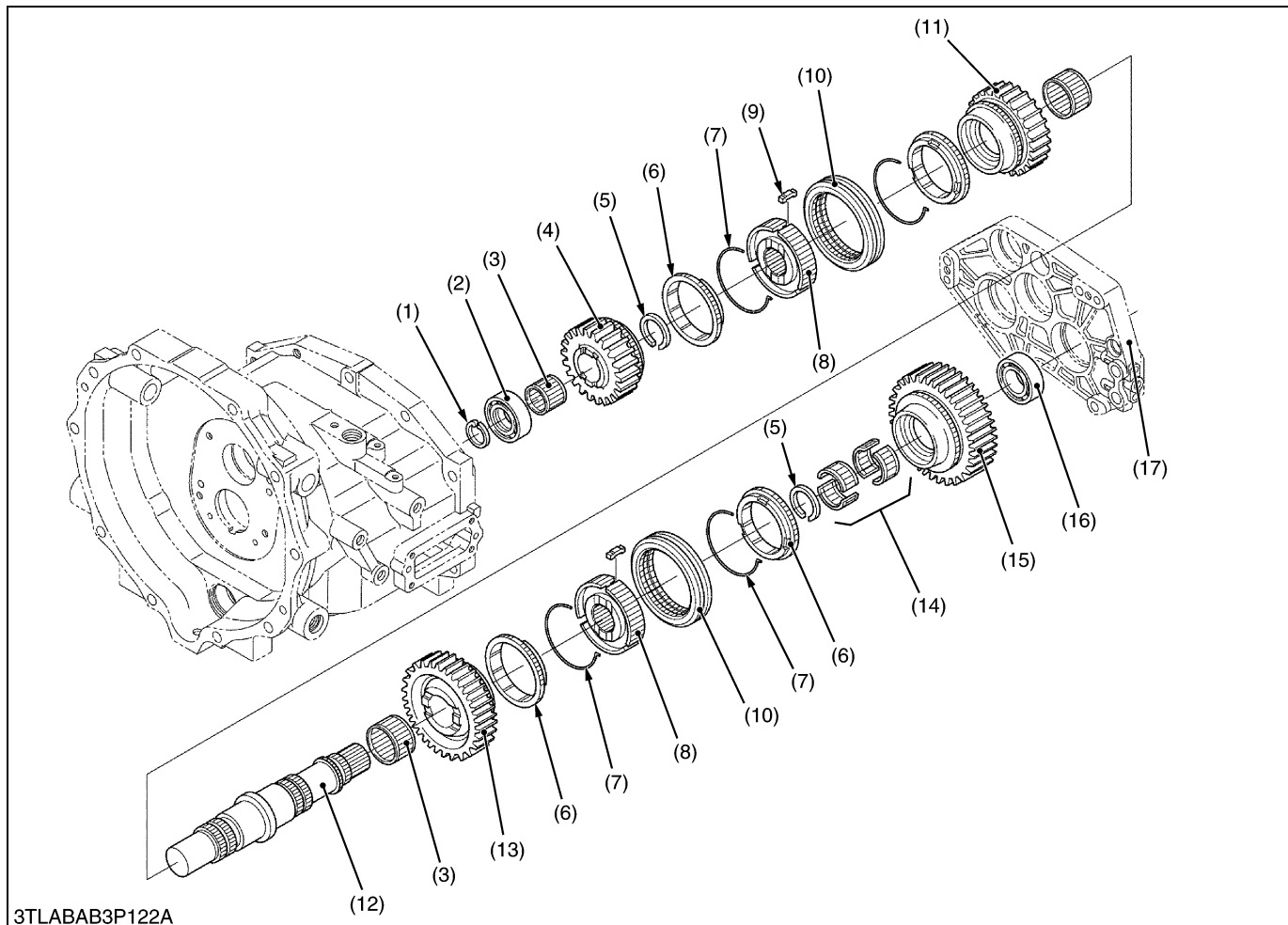
**Counter Shaft**

3TLABAB3P122A

(1) Internal Snap Ring	(6) Synchronizer Ring	(10) Shifter	(14) Needle Bearing
(2) Bearing	(7) Synchronizer Spring	(11) 29T Gear (3rd)	(15) 37T Gear (1st)
(3) Needle Bearing	(8) Hub	(12) Counter Shaft	(16) Bearing
(4) 24T Gear (4th)	(9) Synchronizer Key	(13) 34T Gear (2nd)	(17) Bearing Holder
(5) External Snap Ring			

1. Remove the internal snap ring (1) and remove both side of the bearings (2), (16).
2. Remove the gears on the counter shaft (12) and external snap rings (5).

**(When reassembling)**

- Reinstall the synchronizer keys (9) in the key grooves of the synchronizer rings (6) firmly.



**(B) Mid Case**

■ **NOTE**

- For the disassembling procedure from “Draining the Transmission Fluid” to “Propeller Shaft”, refer to page 3-S18 to 3-S24.

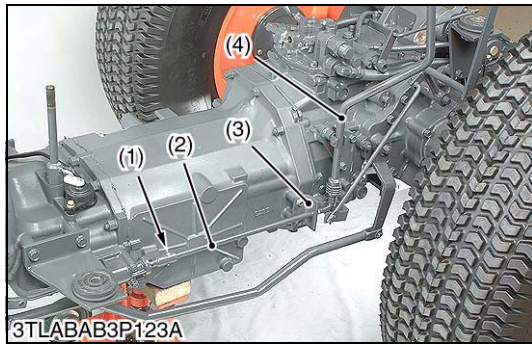

**Main Shift Lever and Brake Rods**

1. Tap out the spring pins (2) of main shift rod (1).
2. Remove the main gear shift lever (4) with the support (3).

**(When reassembling)**

- Tap in the spring pins (2) so that their split portion may face forward.

- (1) Spring Pin
- (2) Main Shift Rod
- (3) Support
- (4) Main Gear Shift Lever

W1018477



**Separating Mid Case and Transmission Case**

1. Separate the mid case and transmission case after removing their mounting screws.

**(When reassembling)**

- Confirm to insert the PTO shaft to PTO clutch firmly, turning the PTO shaft.
- Apply liquid gasket (Three Bond 1208D or equivalent) to joint face of the mid case and transmission case.

Tightening torque	Mid case and transmission case mounting screw	77.5 to 90.2 N·m 7.9 to 9.2 kgf·m 57.1 to 66.5 ft-lbs
	Mid case and transmission case mounting nut	102.9 to 117.6 N·m 10.5 to 12.0 kgf·m 75.9 to 86.8 ft-lbs
	Mid case and transmission case mounting stud bolt	39.2 to 49.0 N·m 4.0 to 5.0 kgf·m 28.9 to 36.2 ft-lbs

W1018604

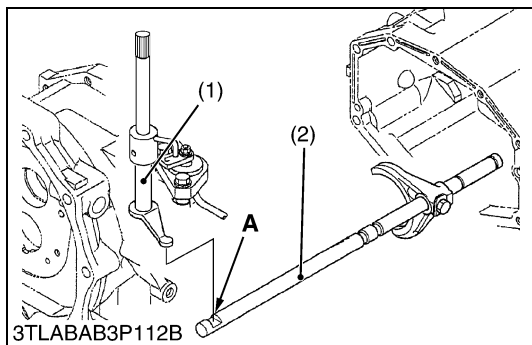

**Separating Mid Case**

1. Lift up the shuttle shift arm (1).
2. Separate the mid case from the clutch housing after removing their mounting screws.

**(When reassembling)**

- Apply liquid gasket (Three Bond 1208D or equivalent) to joint face of clutch housing and mid case.
- When reassembling the shuttle shift arm (1) to the shuttle fork rod (2), be sure to install it to the groove **A**.



Tightening torque	Clutch housing and mid case mounting screw	77.5 to 90.2 N·m 7.9 to 9.2 kgf·m 57.1 to 66.5 ft-lbs
	Clutch housing and mid case mounting nut	102.9 to 117.6 N·m 10.5 to 12.0 kgf·m 75.9 to 86.8 ft-lbs
	Clutch housing and mid case mounting stud bolt	38.2 to 45.1 N·m 3.9 to 4.6 kgf·m 28.2 to 33.3 ft-lbs

- (1) Shuttle Shift Arm
- (2) Shuttle Fork Rod

**A : Fork Rod Groove**

W1018779

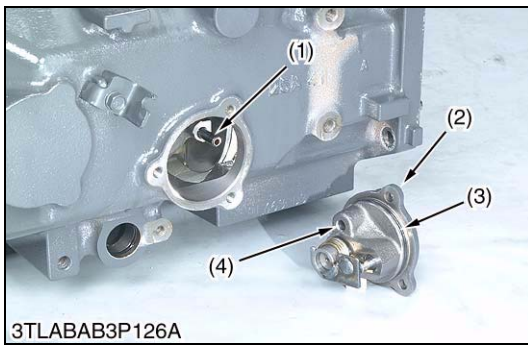

### PTO Clutch Valve

1. Remove the PTO clutch valve (2) as a unit.
2. Pull out the pipe (1).

#### (When reassembling)

- Apply small amount of grease for the O-ring (3).
- Install the pipe (1) to the hole (4) of the PTO clutch valve (2) firmly.
- Replace the pipe (1) with new one.

Tightening torque	PTO clutch valve mounting screw	23.5 to 27.5 N·m 2.4 to 2.8 kgf·m 17.4 to 20.3 ft-lbs
-------------------	---------------------------------	---

- (1) Pipe  
(2) PTO Clutch Valve  
(3) O-ring  
(4) Hole

W1019328

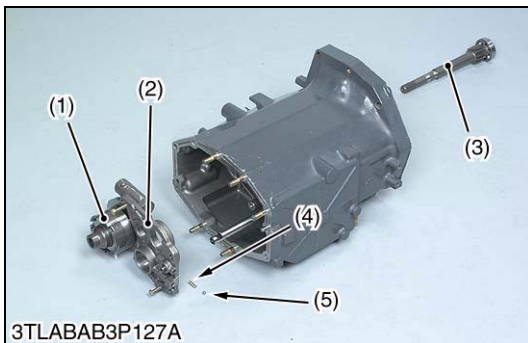

### Mid Case Bearing Holder

1. Remove the PTO drive shaft (3).
2. Remove the mid case bearing holder mounting screws, and then take out the bearing holder (2) with PTO clutch (1) as a unit.

#### ■ NOTE

- Take care not to fly out the ball (5) and spring (4) when pull out the bearing holder (2).

#### (When reassembling)

- Tap in the mid case bearing holder (2) with plastic hammer until contact to mid case, and then tighten the screws to specified torque.

Tightening torque	Mid case bearing holder mounting screw	48.1 to 55.9 N·m 4.9 to 5.7 kgf·m 35.4 to 41.2 ft-lbs
-------------------	--	---

- (1) PTO Clutch  
(2) Mid Case Bearing Holder  
(3) PTO Drive Shaft  
(4) Spring  
(5) Ball

W1019191

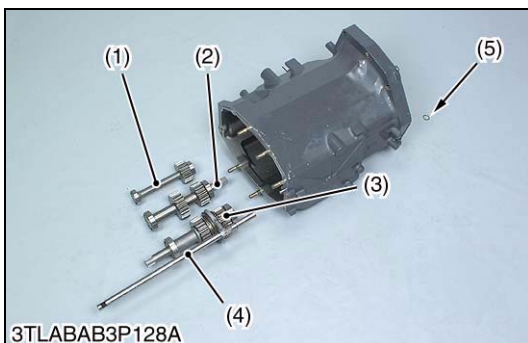

### Shaft Assemblies

1. Remove the external snap ring (5).
2. Draw out the shaft assemblies (1), (2), (3) and shuttle fork rod (4).

- (1) Reverse Gear Shaft  
(2) Shuttle Gear Shaft  
(3) Shuttle Shaft Assembly  
(4) Shuttle Fork Rod  
(5) External Snap Ring

W1019826

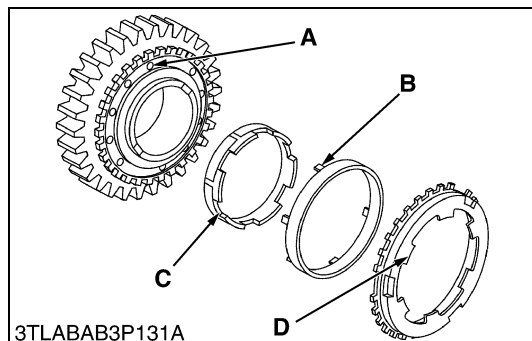
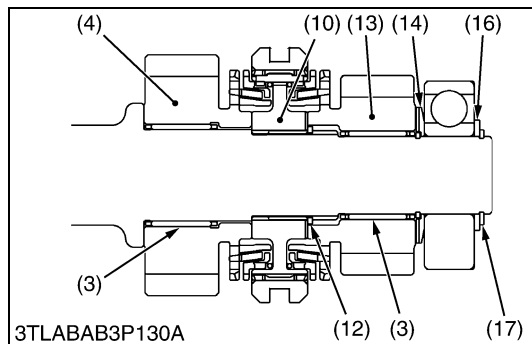
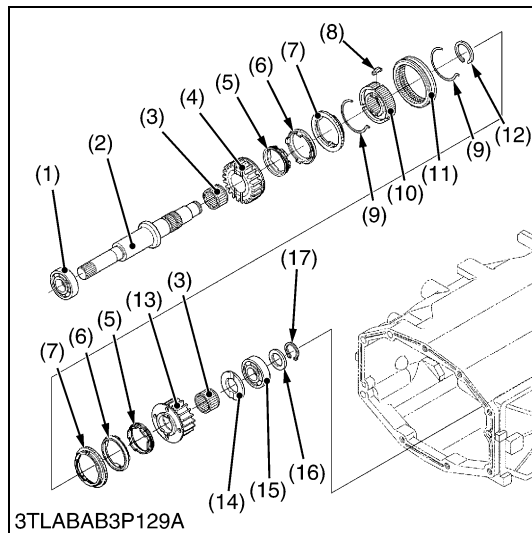

### Shuttle Shaft

1. Remove the external snap ring (17) and collar (16).
2. Draw out the bearing (15) by the bearing puller.
3. Remove the gears, collars and etc..
4. Remove the external snap ring (12), and then remove the hub (10) and other parts.

### (When reassembling)

- Apply enough transmission fluid to the synchronizer portion, needle bearings (3) and thrust collar (14).
- Direct the grooved side of the thrust collar (14) to the needle bearing (3) side.
- Install the protrusion portions (**B**) of the center rings (6) to the holes (**A**) of the gears (4), (13) firmly.
- Install the protrusion portions (**D**) of the outer synchronizer rings (7) to the grooves (**C**) of the inner synchronizer rings (5).
- Install the external snap ring (12) to the groove of the shuttle shaft (2) firmly.
- Install the synchronizer keys (8) in the key grooves of the outer synchronizer rings (7) firmly.

- |                             |  |
|-----------------------------|--|
| (1) Bearing                 | (14) Thrust Collar   |
| (2) Shuttle Shaft           | (15) Bearing   |
| (3) Needle Bearing          | (16) Collar  |
| (4) 24T Gear (Forward)      | (17) External Snap Ring                                      |
| (5) Inner Synchronizer Ring |  |
| (6) Center Ring             | <b>A : Holes of the Gear</b>                                 |
| (7) Outer Synchronizer Ring | <b>B : Protrusion Portion of the Center Ring</b>             |
| (8) Synchronizer Key        | <b>C : Groove of the Inner Synchronizer Ring</b>             |
| (9) Synchronizer Spring     | <b>D : Protrusion Portion of the Outer Synchronizer Ring</b> |
| (10) Hub                    |  |
| (11) Shifter                |  |
| (12) External Snap Ring     |  |
| (13) 18T Gear (Reverse)     |  |

W1019932

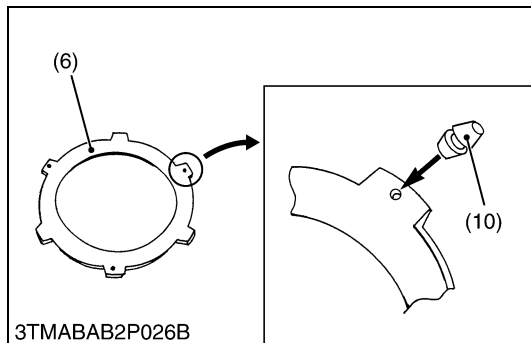
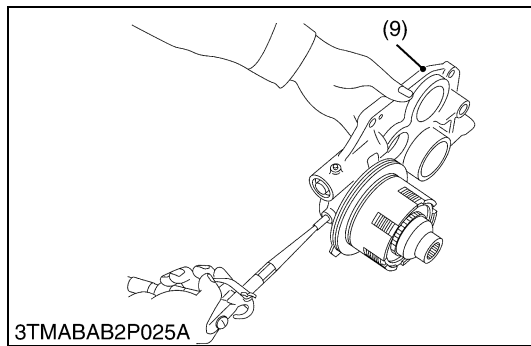
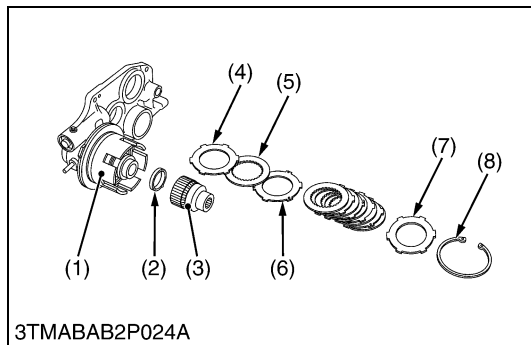

**Clutch Hub and Clutch Discs of PTO Clutch**

1. Remove the internal snap ring (8), and then take out the clutch discs (5), the back plate (7), the steel plates(4) and (6), the hub (3) and the bearing (2).

**(When reassembling)**

- Install the clutch discs (5) and steel plates (4) and (6) mutually. (Refer to figure below.)
- Do not confuse the two types steel plates. The steel plates with the plug rubbers (10) are (6) and without plug rubbers are (4).
- Do not confuse the back plate (7) and steel plates. The back plate (7) is thicker than the steel plates.
- Assemble the plug rubbers portion of the three steel plates (6) are same positions while assembling them. (Refer to figure below.)
- Apply enough transmission fluid to the discs (5).
- Confirm the moving of the piston (11) smoothly when pressure air at 0.29 to 0.39 MPa (3 to 4 kgf/cm<sup>2</sup>, 42 to 57 psi) is sent to clutch pack. (Refer to the figure left.)

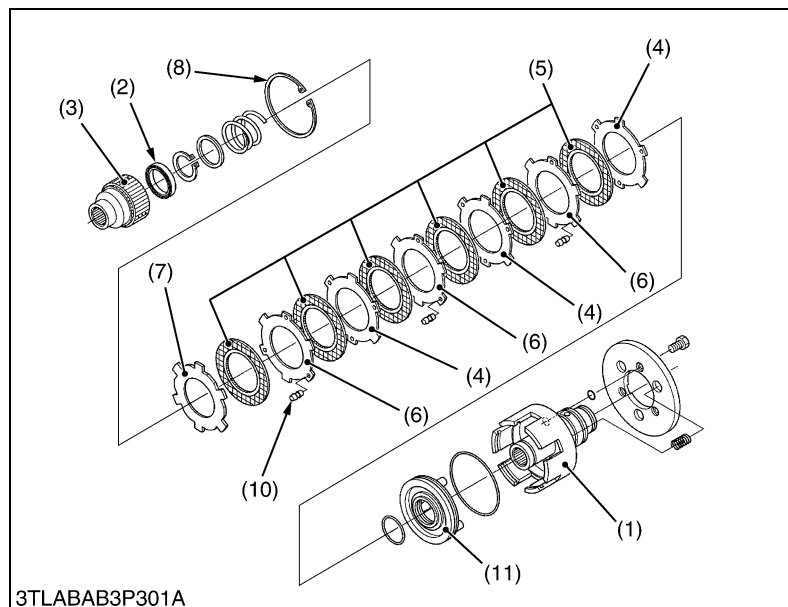

- |                                       |                        |
|---------------------------------------|------------------------|
| (1) Clutch Case                       | (7) Back Plate         |
| (2) Bearing                           | (8) Internal Snap Ring |
| (3) Hub                               | (9) Bearing Holder     |
| (4) Steel Plate (without Plug Rubber) | (10) Plug Rubber       |
| (5) Clutch Disc                       | (11) Piston            |
| (6) Steel Plate (with Plug Rubber)    |                        |

W10159250

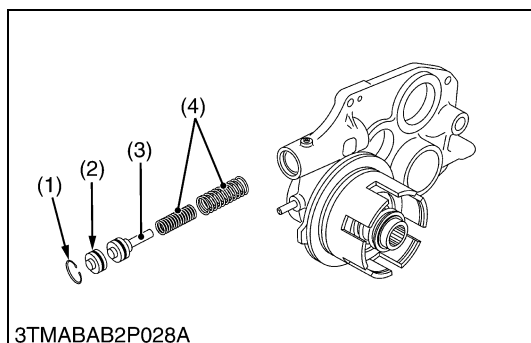

**Accumulator Valve of PTO Clutch**

1. Remove the internal snap ring (1).
2. Remove the spring seat (2).
3. Draw out the spring (4) and piston (3).

- |                        |            |
|------------------------|------------|
| (1) Internal Snap Ring | (3) Piston |
| (2) Spring Seat        | (4) Spring |

W10163300



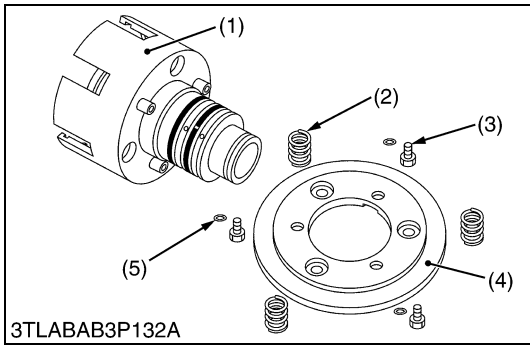
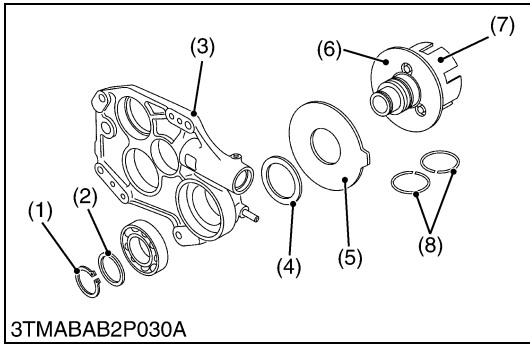
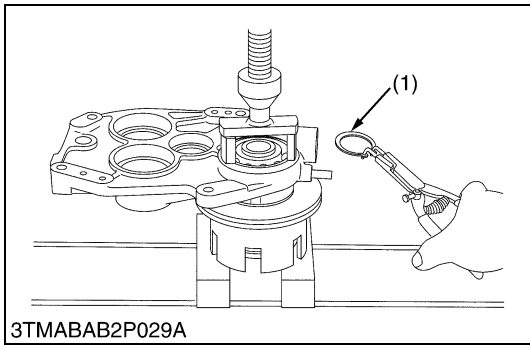

**Clutch Case**

1. Remove the external snap ring (1).
2. Remove the clutch case (7) and brake disc (5).

**(When reassembling)**

- Direct the contact part of the brake disc (5) to the brake plate (6).
- Apply small amount of the grease to the seal rings (8).

- |                        |                 |
|------------------------|-----------------|
| (1) External Snap Ring | (5) Brake Disc  |
| (2) Collar             | (6) Brake Plate |
| (3) Bearing Holder     | (7) Clutch Case |
| (4) Collar             | (8) Seal Ring   |

W10164510

**Brake Plate**

1. Remove the brake plate mounting screws (3) and then take out the brake plate (4) and the springs (2).

**(When reassembling)**

- Apply liquid lock (Three Bond 1372 or equivalent) to the brake plate mounting screws (3).
- Apply grease to the O-rings (5), and be sure to install the three O-rings (5).

Tightening torque	Brake plate mounting screw	9.8 to 11.3 N·m 1.00 to 1.15 kgf·m 7.2 to 8.3 ft·lbs
-------------------	----------------------------	--

- |                                |                 |
|--------------------------------|-----------------|
| (1) Clutch Case                | (4) Brake Plate |
| (2) Spring                     | (5) O-ring      |
| (3) Brake Plate Mounting Screw |                 |

W10167880

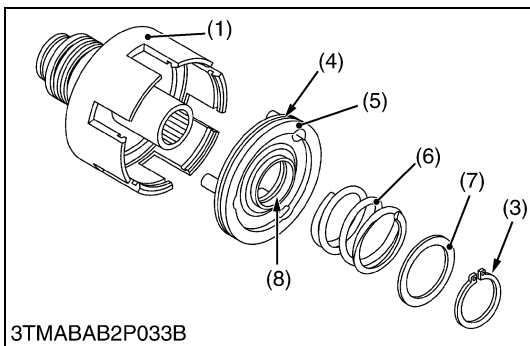
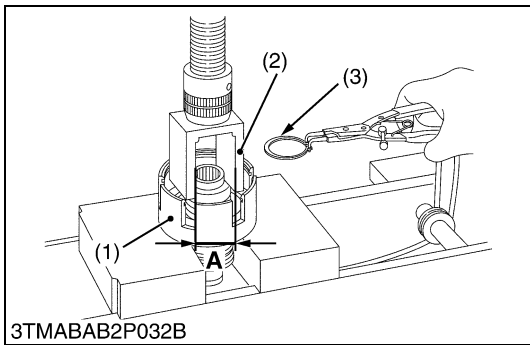

**Piston**

1. Press the washer (7) lightly by the hand press, using the hand made jig. (Refer to the figure left.)
2. Remove the external snap ring (3), washer (7) and spring (6).
3. Draw out the piston (5).

**(When reassembling)**

- Apply enough transmission fluid to seal rings (4) and (8).

- |                        |               |
|------------------------|---------------|
| (1) Clutch Case        | (6) Spring    |
| (2) Jig                | (7) Washer    |
| (3) External Snap Ring | (8) Seal Ring |
| (4) Seal Ring          |               |
| (5) Piston             |               |

**A : 41 mm (1.6 in.)**

W10169240

**(C) Transmission Case****■ NOTE**

- For the disassembling procedure from “Draining the Transmission Fluid” to “Step and Floor Seat”, refer to page 3-S18 to 3-S24.

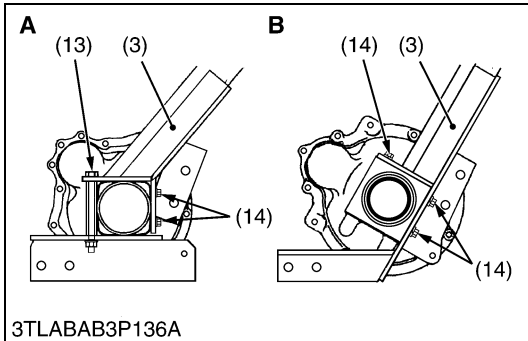
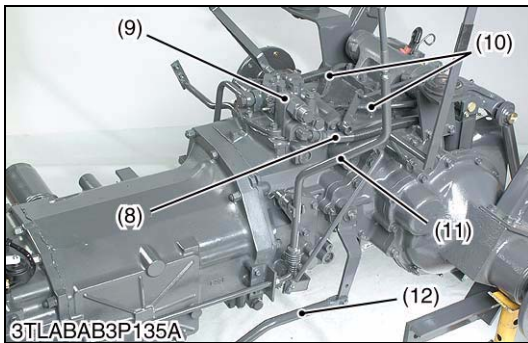
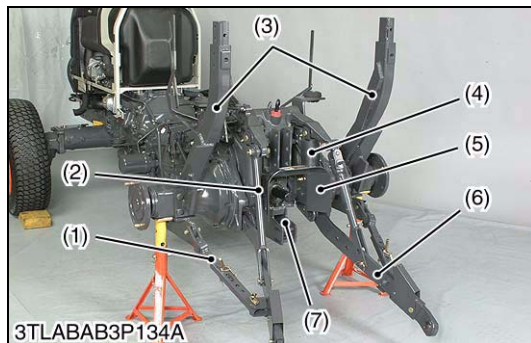
**Rear Wheel**

- Place disassembling stand under the transmission case, and support it with a jack.
- Remove the rear wheels.
- After removing the rear wheels, support it at both sides of rear axle by stands.

**(When reassembling)**

Tightening torque	Rear wheel mounting screw and nut	215 N-m 22 kgf-m 160 ft-lbs
	Rear wheel mounting stud bolt	98.1 to 112.8 N-m 10.0 to 11.5 kgf-m 72.3 to 83.2 ft-lbs

W1021882

**ROPS, 3 Point Linkages, Hydraulic Cylinders and Others**

- Remove the top link.
- Remove the lift rods (2), lower links (6) and check chains (1) as a unit.
- Remove the ROPS lower frames (3).
- Remove the PTO shaft cover (5).
- Remove the drawbar frame (7).
- Disconnect the hydraulic cylinder hoses (8) and return hoses (10) at the rear hydraulic block (9).
- Remove the two pins and remove the hydraulic cylinders (4).
- Remove the main gear shift lever (11).
- Disconnect the brake rods (12).

**(When reassembling)**

- Apply grease to the lower link pins and hydraulic cylinder pins.

Tightening torque	Lift arm pin mounting nut	77.5 to 90.2 N-m 7.9 to 9.2 kgf-m 57.1 to 66.5 ft-lbs
	Lift arm pin lock nut	62.8 to 72.6 N-m 6.4 to 7.4 kgf-m 46.3 to 53.5 ft-lbs
	Drawbar frame mounting screw (M12)	77.5 to 90.2 N-m 7.9 to 9.2 kgf-m 57.1 to 66.5 ft-lbs
	Drawbar frame mounting screw (M14)	167 to 196 N-m 17.0 to 20.0 kgf-m 123 to 145 ft-lbs
	Hydraulic cylinder hose	34.3 to 48.1 N-m 3.5 to 4.9 kgf-m 25.3 to 35.4 ft-lbs
	ROPS lower frame mounting screw	167 to 196 N-m 17.0 to 20.0 kgf-m 123 to 145 ft-lbs

- |                             |                            |
|-----------------------------|----------------------------|
| (1) Check Chain             | (9) Rear Hydraulic Block   |
| (2) Lift Rod                | (10) Return Hose           |
| (3) ROPS Lower Frame        | (11) Main Gear Shift Lever |
| (4) Hydraulic Cylinder      | (12) Brake Rod             |
| (5) PTO Shaft Cover         | (13) Screw (M14 × 155)     |
| (6) Lower Link              | (14) Screw (M14 × 30)      |
| (7) Drawbar Frame           | <b>A : L3130, L3430</b>    |
| (8) Hydraulic Cylinder Hose | <b>B : L3830, L4630</b>    |

W1142329

KiSC issued 02, 2007 A

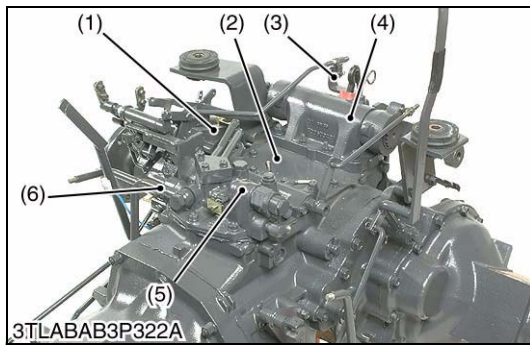

**Rear Hydraulic Block and Lift Arm Support**

1. Disconnect the draft control rod pin (3).
2. Remove the auxiliary valve (1), hoses and pipes.
3. Loosen the main delivery pipe support screw and disconnect the main delivery pipe (5) at the rear hydraulic block (4).
4. Remove the rear hydraulic block (4), cover (2) and lift arm support (3) as a unit.

**(When reassembling)**

- Apply liquid gasket (Three Bond 1208D or equivalent) to joint face of the differential case and cover (2).

Tightening torque	Joint bolt for main delivery pipe	49 to 69 N·m 5.0 to 7.0 kgf·m 36.1 to 50.6 ft·lbs
-------------------	-----------------------------------	---

- (1) Auxiliary Valve
- (2) Cover
- (3) Draft Control Rod Pin
- (4) Lift Arm Support
- (5) Rear Hydraulic Block
- (6) Main Delivery Pipe

W1022601



**Rear Axle**

1. Separate the rear axle case from brake case.

**(When reassembling)**

- Apply liquid gasket (Three Bond 1208D or equivalent) to joint face of the rear axle and brake case.

Tightening torque	Rear axle case mounting screw and nut	M10 screw and nut (7T)	48.1 to 55.9 N·m 4.9 to 5.7 kgf·m 35.4 to 41.2 ft·lbs
		Stud bolt	24.5 to 31.4 N·m 2.5 to 3.2 kgf·m 18.1 to 23.1 ft·lbs
		M10 nut (9T) (Except L3130, L3430)	60.8 to 70.6 N·m 6.2 to 7.2 kgf·m 44.9 to 52.1 ft·lbs
		M12 screw (Except L3130, L3430)	77.5 to 90.2 N·m 7.9 to 9.2 kgf·m 57.1 to 66.5 ft·lbs

W1022886



**Brake Case**

1. Remove the range gear shift lever and its fulcrum screw.
2. Remove the brake case mounting screws and nuts.
3. Separate the brake case, tapping the brake case lever lightly.

**(When reassembling)**

- Apply grease to the steel ball seats. (Do not grease excessively.)
- Apply liquid gasket (Three Bond 1208D or equivalent) to joint face of the brake case and transmission case.
- Be sure to apply liquid gasket to **A** position.
- Be sure to fix the brake cam and cam plate.
- Before installing the brake case to the transmission case, install the cam plate to the transmission case.

Tightening torque	Brake case mounting stud bolt	29.4 to 49.0 N·m 3.0 to 5.0 kgf·m 21.7 to 36.1 ft·lbs
	Brake case mounting screw and nut	77.5 to 90.2 N·m 7.9 to 9.2 kgf·m 57.1 to 66.5 ft·lbs
	Lever fulcrum screw	62.8 to 72.5 N·m 6.4 to 7.4 kgf·m 46.3 to 53.5 ft·lbs

W10194530



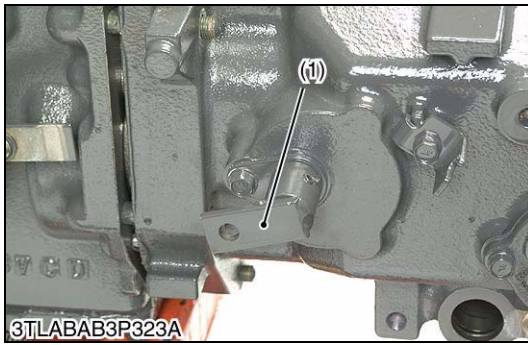

**Separating Mid Case and Transmission Case**

1. Remove the screw and pull the PTO shift rod (1).
2. Separate the mid case and transmission case after removing their mounting screws and nut.

**(When reassembling)**

- Confirm to insert the PTO shaft to PTO clutch firmly, turning the PTO shaft.
- Confirm to insert the front wheel drive shaft to coupling firmly.
- Apply liquid gasket (Three Bond 1208D or equivalent) to joint face of the mid case and transmission case.

Tightening torque	Mid case and transmission case mounting screw	77.5 to 90.2 N-m 7.9 to 9.2 kgf-m 57.1 to 66.5 ft-lbs
	Mid case and transmission case mounting nut	102.9 to 117.6 N-m 10.5 to 12.0 kgf-m 75.9 to 86.8 ft-lbs
	Mid case and transmission case mounting stud bolt	39.2 to 49.0 N-m 4.0 to 5.0 kgf-m 28.9 to 36.2 ft-lbs



(1) PTO Shift Rod

W1023310

**PTO Gear Shaft**

1. Remove the gear (6) and external snap ring (5).
2. Remove the PTO gear shaft (8), shift fork (9) and shifter (3).

- |                        |                    |
|------------------------|--------------------|
| (1) Needle Bearing     | (6) 27T Gear       |
| (2) 30T Gear           | (7) Needle Bearing |
| (3) Shifter            | (8) PTO Gear Shaft |
| (4) Hub                | (9) Shift Fork     |
| (5) External Snap Ring |                    |

W1057984

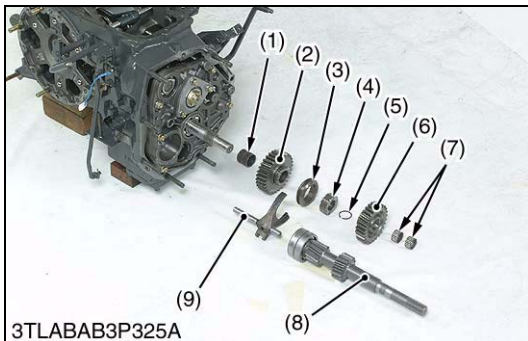

**Pinion Bearing Cover**

1. Remove the stake of lock nut (5).
2. Lock the turning of spiral bevel pinion and remove the lock nut (5).
3. Remove the pinion bearing case mounting screws.
4. Take out the pinion bearing cover (4) and shims (1).

**(When reassembling)**

- Make sure of the number of shims in the pinion bearing case.
- Replace the lock nut (5) with a new one, and stake the lock nut firmly after installing the parts on the shaft.

Tightening torque	Lock nut	147 to 196 N-m 15 to 20 kgf-m 108 to 145 ft-lbs
	Pinion bearing case mounting screw	39.2 to 44.1 N-m 4.0 to 4.5 kgf-m 28.9 to 32.5 ft-lbs

- |                               |                          |
|-------------------------------|--------------------------|
| (1) Shim                      | (4) Pinion Bearing Cover |
| (2) Pinion Bearing Case       | (5) Lock Nut             |
| (3) Spiral Bevel Pinion Shaft |                          |

W1022792

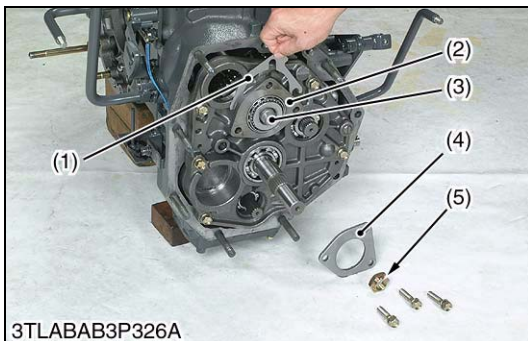

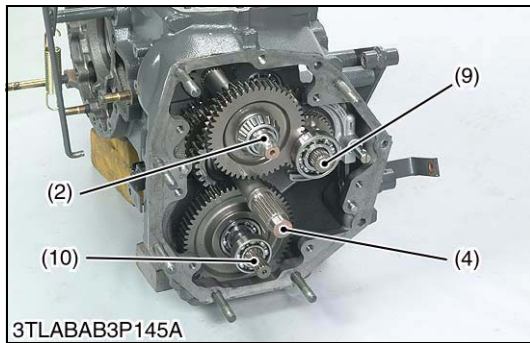
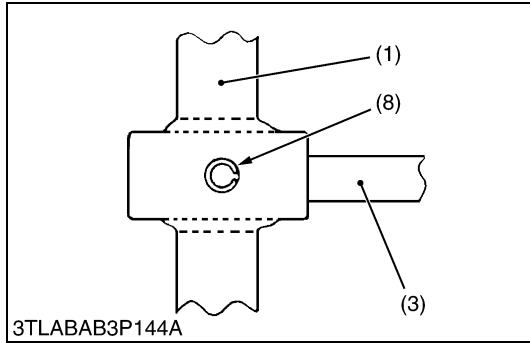
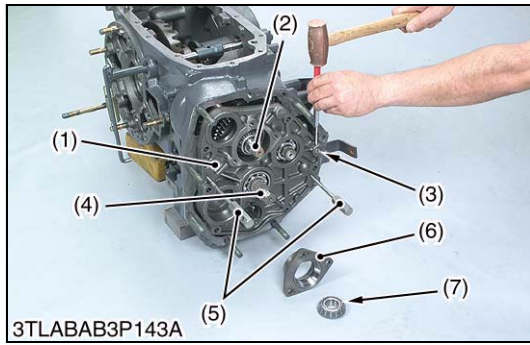

### Transmission Bearing Holder

1. Remove the transmission bearing holder mounting screws.
2. Tap out the spring pin (8) on the shift fork rod (3).
3. Jack up the bearing holder (1) by using the two jack screws (5) until the taper roller bearing (7) can be removed.

■ **NOTE**

- **Jack up the bearing holder while hitting the two shafts (2) (4) by copper hammer or soft hammer.**

4. Jack up more and remove the transmission bearing holder (1).

**(When reassembling)**

- Tap in the transmission bearing holder with soft hammer until contact to transmission case, and then tighten the screws to specified torque.
- Tap in the spring pin (8) so that its split portion may face forward. (Refer to figure.)

Tightening torque	Transmission bearing holder mounting screw	48.1 to 55.9 N·m 4.9 to 5.7 kgf·m 35.5 to 41.2 ft-lbs
-------------------	--	---

- |   |                              |
|---|------------------------------|
| (1) Transmission Bearing Holder         | (6) Pinion Bearing Case      |
| (2) Spiral Bevel Pinion Shaft           | (7) Taper Roller Bearing     |
| (3) Shift Fork Rod for Range Gear Shift | (8) Spring Pin               |
| (4) PTO Drive Shaft                     | (9) Range Gear Shaft         |
| (5) Jack Screw                          | (10) Front Wheel Drive Shaft |

W1023062

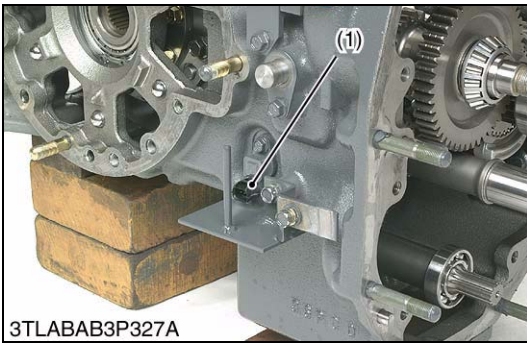

3TLABAB3P327A

**Shaft Assemblies**

1. Remove the traveling speed sensor (1).
2. Take out the spiral bevel pinion shaft assembly (4), range gear shaft assembly (5) and PTO drive shaft assembly (3).
3. Take out the front wheel drive shaft (2).

- |                               |                       |
|-------------------------------|-----------------------|
| (1) Traveling Speed Sensor    | (9) Needle Bearing    |
| (2) Front Wheel Drive Shaft   | (10) 35T Gear         |
| (3) PTO Drive Shaft           | (11) 17T Gear         |
| (4) Spiral Bevel Pinion Shaft | (12) 20T-49T Gear     |
| (5) Range Gear Shaft          | (13) Shifter          |
| (6) Shift Fork                | (14) 29T-32T Gear     |
| (7) Shift Fork                | (15) 24T Shifter Gear |
| (8) 17T Gear                  |                       |

W1024207

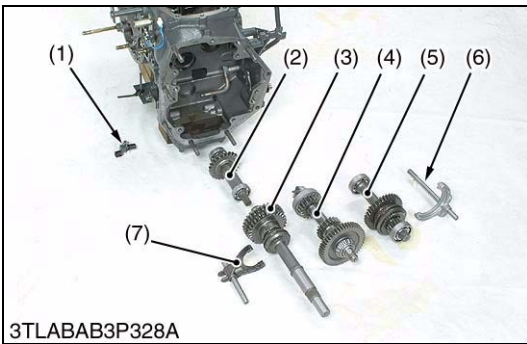

3TLABAB3P328A

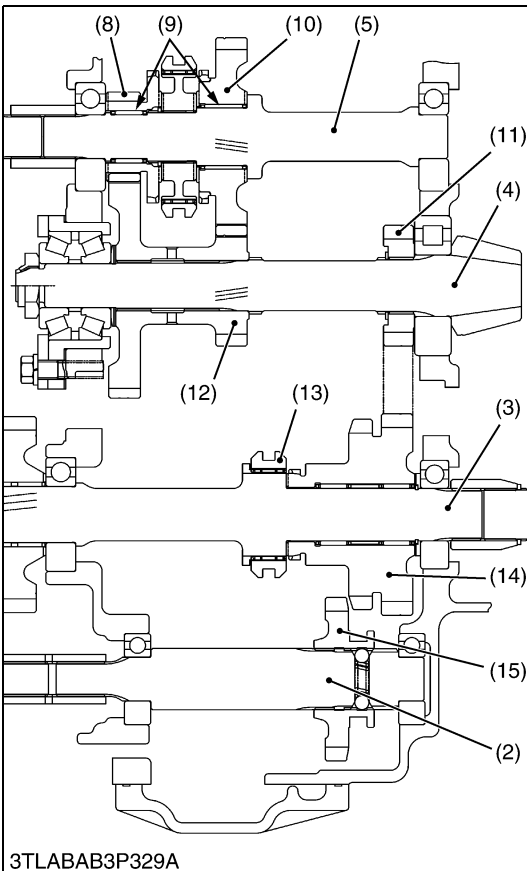

3TLABAB3P329A

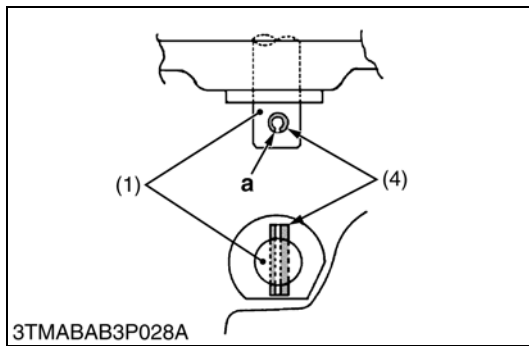
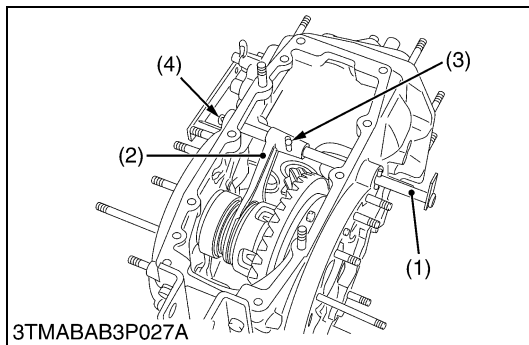

### Differential Lock Shift Fork

1. Tap out the left side spring pin (4).
2. Remove the cotter pin and take out the clevis pin (3).
3. Draw out the differential lock fork shaft (1) and take out the differential lock shift fork (2).

#### (When reassembling)

- Apply grease to the left and right oil seals on the transmission case.
- Insert the clevis pin (3) from the top and install the washer and cotter pin.
- Tap in the spring pin (4) so that its split portion **a** may face outward as shown in the figure.

- (1) Differential Lock Fork Shaft  
 (2) Differential Lock Shift Fork  
 (3) Clevis Pin  
 (4) Spring Pin

**a : Split Portion**

W10225860

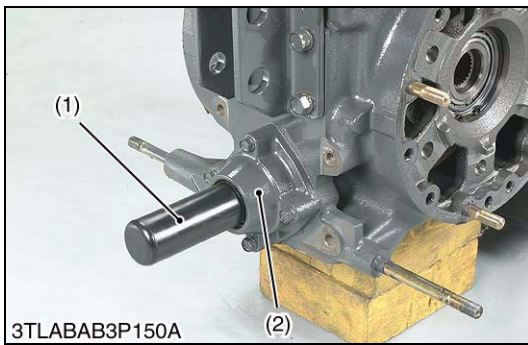

**PTO Shaft**

1. Remove the PTO shaft cover.
2. Remove the bearing case mounting screws, and draw out the PTO shaft (1) with bearing case (2).
3. Remove the internal snap ring (3).
4. Top out the PTO shaft (1) to the front.

**(When reassembling)**

- If the lock nut (6) was removed, replace it with a new one. After replacing, be sure to stake it firmly.
- Install the slinger (7) firmly.
- Apply grease to the oil seal (4) and install it, noting its direction.

Tightening torque	Lock nut	147 to 196 N·m 15 to 20 kgf·m 108 to 145 ft·lbs
	Bearing case mounting screw	23.5 to 27.5 N·m 2.4 to 2.8 kgf·m 17.4 to 20.3 ft·lbs

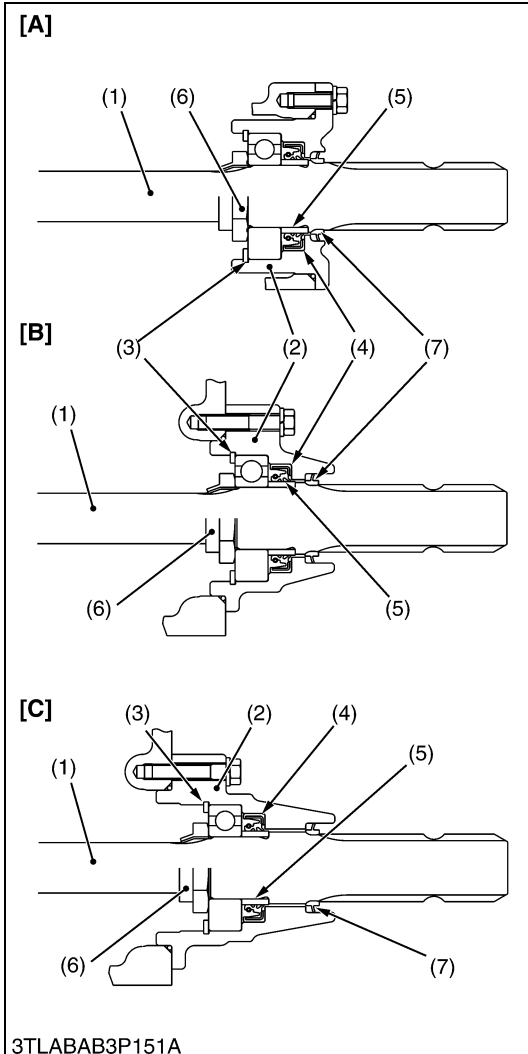

- (1) PTO Shaft
- (2) Bearing Case
- (3) Internal Snap Ring
- (4) Oil Seal
- (5) Oil Seal Collar
- (6) Lock Nut
- (7) Slinger

- [A] L3130, L3430
- [B] L3830, L4630
- [C] L5030

W10242030

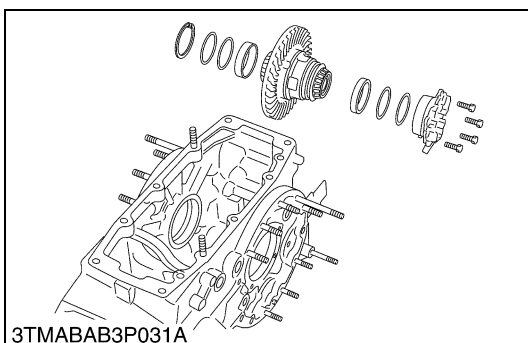

**Differential Gear Assembly**

1. Remove the differential support, noting the number of left shims.
2. Take out the differential gear assembly, noting the number of right shims.

**(When reassembling)**

- Check the spiral bevel gear for wear or damage. If it is no longer serviceable, replace it. Then, also replace the spiral bevel pinion.
- Use same number of shims as before disassembling.

Tightening torque	Differential support mounting screw	48.1 to 55.9 N·m 4.9 to 5.7 kgf·m 35.4 to 41.2 ft·lbs
-------------------	-------------------------------------	---

W10245370



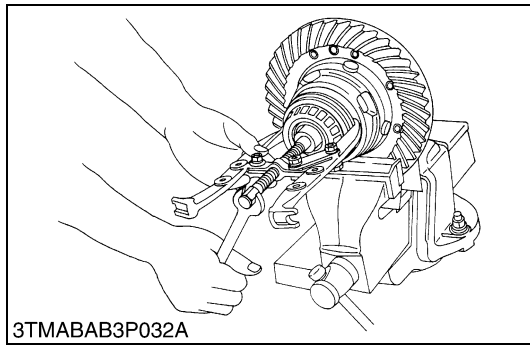

3TMABAB3P032A

### **Bearing and Differential Lock Shifter**

1. Secure the differential gear in a vise.
2. Remove the differential lock shifter and taper roller bearing as a unit with a puller.

W10246640

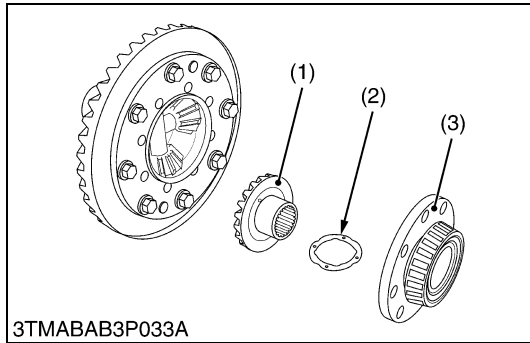

3TMABAB3P033A

### **Differential Case Cover and Differential Side Gear**

1. Remove the differential case cover (3).
2. Remove the differential side gear (1) and differential side gear washer (2).

#### **(When reassembling)**

- Apply molybdenum disulfide (Three Bond 1901 or equivalent) to the inner circumferential surface of the differential side gear boss.

Tightening torque	Differential case cover mounting screw	48.1 to 55.9 N·m 4.9 to 5.7 kgf·m 35.4 to 41.2 ft·lbs
-------------------	--	---

- (1) Differential Side Gear  
(2) Differential Side Gear Washer

(3) Differential Case Cover

W10247220

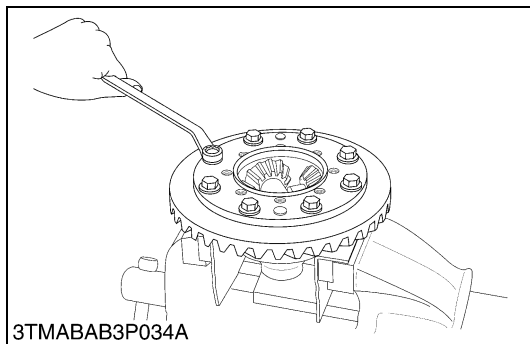

3TMABAB3P034A

### **Spiral Bevel Gear**

1. Remove the spiral bevel gear.

#### **(When reassembling)**

- Check the spiral bevel gear for wear or damage. If it is no longer serviceable, replace it. Then, also replace the spiral bevel pinion shaft.
- Apply liquid lock (Three Bond 1372 or equivalent) to the spiral bevel gear UBS screws.

Tightening torque	Spiral bevel gear UBS screw	68.6 to 88.3 N·m 7.0 to 9.0 kgf·m 50.6 to 65.1 ft·lbs
-------------------	-----------------------------	---

W10249330

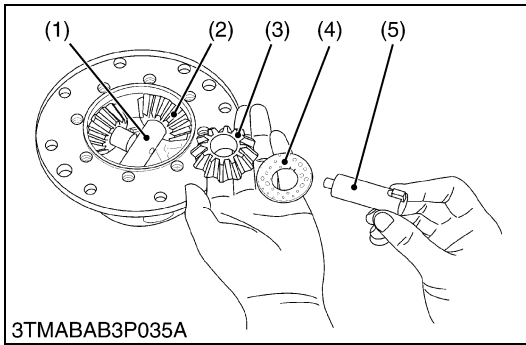

3TMABAB3P035A

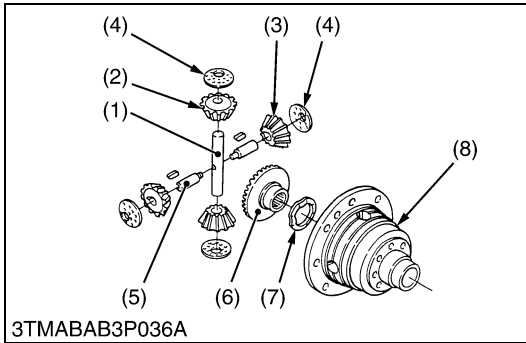

3TMABAB3P036A

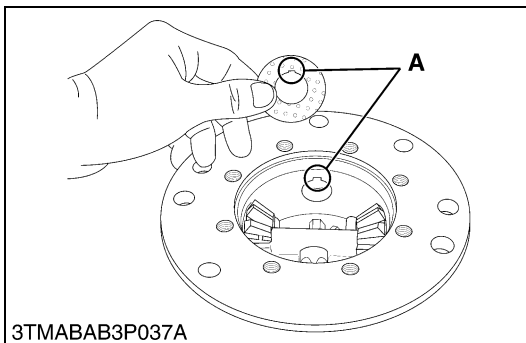

3TMABAB3P037A

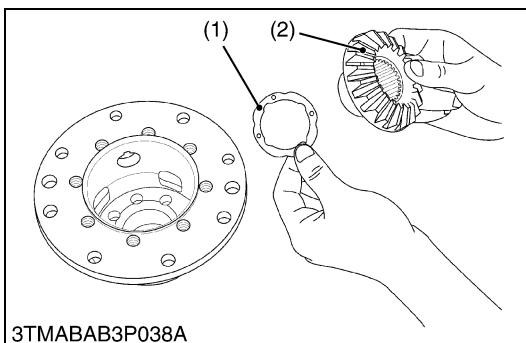

3TMABAB3P038A

### Differential Pinion Shaft and Differential Pinion

1. Draw out the differential pinion shaft 2 (5), and take out the differential pinion (3) and differential pinion washer (4).
2. Draw out the differential pinion shaft (1), and take out the differential pinion (2) and differential pinion washer.

#### NOTE

- Arrange the parts to know their original position.

#### (When reassembling)

- Check the differential pinions (2) and (3), and pinion shaft (1) and (5) for excessive wear. If these parts are damaged or excessively worn, replace their parts they are in mesh with, or they sliding on.
- Apply molybdenum disulfide (Three Bond 1901 or equivalent) to the inner circumferential surface of the differential pinions.
- Install the parts to their original position.
- Install the differential pinion washer (4), noting its groove position.

- (1) Differential Pinion Shaft  
 (2) Differential Pinion  
 (3) Differential Pinion  
 (4) Differential Pinion Washer  
 (5) Differential Pinion Shaft 2

- (6) Differential Side Gear  
 (7) Differential Side Gear Washer  
 (8) Differential Case

**A : Fit Groove**

W10250420

### Differential Side Gear

1. Take out the differential side gear (2) and differential side gear washer (1).

#### (When reassembling)

- Check the thrust and bearing surface of both differential side gears (2). If they are worn or damaged, bores in the differential case may also be damaged. Be sure to replace their parts.

- (1) Differential Side Gear Washer      (2) Differential Side Gear

W10252580

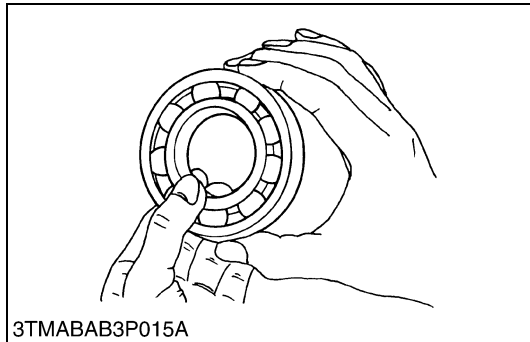

**(3) Servicing****(A) Bearing, Gear and Shaft**

3TMABAB3P015A

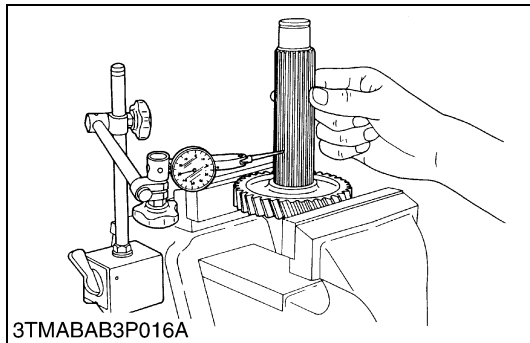

3TMABAB3P016A

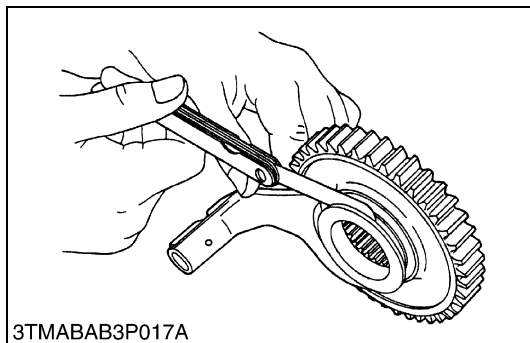

3TMABAB3P017A

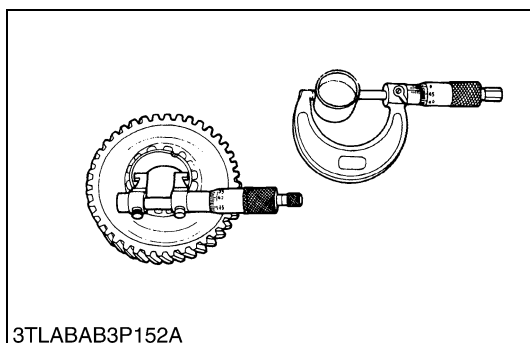

3TLABAB3P152A

**Checking Bearing**

1. Hold the inner race, and push and pull the outer race in all directions to check for wear and roughness.
2. Apply transmission fluid to the bearing, and hold the inner race. Then turn the outer race to check rotation.
3. If there is any defect, replace it.

W10222940

**Clearance between Gear and Spline**

1. Secure the gear with a vise.
2. Set a dial indicator (lever type) with its finger on the spline.
3. Move the shaft to measure the clearance.
4. If the clearance exceeds the allowable limit, replace them.

Clearance between gear and spline	Factory spec.	0.030 to 0.078 mm 0.0018 to 0.00307 in.
	Allowable limit	0.2 mm 0.008 in.

W10258480

**Clearance between Shift Fork and Shift Gear Groove**

1. Place for in the groove to check clearance with feeler gauge.
2. If the clearance exceeds allowable limit, replace.

Clearance between shift fork and shift gear groove	Factory spec.	0.20 to 0.40 mm 0.008 to 0.016 in.
	Allowable limit	0.8 mm 0.031 in.

W10269970

**Clearance between Gear and Shaft**

1. Measure the shaft O.D. (rubbing surface).
2. Measure the gear I.D. (rubbing surface).
3. Measure the O.D. of the two needles installed diagonally in the needle bearing.
4. Calculate the clearance  
(Clearance = Gear I.D. - {(2 × needle O.D.) + shaft O.D.})
5. If the clearance exceeds the allowable limit, replace them.

Clearance between gear and shaft	Factory spec.	0.021 to 0.054 mm 0.00083 to 0.00213 in.
	Allowable limit	0.1 mm 0.004 in.

W1026299

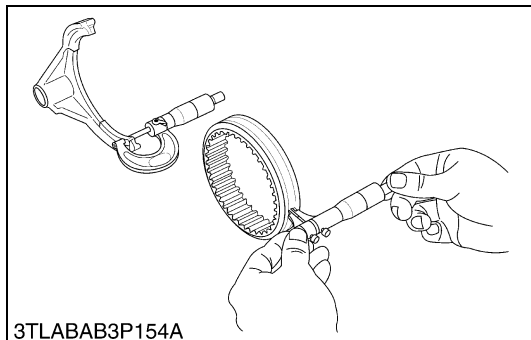
**(B) Synchronized Gear**

3TLABAB3P154A

**Clearance between Shift Fork and Shifter Groove**

1. Measure the width of shift fork.
2. Measure the shifter groove width, and calculate the clearance.
3. If the clearance exceeds the allowable limit, replace them.

Clearance between shift fork and shifter groove	Factory spec.	Shuttle F-R	0.20 to 0.45 mm 0.0079 to 0.0177 in.
		Other	0.15 to 0.40 mm 0.0059 to 0.0157 in.
	Allowable limit	Shuttle F-R	0.80 mm 0.031 in.
		Other	0.80 mm 0.031 in.

W1020704

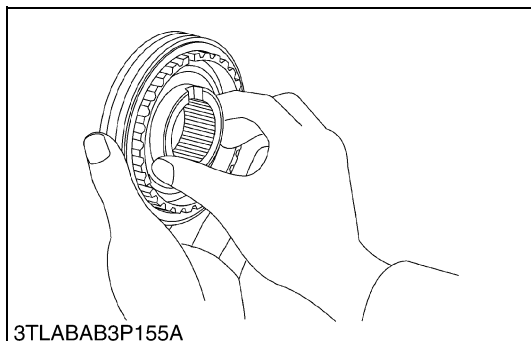

3TLABAB3P155A

**Checking Contact between Coupling and Shifter**

1. Check to see if there is flaw or wear on the spline of the coupling and shifter, and the key groove on the coupling.
2. Engage the shifter with the coupling, and check that they slide smoothly.
3. Similarly, check that there is any flaw or wear on the gear splines.
4. If there is any defect, replace them.

W1020860

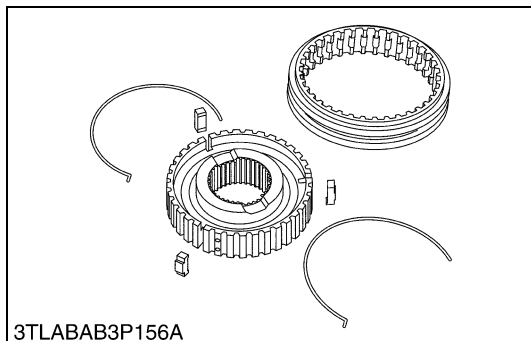

3TLABAB3P156A

**Flaw on Synchronizer Key and Spring**

1. Check the projection in the center of the synchronizer key for wear.
2. Check the spring for fatigue or wear on the area where the spring contacts with the keys.
3. If there is any defect, replace them.

W1021026

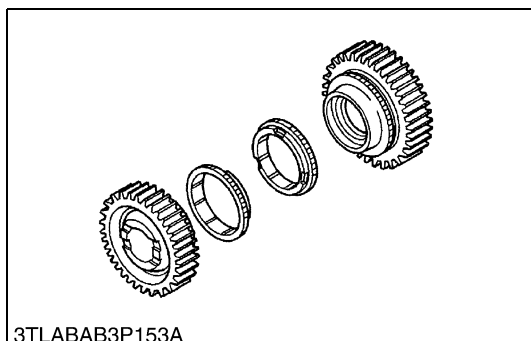

3TLABAB3P153A

**Side Clearance between Synchronizer Ring and Gear (In Contact)**

1. Press the synchronizer ring against the tapered portion of the gear, and measure the side clearance.
2. Apply thin film of red lead to the tapered portion, press the ring against it by hand, rub them together a few times, and check the contact.
3. Check the tooth surface and key grooves of the ring for wear.
4. If the side clearance exceeds the allowable limit or if there is any defect, replace the synchronizer ring.

Side clearance	Allowable limit	0.35 mm 0.0138 in.
----------------	-----------------	-----------------------

Contact condition of tapered portion	Allowable limit	More than 80 %
--------------------------------------	-----------------	----------------

W1026696

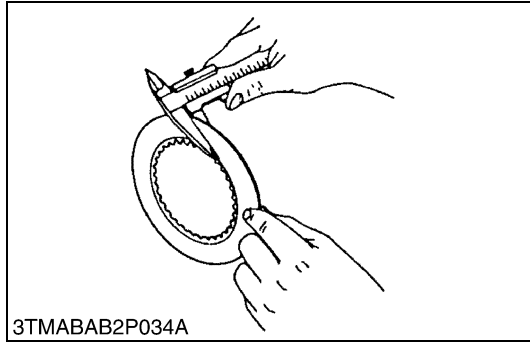
**(C) PTO Clutch****PTO Clutch Disc Wear**

1. Measure the thickness of PTO clutch disc with vernier calipers.
2. If the thickness is less than the allowable limit, replace it.

Thickness of PTO clutch disc	Factory spec.	1.70 to 1.90 mm 0.067 to 0.075 in.
	Allowable limit	1.55 mm 0.061 in.

W1021195

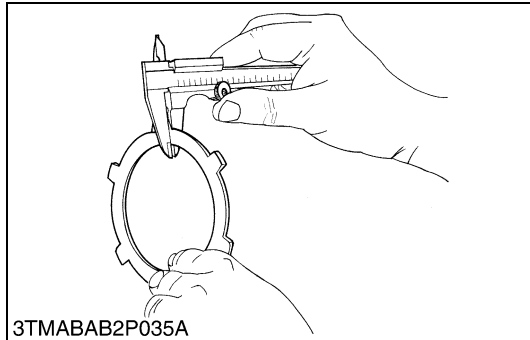
**PTO Steel Plate Wear**

1. Measure the thickness of PTO steel plate with vernier calipers.
2. If the thickness is less than the allowable limit, replace it.

Thickness of PTO steel plate	Factory spec.	1.15 to 1.25 mm 0.045 to 0.049 in.
	Allowable limit	1.10 mm 0.043 in.

W1021446

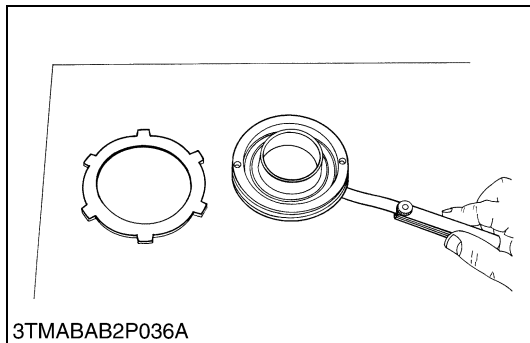
**Flatness of PTO Piston and PTO Steel Plate**

1. Place the part on a surface plate.
2. Check it unable to insert a feeler gauge (allowable limit size) underneath it at least four points.
3. If the gauge can be inserted, replace it.

Flatness of PTO piston	Allowable limit	0.15 mm 0.006 in.
------------------------	-----------------	----------------------

Flatness of PTO steel plate	Allowable limit	0.30 mm 0.012 in.
-----------------------------	-----------------	----------------------

W1021557

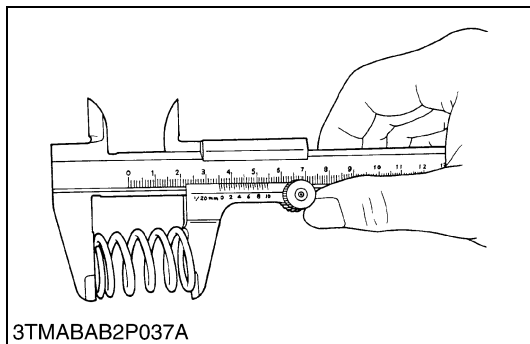
**Piston Return Spring Free Length**

1. Measure the free length of spring with vernier calipers.
2. If the measurement is less than the allowable limit, replace it.

PTO return spring free length	Factory spec.	40.5 mm 1.59 in.
	Allowable limit	37.5 mm 1.48 in.

PTO brake spring free length	Factory spec.	20.3 mm 0.80 in.
	Allowable limit	18.0 mm 0.71 in.

W1021677

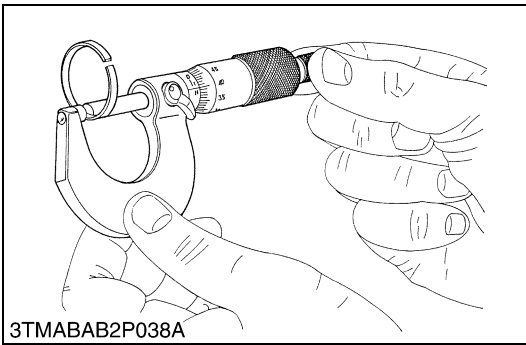

**Thickness of Seal Ring**

1. Measure the thickness of seal rings (1) with an outside micrometer.
2. If the measurement is less than the allowable limit, replace it.

Thickness of seal ring	Factory spec.	2.45 to 2.50 mm 0.096 to 0.098 in.
	Allowable limit	2.0 mm 0.0079 in.

(1) Seal Ring

W1021804

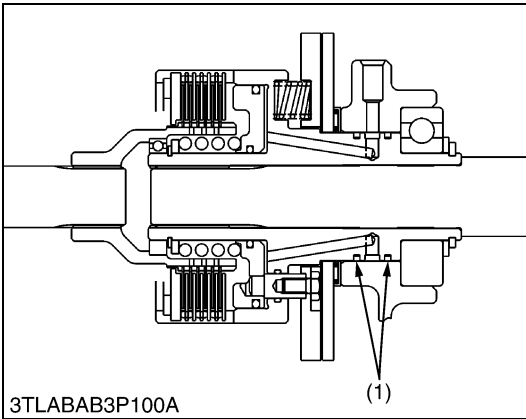

**(D) Differential Gears**

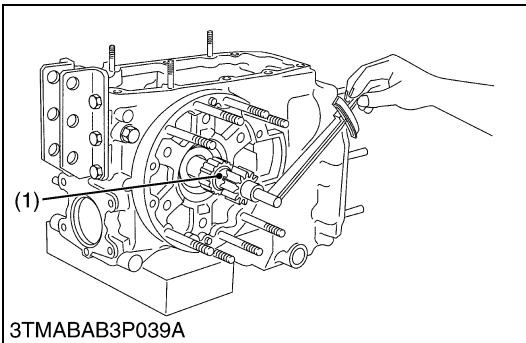

**Spiral Bevel Gear Turning Torque**

■ **NOTE**

- It is necessary to adjust the spiral bevel gear turning torque, when replacing the differential gears, transmission case or other relative parts.

1. Assemble the differential gears to transmission case. At this time, install the some shims (3) to the spiral bevel gear side.
2. Check the turning torque by using turning torque tool (1).  
Turning Torque Tool : Weld socket on the brake shaft  
(Brake shaft Part No. TA040-26710)
3. Add or reduce the thickness of shims (3) to make the specified turning torque.
4. After getting the specified turning torque, divide the thickness of shims to left and right side.
5. Assemble the transmission case and adjust the backlash and tooth contact with spiral bevel pinion. (See next page.)

Turning torque of 37T spiral bevel gear	Factory spec.	3.92 to 6.37 N·m 0.40 to 0.65 kgf·m 2.89 to 4.70 ft·lbs
---	---------------	---

- (1) Turning Torque Tool  
(2) 37T Spiral Bevel Gear

- (3) Adjusting Shim  
(4) Differential Support

W10277520

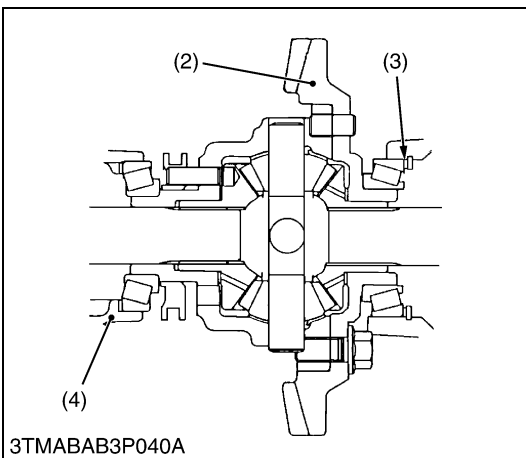

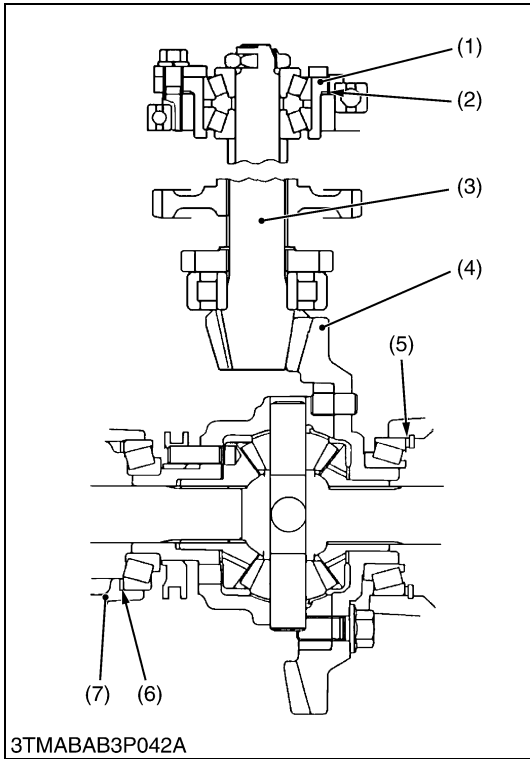
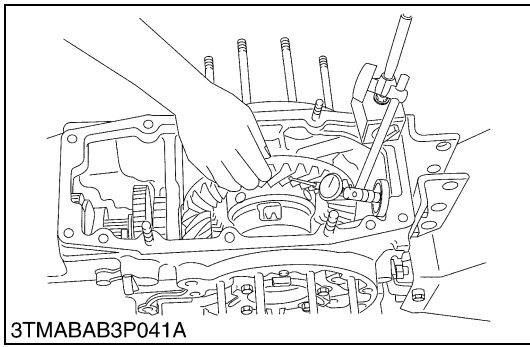

**Backlash and Tooth Contact between Spiral Bevel Gear and Spiral Bevel Pinion Shaft**

1. Set the dial indicator (lever type) with its finger on the tooth surface.
2. Measure the backlash by fixing the spiral bevel pinion shaft (3) and moving the spiral bevel gear (4) by hand.
3. When the backlash is too large, decrease the number of shims (6) in the side of the spiral bevel gear, and insert the shims (5) of the same thickness as the removed ones to the opposite side. When the backlash is too small, do the opposite way to increase backlash.
4. Adjust the backlash properly by repeating the above procedure.
5. Apply red lead lightly over several teeth at three positions equally spaced on the spiral bevel gear.
6. Turn the spiral bevel pinion shaft, while pressing a wooden piece against the periphery on the spiral bevel gear.
7. Check the tooth contact. If not proper, adjust according to the instructions below.

Backlash between spiral bevel gear and spiral bevel pinion shaft	Factory spec.	0.15 to 0.30 mm 0.006 to 0.012 in.
	Allowable limit	0.4 mm 0.016 in.

**(Reference)**

- Thickness of shims (2) :  
0.1 mm (0.004 in.) 0.2 mm (0.008 in.) 0.5 mm (0.020 in.)
- Thickness of shims (5) :  
0.4 mm (0.016 in.) 0.7 mm (0.028 in.) 1.0 mm (0.039 in.)  
0.5 mm (0.020 in.) 0.8 mm (0.031 in.) 1.2 mm (0.047 in.)  
0.6 mm (0.024 in.) 0.9 mm (0.035 in.) 1.4 mm (0.055 in.)
- Thickness of shims (6)  
0.4 mm (0.016 in.) 0.8 mm (0.031 in.) 1.2 mm (0.047 in.)  
0.6 mm (0.024 in.) 1.0 mm (0.039 in.) 1.6 mm (0.063 in.)

- (1) Pinion Bearing Case
- (2) Shim
- (3) Spiral Bevel Pinion
- (4) Spiral Bevel Gear
- (5) Shim
- (6) Shim
- (7) Differential Support

W10279260

More than 35 % red lead contact area on the gear tooth surface.  
The center of tooth contact at 1/3 of the entire width from the small end.

**(A) Proper Contact**

W10187470

Replace the adjusting shim (2) with thicker one to move the spiral bevel pinion shaft backward.

For move the spiral bevel gear rightward, reduce right side shim (5) and add shim (6) of the same thickness as the right side to left side.

**(B) Shallow Contact**

**(C) Heel Contact**

W10189000

Replace the shim (2) with a thinner one to move the spiral bevel pinion shaft forward.

For move the spiral bevel gear leftward, reduce left side shim (6) and add shim (5) of the same thickness as the left side to right side.

Repeat above until the proper tooth contact and backlash are achieved.

**(D) Deep Contact**

**(E) Toe Contact**

W10189730

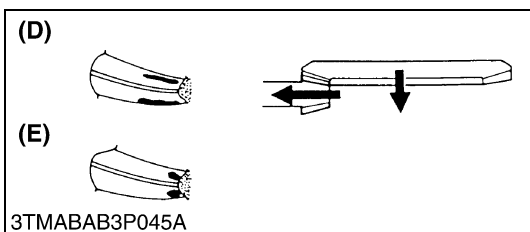
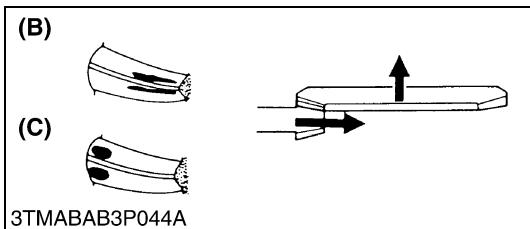
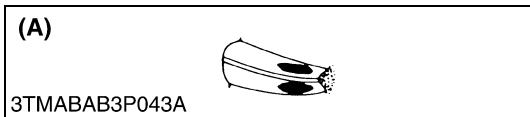

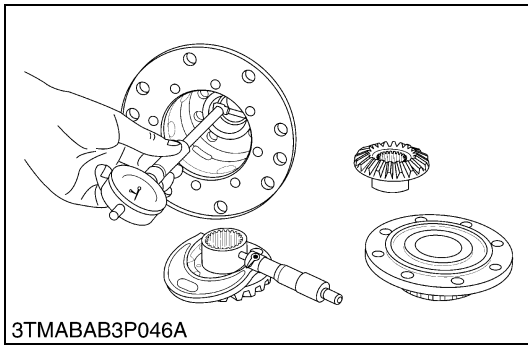

### **Clearance between Differential Case Bore (Differential Case Cover Bore) and Differential Side Gear Boss**

1. Measure the bore I.D. of the differential case and differential case cover.
2. Measure the differential side gear boss O.D. and calculate the clearance.
3. If the clearance exceeds the allowable limit, replace them.

Clearance between differential case bore and differential side gear boss	Factory spec.	0.050 to 0.151 mm 0.00197 to 0.00594 in.
	Allowable limit	0.35 mm 0.0138 in.

Differential case bore I.D.	Factory spec.	40.500 to 40.550 mm 1.59449 to 1.59646 in.
Differential side gear boss O.D.	Factory spec.	40.388 to 40.450 mm 1.59008 to 1.59252 in.

Clearance between differential case cover bore and differential side gear boss	Factory spec.	0.050 to 0.151 mm 0.00197 to 0.00594 in.
	Allowable limit	0.35 mm 0.0138 in.

Differential case cover bore I.D.	Factory spec.	40.500 to 40.550mm 1.59449 to 1.59646 in.
Differential side gear boss O.D.	Factory spec.	40.388 to 40.450 mm 1.59008 to 1.59252 in.

W10284030

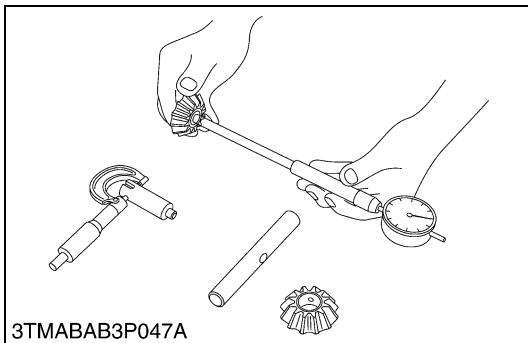

### **Clearance between Differential Pinion Shaft and Differential Pinion**

1. Measure the differential pinion shaft O.D.
2. Measure the differential pinion I.D. and calculate the clearance.
3. If the clearance exceed the allowable limit, replace them.

Clearance between differential pinion shaft and differential pinion	Factory spec.	0.060 to 0.102 mm 0.00236 to 0.00402 in.
	Allowable limit	0.25 mm 0.0098 in.

Differential pinion shaft O.D.	Factory spec.	19.959 to 19.980 mm 0.78579 to 0.78661 in.
Differential pinion I.D.	Factory spec.	20.040 to 20.061 mm 0.78898 to 0.78980in.

W10287600

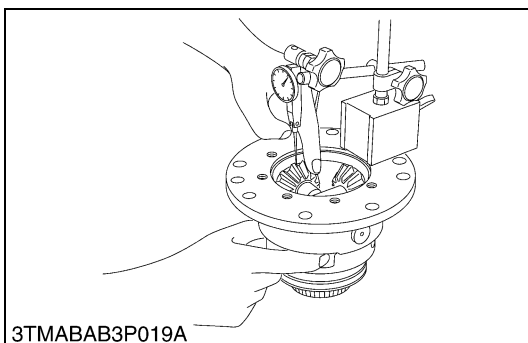

### **Backlash between Differential Pinion and Differential Side Gear**

1. Set a dial indicator (lever type) on the tooth of the differential pinion.
2. Hold the differential side gear and move the differential pinion to measure the backlash.
3. If the measurement is not within the factory specifications, adjust with the differential side gear washer.

Backlash between differential pinion and differential side gear	Factory spec.	0.15 to 0.30 mm 0.0059 to 0.0118 in.
	Allowable limit	0.4 mm 0.016 in.

### **(Reference)**

- Thickness of differential side gear washer :  
1.5 mm (0.059 in.) 1.7 mm (0.067 in.)  
1.6 mm (0.063 in.)

W10289200



## [2] GLIDE SHIFT TRANSMISSION (GST) MODEL

### (1) Checking and Adjusting

#### (A) Electrical Adjusting [GST Fine-adjustment with Electronic Instrument Panel (IntelliPanel)]

##### ■ NOTE

- Before executing the following fine-adjustment, refer to “Testing, Setting and Adjusting by Electronic Instrument Panel” of an Electrical System. (Refer to page 9-S12.)  
The fine-adjustment function is a function to update the data of the memory device in the ECU when a sensor, a valve, and an electronic instrument panel which relates to the GST system are repaired or are re-installed. There are three kinds of fine-adjustment functions in the GST system.

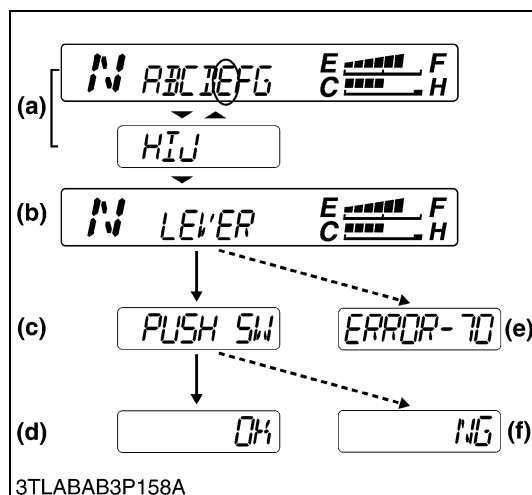

#### GST Lever Sensor Fine-adjustment

##### (Setting the GST lever's neutral position with its sensor)

##### ■ IMPORTANT

- As for this fine-adjustment, be sure to set it correctly because the set state becomes the standard of the control thereafter.

##### ■ NOTE

- When the GST lever sensor, the ECU or the electronic instrument panel is replaced, this adjustment is required.
1. Set the GST shift lever to **Neutral** position.
  2. Push down both the display mode switch (2) and the travel speed switch (3) at once, continue holding switches, and then turn the main switch to **ON** position.
  3. The “**Mode Selection Display**” (a) is indicated on the LCD (1). And release the switches.
  4. Press the display mode switch (2) to move the flashing part, and flash the “**E**”.
  5. Hold down the display mode switch (2) for more than 2 seconds at this condition, and the buzzer rings and Mode **E** is selected.
  6. “**LEVER**” is displayed (b) and “**PUSH SW**” is displayed (c) for five seconds.
  7. Hold down the display mode switch for more than 2 seconds. (This preserve the adjusted value to the ECU.)
  8. “**OK**” is displayed (d) on LCD screen to tell that preserving to ECU has been made correctly. Turn off the main switch to end the mode.
  9. If “**NG**” is displayed (f), it means the preserving has not been made correctly (4). Turn off the main switch and repeat the procedure.
  10. If “**LEVER**” is displayed (b) first and then “**ERROR-70**” shows up (e), it means the lever sensor voltage is out of specification. In this case;
    - Check to see that GST lever is at the **Neutral** position.
    - Check the lever sensor voltage in the Test Mode (Mode “**A**”) (see page 9-S13). If out of specification, replace the sensor itself.

- (1) Liquid Crystal Display (LCD)
- (2) Display Mode Switch
- (3) Travel Speed Switch

- (a) Mode Selection Display
- (b) Information Display
- (c) Adjusting Display
- (d) Correct Preserving Display
- (e) Error Display
- (f) Incorrect Preserving Display

W1029305

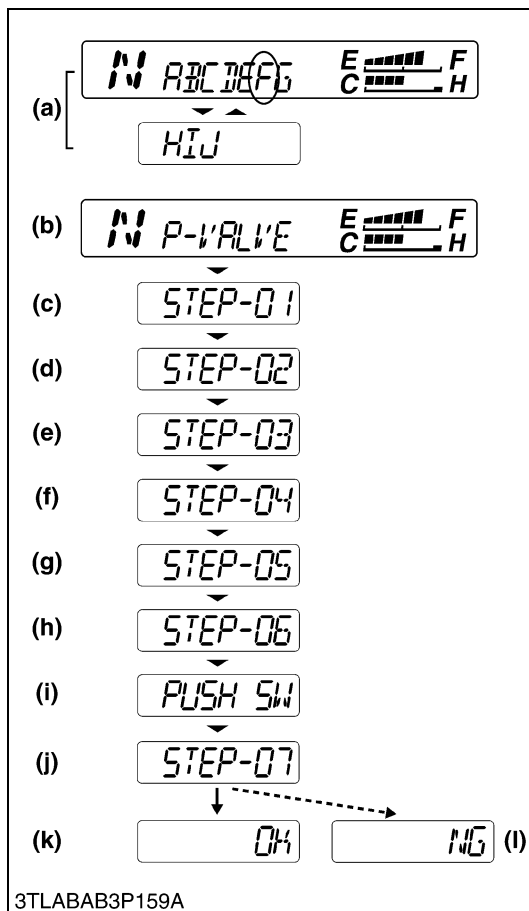

### GST Valve Fine-adjustment

#### (Setting the function of proportional reducing valve)

##### ■ NOTE

- When the ECU or GST valve is replaced, this adjustment is required.

1. Push down both the display mode switch and the travel speed switch at once, continue holding switches, and then start the engine.
2. Select Mode **F** by the procedure from 3 to 5 which has been described to previous page.
3. “**P-VALVE**” is displayed **(b)** and **STEP-01** **(c)** is displayed the three seconds after.

##### ■ NOTE

- To make this adjustment, follow these steps in the exact order described. (Otherwise the switch does not work to go to next step. At “STEP-01” and “STEP-03”, however, the next step can be moved without their settings.)
  - Push the display mode switch to move to the next step.
4. **STEP-01** **(c)** : Release parking brake.
  5. **STEP-02** **(d)** : Set the engine speed at 1000 to 1400 min<sup>-1</sup> (rpm).
  6. **STEP-03** **(e)** : Set front tires straight ahead.
  7. **STEP-04** **(f)** : Operate the speed selection lever (GST lever) as follows ; disengaged the clutch, select “**forward**” with the shuttle lever, and shift the GST lever from 1 thru 12 several times. Set the GST lever at the positions other than neutr1.
  8. **STEP-05** **(g)** : Set the GST lever to **Neutral** position.
  9. **STEP-06** **(h)** : Set shuttle lever to forward and engage clutch.
  10. **PUSH SW** **(i)** : Push the display mode switch for more than three seconds.
  11. **STEP-07** **(j)** : To preform this function the operator must be seated on the tractor.  
After a short delay the tractor will begin to move slowly. And then, after it moves a little, the tractor stops automatically. (Fine-adjustment is being executed.)
  12. **OK** is displayed **(k)** : The setting has been preserved correctly to the ECU.
  13. **NG** is displayed **(l)** : The setting has not been correctly saved in the ECU. Repeat the entire procedure.

(a) Mode Selection Display

(b) Information Display

(c) Setting Display-1

(d) Setting Display-2

(e) Setting Display-3

(f) Setting Display-4

(g) Setting Display-5

(h) Setting Display-6

(i) Adjusting Display

(j) Setting Display-7

(k) Correct Preserving Display

(l) Incorrect Preserving Display

W1029611

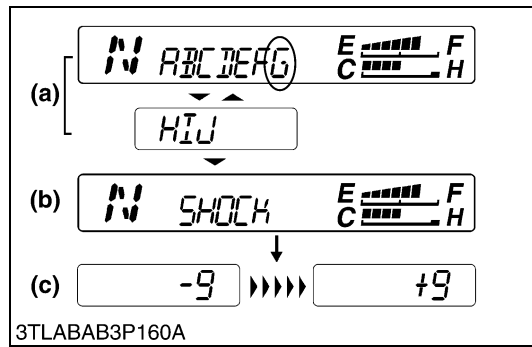

### **GST Shift Shock Fine-adjustment Mode** **(Adjusting the clutch engaging interval)**

#### ■ NOTE

- When the sense of shifting shock is not suitable, shifting shock can be changed by this adjustment.

1. Push down both the display mode switch and the travel speed switch at once, continue holding switches, and then start the engine.
2. Select Mode **G** by the procedure from 3 to 5 which has been described to page 3-S49.
3. “**SHOCK**” is displayed (b) first and then the numerical code setting is displayed (c).  
The number “-9” through “+9” can be displayed. This has been factory-adjusted to “0”.
4. Setting;
  - For lighter shifting shock;  
Press the travel speed switch to reduce the number.
  - For higher shifting shock;  
Press the display mode switch to increase the number.
5. Move the tractor to confirm the shifting shock.
6. Turn off the key. Then setting will be put in memory.

#### ■ NOTE

- If the shift shock has been adjusted but no remarkable effect can be felt, keep the setting at “0”.

(a) Mode Selection Display

(c) Setting Number Display

(b) Information Display

W1030354

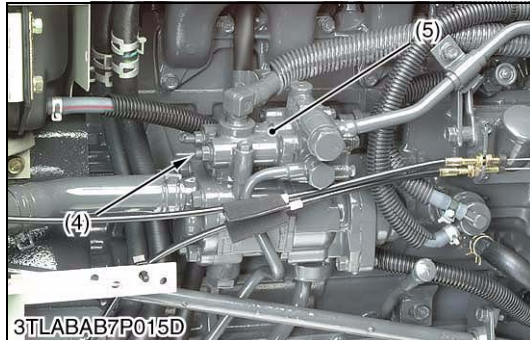
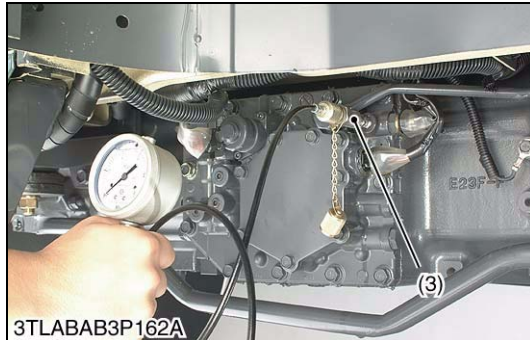
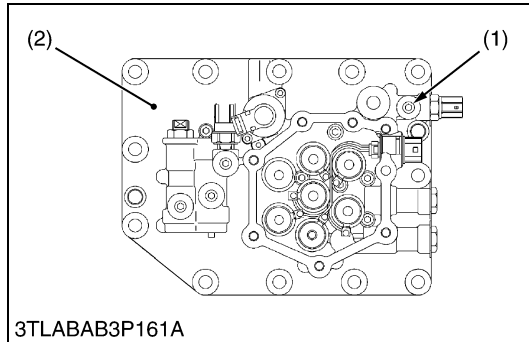
**(B) Hydraulic Checking****Checking GST System Pressure**

1. Start the engine and warm up the transmission fluid, and then stop the engine.
2. Remove the GST system pressure checking port (1) plug (PT 1/8) on the GST valve (2).
3. Install the GST valve adaptor (see page G-53) to checking port (1), and then install the threaded joint, cable and pressure gauge.
4. Start the engine and set the idling speed. Set the shift levers to "Neutral".
5. Measure the pressure.
6. If the measurement is not within factory specifications, adjust the pressure reducing valve adjustor (4) on the regulating valve assembly (5).

GST system pressure	Factory spec.	2.40 to 2.55 MPa 24.5 to 26.0 kgf/cm <sup>2</sup> 348 to 370 psi
---------------------	---------------	--

**Condition**

- Engine speed : Idling speed
- Oil temperature : 40 to 60 °C  
104 to 140 °F

**(Reference)**

- Turn to clockwise direction → Pressure is increased
- Turn to counterclockwise direction → Pressure is decreased

- |  |                                      |
|--|--------------------------------------|
| (1) GST System Pressure Checking Port (PT 1/8) | (3) GST Valve Adaptor                |
| (2) GST Valve                                  | (4) Pressure Reducing Valve Adjustor |
|  | (5) Regulating Valve Assembly        |

W1030916

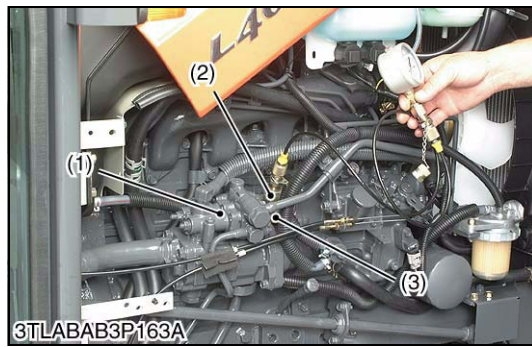

3TLABAB3P163A

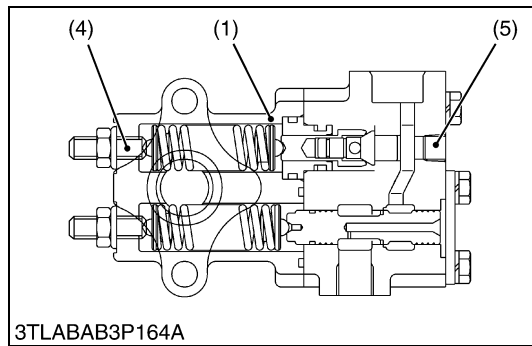

3TLABAB3P164A

### Checking Regulating Valve Setting Pressure

1. Start the engine and warm up the transmission fluid, and then stop the engine.
2. Remove the pressure checking port (5) plug (PT 1/8).
3. Install the adaptor "7" to checking port (5) and then install the adaptor "D", the threaded joint, cable and pressure gauge.
4. Start the engine and set the maximum engine speed. Set the shift levers to "Neutral".
5. Measure the pressure. (Do not turn the steering wheel.)
6. If the measurement is not within factory specifications, adjust the regulating valve adjuster (4) on the regulating valve assembly (1).

Regulating valve setting pressure	Factory spec.	2.74 to 2.94 MPa 28.0 to 30.0 kgf/cm <sup>2</sup> 398 to 427 psi
-----------------------------------	---------------	--

#### Condition

- Engine speed : Maximum
- Oil temperature : 40 to 60 °C  
104 to 140 °F

#### (Reference)

- Turn to clockwise direction → Pressure is increased
- Turn to counterclockwise direction → Pressure is decreased

(1) Regulating Valve Assembly

(4) Regulating Valve Adjustor

(2) Adaptor D

(5) Checking Port (PT 1/8)

(3) Adaptor 7

W1031426

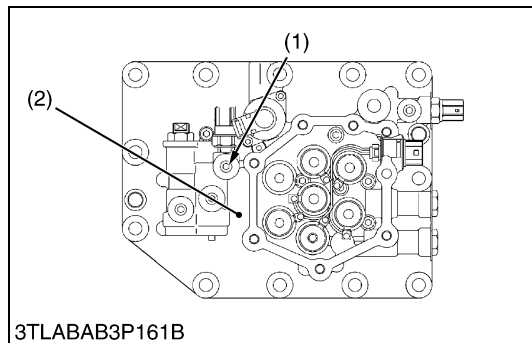

3TLABAB3P161B

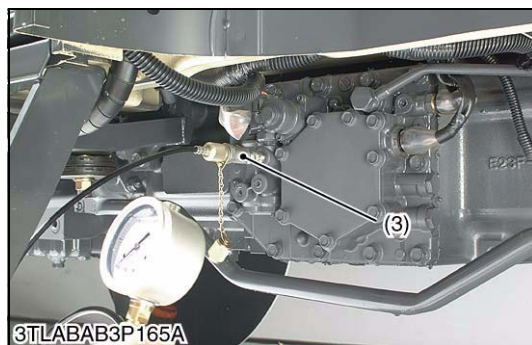

3TLABAB3P165A

### Checking Pilot Pressure

1. Start the engine and warm up the transmission fluid, and then stop the engine.
2. Remove the pilot pressure checking port plug (PT 1/8) on the GST valve (2).
3. Install the adaptor "D" or GST valve adaptor (3) to the checking port (1), and then install the threaded joint, cable and pressure gauge.
4. Start the engine and set the maximum speed.
5. Disengage the main clutch and shift the GST lever to "1st" position, shuttle shift lever to "Forward" or "Reverse" position.
6. Measure the pressure.
7. When the pilot pressure is not within factory specifications :  
Check the pilot orifice is clogged, movement of the shift forks, shift pistons and shift check valves.

#### ■ IMPORTANT

- Do not engage the main clutch while checking.

Pilot pressure	Factory spec.	2.30 to 2.50 MPa 23.5 to 25.5 kgf/cm <sup>2</sup> 334 to 363 psi
----------------	---------------	--

#### Condition

- Engine speed : Maximum
- Oil temperature : 40 to 60 °C  
104 to 140 °F
- Shifting : GST lever to be "1st"  
Shuttle shift lever to be "Forward" or "Reverse"

(1) Pilot Pressure Checking Port  
(PT 1/8)

(2) GST Valve

(3) Adaptor

W1031829



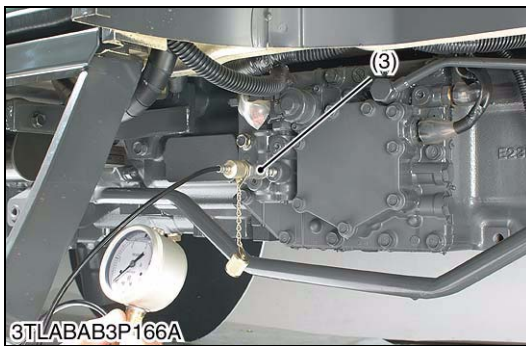
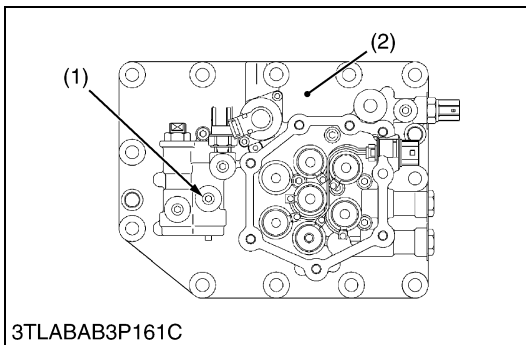

### Checking Clutch Pack Pressure

1. Start the engine and warm up the transmission fluid, and then stop the engine.
2. Remove the clutch pack pressure checking port plug (PT 1/8) on the GST valve (2).
3. Install the adaptor "D" or GST valve adaptor to the checking port (1), and then install the threaded joint, cable and pressure gauge.
4. Start the engine and set the idling speed.
5. Disengage the main clutch and shift the GST lever to "1st" position, shuttle shift lever to "Forward" position.
6. Measure the pressure.
7. When the clutch pack pressure is not within factory specifications:  
Check the clutch valve and clutch pack.
8. Check the pressure changes while shifting the shuttle shift lever "Reverse" to "Forward" and shifting the GST lever from "Neutral" to "12th" or "8th".
9. If the pressure does not change correctly, check the low-pass valve and proportional reducing valve.

#### ■ IMPORTANT

- Do not engage the main clutch while checking.

Clutch pack pressure	Factory spec.	2.30 to 2.50 MPa 23.5 to 25.5 kgf/cm <sup>2</sup> 334 to 363 psi
Pressure changing while shifting the shuttle shift lever and main shift lever		It drops on 0.29 MPa (3 kgf/cm <sup>2</sup> , 43 psi) once, and it rises to factory specification quickly.

#### Condition

- Engine speed : Maximum
- Oil temperature : 40 to 60 °C  
104 to 140 °F
- Shifting : GST lever "Neutral" to "1st" to "12th" or "8th"  
Shuttle shift lever "Neutral" to "Forward" or "Reverse"

(1) Clutch Pack Pressure Checking Port (PT 1/8)      (2) GST Valve  
(3) Adaptor

W1032163

### (C) Others

#### Operating Pressure of PTO Clutch Valve

1. See page 3-S17.

W1032841



## (2) Disassembling and Assembling

### (A) Clutch Housing

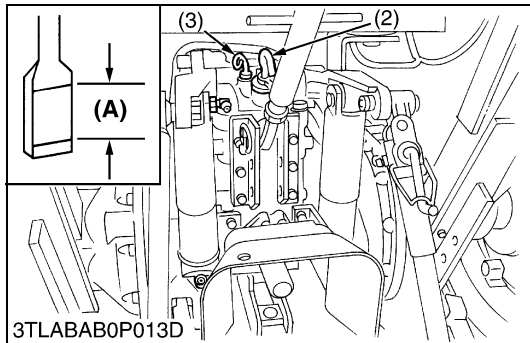
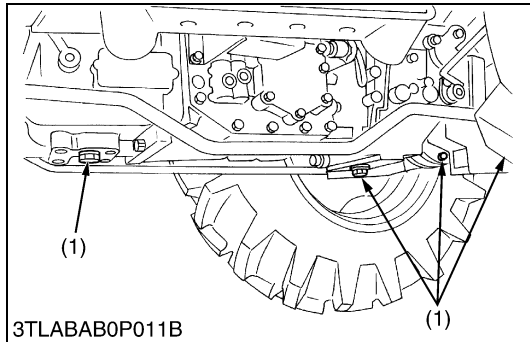

#### Draining the Transmission Fluid

1. Place oil pans underneath the transmission case.
2. Remove the drain plugs (1).
3. Drain the transmission fluid.
4. Reinstall the drain plugs (1).

#### (When refilling)

- Fill up from filling port after removing the filling plug (2) until reaching the upper notch on the dipstick (3).
- After running the engine for few minutes, stop it and check the oil level again, add the fluid to prescribed level if it is not correct level.

Transmission fluid capacity	L4630	43 L 11.4 U.S.gals 9.5 Imp.gals
	L5030	45 L 11.9 U.S.gals 9.9 Imp.gals

#### ■ IMPORTANT

- Use only KUBOTA SUPER UDT fluid. Use of other oils may damage the transmission or hydraulic system. Refer to “LUBRICANTS, FUEL AND COOLANT”. (See page G-7, 8.)
- Do not mix different brands of fluid together.

- (1) Drain Plugs  
(2) Filling Plug  
(3) Dipstick

(A) Oil level is acceptable within this range.

W1166268



#### Battery, Front Grill, Skirt and Bonnet

1. Open the bonnet and disconnect the battery negative cable.
2. Disconnect the head light connector and remove the front grill (4).
3. Remove the left and right side skirts (3).
4. Disconnect window washer hoses (2). (Cabin model only.)
5. Remove the bonnet (1).

#### ■ NOTE

- When disconnecting the battery cords, disconnect the negative cord first, when connecting, positive cord first.

- (1) Bonnet  
(2) Window Washer Hose  
(3) Skirt  
(4) Front Grill

W1033112

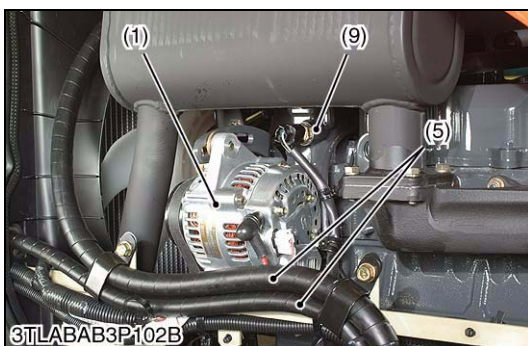
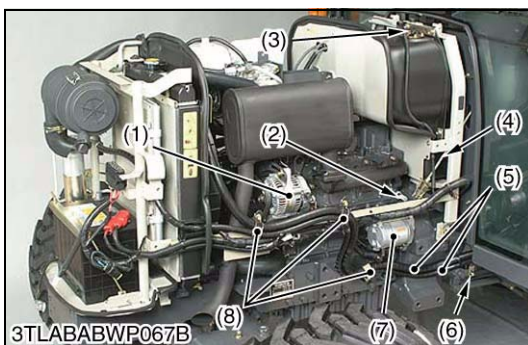
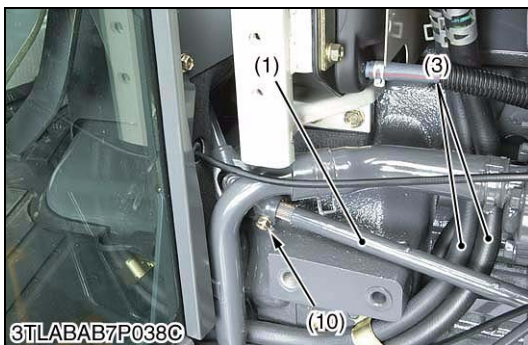
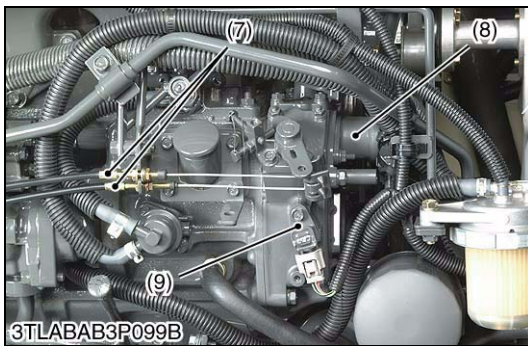
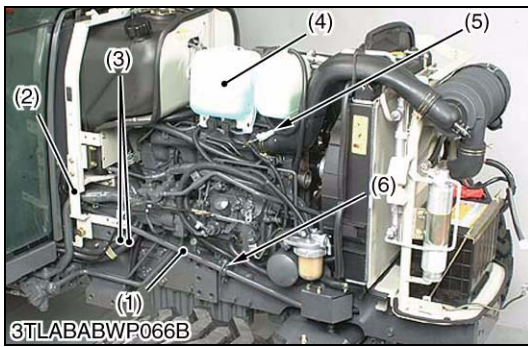

### **Steering Joint, Brake Pedal Rod and Electric Wiring**

1. Remove the tank frame support (2).
2. Remove the universal joint bolt (10) and steering joint support (6), and then remove the steering joint (1).
3. Disconnect the hand accelerator wire and foot accelerator wire (7).
4. Disconnect the wiring connectors for engine stop solenoid (8), engine tachometer sensor (9) and glow plug.
5. Disconnect the heater hoses (3), and then reconnect their hoses to make loop.

#### ■ NOTE

- Put a mark to the each heater hose before disconnecting.
6. Disconnect the wiring connector for window washer tank (4) and compressor **1P** connector (5).
  7. Disconnect the brake pedal rod.

#### **(When reassembling)**

- When accelerator wire is installed, adjust the wiring length as hit both the idling speed adjusting bolt and the maximum speed adjusting bolt by lever within the stroke of the accelerator lever.
- Set the steering joint (1) by the joint support (6) so that the steering wheel is turned lightly.
- Be sure to check and adjust the brake pedal free travel. (See page G-18.)

- |                         |                              |
|-------------------------|------------------------------|
| (1) Steering Joint      | (6) Steering Joint Support   |
| (2) Tank Frame Support  | (7) Accelerator Wire         |
| (3) Heater Hose         | (8) Engine Stop Solenoid     |
| (4) Window Washer Tank  | (9) Engine Tachometer Sensor |
| (5) <b>1P</b> Connector | (10) Universal Joint Bolt    |

W1033546

### **Clutch Rod, Brake Pedal Rod and Electric Wiring**

1. Disconnect the brake pedal rod (6) and clutch rod (4).
2. Disconnect the wiring connectors for alternator (1), coolant temperature sensor (9), oil pressure switch (2), fuel unit (3), starter motor (7) and battery.
3. Remove the clamps and ground earth of wiring harness and collect wiring harness to the step or cabin.
4. Remove the clamps (8) of A/C hoses (5). (A/C model only.)

#### **(When reassembling)**

- Be sure to check and adjust the clutch and brake pedal free travel. (See page G-18, 24.)

- |                         |                                |
|-------------------------|--------------------------------|
| (1) Alternator          | (6) Brake Pedal Rod            |
| (2) Oil Pressure Switch | (7) Starter Motor              |
| (3) Fuel Unit           | (8) Clamps                     |
| (4) Clutch Rod          | (9) Coolant Temperature Sensor |
| (5) A/C Hoses           |                                |

W1033897



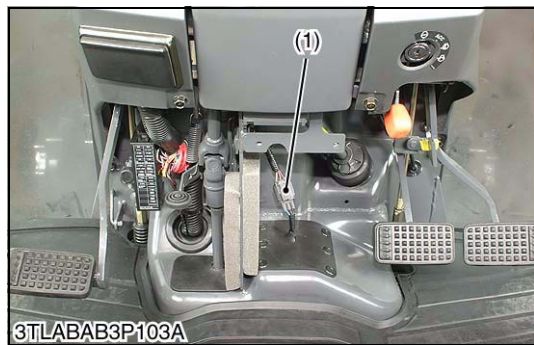
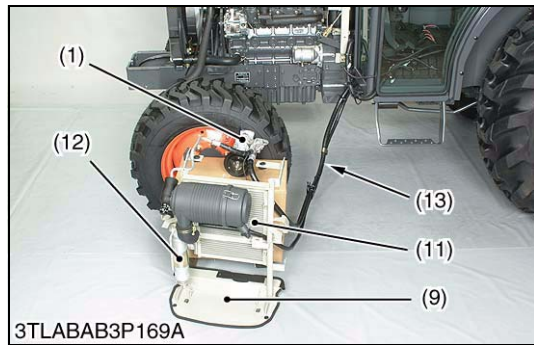
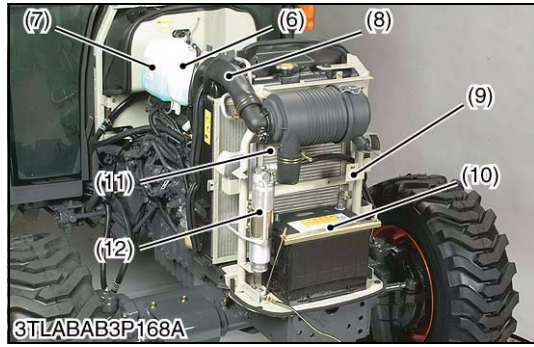
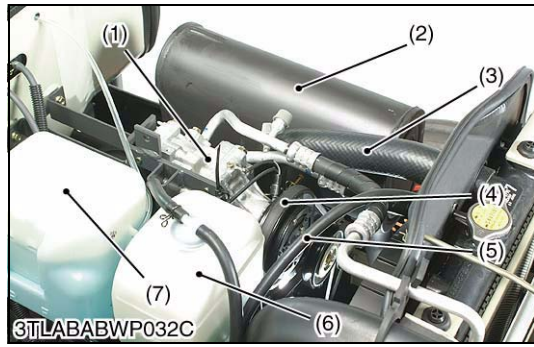

**Air Conditioner Parts (A/C Model)**

1. Remove the muffler (2).
2. Remove the air conditioner belt (4) and remove the compressor (1) mounting screw.
3. Remove the recovery tank (6) and window washer tank (7).
4. Disconnect the air cleaner hose (8).
5. Disconnect the recovery tank hose (5).
6. Disconnect the radiator upper hose (3).
7. Remove the battery (10).
8. Remove the battery stay mounting bolt.
9. Take out the compressor (1), condenser (11), receiver (12), hoses (13), battery stay (9) and etc. as a unit.

**(When reassembling)**

- After reassembling the compressor, be sure to adjust the air conditioner belt tension. (See page G-29.)

Tightening torque	Compressor mounting screw	24.5 to 29.4 N·m 2.5 to 3.0 kgf·m 18.1 to 21.7 ft·lbs
	Muffler mounting screw	31.4 to 37.2 N·m 3.2 to 3.8 kgf·m 23.1 to 27.5 ft·lbs

- |                          |                           |
|--------------------------|---------------------------|
| (1) Compressor           | (8) Air Cleaner Hose      |
| (2) Muffler              | (9) Battery Stay          |
| (3) Radiator Upper Hose  | (10) Battery              |
| (4) Air Conditioner Belt | (11) Condenser            |
| (5) Recovery Tank Hose   | (12) Receiver             |
| (6) Recovery Tank        | (13) Air Conditioner Hose |
| (7) Window Washer Tank   |                           |

W1034133

**Shuttle Switch Connector**

1. Remove the panel cover and steering post cover.
2. Disconnect the shuttle switch connector (1).

- (1) Shuttle Switch Connector

W1172874

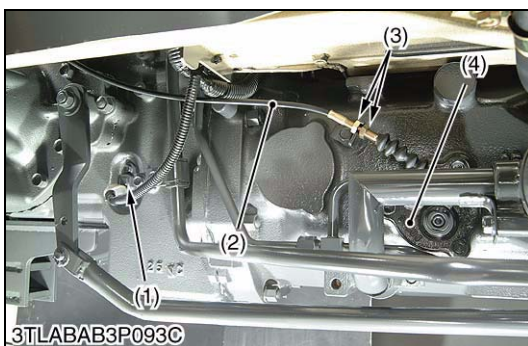
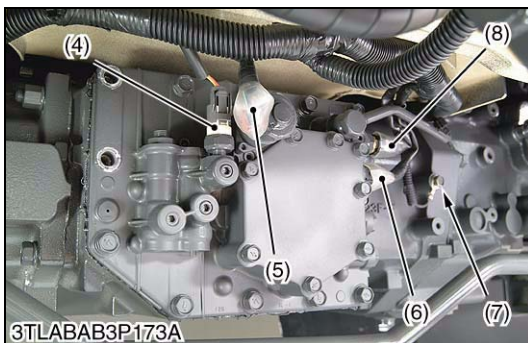
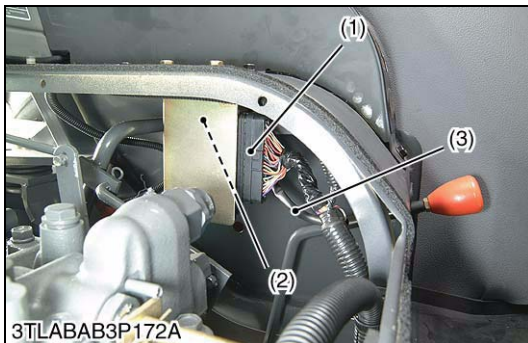
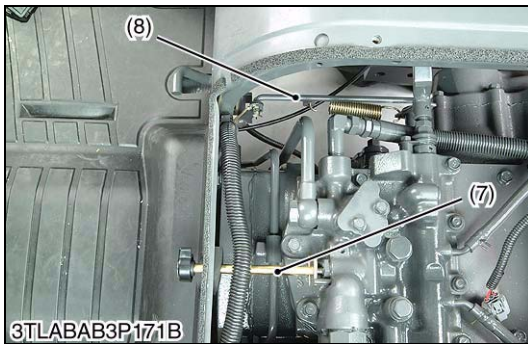
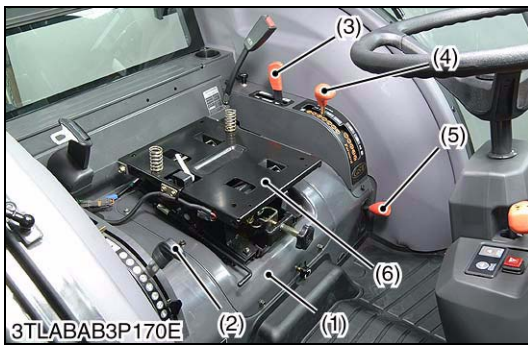

### Seat, Seat Bracket and Lever Grips

1. Remove the seat.
2. Remove the seat bracket (1) with seat suspension (6).
3. Remove the lever grips for position control lever (2), front wheel drive lever (5), GST lever (4) and creep shift lever (3).
4. Disconnect the differential lock rod (8).
5. Remove the lowering speed adjusting knob (7).

- |                            |                                   |
|----------------------------|-----------------------------------|
| (1) Seat Bracket           | (5) Front Wheel Drive Lever       |
| (2) Position Control Lever | (6) Seat Suspension               |
| (3) Creep Shift Lever      | (7) Lowering Speed Adjusting Knob |
| (4) GST Lever              | (8) Differential Lock Rod         |

W1046526

### Electric Connector for GST

1. Disconnect the ECU connector (1).
2. Disconnect the GST lever sensor connector (2).
3. Remove the GST valve cover.
4. Disconnect the pressure switch connector (4), proportional reducing valve connector (5), solenoid valve connector (6), oil temperature sensor connector (8) and ground cables (7).

- |  |   |
|--|---|
| (1) ECU Connector                      | (5) Proportional Reducing Valve Connector |
| (2) GST Lever Sensor Connector         | (6) Solenoid Valve Connector              |
| (3) Wiring Harness of GST Lever Sensor | (7) Ground Cable                          |
| (4) Pressure Switch Connector          | (8) Oil Temperature Sensor Connector      |

W1046759

### PTO Shift Wire and Electric Connector

1. Disconnect the PTO shift wire (2) at the PTO clutch valve (4).
2. Disconnect the traveling speed sensor connector (1).

#### **(When reassembling)**

- When connecting the PTO shift wire (2) to the clutch valve (4), be sure to adjust the length of wire as follows.
  1. Set the PTO shift lever to **OFF (Neutral)** position.
  2. Loosen the lock nut (3) of wire, and connect wire to the clutch valve lever, and then place the wire to the hook.
  3. Tighten the lock nut (3) clockwise (pull the wire), and lock the nut just before the lever moves.

- |                                      |                      |
|--------------------------------------|----------------------|
| (1) Traveling Speed Sensor Connector | (3) Lock Nut         |
| (2) PTO Shift Wire                   | (4) PTO Clutch Valve |

W1046922





### Cabin Assembly

1. Remove the outer roof of cabin.
2. Support the cabin with nylon straps (1) and hoists.
3. Loosen and remove the cabin mounting bolts (2) and nuts (9).
4. Dismounting the cabin from tractor body.

#### NOTE

- Lift the cabin while making sure it does not catch on anything.

#### (When reassembling)

- Be sure to install the washers and mount rubbers, etc. in their original positions.
- Before mounting the cabin, be sure to set both the shuttle lever rod and the shuttle arm to the neutral position, and then connect the shuttle lever rod securely.

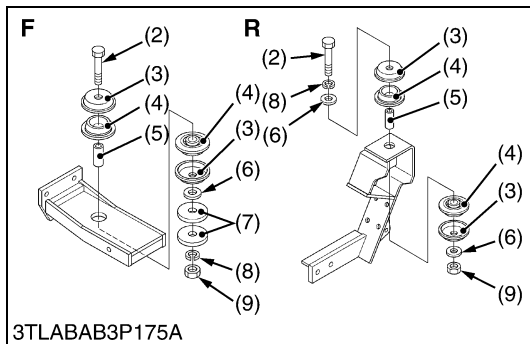

Tightening torque	Cabin mounting bolt and nut	124 to 147 N·m 12.6 to 15.0 kgf·m 91.1 to 108 ft·lbs
-------------------	-----------------------------	--

- (1) Nylon Straps
  - (2) Bolt
  - (3) Plate
  - (4) Mount Rubber
  - (5) Collar
  - (6) Plain Washer (M14)
  - (7) Washer
  - (8) Spring Washer
  - (9) Nut
- F : Front Side**  
**R : Rear Side**

W1047429

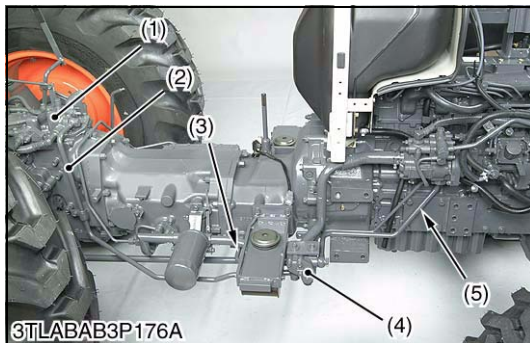

### Hydraulic Pipes

1. Remove the main delivery pipe 1 (5).
2. Disconnect the main delivery pipe 2 (2) at the rear hydraulic block (1) and return pipe (3) at the mid case, and then remove the front hydraulic block (4) with pipes and bracket as a unit.
3. Remove the suction pipe (8) with oil filter (7).
4. Remove the PTO delivery pipe (9) and GST pipe (6) as a unit.

#### (When reassembling)

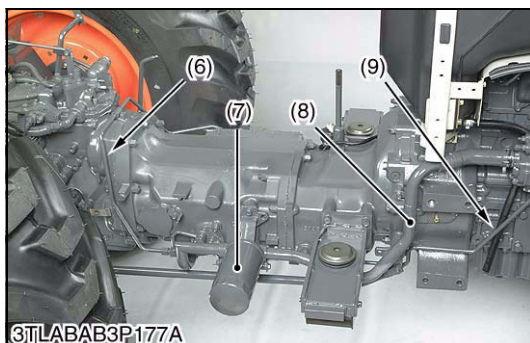

Tightening torque	Joint bolt for main delivery pipe 1 to front hydraulic block	49 to 69 N·m 5.0 to 7.0 kgf·m 36.1 to 50.6 ft·lbs
	Joint bolt for main delivery pipe 2 to front hydraulic block	49 to 69 N·m 5.0 to 7.0 kgf·m 36.1 to 50.6 ft·lbs
	Cap nut for return pipe to mid case	49 to 69 N·m 5.0 to 7.0 kgf·m 36.1 to 50.6 ft·lbs
	Joint bolt for PTO / GST delivery pipe	34 to 39 N·m 3.5 to 4.0 kgf·m 25.3 to 28.9 ft·lbs

- (1) Rear Hydraulic Block
- (2) Main Delivery Pipe 2
- (3) Return Pipe
- (4) Front Hydraulic Block
- (5) Main Delivery Pipe 1
- (6) GST Pipe
- (7) Hydraulic Oil Filter
- (8) Suction Pipe
- (9) PTO Delivery Pipe

W1047928

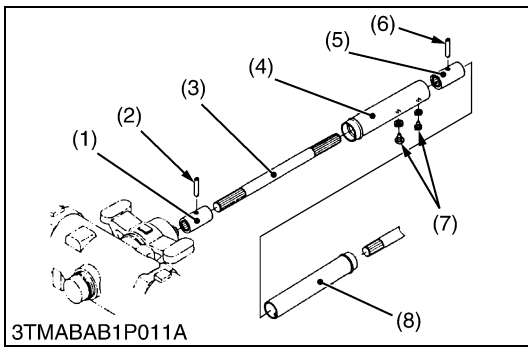

3TMABAB1P011A

**Propeller Shaft**

1. Slide the propeller shaft cover (4) and (8) after removing the screws (7).
2. Tap out the spring pins (2), (6) and slide the couplings (1), (5) and then remove the propeller shaft with covers (4), (8).

**(When reassembling)**

- Apply grease to the splines of propeller shaft 1 (3).

- |                           |                           |
|---------------------------|---------------------------|
| (1) Coupling              | (5) Coupling              |
| (2) Spring Pin            | (6) Spring Pin            |
| (3) Propeller Shaft 1     | (7) Screws                |
| (4) Propeller Shaft Cover | (8) Propeller Shaft Cover |

W1176284

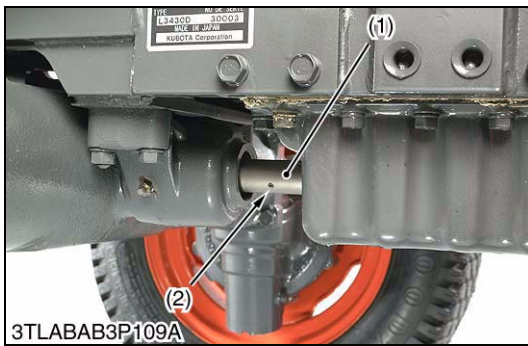

3TLABAB3P109A

**Separating Engine and Clutch Housing**

1. Place the disassembling stand under the engine and clutch housing case.
2. Remove the fuel tank support mounting screws.
3. Remove the engine and clutch housing mounting screws and nuts.
4. Separate the engine and clutch housing while lifting up the tank frame.

**(When reassembling)**

- Apply grease to the spline of clutch shaft.
- Apply liquid gasket (Three Bond 1211 or equivalent) to joint face of the flywheel housing and clutch housing.



3TLABAB3P178A

Tightening torque	Engine and clutch housing mounting screw and nut	77.5 to 90.2 N-m 7.9 to 9.2 kgf-m 57.1 to 66.5 ft-lbs
	Engine and clutch housing mounting stud bolt	39.2 to 49.0 N-m 4.0 to 5.0 kgf-m 28.9 to 36.2 ft-lbs

W1048295

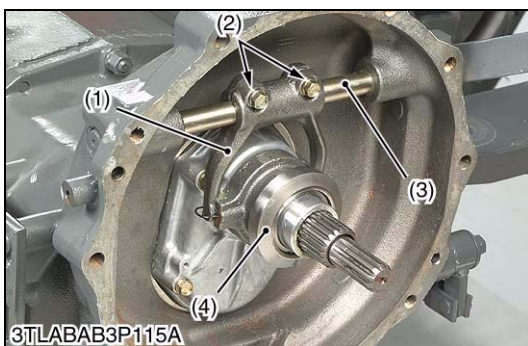

3TLABAB3P115A

**Clutch Lever, Release Fork and Release Bearing**

1. Remove the release fork mounting screws (2).
2. Draw out the clutch lever (3) to remove the release fork (1).
3. Remove the release bearing and release hub (4) together.

**(When reassembling)**

- Apply grease to the sliding surface of the clutch release hub.
- Apply grease to the clutch lever.

Tightening torque	Release fork mounting screw	23.5 to 27.5 N-m 2.4 to 2.8 kgf-m 17.4 to 20.3 ft-lbs
-------------------	-----------------------------	---

- |                                 |                  |
|---------------------------------|------------------|
| (1) Release Fork                | (3) Clutch Lever |
| (2) Release Fork Mounting Screw | (4) Release Hub  |

W11766950



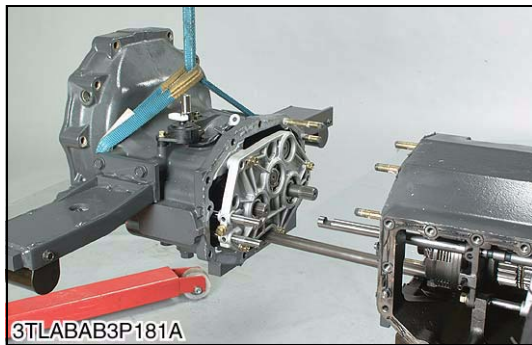
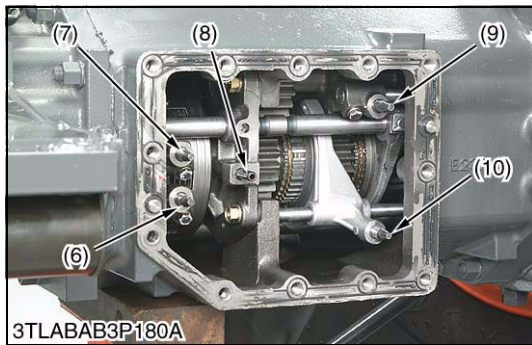
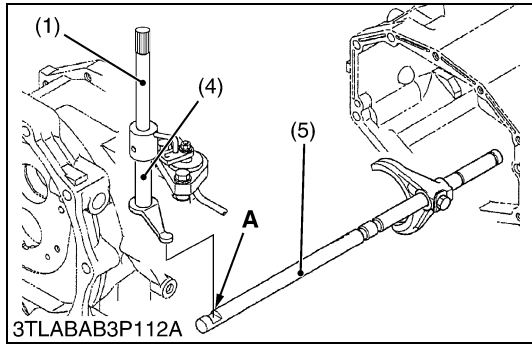
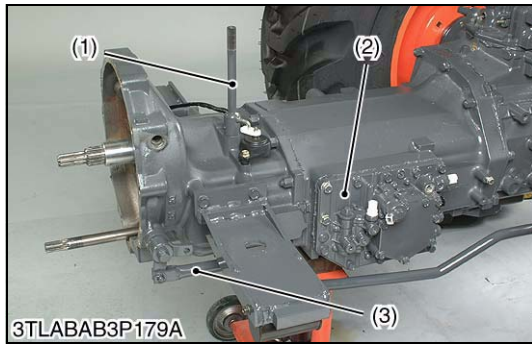

**Shuttle Shift Arm and GST Valve Assembly**

1. Disconnect the brake rod (3).
2. Remove the shuttle shift arm stopper screw, and then pull the shuttle shift shaft (1) with arm up.
3. Remove the GST valve (2) with using two jack bolts.
4. Remove the shift pins (6), (7).

**NOTE**

- Do not fall down the shuttle check pin (9) while disassembling.

**(When reassembling)**

- When reassembling the shuttle shift arm (4) to the shuttle fork rod (5), be sure to install it to the groove A.
- Place the 1-2 shift pin (6) and the 3-4 shift pin (7) at **neutral** position, main range shift pin (9) at **L** position (forward) and sub-range shift pin (10) at **Hi** position (rearward), and then assemble the GST valve.
- Be sure to match the each shift pin and shift piston.
- Apply liquid gasket (Three Bond 1208D or equivalent) to joint face of the GST valve assembly.
- Install the GST valve (2) by hand, and then tighten the screws. Do not use the hammer.
- Replace the pipe (8) with new one, if damaged.

Tightening torque	Shift pin mounting screws	12.7 to 14.7 N·m 1.3 to 1.5 kgf·m 9.4 to 10.8 ft·lbs
	GST valve mounting screws	42.2 to 48.1 N·m 4.3 to 4.9 kgf·m 31.1 to 35.4 ft·lbs

- |                       |                            |
|-----------------------|----------------------------|
| (1) Stopper Screw     | (7) 3-4 Shift Pin          |
| (2) GST Valve         | (8) Pipe                   |
| (3) Brake Rod         | (9) Main Range Shift Pin   |
| (4) Shuttle Shift Arm | (10) Sub-range Shift Pin   |
| (5) Shuttle Fork Rod  |                            |
| (6) 1-2 Shift Pin     | <b>A : Fork Rod Groove</b> |

W1048476

**Separating Clutch Housing and Mid Case**

1. Remove the clutch housing and mid case mounting screws and nuts.
2. Separate the clutch housing and mid case.

**(When reassembling)**

- Apply liquid gasket (Three Bond 1208D or equivalent) to joint face of the clutch housing and mid case.

Tightening torque	Clutch housing and mid case mounting nut	102.9 to 117.6 N·m 10.5 to 12.0 kgf·m 75.9 to 86.8 ft·lbs
	Clutch housing and mid case mounting screw	77.5 to 90.2 N·m 7.9 to 9.2 kgf·m 57.1 to 66.5 ft·lbs
	Clutch housing and mid case mounting stud bolt	38.2 to 45.1 N·m 3.9 to 4.6 kgf·m 28.2 to 33.3 ft·lbs

W10489710

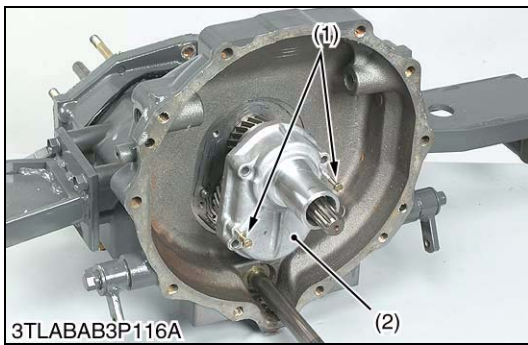

### Shaft Case

1. Remove the shaft case mounting screws.
2. Screw down the two M6 screws (1) into the shaft case (2) and pull it out.
3. Take out the shaft case (2).

#### (When reassembling)

- Apply liquid gasket (Three Bond 1208D or equivalent) to joint face of the shaft case and clutch housing case.

#### (When replacing oil seal in shaft case)

- Install the oil seal (3) as shown in the figure, noting its direction.
- Apply grease to the oil seal (3).

- |                |              |
|----------------|--------------|
| (1) M6 Screw   | (3) Oil Seal |
| (2) Shaft Case |              |

W11776010

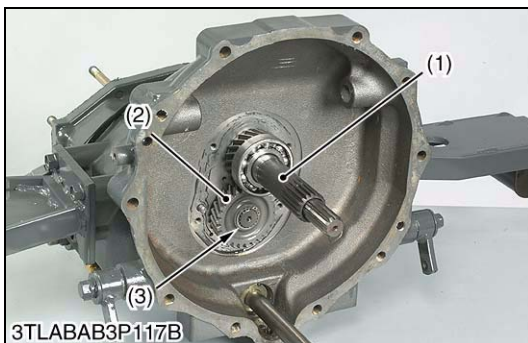
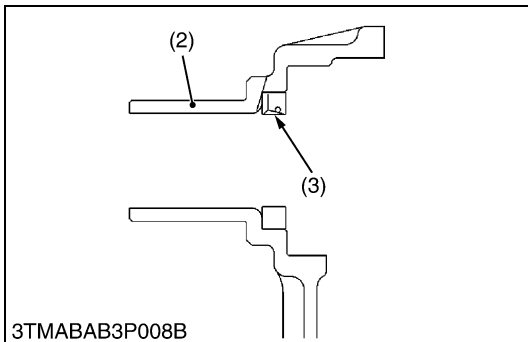

### 23T (24T) Gear Shaft and 27T (26T) Gear

1. Remove the 23T (24T) gear shaft (1).
2. Remove the external snap ring (3) and 27T (26T) gear (2).

#### (When reassembling)

- Install the oil seal (4) on the 18T gear shaft (6), noting the direction of the oil seal (4) as shown in the figure.
- Direct the boss side of the gear (2) to the bearing side.
- Apply small amount of the grease to the oil seal (4), (5).

- |                            |                        |
|----------------------------|------------------------|
| (1) 23T Gear Shaft (L4630) | (3) External Snap Ring |
| 24T Gear Shaft (L5030)     | (4) Oil Seal           |
| (2) 27T Gear (L4630)       | (5) Oil Seal           |
| 26T Gear (L5030)           | (6) 18T Gear Shaft     |

W1049580

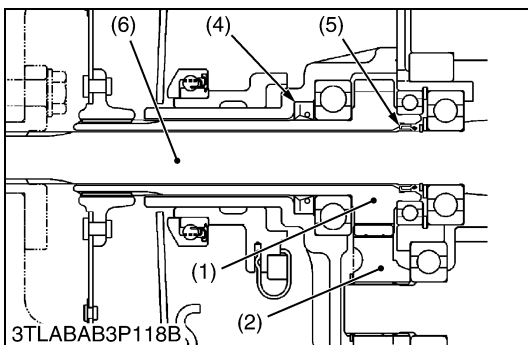

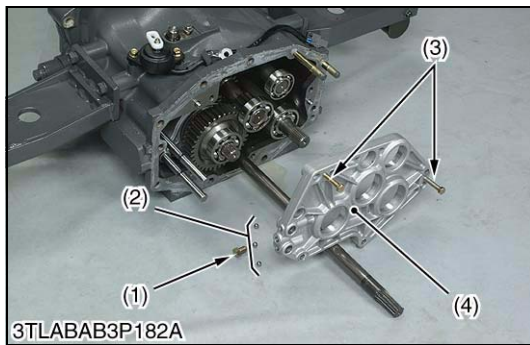

### Clutch Housing Bearing Holder

1. Remove the three interlock balls (2) after removing the stopper screw (1).
2. Pull out the clutch housing bearing holder (4) with using two jack bolts (3).

#### (When reassembling)

- Tap in the clutch housing bearing holder (4) with plastic hammer until contact to clutch housing case, and then tighten the screws to specified torque.
- Install the three interlock balls (2) with a small amount of grease to the clutch housing bearing holder (4) after setting the shift forks and shift rods to the neutral position.

Tightening torque	Clutch housing bearing holder mounting screw	48.1 to 55.9 N·m 4.9 to 5.7 kgf·m 35.4 to 41.2 ft-lbs
	Stopper screw	34.3 to 44.1 N·m 3.5 to 4.5 kgf·m 25.3 to 32.5 ft-lbs

- (1) Stopper Screw (2) Interlock Ball (3) Jack Bolt (4) Clutch Housing Bearing Holder

W1049879

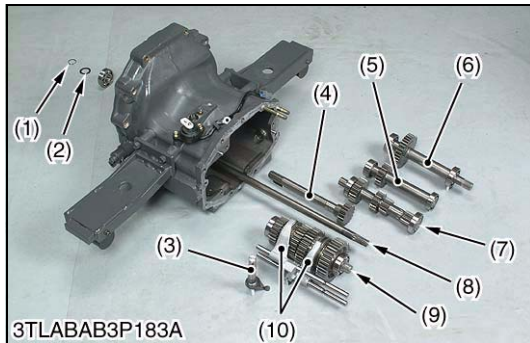

### Shaft Assemblies

1. Remove the external snap ring (1) and thrust collar (2).
2. Draw out the shaft assemblies (4), (5), (6), (7), (9) and shift forks (10) and rods.
3. Pull out the front axle drive shaft (8) to the rear side.

#### (When reassembling)

- Install the front axle drive shaft (8) from front side after assembling the clutch housing case and mid case. Then install the bearing (13), sleeve (14), collar (15), oil seal (12), internal snap ring (11), O-ring (16) and spacer (17) in order.

- (1) External Snap Ring (2) Collar (3) Shuttle Shift Arm (4) 18T Gear Shaft Assembly (5) Idle Shaft Assembly (6) PTO Counter Shaft Assembly (7) Main Gear Shaft Assembly (8) Front Axle Drive Shaft (9) Counter Shaft Assembly (10) Shift Fork (11) Internal Snap Ring (12) Oil Seal (13) Bearing (14) Sleeve (15) Collar (16) O-ring (17) Spacer

**F : Front Side**

W1050076

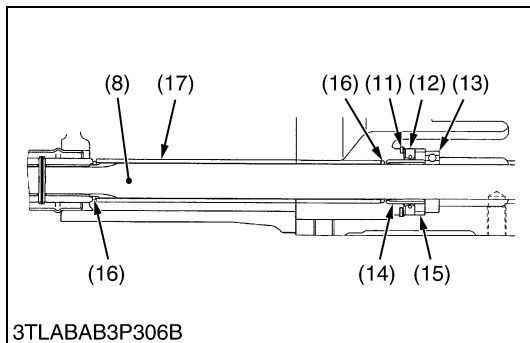

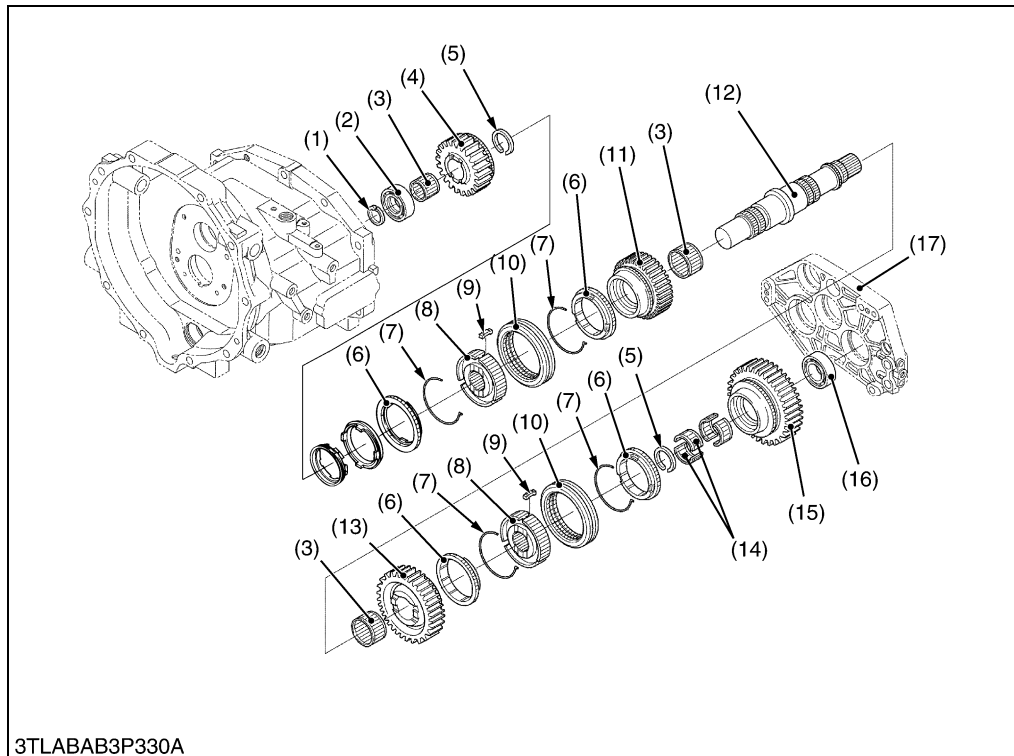
**Counter Shaft**

- (1) Internal Snap Ring
- (2) Bearing
- (3) Needle Bearing
- (4) 24T Gear (4th)
- (5) External Snap Ring
- (6) Synchronizer Ring
- (7) Synchronizer Spring
- (8) Hub
- (9) Synchronizer Key
- (10) Shifter
- (11) 29T Gear (3rd)
- (12) Counter Shaft
- (13) 34T Gear (2nd)
- (14) Needle Bearing
- (15) 37T Gear (1st)
- (16) Bearing
- (17) Bearing Holder
- (18) Inner Synchronizer Ring
- (19) Center Ring
- (20) Outer Synchronizer Ring

W1050216

3TLABAB3P330A

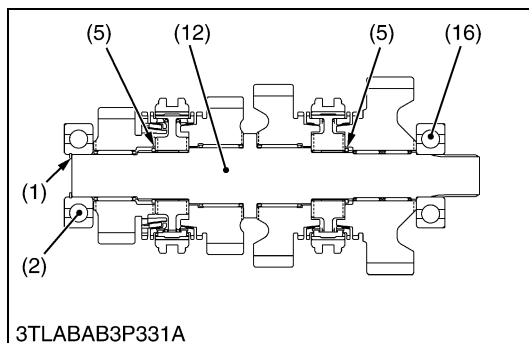

1. Remove the internal snap ring (1) and remove both side of the bearings (2), (16).
2. Remove the gears on the counter shaft (12) and external snap rings (5).

**(When reassembling)**

- Reinstall the synchronizer keys (9) in the key grooves of the synchronizer rings (6) or (20) firmly.
- Be sure to install the synchronizer rings (18), (19), (20) with referring to page 3-S31.

W1050447

3TLABAB3P331A



**(B) Mid Case**

■ **NOTE**

- For the disassembling procedure from “Draining the Transmission Fluid” to “Propeller Shaft”, refer to page 3-S55 to 3-S60.

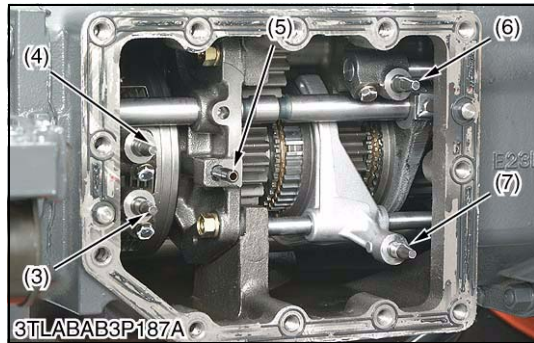
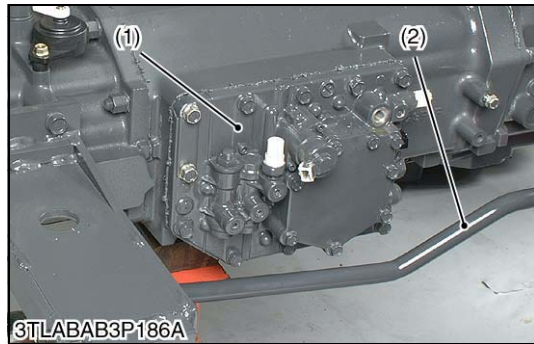

**GST Valve Assembly**

1. Disconnect the brake rods (2).
2. Remove the GST valve (1) with using two jack bolts.
3. Remove the shift pin (3), (4) and (6).

■ **NOTE**

- **Do not fall down the shuttle check pin while disassembling.**
- (When reassembling)**
  - Place the 1-2 (3) and 3-4 shift pins (4) at **neutral** position, sub-range shift pin (7) at **Hi** position (rearward) and main range shift pin (6) at **L** position (forward), and then assemble the GST valve.
  - Be sure to match the each shift pin and shift piston.
  - Install the GST valve (1) by hand, and then tighten the screws. Do not use the hummer.
  - Apply liquid gasket (Three Bond 1208D or equivalent) to joint face of the GST valve assembly.
  - Replace the pipe (5) with new one, if damaged.

Tightening torque	GST valve mounting screws	42.2 to 48.1 N·m 4.3 to 4.9 kgf·m 31.1 to 35.4 ft-lbs
	Shift pin mounting screw	12.7 to 14.7 N·m 1.3 to 1.5 kgf·m 9.4 to 10.8 ft-lbs

- (1) GST Valve
- (2) Brake Rod
- (3) 1-2 Shift Pin
- (4) 3-4 Shift Pin
- (5) Pipe
- (6) Main Range Shift Pin
- (7) Sub-range Shift Pin

W1050592



**Separating Mid Case and Transmission Case**

1. Separate the mid case and transmission case after removing their mounting screws.

**(When reassembling)**

- Confirm to insert the PTO shaft to PTO clutch firmly, turning the PTO shaft.
- Apply liquid gasket (Three Bond 1208D or equivalent) to joint face of the mid case and transmission case.

Tightening torque	Mid case and transmission case mounting screw	77.5 to 90.2 N·m 7.9 to 9.2 kgf·m 57.1 to 66.5 ft-lbs
	Mid case and transmission case mounting nut	102.9 to 117.6 N·m 10.5 to 12.0 kgf·m 75.9 to 86.8 ft-lbs
	Mid case and transmission case mounting stud bolt	39.2 to 49.0 N·m 4.0 to 5.0 kgf·m 28.9 to 36.2 ft-lbs

W1050879

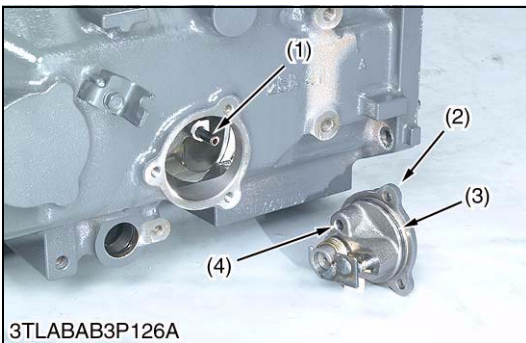
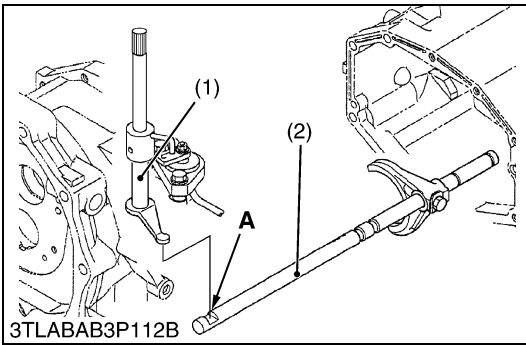

**Separating Mid Case**

1. Lift up the shuttle shift arm (1).
2. Separate the mid case from the clutch housing after removing their mounting screws.

**(When reassembling)**

- Apply liquid gasket (Three Bond 1208D or equivalent) to joint face of clutch housing and mid case.
- When reassembling the shuttle shift arm (1) to the shuttle fork rod (2), be sure to install it to the groove (A).

Tightening torque	Clutch housing and mid case mounting screw	77.5 to 90.2 N-m 7.9 to 9.2 kgf-m 57.1 to 66.5 ft-lbs
	Clutch housing and mid case mounting nut	102.9 to 117.6 N-m 10.5 to 12.0 kgf-m 75.9 to 86.8 ft-lbs
	Clutch housing and mid case mounting stud bolt	38.2 to 45.1 N-m 3.9 to 4.6 kgf-m 28.2 to 33.3 ft-lbs

- (1) Shuttle Shift Arm  
(2) Shuttle Fork Rod

**A : Fork Rod Groove**

W1051037

**PTO Clutch Valve**

1. Remove the PTO clutch valve (2) as a unit.
2. Pull out the pipe (1).

**(When reassembling)**

- Apply small amount of grease for the O-ring (3).
- Install the pipe (1) to the hole (4) of the PTO clutch valve (2) firmly.
- Replace the pipe (1) with new one.

Tightening torque	PTO clutch valve mounting screw	23.5 to 27.5 N-m 2.4 to 2.8 kgf-m 17.4 to 20.3 ft-lbs
-------------------	---------------------------------	---

- (1) Pipe  
(2) PTO Clutch Valve  
(3) O-ring  
(4) Hole

W1180630



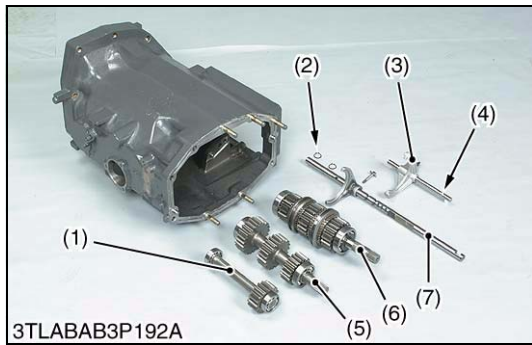
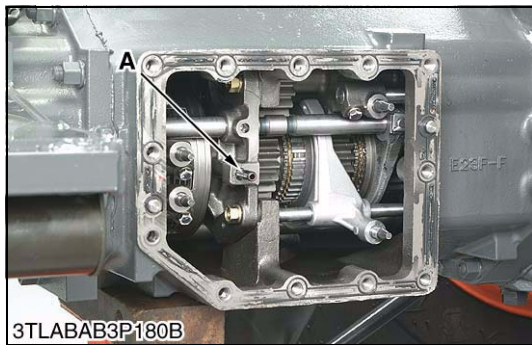
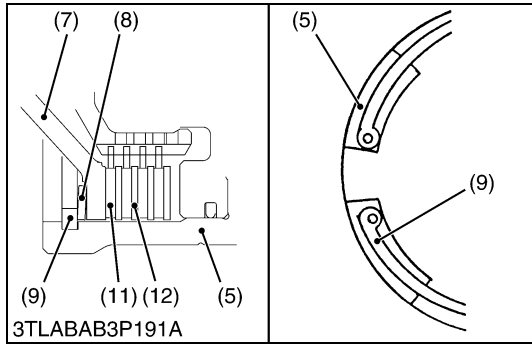
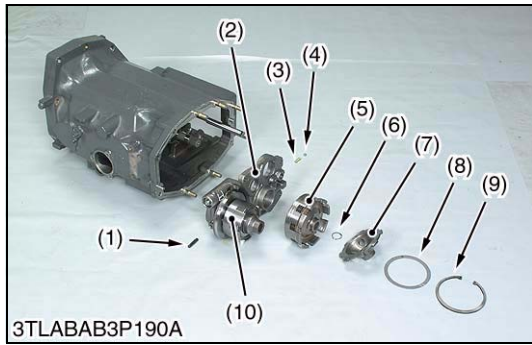

**Mid Case Bearing Holder**

1. Remove the internal snap ring (9) and remove the disc spring (8) and clutch input hub (7).
2. Remove the external snap ring (6) and remove the GST clutch case (5).
3. Remove the mid case bearing holder mounting screws, and then take out the bearing holder (2) with PTO clutch (10) by using two jack bolts.

**NOTE**

- Take care not to fly out the ball (4) and spring (3) when pull out the bearing holder (2).

**(When reassembling)**

- Tap in bearing holder (2) with plastic hammer until contact to case, and then tighten the screws to specified torque.
- Assemble the disc spring (8) as shown in the figure.
- Install the internal snap ring (9) to the clutch case (5) as shown in the figure.
- Confirm the moving of the piston smoothly when pressure air at 0.29 to 0.39 MPa (3 to 4 kgf/cm<sup>2</sup>, 42 to 57 psi) is sent to clutch pack. (Air must be sent from hole A.)

Tightening torque	Mid case bearing holder mounting screw	48.1 to 55.9 N·m 4.9 to 5.7 kgf·m 35.4 to 41.2 ft·lbs
-------------------	--	---

- |                             |                        |
|-----------------------------|------------------------|
| (1) PTO Clutch Pipe         | (8) Disc Spring        |
| (2) Mid Case Bearing Holder | (9) Internal Snap Ring |
| (3) Spring                  | (10) PTO Clutch        |
| (4) Ball                    | (11) Clutch Disc       |
| (5) Clutch Case             | (12) Steel Plate       |
| (6) External Snap Ring      |                        |
| (7) Clutch Input Hub        |                        |

**A : Oil Inlet Port for GST Clutch**

W1180845

**Shaft Assemblies**

1. Pull out the sub-range shift rod (4) and remove the shift fork (3).
2. Remove the external snap ring (2) which is located at rear side of the mid case.
3. Draw out the shaft assemblies (1), (5), (6) and shuttle fork rod (7).

- |                              |                        |
|------------------------------|------------------------|
| (1) Reverse Gear Shaft       | (5) Shuttle Gear Shaft |
| (2) External Snap Ring       | (6) Shuttle Shaft      |
| (3) Shift Fork               | (7) Shuttle Fork Rod   |
| (4) Sub-range Shift Fork Rod |                        |

W1183161

**Disassembling PTO Clutch**

1. See page 3-S32, S33.

W1289718

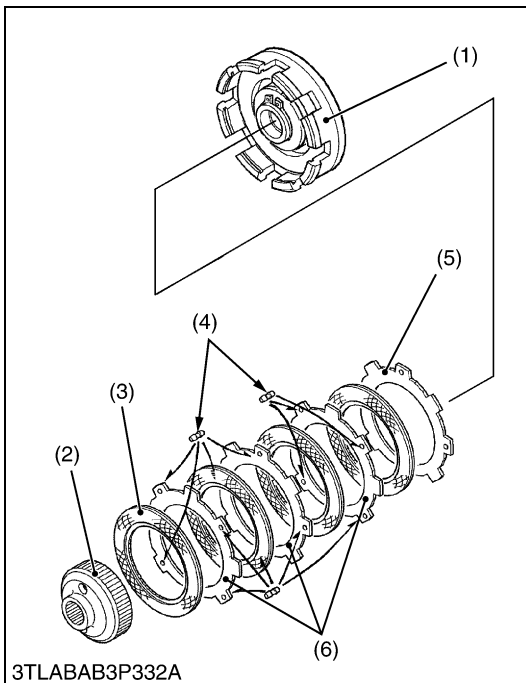

### **GST Clutch Discs**

1. Take out the clutch hub (2), clutch disc (3) and steel plate (5), (6) from clutch case (1).

#### **(When reassembling)**

- Assemble the three steel plates (6) with plug rubbers (4) to the front side, one steel plate (5) without plug rubber to the piston side. (Steel plate (5), (6) are used same part.)
- Do not pile up the plug rubber (4) portion on steel plates (6) while reassembling as shown in the figure.

- |                 |                                     |
|-----------------|-------------------------------------|
| (1) Clutch Case | (4) Plug Rubber                     |
| (2) Clutch Hub  | (5) Steel Plate without Plug Rubber |
| (3) Clutch Disc |                                     |

W1051729

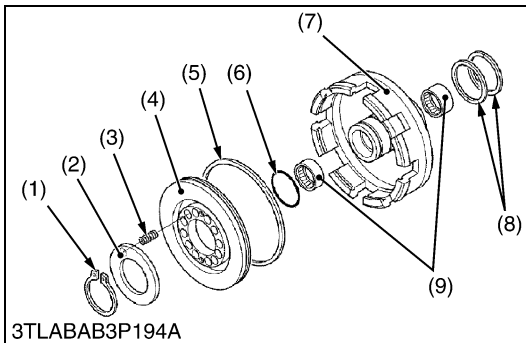

### **Clutch Case and GST Clutch Piston**

1. Remove the external snap ring (1) while pushing the spring retainer (2) by hand press.
2. Take out the spring retainer (2), springs (3) and piston (4).

#### **(When reassembling)**

- Apply small amount of the grease to the seal rings (8) when assemble the clutch case (7).
- Apply enough transmission fluid to the O-ring (6) and D-ring (5).

- |                        |                    |
|------------------------|--------------------|
| (1) External Snap Ring | (6) O-ring         |
| (2) Spring Retainer    | (7) Clutch Case    |
| (3) Spring             | (8) Seal Ring      |
| (4) Piston             | (9) Needle Bearing |
| (5) D-ring             |                    |

W1052192

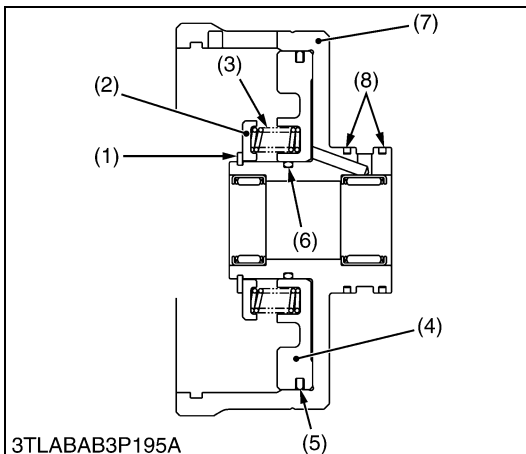

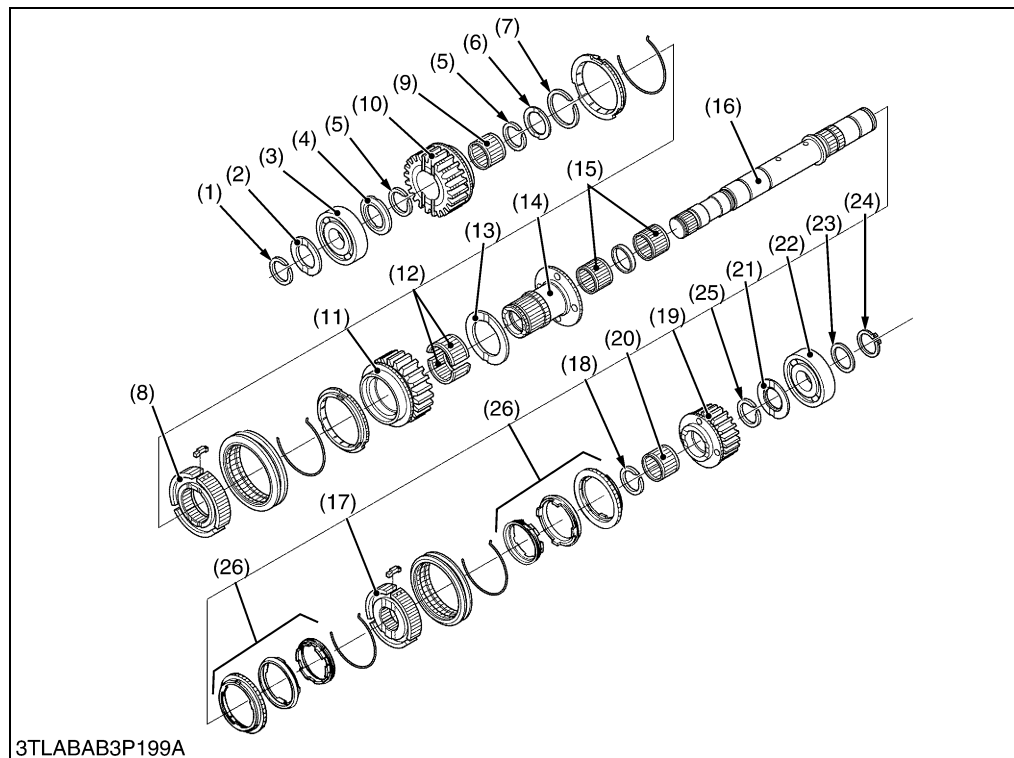
**Shuttle Shift Gears**

- (1) External Snap Ring
- (2) Thrust Collar
- (3) Bearing
- (4) Thrust Collar
- (5) External Snap Ring
- (6) Thrust Collar
- (7) External Snap Ring
- (8) Hub
- (9) Needle Bearing
- (10) 21T Gear
- (11) 24T Gear
- (12) Needle Bearing
- (13) Thrust Collar
- (14) Shuttle Forward Shaft
- (15) Needle Bearing
- (16) Shuttle Shaft
- (17) Hub
- (18) External Snap Ring
- (19) 18T Gear
- (20) Needle Bearing
- (21) Thrust Collar
- (22) Bearing
- (23) Collar
- (24) External Snap Ring
- (25) External Snap Ring
- (26) Synchronizer Ring

3TLABAB3P199A

W1186507

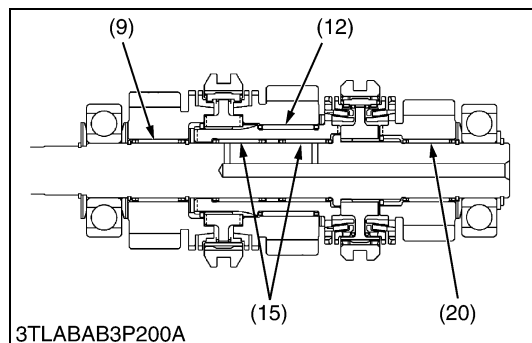

3TLABAB3P200A

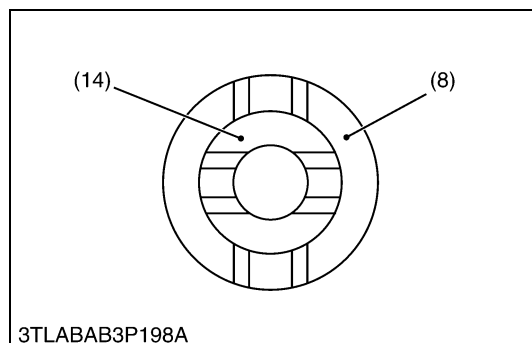

3TLABAB3P198A

1. Remove the external snap ring (1) and thrust collar (2).
2. Remove the bearing (3) and remove the thrust collar (4), 21T gear (10) and synchronizer ring.
3. Remove the external snap ring (7) and remove the hub (8) with shifter, synchronizer ring and 24T gear (11).
4. Remove the external snap rings (5) and remove the needle bearings, thrust collars (6), (13) and shuttle forward shaft (14).
5. Remove the external snap ring (24) and collar (23) and remove the bearing (22), thrust collar (21), 18T gear (19) and synchronizer rings.
6. Remove the external snap ring (25) and remove the needle bearing (20).
7. Remove the external snap ring (18) and remove the hub (17) with shifter and synchronizer rings.

**(When reassembling)**

- Direct the groove side of the thrust collars (4), (21) to the gear side.
- Reinstall the synchronizer keys in the key grooves of the synchronizer rings.
- Install the synchronizer rings (26) securely, referring to page 3-S44.
- Direct the groove side of the hub (8) and shuttle forward shaft (14) as shown in figure.

W1186665

### (C) Transmission Case

■ **NOTE**

- For the disassembling procedure from “Draining the Transmission Fluid” to “Cabin Assembly”, refer to page 3-S55 to 3-S60.



#### Rear Wheel

1. Place disassembling stand under the transmission case, and support it with a jack.
2. Remove the rear wheels.
3. After removing the rear wheels, support it at both sides of rear axle by stands.

#### (When reassembling)

Tightening torque	Rear wheel mounting screw and nut	215 N-m 22 kgf-m 160 ft-lbs
	Rear wheel mounting stud bolt	98.1 to 112.8 N-m 10.0 to 11.5 kgf-m 72.3 to 83.2 ft-lbs

W1187806

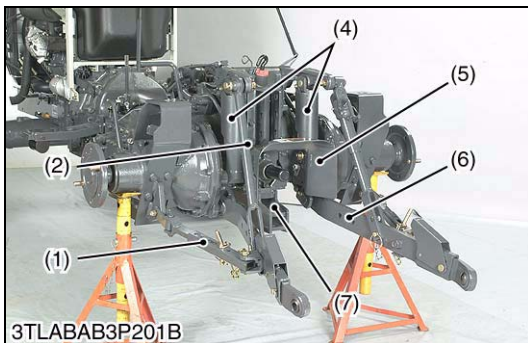

#### ROPS, 3 Point Linkages, Hydraulic Cylinders and Others

1. Remove the top link.
2. Remove the lift rods (2), lower links (6) and check chain (1) as a unit.
3. Remove the PTO shaft cover (5).
4. Remove the drawbar frame (7).
5. Disconnect the hydraulic cylinder hoses (8) and return hoses (10) at the rear hydraulic block (9).
6. Remove the two pins and remove the hydraulic cylinders (4).
7. Disconnect the brake rods.

#### (When reassembling)

- Apply grease to the lower link pins and hydraulic cylinder pins.

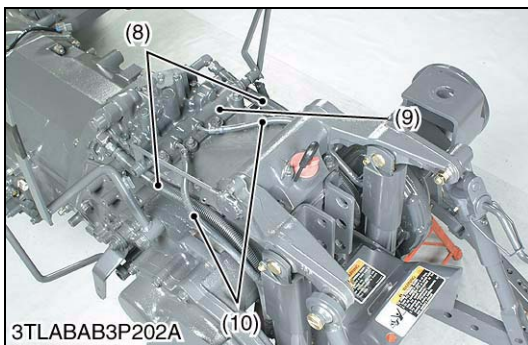

Tightening torque	Lift arm pin mounting nut	77.5 to 90.2 N-m 7.9 to 9.2 kgf-m 57.1 to 66.5 ft-lbs
	Lift arm pin lock nut	62.8 to 72.6 N-m 6.4 to 7.4 kgf-m 46.3 to 53.5 ft-lbs
	Drawbar frame mounting screw (M12)	77.5 to 90.2 N-m 7.9 to 9.2 kgf-m 57.1 to 66.5 ft-lbs
	Drawbar frame mounting screw (M14)	167 to 196 N-m 17.0 to 20.0 kgf-m 123 to 145 ft-lbs
	Hydraulic cylinder hose	34.3 to 48.1 N-m 3.5 to 4.9 kgf-m 25.3 to 35.4 ft-lbs

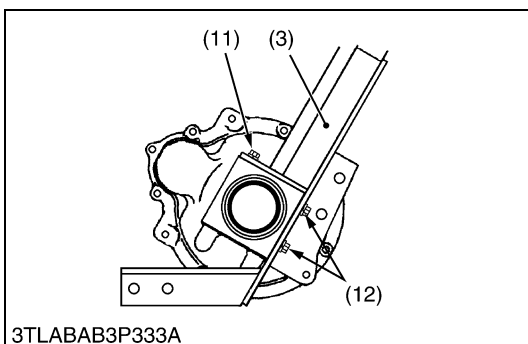

- |                        |                             |
|------------------------|-----------------------------|
| (1) Check Chain        | (7) Hydraulic Cylinder Hose |
| (2) Lift Rod           | (8) Rear Hydraulic Block    |
| (3) Hydraulic Cylinder | (9) Return Hose             |
| (4) PTO Shaft Cover    | (10) Screw (M14 × 155)      |
| (5) Lower Link         | (11) Screw (M14 × 30)       |
| (6) Drawbar Frame      |                             |

W1189095



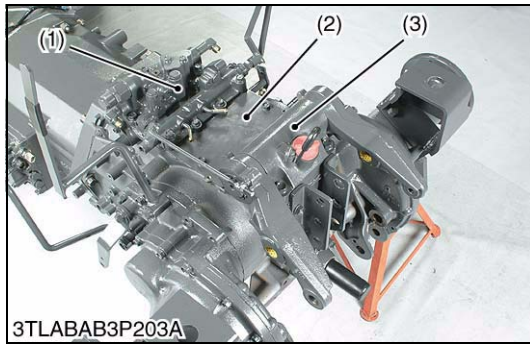

**Rear Hydraulic Block and Lift Arm Support**

1. Remove the GST delivery pipe. (Refer to 3-S59.)
2. Loosen the main delivery pipe support screw and disconnect the main delivery pipe at the rear hydraulic block (1). (Refer to 3-S59.)
3. Remove the rear hydraulic block (1), cover (2) and lift arm support (3) as a unit.

**(When reassembling)**

- Apply liquid gasket (Three Bond 1208D or equivalent) to joint face of the differential case and cover (2).

Tightening torque	Joint bolt for main delivery pipe to rear hydraulic block	49 to 69 N·m 5.0 to 7.0 kgf·m 36.1 to 50.6 ft-lbs
	Joint bolt for GST delivery pipe	34 to 39 N·m 3.5 to 4.0 kgf·m 25.3 to 28.9 ft-lbs

(1) Rear Hydraulic Block  
(2) Cover

(3) Lift Arm Support

W1054122



**Rear Axle**

1. Separate the rear axle case from brake case.

**(When reassembling)**

- Apply liquid gasket (Three Bond 1208D or equivalent) to joint face of the rear axle and brake case.

Tightening torque	Rear axle case mounting screw and nut	M10 screw and nut (7T)	48.1 to 55.9 N·m 4.9 to 5.7 kgf·m 35.4 to 41.2 ft-lbs
		Stud bolt	24.5 to 31.4 N·m 2.5 to 3.2 kgf·m 18.1 to 23.1 ft-lbs
		M10 nut (9T)	60.8 to 70.6 N·m 6.2 to 7.2 kgf·m 44.9 to 52.1 ft-lbs
		M12 screw	77.5 to 90.2 N·m 7.9 to 9.2 kgf·m 57.1 to 66.5 ft-lbs

W1054206

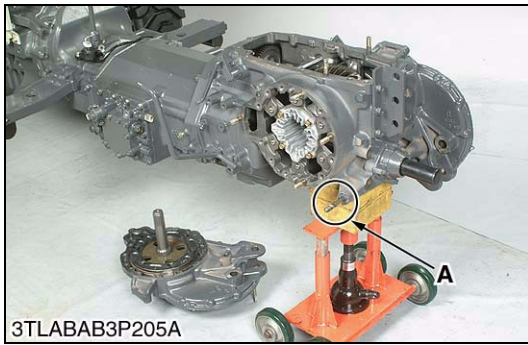

### Brake Case

1. Remove the creep gear shift lever and its fulcrum screw. (If equipped.)
2. Remove the brake case mounting screws and nuts.
3. Separate the brake case, tapping the brake case lever lightly.

#### (When reassembling)

- Apply grease to the steel ball seats. (Do not grease excessively.)
- Apply liquid gasket (Three Bond 1208D or equivalent) to joint face of the brake case and transmission case.
- Be sure to apply liquid gasket to **A** position.
- Be sure to fix the brake cam and cam plate.
- Before installing the brake case to the transmission case, install the cam plate to the transmission case.

Tightening torque	Brake case mounting stud bolt	29.4 to 49.0 N·m 3.0 to 5.0 kgf·m 21.7 to 36.1 ft-lbs
	Brake case mounting screw and nut	77.5 to 90.2 N·m 7.9 to 9.2 kgf·m 57.1 to 66.5 ft-lbs
	Lever fulcrum screw	62.8 to 72.5 N·m 6.4 to 7.4 kgf·m 46.3 to 53.5 t-lbs

W10543450

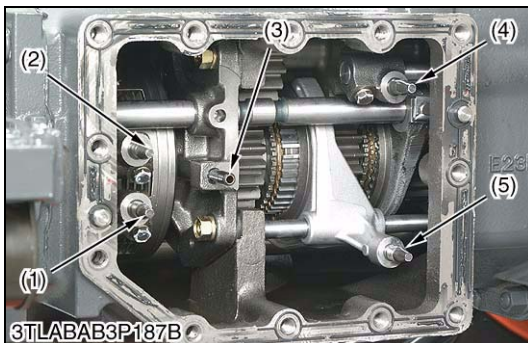

### GST Valve Assembly

1. Remove the GST valve assembly with using two jack bolts.
2. Remove the shift pin (4).

#### ■ NOTE

- **Do not fall down the shuttle check pin while disassembling.**

#### (When reassembling)

- Place the 1-2 (1) and 3-4 (2) shift pins at **neutral** position, sub-range shift pin (5) at **Hi** position (rearward) and main range shift pin (4) at **L** position (forward), and then assemble the GST valve.
- Be sure to match the each shift pin and shift piston.
- Install the GST valve by hand, and then tighten the screws. Do not use the hummer.
- Apply liquid gasket (Three Bond 1208D or equivalent) to joint face of the GST valve assembly.
- Replace the pipe (3) with new one, if damaged.

Tightening torque	GST valve mounting screw	42.2 to 48.1 N·m 4.3 to 4.9 kgf·m 31.1 to 35.4 ft-lbs
	Shift pin mounting screw	12.7 to 14.7 N·m 1.3 to 1.5 kgf·m 9.4 to 10.8 ft-lbs

- (1) 1-2 Shift Pin  
(2) 3-4 Shift Pin  
(3) Pipe

- (4) Main Range Shift Pin  
(5) Sub-range Shift Pin

W1194627



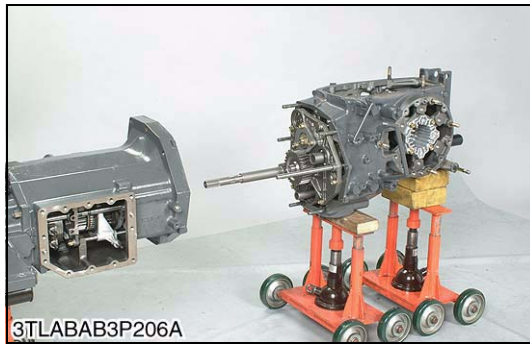

**Separating Mid Case and Transmission Case**

1. Separate the mid case and transmission case after removing their mounting screws and nut.

**(When reassembling)**

- Confirm to insert the PTO shaft to PTO clutch firmly, turning the PTO shaft.
- Confirm to insert the front wheel drive shaft to coupling firmly.
- Apply liquid gasket (Three Bond 1208D or equivalent) to joint face of the mid case and transmission case.

Tightening torque	Mid case and transmission case mounting screw	77.5 to 90.2 N·m 7.9 to 9.2 kgf·m 57.1 to 66.5 ft-lbs
	Mid case and transmission case mounting nut	102.9 to 117.6 N·m 10.5 to 12.0 kgf·m 75.9 to 86.8 ft-lbs
	Mid case and transmission case mounting stud bolt	39.2 to 49.0 N·m 4.0 to 5.0 kgf·m 28.9 to 36.2 ft-lbs

W1054481

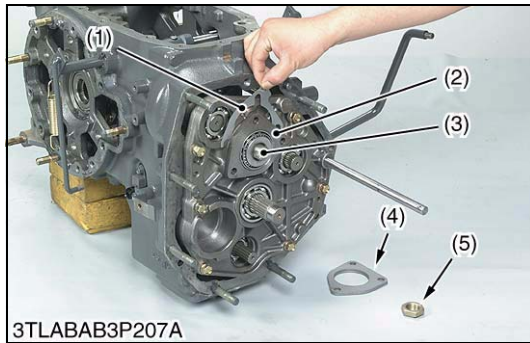

**Pinion Bearing Cover**

1. Remove the stake of lock nut (5).
2. Lock the turning of spiral bevel pinion and remove the lock nut (5).
3. Remove the pinion bearing case mounting screws.
4. Take out the pinion bearing cover (4) and shims (1).

**(When reassembling)**

- Make sure of the number of shims in the pinion bearing case.
- Replace the lock nut (5) with a new one, and stake the lock nut firmly after installing the parts on the shaft.

Tightening torque	Lock nut	147 to 196 N·m 15 to 20 kgf·m 108 to 145 ft-lbs
	Pinion bearing case mounting screw	39.2 to 44.1 N·m 4.0 to 4.5 kgf·m 28.9 to 32.5 ft-lbs

- (1) Shim
- (2) Pinion Bearing Case
- (3) Spiral Bevel Pinion Shaft
- (4) Pinion Bearing Cover
- (5) Lock Nut

W1054717

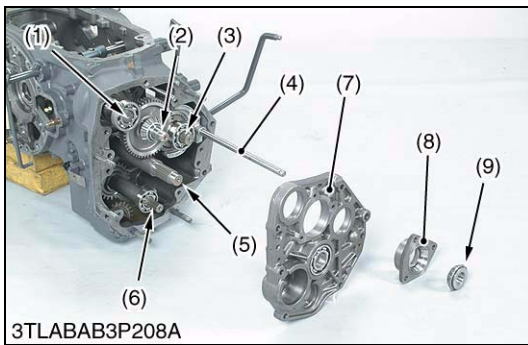

### Transmission Bearing Holder

1. Remove the transmission bearing holder mounting screws.
2. Jack up the bearing holder (7) by using the two jack screws until the taper roller bearing (9) can be removed.

#### NOTE

- Jack up the bearing holder while hitting the two shafts (2) (5) by copper hammer or soft hammer.

3. Jack up more and remove the transmission bearing holder (7).

#### (When reassembling)

- Tap in the transmission bearing holder with soft hammer until contact to transmission case, and then tighten the screws to specified torque.

Tightening torque	Transmission bearing holder mounting screw	48.1 to 55.9 N·m 4.9 to 5.7 kgf·m 35.5 to 41.2 ft·lbs

- (1) Creep Gear Shaft (Creep Gear Type) (6) Front Wheel Drive Shaft  
 (2) Spiral Bevel Pinion Shaft (7) Transmission Bearing Holder  
 (3) Range Gear Shaft (8) Pinion Bearing Case  
 (4) Shift Fork Rod for Range Gear Shift (9) Taper Roller Bearing  
 (5) PTO Drive Shaft

W1054992

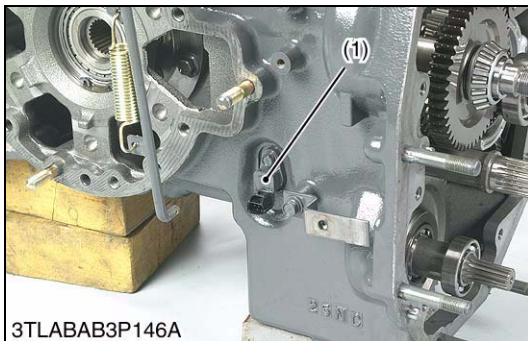

### Shaft Assemblies

1. Remove the traveling speed sensor (1).
2. Remove the external snap ring (3) of the creep gear shaft (4) to the rear.
3. Take out the range gear shaft assembly (8) with the shift fork rod (9).
4. Take out the creep shaft assembly (4) and spiral bevel pinion shaft assembly (7) with shift fork (10) and shift fork rod (11).
5. Take out the PTO drive shaft assembly (6) and front wheel drive shaft assembly (5).

- (1) Traveling Speed Sensor (7) Spiral Bevel Pinion Shaft  
 (2) Creep Gear (8) Range Gear Shaft  
 (3) External Snap Ring (9) Shift Fork Rod  
 (4) Creep Gear Shaft (10) Shift Fork  
 (5) Front Wheel Drive Shaft (11) Shift Fork Rod  
 (6) PTO Drive Shaft

W1198652

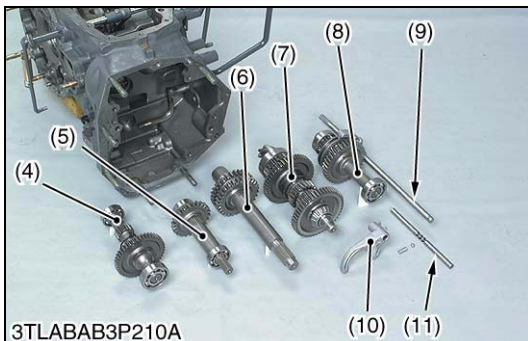
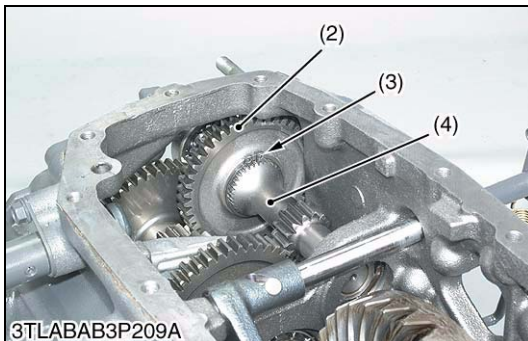

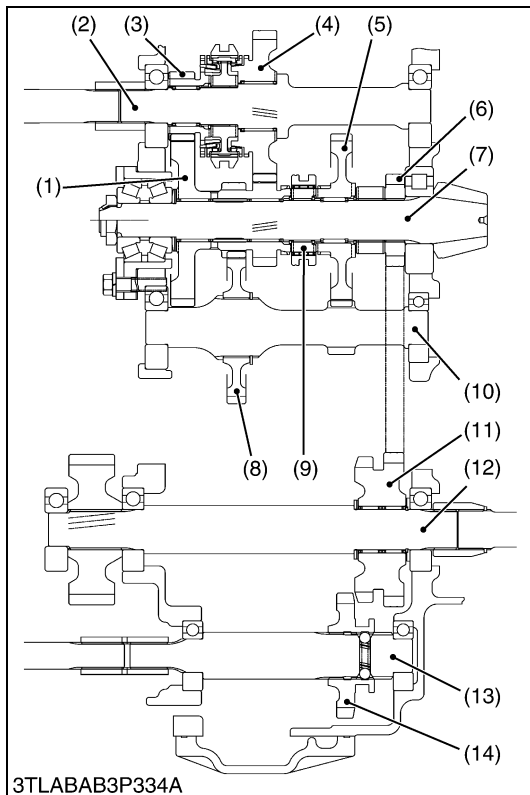

**Disassembling Shaft Assemblies**

1. Disassemble the each shaft referring to the figure.

- |                               |                              |
|-------------------------------|------------------------------|
| (1) 49T-19T-20T Gear          | (8) 44T Gear                 |
| (2) Range Gear Shaft          | (9) Shifter for Creep Shift  |
| (3) 17T Gear                  | (10) Creep Shaft             |
| (4) 35T Gear                  | (11) 29T-30T Gear ( L4630)   |
| (5) 50T Gear                  | 29T-32T Gear (L5030)         |
| (6) 18T Gear (L4630)          | (12) PTO Drive Shaft         |
| 17T Gear (L5030)              | (13) Front Wheel Drive Shaft |
| (7) Spiral Bevel Pinion Shaft | (14) 24T Shifter Gear        |

W1055343

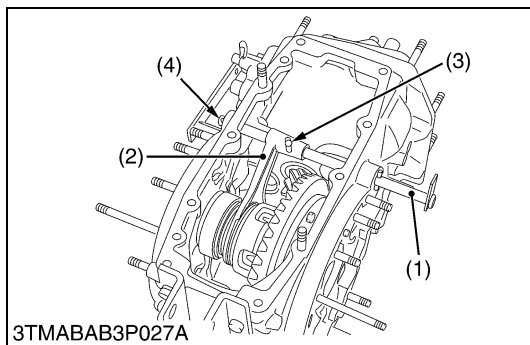

**Differential Lock Shift Fork**

1. Tap out the left side spring pin (4).
2. Remove the cotter pin and take out the clevis pin (3).
3. Draw out the differential lock fork shaft (1) and take out the differential lock shift fork (2).

**(When reassembling)**

- Apply grease to the left and right oil seals on the transmission case.
- Insert the clevis pin (3) from the top and install the washer and cotter pin.
- Tap in the spring pin (4) so that its split portion **a** may face outward as shown in the figure.

- |                                  |                          |
|----------------------------------|--------------------------|
| (1) Differential Lock Fork Shaft | <b>a : Split Portion</b> |
| (2) Differential Lock Shift Fork |                          |
| (3) Clevis Pin                   |                          |
| (4) Spring Pin                   |                          |

W12034180

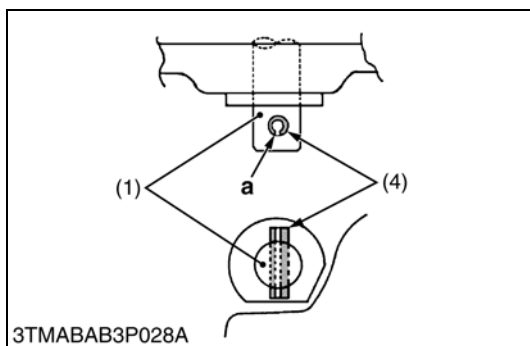

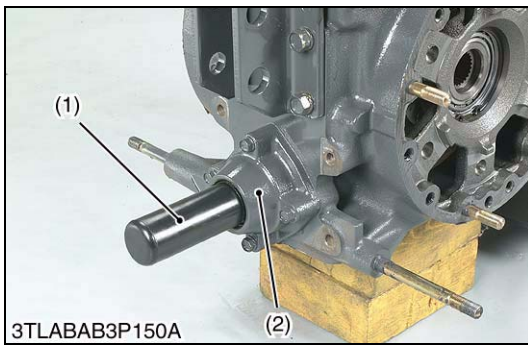

**PTO Shaft**

1. Remove the PTO shaft cover.
2. Remove the bearing case mounting screws, and draw out the PTO shaft (1) with bearing case (2).
3. Remove the internal snap ring (3).
4. Top out the PTO shaft (1) to the front.

**(When reassembling)**

- If the lock nut (6) was removed, replace it with a new one. After replacing, be sure to stake it firmly.
- Install the slinger (7) firmly.
- Apply grease to the oil seal (4) and install it, noting its direction.

Tightening torque	Lock nut	147 to 196 N·m 15 to 20 kgf·m 108 to 145 ft·lbs
	Bearing case mounting screw	23.5 to 27.5 N·m 2.4 to 2.8 kgf·m 17.4 to 20.3 ft·lbs

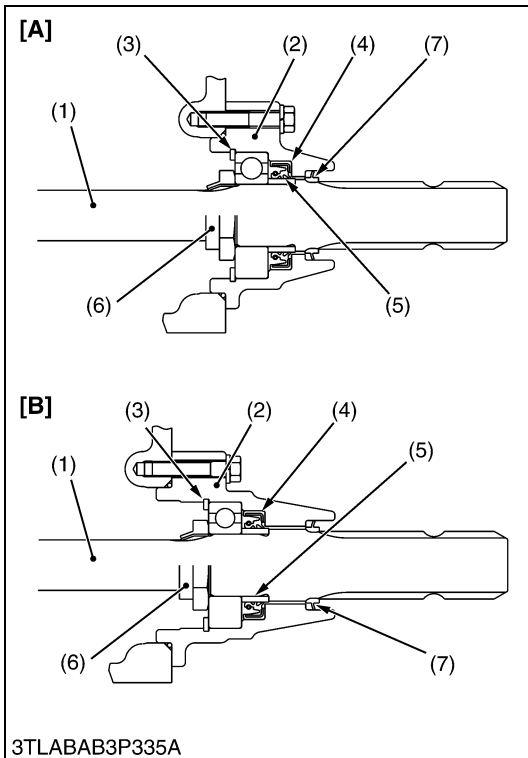

- (1) PTO Shaft
- (2) Bearing Case
- (3) Internal Snap Ring
- (4) Oil Seal
- (5) Oil Seal Collar
- (6) Lock Nut
- (7) Slinger

[A] L4630  
[B] L5030

W12044640

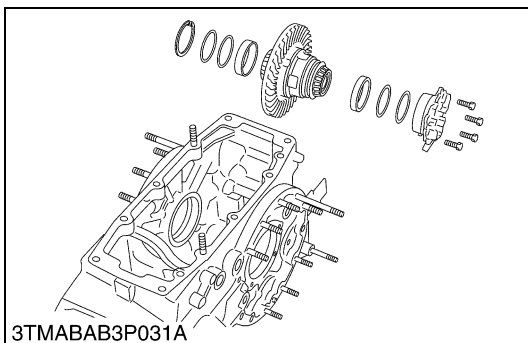

**Differential Gear Assembly**

1. Remove the differential support, noting the number of left shims.
2. Take out the differential gear assembly, noting the number of right shims.

**(When reassembling)**

- Check the spiral bevel gear for wear or damage. If it is no longer serviceable, replace it. Then, also replace the spiral bevel pinion.
- Use same number of shims as before disassembling.

Tightening torque	Differential support mounting screw	48.1 to 55.9 N·m 4.9 to 5.7 kgf·m 35.4 to 41.2 ft·lbs
-------------------	-------------------------------------	---

W12055450

**Disassembling Differential Gears**

1. See page 3-S41, S42.

W1056552



**(D) Regulating Valve**



**Front Grille, Skirt and Battery Cable**

1. Open the bonnet and disconnect the battery negative cable.
2. Disconnect the head light connector and remove the front grille (3).
3. Remove the skirt RH (2).

- (1) Bonnet
- (2) Skirt RH
- (3) Front Grille

W1056678

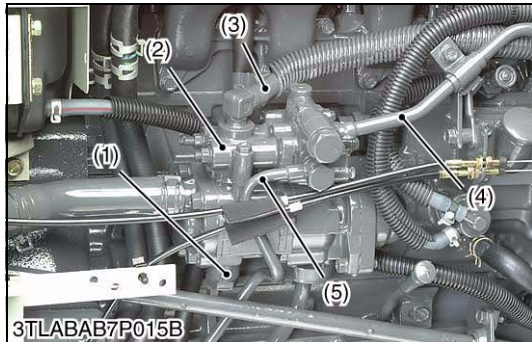

**Hydraulic Pipes and Regulating Valve Assembly**

1. Disconnect the GST delivery pipe (5), power steering return hose (3) and power steering delivery pipe (4) from regulating valve assembly (2).
2. Remove the delivery pipe (1).
3. Loosen and remove the regulating valve mounting screws.
4. Take out the regulating valve assembly (2) from the power steering hydraulic pump (7).

**(When reassembling)**

- Install the copper washers firmly.
- Apply grease to the O-ring (6) and take care not to damage it.

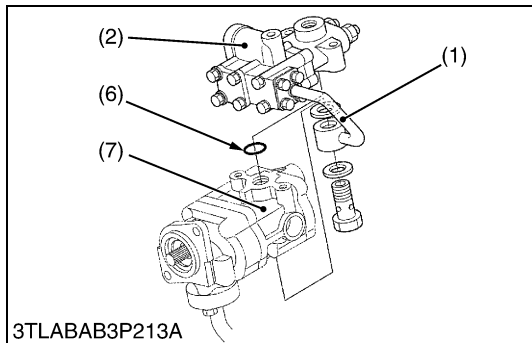

Tightening torque	Joint bolt for GST delivery pipe (3) and regulating valve	34.3 to 39.2 N·m 3.5 to 4.0 kgf·m 25.3 to 28.9 ft·lbs
	Joint bolt for power steering delivery hose (2) and regulating valve	49.0 to 68.6 N·m 5.0 to 7.0 kgf·m 36.2 to 50.6 ft·lbs
	Joint bolt for delivery pipe (5) and hydraulic pump	39.3 to 49.0 N·m 4.0 to 5.0 kgf·m 29.0 to 36.2 ft·lbs
	Regulating valve mounting screws	17.6 to 20.6 N·m 1.8 to 2.1 kgf·m 13.0 to 15.2 ft·lbs

- (1) Delivery Pipe
- (2) Regulating Valve Assembly
- (3) Power Steering Return Hose
- (4) Power Steering Delivery Pipe
- (5) GST Delivery Pipe
- (6) O-ring
- (7) Power Steering Hydraulic Pump

W1056783

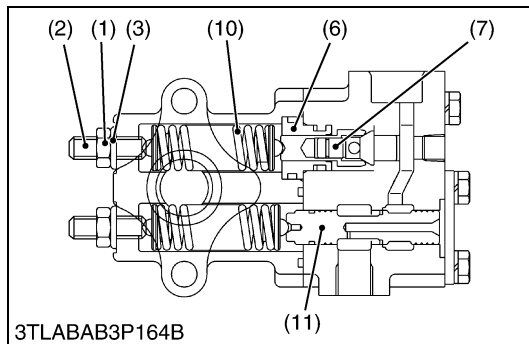
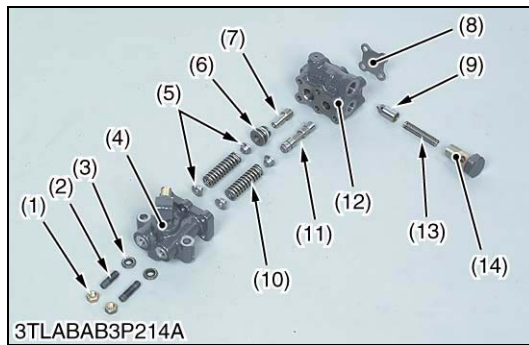

### Disassembling Regulating Valve

#### NOTE

- The regulating valve has been precisely machined and assembled. It is advisable not to disassemble it as long as there is no necessary.

- Remove the plate (8) and take out reducing spool (11), spring retainer (5) and spring (10).
- Separate the regulating valve case (12) and support (4).
- Take out the bush (6) and poppet (7).
- Remove the joint bolt (14), and then take out the spring (13) and the poppet (9).
- Take out the spring retainer (5) and spring (10).

#### (When reassembling)

- Take care not to damage the O-rings.

Tightening torque	Joint bolt (14)	49.0 to 58.8 N·m 5.0 to 6.0 kgf·m 36.2 to 43.4 ft-lbs
	Plate (8)	9.8 N·m 1.0 kgf·m 7.2 ft-lbs
	Regulating valve case and support mounting screws	9.8 N·m 1.0 kgf·m 7.2 ft-lbs

- |                        |                            |
|------------------------|----------------------------|
| (1) Nut                | (8) Plate                  |
| (2) Adjustor           | (9) Poppet                 |
| (3) Washer with Rubber | (10) Spring                |
| (4) Support            | (11) Reducing Spool        |
| (5) Spring Retainer    | (12) Regulating Valve Case |
| (6) Bush               | (13) Spring                |
| (7) Poppet             | (14) Joint Bolt            |

W1057149

### (E) GST Valve Assembly

#### NOTE

- The GST valve has been precisely machined and assembled. It is advisable not to disassemble it. If unavoidably necessary to do it, take the following precautions.

- Tighten up the screws and nuts to their specified torques.
- Be sure to clean the disassembled parts and dry them up with compressed air.
- Do not wear any gloves other than rubber ones not use waste cloth. This is important for keeping the parts clean and free from rust.
- Be careful not to drop the parts on the floor or workbench. Check any part, if dropped, for hit mark, scratch and burr.
- Be sure to use a rubber or plastic hammer for reassembling.
- Do not use a wire brush nor polish any part with sandpaper.
- Apply super UDT oil to the O-rings and oil seals before reassembling. Do not use any metal-cleaning liquid.

### Draining Transmission Fluid

- See page 3-S55.

W1057749



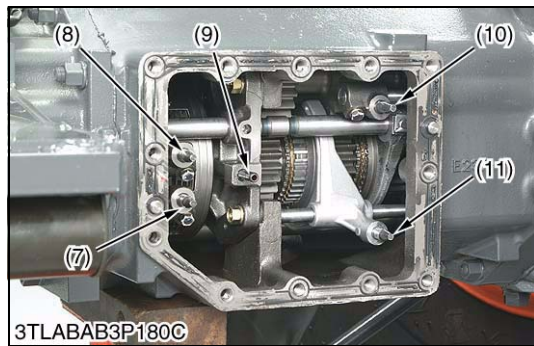
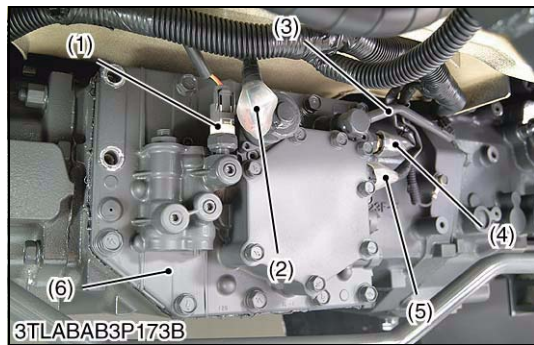

### GST Valve Assembly

1. Remove the GST valve cover.
2. Disconnect the pressure switch connector (1), proportional reducing valve connector (2) solenoid connector (4) and oil temperature sensor connector (5).
3. Disconnect the GST delivery pipe (3).
4. Remove the GST valve assembly (6) with using two jack bolts.

#### NOTE

- Do not fall down the shuttle check pin while assembling.
- (When reassembling)**
- Place the 1-2 shift pin (7) and the 3-4 shift pin (8) at **neutral** position, main range shift pin (10) at **L** position (forward) and sub-range pin (11) at **Hi** position (rearward), and then assemble the GST valve.
  - Be sure to match the each shift pin and shift piston.
  - Install the GST valve assembly (6) by hand, and then tighten the screws. Do not use the hummer.
  - Apply liquid gasket (Three Bond 1208D or equivalent) to joint face of the GST valve assembly.

Tightening torque	GST valve assembly mounting screw	42.2 to 48.1 N·m 4.3 to 4.9 kgf·m 31.1 to 35.4 ft·lbs
	Joint bolt for GST delivery pipe to GST valve	34.3 to 39.2 N·m 3.5 to 4.0 kgf·m 25.3 to 28.9 ft·lbs

- |   |                           |
|---|---------------------------|
| (1) Pressure Switch Connector             | (6) GST Valve Assembly    |
| (2) Proportional Reducing Valve Connector | (7) 1-2 Shift Pin         |
| (3) GST Delivery Pipe                     | (8) 3-4 Shift Pin         |
| (4) Oil Temperature Sensor Connector      | (9) Pipe                  |
| (5) Solenoid Valve Connector              | (10) Main Range Shift Pin |
|   | (11) Sub-range Shift Pin  |

W1057795

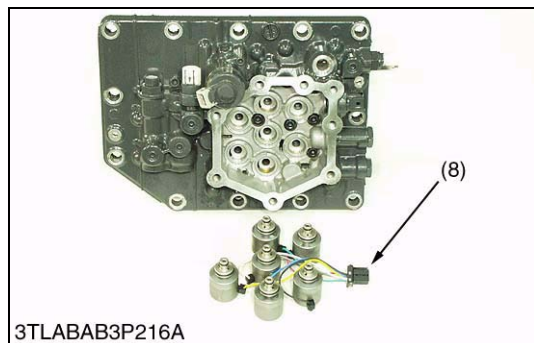
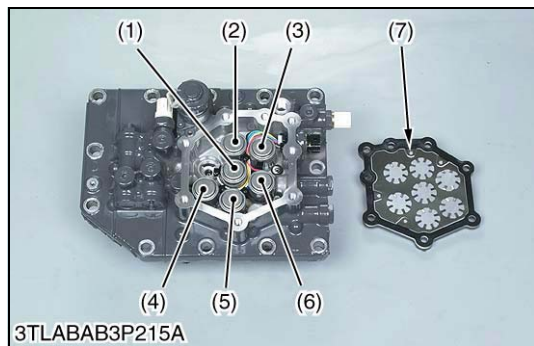

### Solenoid Valve

1. Remove the cover (7).
2. Disconnect the connector (8) and remove the solenoid valves.

#### (When reassembling)

- Be sure to install the each solenoid valve to their original positions as shown in the photo and table below.

No.	Solenoid Name	Color of wiring
(6)	Shift Solenoid 1 (1st shift)	Black
(1)	Shift Solenoid 2 (2nd shift)	White
(3)	Shift Solenoid 3 (3rd shift)	Red
(2)	Shift Solenoid 4 (4th shift)	Green
(5)	Shift Solenoid 5 (Sub-range shift)	Blue
(4)	Shift Solenoid 6 (Main range shift)	Yellow

- |                |                |
|----------------|----------------|
| (1) Solenoid 2 | (5) Solenoid 5 |
| (2) Solenoid 4 | (6) Solenoid 1 |
| (3) Solenoid 3 | (7) Cover      |
| (4) Solenoid 6 | (8) Connector  |

W1058270

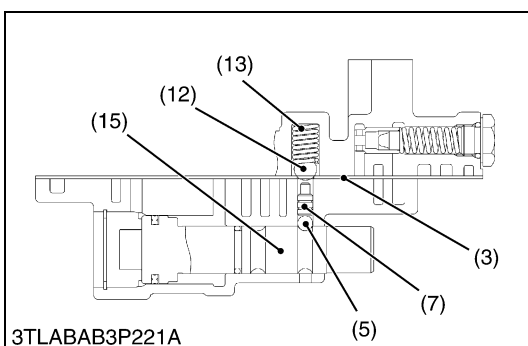
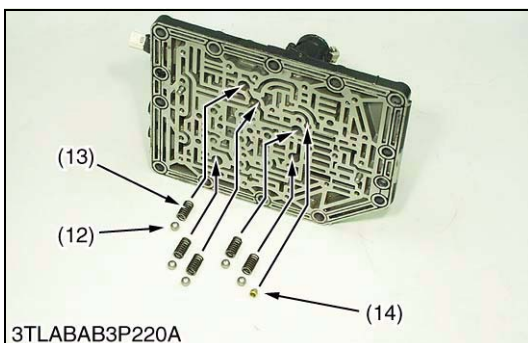
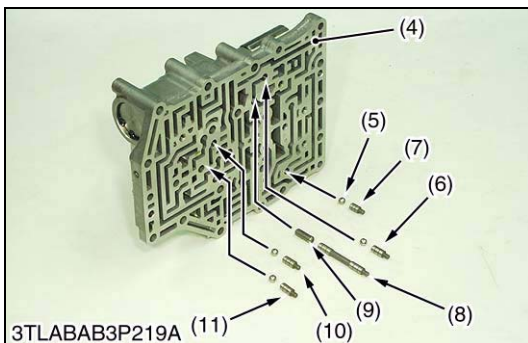
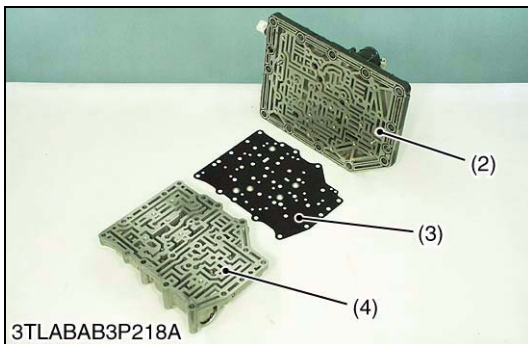
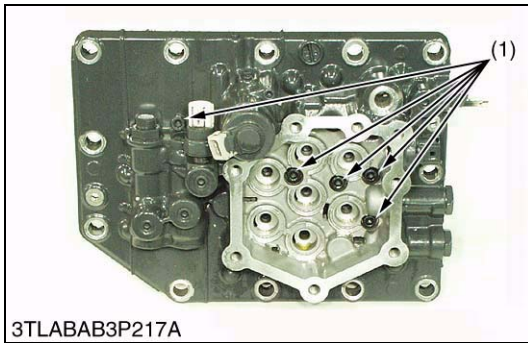

**Shift Check Valve**

1. Remove the lower body mounting hex. socket head cap screws (1).
2. Separate the upper body (2) and lower body (4).
3. Take out the 1-2, 3-4 shift check pin (10), (11), sub-range shift check pin (6), main range shift check pin (6), shuttle shift check pin (7), balls (5) and pin (9) from lower body (4).
4. Take out the springs (13), balls (12) and filter (14) from upper body (2).

**(When reassembling)**

- Take care so that only the main range shift check pin (6) is short length.

Tightening torque	Lower body mounting hex. socket head cap screw	9.8 to 10.8 N·m 1.0 to 1.1 kgf·m 7.2 to 8.0 ft·lbs
-------------------	--	--

- |                                |                          |
|--------------------------------|--------------------------|
| (1) Hex. Socket Head Cap Screw | (9) Shuttle Shift Pin    |
| (2) Upper Body                 | (10) 3-4 Shift Check Pin |
| (3) Plate                      | (11) 1-2 Shift Check Pin |
| (4) Lower Body                 | (12) Ball                |
| (5) Ball                       | (13) Spring              |
| (6) Main Range Shift Check Pin | (14) Filter              |
| (7) Sub-range Shift Check Pin  | (15) Shift Piston        |
| (8) Shuttle Shift Check Pin    |                          |

W1058592

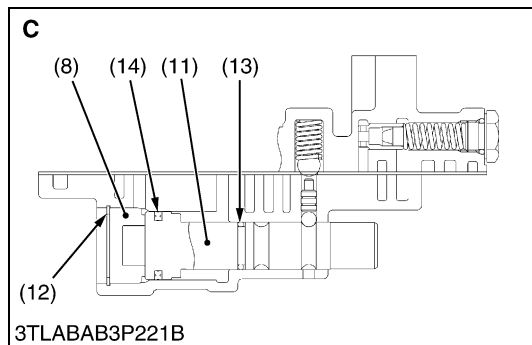
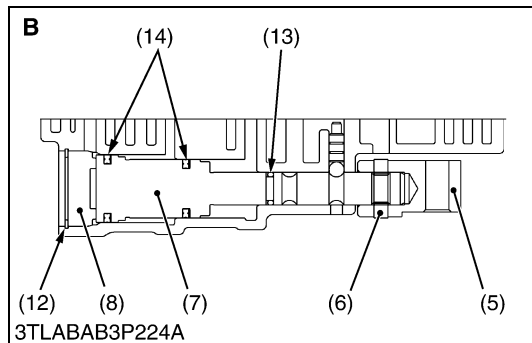
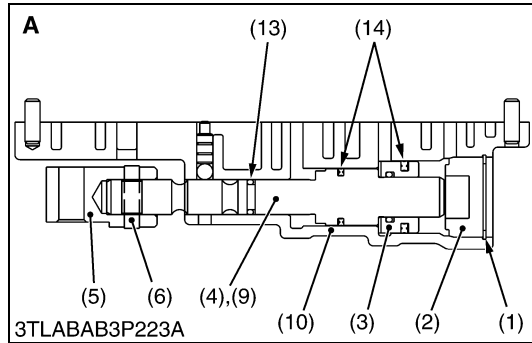
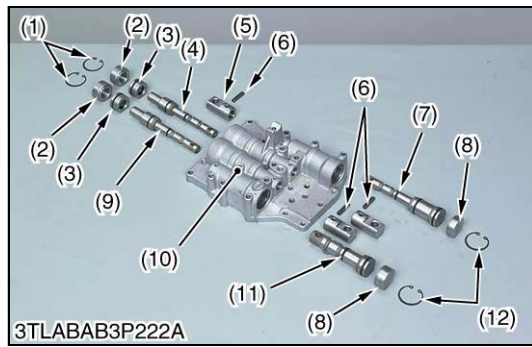

### Shift Piston

1. Separate the upper body, and lower body. (See page 3-S80.)
2. Tap out the spring pins (6), and remove the shifters (5).  
(For 1-2, 3-4 and sub-range shift piston)
3. Remove the internal snap ring (1) and cover (2), and then take out the shift piston (4), (9) with neutral piston (3).  
(For 1-2 and 3-4 shift piston)
4. Remove the internal snap ring (12) and cover (8), and then take out the shift piston (7), (11).  
(For main range and sub-range shift piston)

### (When reassembling)

- Take care not to damage the O-ring (13) and piston seal (14).

- |                            |                              |
|----------------------------|------------------------------|
| (1) Internal Snap Ring     | (10) Lower Body              |
| (2) Cover                  | (11) Main Range Shift Piston |
| (3) Neutral Piston         | (12) Internal Snap Ring      |
| (4) 3-4 Shift Piston       | (13) O-ring                  |
| (5) Shifter                | (14) Piston Seal             |
| (6) Spring Pin             |                              |
| (7) Sub-range Shift Piston |                              |
| (8) Cover                  |                              |
| (9) 1-2 Shift Piston       |                              |

**A : 1-2 and 3-4 Shift Piston**

**B : Sub-range Shift Piston**

**C : Main Range Shift Piston**

W1059069

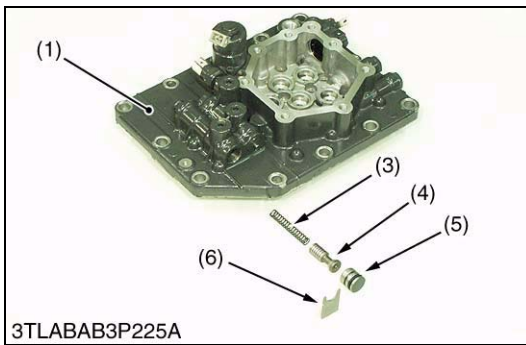

### Low-pass Valve

#### ■ IMPORTANT

- Do not adjust or remove the adjuster (2), otherwise the GST clutch engagement feeling will be changed.

If this valve is disassembled, be sure to check and adjust the low-pass pressure.

- Separate the upper body and lower body. (See page 3-S80.)
- Remove the plug (5).
- Remove the stopper plate (6) and remove the low-pass poppet (4) and spring (3).

- (1) Lock Nut  
(2) Adjustor  
(3) Spring

- (4) Low-pass Poppet  
(5) Plug  
(6) Stopper Plate

W1059505

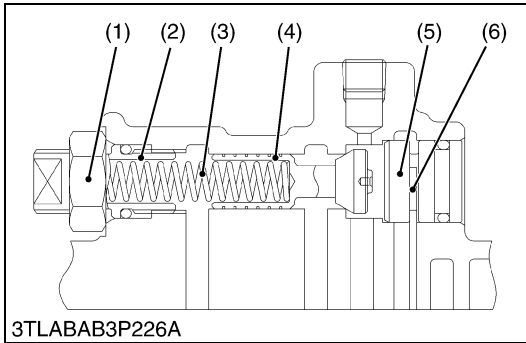

### Clutch Valve

- Separate the upper body and lower body. (See page 3-S80.)
- Remove the stopper plate (4) while pushing the plug (1).
- Take out the spool (2) and spring (3).

#### (When reassembling)

- Be careful about the direction of the spool (2) and the plugs (1) referring to the figure.

- (1) Plug  
(2) Spool

- (3) Spring  
(4) Stopper Plate

W1059735

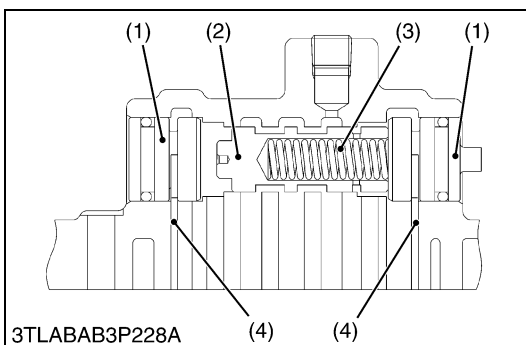
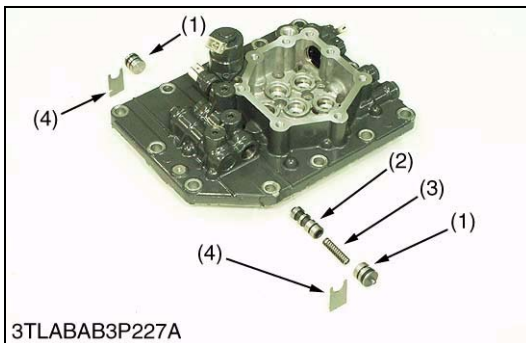



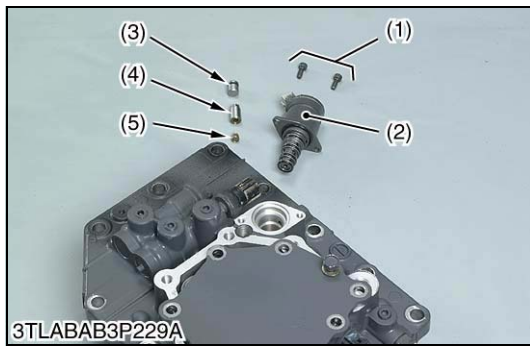

### Proportional Reducing Valve and Filter

1. Remove the valve mounting hex. socket head cap screws.
2. Remove the proportional reducing valve (2).
3. Remove the cover (6).
4. Take out the plug (3) and orifice support (4) with filter (5).

#### (When reassembling)

- Take care not to damage the O-ring.

- |                                 |                     |
|---------------------------------|---------------------|
| (1) Hex. Socket Head Cap Screw  | (4) Orifice Support |
| (2) Proportional Reducing Valve | (5) Filter          |
| (3) Plug                        | (6) Cover           |

W1059897

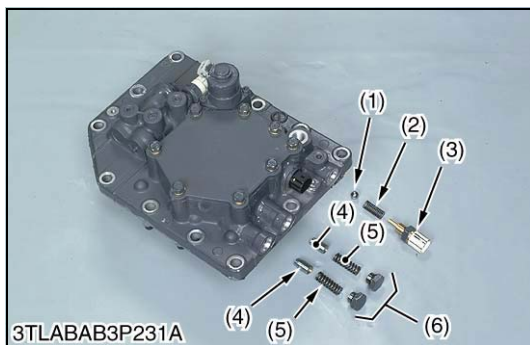
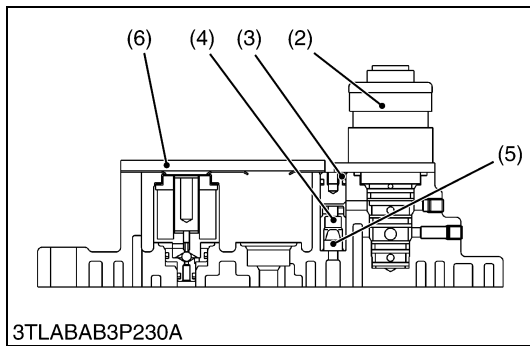

### Check Valve, Oil Temperature Sensor, Orifice and Filter

1. Remove the oil temperature sensor (3) and take out the spring (2) and ball (1).
2. Remove the plug (6), and take out the spring (5) and orifice plug (4) with filter (7).

#### (When reassembling)

- Be careful about the direction of the orifice support (4) and filter (7).

- |                            |            |
|----------------------------|------------|
| (1) Ball                   | (5) Spring |
| (2) Spring                 | (6) Plug   |
| (3) Oil Temperature Sensor | (7) Filter |
| (4) Orifice Support        |            |

W1060139

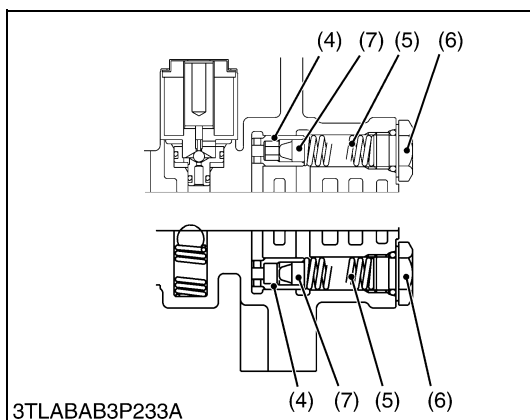
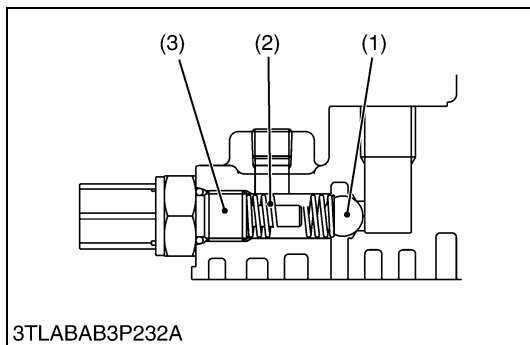

**(3) Servicing****(A) Bearing, Gear and Shaft**

See page 3-S43.

**(B) Synchronizer Gear**

See page 3-S44.

**(C) PTO Clutch**

See page 3-S45.

**(D) Differential Gears**

See page 3-S46 to 3-S48.

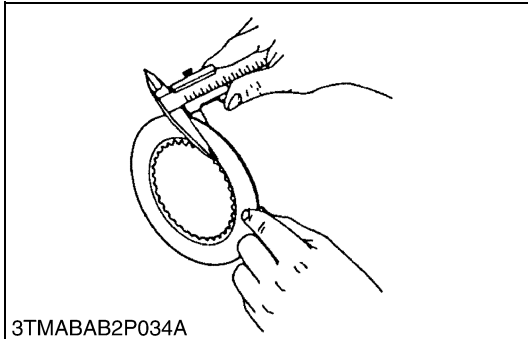
**(E) GST Clutch****Clutch Disc Wear**

1. Measure the thickness of GST clutch disc with vernier calipers.
2. If the thickness is less than the allowable limit, replace it.

Thickness of GST clutch disc	Factory spec.	2.55 to 2.65 mm 0.100 to 0.104 in.
	Allowable limit	2.50 mm 0.098 in.

W1060836

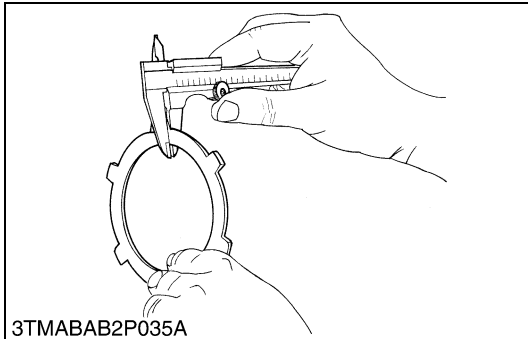
**Steel Plate Wear**

1. Measure the thickness of GST steel plate with vernier calipers.
2. If the thickness is less than the allowable limit, replace it.

Thickness of GST steel plate	Factory spec.	1.55 to 1.65 mm 0.061 to 0.065 in.
	Allowable limit	1.50 mm 0.059 in.

W1061099

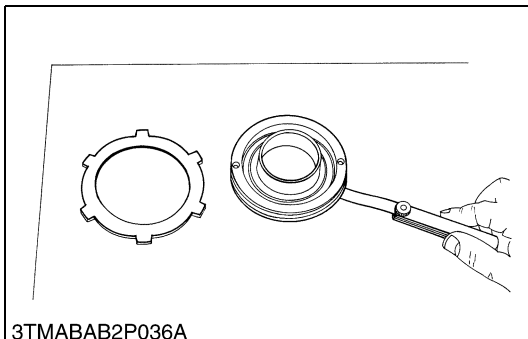
**Flatness of Piston and Steel Plate**

1. Place the part on a surface plate.
2. Check it unable to insert a feeler gauge (allowable limit size) underneath it at least four points.
3. If the gauge can be inserted, replace it.

Flatness of GST piston	Allowable limit	0.15 mm 0.006 in.
------------------------	-----------------	----------------------

Flatness of GST steel plate	Allowable limit	0.30 mm 0.012 in.
-----------------------------	-----------------	----------------------

W1061290

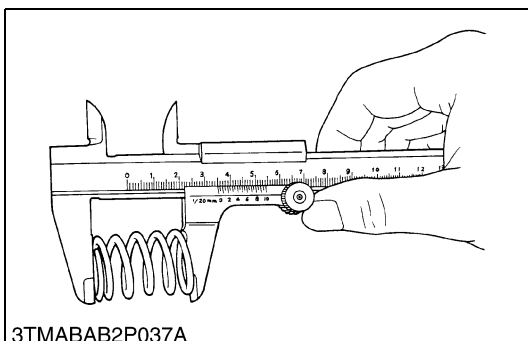
**Piston Return Spring Free Length**

1. Measure the free length of spring with vernier calipers.
2. If the measurement is less than the allowable limit, replace it.

Piston return spring free length	Factory spec.	19.9 to 20.1 mm 0.78 to 0.79 in.
	Allowable limit	18.0 mm 0.71 in.

W1060662



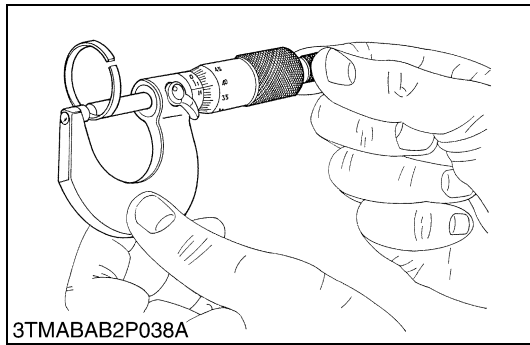

### Thickness of Seal Ring

1. Measure the thickness of seal rings (1) with an outside micrometer.
2. If the measurement is less than the allowable limit, replace it.

Thickness of seal ring	Factory spec.	2.45 to 2.50 mm 0.096 to 0.098 in.
	Allowable limit	2.0 mm 0.0079 in.

(1) Seal Ring

W1061536

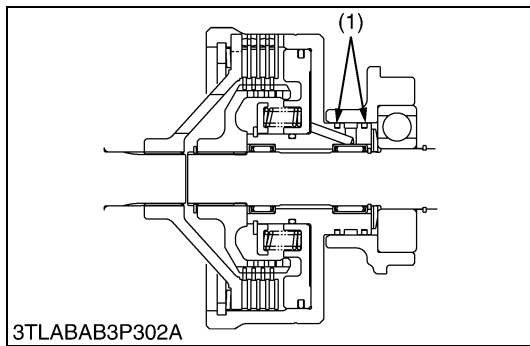

### [3] HYDROSTATIC TRANSMISSION (HST) MODEL

#### (1) Checking and Adjusting

#### (A) Electrical Adjusting [Adjustment with Electronic Instrument Panel (IntelliPanel)]

##### ■ NOTE

- Before executing the following fine-adjustment, refer to “Testing, Setting and Adjusting by Electronic Instrument Panel” of an Electrical System. (Refer to page 9-S12.)

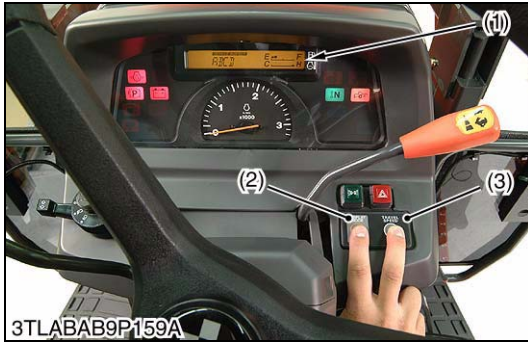

3TLABAB9P159A

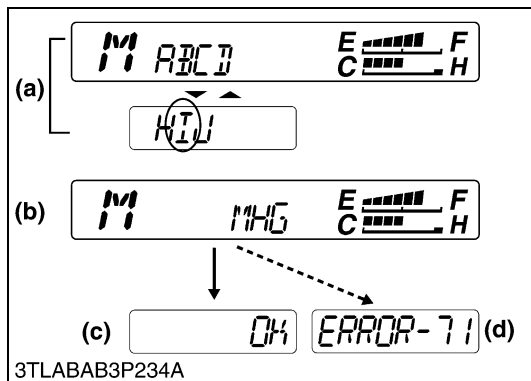

3TLABAB3P234A

#### Adjustment of HST Range Gear Shift Lever Sensor

##### ■ NOTE

- When the electronic instrument panel or range gear shift sensor was replaced, this adjustment is required.

1. Set the range gear shift lever to the **M** position.
2. Push down both the display mode switch (2) and the travel speed switch (3) at once, continue holding switches, and then turn the main switch to **ON** position.
3. The “**Mode Selection Display**” (a) is indicated on the LCD (1). And release the switches.
4. Press the display mode switch (2) to move the flashing part, and flash the “**I**”.
5. Hold down the display mode switch (2) for more than 2 seconds at this condition, and the buzzer rings and Mode **I** is selected.
6. “**MHG**” is displayed (b), and the existing symbol setting is flashing.
7. Press the display mode switch (2) to move the flashing part, and flash the “**H**” of the HST model.
8. Hold down the display mode switch (2) for more than 2 seconds at this condition, and the buzzer rings.
9. “**OK**” is displayed (c) : Lever sensor voltage is as specified.
10. “**ERROR 71**” is displayed (d) : Lever sensor voltage is not specified.

In this case;

- Check to see that the range gear shift lever is at **M** position.
- Check the lever sensor voltage in the Test Mode (Mode “**A**”) (see page 9-S13). If out of specification, replace the sensor.

- (1) Liquid Crystal Display (LCD)  
 (2) Display Mode Switch  
 (3) Travel Speed Switch

- (a) **Mode Selection Display**  
 (b) **Information Display**  
 (c) **Correct Preserving Display**  
 (d) **Error Display**

W1061720

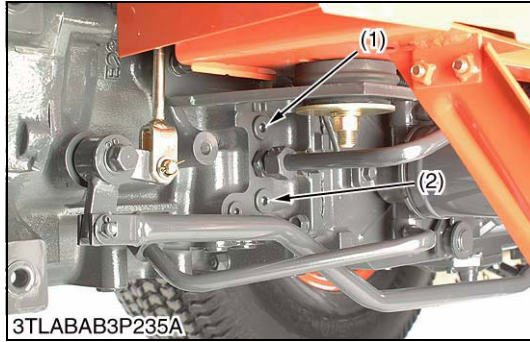
**(B) Hydraulic Checking and Adjusting****Checking High Pressure Relief Valve Pressure****⚠ CAUTION**

- **When checking, park the machine on flat ground, apply the parking brake.**
1. Remove the hex. socket head plug from **P1** or **P2** port. (**P2** is for forward and **P1** is for reverse.)
  2. Assemble adaptor **C** (07916-50371) and threaded joint (07916-50341) with the gasket between them.
  3. Install the assemble adaptor **C** and threaded joint to **P2** (forward) or **P1** (reverse) port.
  4. Install the cable, threaded joint in relief valve set pressure tester and high pressure gauge to threaded joint in order.
  5. Check to see that parking brake is applied.
  6. Run the engine at maximum speed.
  7. Place the range gear shift lever in **H** position.
  8. Depress the HST pedal, and measure the check and high pressure relief valve pressure.
  9. If the measurement is not within the factory specification, check the check and high relief valve assembly. (See page 3-S103.)

Check and high relief pressure (Oil temperature at 40 to 60 °C (104 to 140 °F))	Factory spec.	33.3 to 36.3 MPa 340 to 370 kgf/cm <sup>2</sup> 4836 to 5262 psi
---	---------------	--

**■ IMPORTANT**

- **Measure quickly so that the relief valve may not be in operation more than 10 seconds.**

**■ NOTE**

- **High pressure gauge is 40 MPa (400 kgf/cm<sup>2</sup>, 5800 psi) full scale.**

**(When reassembling)**

- Install the hex. socket head plug to the port with O-ring.

(1) **P1** Port (for Reverse)(2) **P2** Port (for Forward)

W1012199

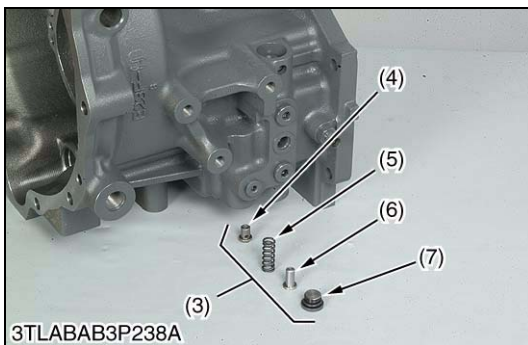
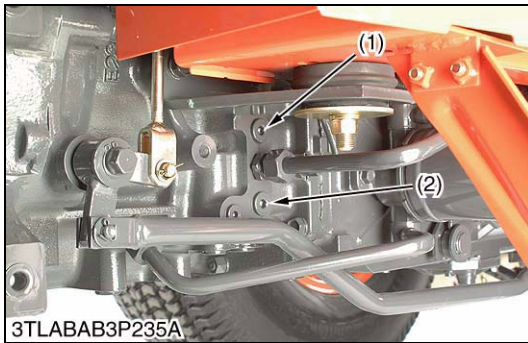

## Checking Charge Relief Pressure

### ⚠ CAUTION

- When checking, park the machine on flat ground, apply the parking brake.

### ■ NOTE

- Use a new transmission oil filter.

1. Remove the hex. socket head plug from P2 (or P1) port.
2. Assemble adaptor **58** (07916-52391) and thread joint (07916-50341) with the gasket between them.
3. Install the assembled adaptor **58** and thread joint to P2 port.
4. Install the cable, thread joint in relief valve set pressure tester and low pressure gauge to threaded joint in order.
5. Place the range gear shift lever in neutral.
6. Run the engine at maximum speed.
7. Release the HST pedal to set in neutral, and measure the charge pressure.
8. If the measurement is not within the factory specifications, check charge relief valve (3) (See page 3-S103) or adjust with adjusting shim.

### ■ NOTE

- Adjusting shim is located on between spring guide (6) and plug (7).

### (Reference)

- Thickness of adjusting shim : 0.5 mm (0.02 in.)
- Pressure change per 0.5 mm (0.02 in.) of shim :  
Approx. 61.8 kPa  
0.68 kgf/cm<sup>2</sup>  
8.97 psi

Charge pressure (oil temperature at 50 to 60 °C (122 to 140 °F))	Factory spec.	2.26 to 2.45 MPa 23 to 25 kgf/cm <sup>2</sup> 327 to 355 psi
--	---------------	--

### ■ NOTE

- Low pressure gauge is 5 MPa (50 kgf/cm<sup>2</sup>, 711 psi) full scale.

- |                         |                  |
|-------------------------|------------------|
| (1) P1 Port             | (5) Spring       |
| (2) P2 Port             | (6) Spring Guide |
| (3) Charge Relief Valve | (7) Plug         |
| (4) Poppet              |                  |

W1012608

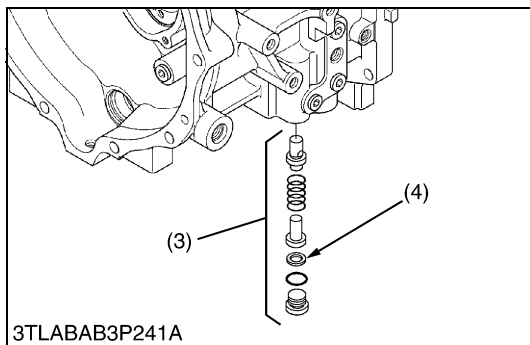
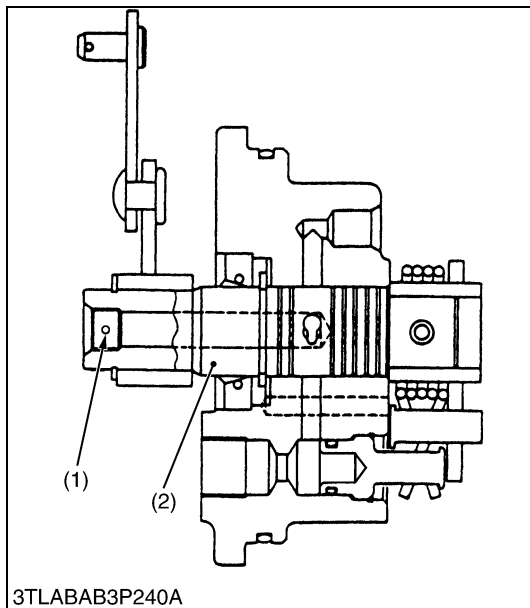
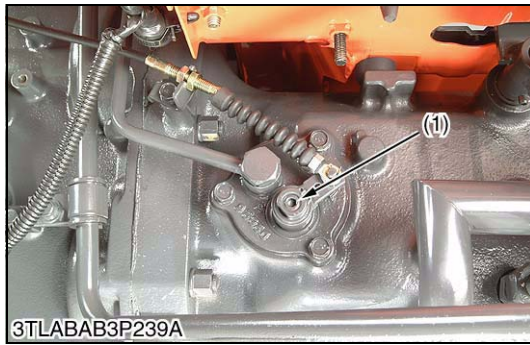

## (C) HST Linkages

### Operating Pressure of PTO Clutch Valve

1. Start the engine and warm up the transmission fluid, and then stop the engine.
2. Remove the plug (1) (PT 1/8) on the PTO valve spool (2).
3. Set the pressure gauge.
4. Start the engine and measure the pressure.
5. For adjustment use the adjusting shim (4) of HST charge relief valve (3).

#### ■ IMPORTANT

- Do not connect the universal joint of the implement to the tractor PTO shaft while testing.

Independent PTO pressure	When PTO shift lever is "ENGAGED" position	2.21 to 2.40 MPa 22.5 to 24.5 kgf/cm <sup>2</sup> 320 to 348 psi
	When PTO shift lever is "DISENGAGED" position	No pressure

#### Condition

- Engine speed ..... Idling speed
- Oil temperature ..... 40 to 60 °C  
104 to 140 °F

#### (Reference)

- Thickness of adjusting shim : 0.5 mm (0.02 in.)
- Pressure change per 0.5 mm (0.02 in.) of shim :  
Approx. 61.8 kPa  
0.68 kgf/cm<sup>2</sup>  
8.97 psi

- (1) Plug (PT 1/8)  
(2) Spool

- (3) Charge Relief Valve  
(4) Adjusting Shim

W1224108

### Checking Neutral

1. Disengage the front wheel drive lever. (Drive only rear wheels.)
2. Lift the rear of the tractor so that the rear wheels are off the ground and run the engine at low idling and drive only rear wheels.
3. Depress the one end of speed control pedal and release, and do the same at the other end.
4. If the rear wheels do not stop turning, adjust as following procedure of next page.

W1011525



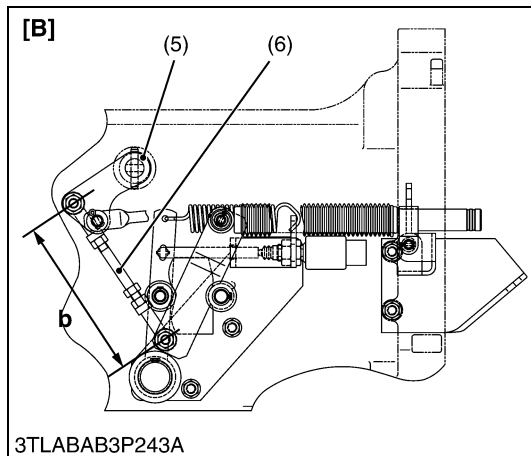
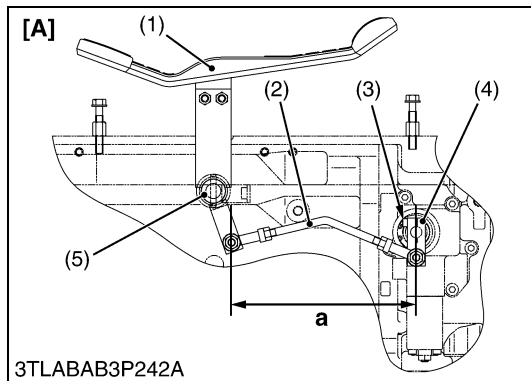

**Adjusting Neutral**

■ **NOTE**

- **Stop the engine when adjusting the HST neutral.**

1. Set the cruise control lever to “OFF” position. (HST pedal is in **Neutral** position.)
2. Check to see that the length **a** of HST control rod (2) and the length **b** of neutral rod (6) are specified length.  
If not, adjust as follows.  
Length **a** : 196.5 to 197.5 mm (7.74 to 7.78 in.)  
Length **b** : 139.5 to 140.5 mm (5.49 to 5.53 in.)
3. Loosen the hex. head screw (3) to make situation that HST control lever (4) moves freely. Run the engine for 5 seconds to make sure that the HST is in neutral position.
4. Tighten the hex. head screw (3) so that the HST control lever (4) does not turn.

■ **NOTE**

- **Be sure to tighten the hex. head screw with specified torque.**

Tightening torque	HST control lever setting hex. head screw	6.86 to 8.33 N·m 0.70 to 0.85 kgf·m 5.06 to 6.15 ft·lbs
-------------------	--	---

- (1) HST Pedal
- (2) HST Control Rod
- (3) Hex. Head Screw
- (4) HST Control Lever
- (5) Connecting Shaft
- (6) Neutral Rod

- [A] Right Side View
- [B] Left Side View
- a : Length of HST Control Rod
- b : Length of Neutral Rod

W1011601

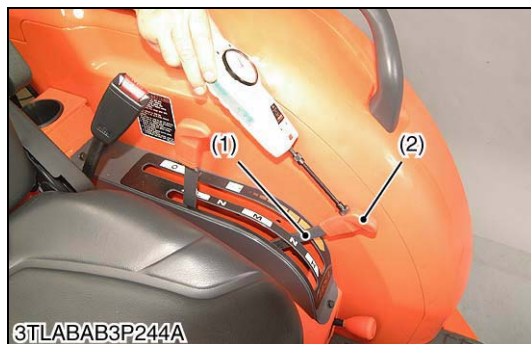

**Cruise Lever Operating Force**

1. Push the cruise control lever (1) into maximum tied position. After that pull it 50 mm (2 in.) back.
2. Measure the force needed to move the cruise control lever back into the maximum position at the top of the lever grip (2).
3. If the force is not within the factory specifications, loosen the lock nut (4) and adjust the tension of cruise spring (3).
4. Retighten the lock nut securely.

Cruise control lever operating force	Factory spec.	54 to 64 N 5.5 to 6.5 kgf 12.1 to 14.3 lbs
--------------------------------------	---------------	--

- (1) Cruise Control Lever
- (2) Lever Grip
- (3) Cruise Spring
- (4) Lock Nut

W1063742

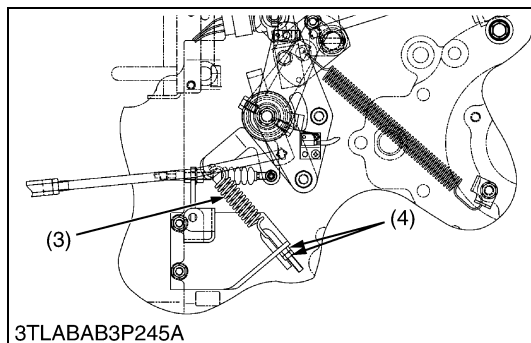



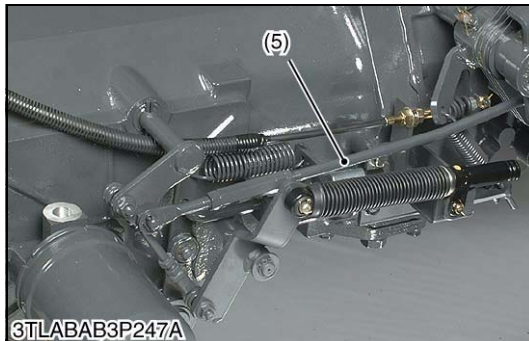
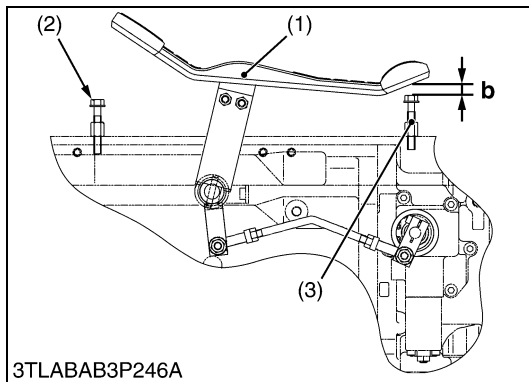
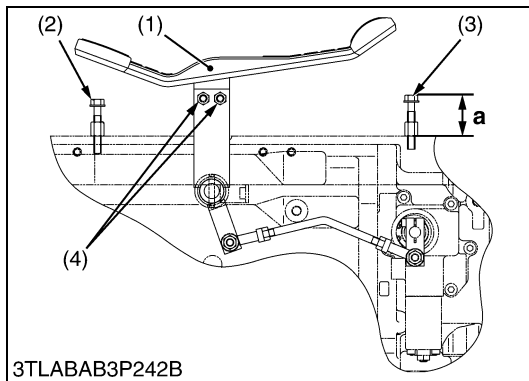

## Cruise Control Linkage and Maximum Travel Speed

### NOTE

- Stop the engine when adjusting the cruise control linkage and pedal stroke.
- Be sure to adjust the HST neutral position (see page 3-S90).
- Be sure to check whether the “traveling speed coefficient” is suitable for tire size. If not, input the appropriate code number. (Refer to page 9-S14.)

1. Loosen the HST pedal mounting screws (4) and tighten the screws (4) while pulling up the front of HST pedal (1).
2. Adjust the height **a** of the pedal stopper bolt F (3) to 35 to 40 mm (1.38 to 1.57 in.).
3. Run the tractor actually and confirm whether traveling speed is a factory specification. (See table below.)  
If not, adjust by height of stopper bolt F (3).

Traveling speed at rated engine speed	Factory spec.	28.6 km/h 17.8 mph

### Condition

- Engine Speed : Rated speed
  - Range Gear Shift Lever : **H** position
  - HST Pedal : Fully depressed forward
4. Set the cruise control lever to fully forward (Maximum position). HST pedal also tilts.
  5. Measure the clearance **b** of between bottom of HST pedal and tip of pedal stopper bolt F (3).

Length <b>b</b> of between HST pedal and stopper bolt F	Factory spec.	3 to 7 mm 0.12 to 0.28 in.

6. If the measurement is not within factory specification, adjust by the cruise adjusting rod (5). (Cruise Linkage Adjustment)
7. Shorten the pedal stopper bolt R (2) to the position where the length of the bolt is not touched to the HST pedal (1) even if the HST pedal is fully depressed rearward.
8. Lengthen the length of the pedal stopper bolt R (2) gradually with the HST pedal fully depressed rearward and lengthen the three turn from the position where the head of the stopper bolt touches the HST pedal further.

- |                          |                              |
|--------------------------|------------------------------|
| (1) HST Pedal            | (4) HST Pedal Mounting Screw |
| (2) Pedal Stopper Bolt R | (5) Cruise Adjusting Rod     |
| (3) Pedal Stopper Bolt F |                              |

W1230914

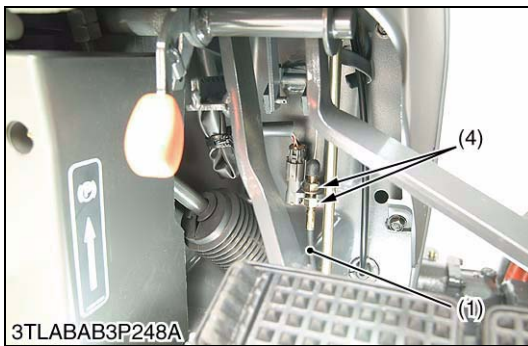
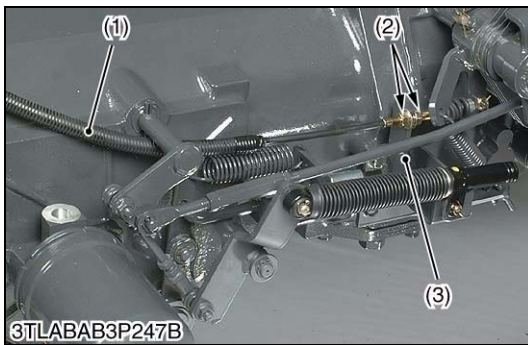

**Adjusting Cruise Control Release Linkage**

1. Adjust the brake pedals play first.
2. Depress one of the brake pedals to make sure the cruise control is not released. Also depress both the brake pedals coupled together to make sure that the cruise control is released.
3. If the cruise control does not work as above adjust with release wire (1) as follows.
  - Check to see that the threaded portion of the wire (1) rear side is set at the end position. If not, set by lock nuts (2).
  - Adjust by lock nuts (4) for the center of the threaded portion of the release wire front side to come to the hook position.
  - Confirm whether to move as above-mentioned 2.
  - If not, adjust by lock nut (4).

- (1) Release Wire (3) Damper Stay  
 (2) Lock Nut (Rear) (4) Lock Nut (Front)

W1013375

**(2) Disassembling and Assembling**

**(A) Separating Clutch Housing and Engine**

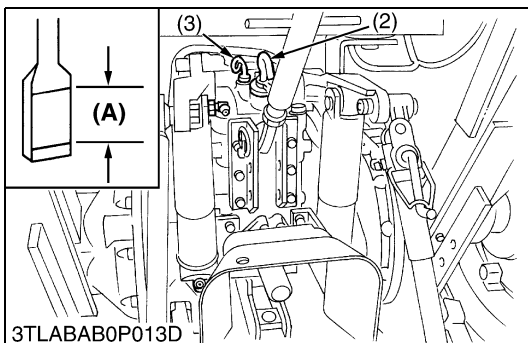
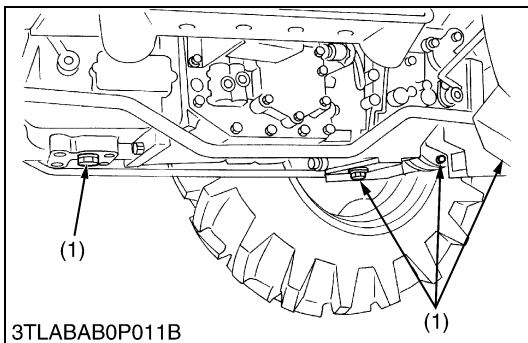

**Draining the Transmission Fluid**

1. Place oil pans underneath the transmission case.
2. Remove the drain plugs (1).
3. Drain the transmission fluid.
4. Reinstall the drain plugs (1).

**(When refilling)**

- Fill up from filling port after removing the filling plug (2) until reaching the upper notch on the dipstick (3).
- After running the engine for few minutes, stop it and check the oil level again, add the fluid to prescribed level if it is not correct level.

Transmission fluid	Capacity	45 L 11.9 U.S.gals 9.9 Imp.gals
--------------------	----------	---------------------------------------

**■ IMPORTANT**

- Use only KUBOTA SUPER UDT fluid. Use of other oils may damage the transmission or hydraulic system. Refer to “LUBRICANTS, FUEL AND COOLANT”. (See page G-7, 8.)
- Do not mix different brands of fluid together.

- (1) Drain Plugs (A) Oil level is acceptable within this range.  
 (2) Filling Plug  
 (3) Dipstick

W1242305



### Battery, Front Grill, Skirt and Bonnet

1. Open the bonnet and disconnect the battery negative cable.
2. Disconnect the head light connector and remove the front grill (4).
3. Remove the left and right side skirts (3).
4. Disconnect window washer hoses (2).
5. Remove the bonnet (1).

#### ■ NOTE

- **When disconnecting the battery cords, disconnect the negative cord first, when connecting, positive cord first.**

- |                        |                 |
|------------------------|-----------------|
| (1) Bonnet             | (3) Skirt       |
| (2) Window Washer Hose | (4) Front Grill |

W1242861

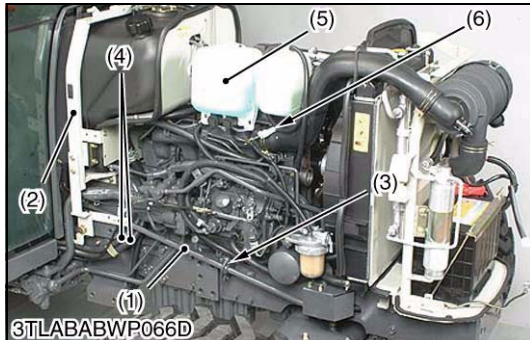

### Steering Joint, Brake Pedal Rod and Electric Wiring

1. Remove the tank frame support (2).
2. Remove the universal joint bolt (10) and steering joint support (3), and then remove the steering joint (1).
3. Disconnect the hand accelerator wire (7).
4. Disconnect the wiring connectors for engine stop solenoid (8), engine tachometer sensor (9) and glow plug.
5. Disconnect the heater hoses (4), and then reconnect their hoses to make loop.

#### ■ NOTE

- **Put a mark to the each heater hose before disconnecting.**
6. Disconnect the wiring connector for window washer tank (5) and compressor 1P connector (6).
  7. Disconnect the brake pedal rod.

#### (When reassembling)

- When accelerator wire is installed, adjust the wiring length as hit both the idling speed adjusting bolt and the maximum speed adjusting bolt by lever within the stroke of the accelerator lever.
- Set the steering joint (1) by the joint support (3) so that the steering wheel is turned lightly.
- Be sure to check and adjust the brake pedal free travel. (See page G-18.)

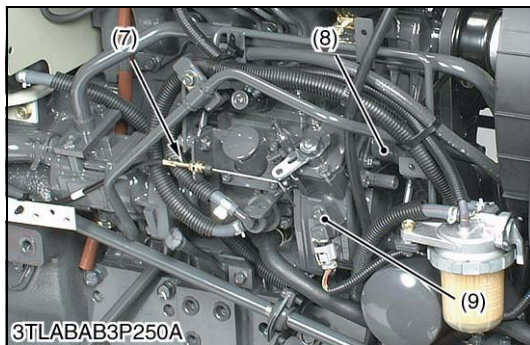

- |                            |                              |
|----------------------------|------------------------------|
| (1) Steering Joint         | (6) 1P Connector             |
| (2) Tank Frame Support     | (7) Accelerator Wire         |
| (3) Steering Joint Support | (8) Engine Stop Solenoid     |
| (4) Heater Hose            | (9) Engine Tachometer Sensor |
| (5) Window Washer Tank     | (10) Universal Joint Bolt    |

W1065071

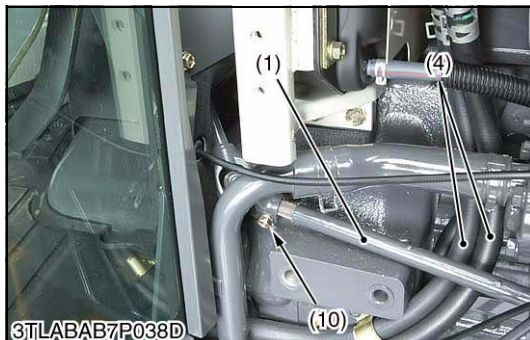



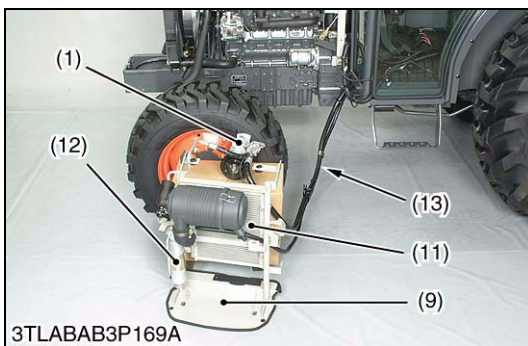
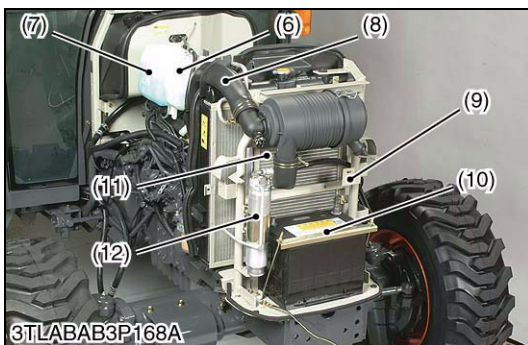
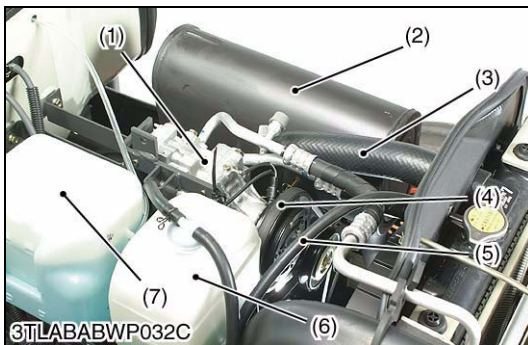
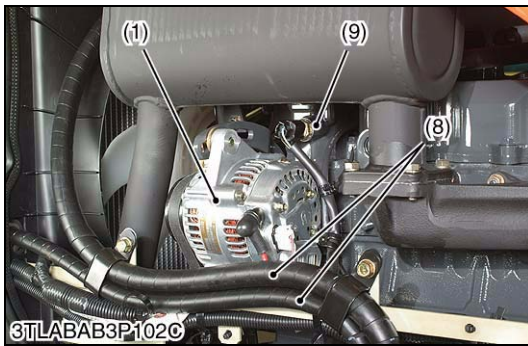
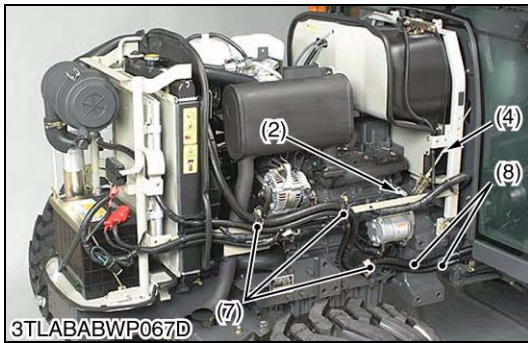

**Clutch Rod, Brake Pedal Rod and Electric Wiring**

1. Disconnect the brake pedal rod (5) and clutch rod (4).
2. Disconnect the wiring connectors for alternator (1), coolant temperature sensor (9), oil pressure switch (2), fuel unit (3), starter motor (6) and battery.
3. Remove the clamps and ground earth of wiring harness and collect wiring harness to the step or cabin.
4. Remove the clamps (7) of A/C hoses (8). (A/C model only.)

**(When reassembling)**

- Be sure to check and adjust the clutch and brake pedal free travel. (See page G-18, 24.)

- |                         |                                |
|-------------------------|--------------------------------|
| (1) Alternator          | (6) Starter Motor              |
| (2) Oil Pressure Switch | (7) Clamps                     |
| (3) Fuel Unit           | (8) A/C Hoses                  |
| (4) Clutch Rod          | (9) Coolant Temperature Sensor |
| (5) Brake Pedal Rod     |                                |

W1065311

**Air Conditioner Parts**

1. Remove the muffler (2).
2. Remove the air conditioner belt (4) and remove the compressor (1) mounting screw.
3. Remove the recovery tank (6) and window washer tank (7).
4. Disconnect the air cleaner hose (8).
5. Disconnect the recovery tank hose (5).
6. Disconnect the radiator upper hose (3).
7. Remove the oil cooler mounting screw.
8. Remove the battery (10).
9. Remove the battery stay mounting bolt.
10. Take out the compressor (1), condenser (11), receiver (12), hoses (13), battery stay (9) and etc. as a unit.

**(When reassembling)**

- After reassembling the compressor, be sure to adjust the air conditioner belt tension. (See page G-29.)

Tightening torque	Compressor mounting screw	24.5 to 29.4 N·m 2.5 to 3.0 kgf·m 18.1 to 21.7 ft·lbs
	Muffler mounting screw	31.4 to 37.2 N·m 3.2 to 3.8 kgf·m 23.1 to 27.5 ft·lbs

- |                          |                           |
|--------------------------|---------------------------|
| (1) Compressor           | (8) Air Cleaner Hose      |
| (2) Muffler              | (9) Battery Stay          |
| (3) Radiator Upper Hose  | (10) Battery              |
| (4) Air Conditioner Belt | (11) Condenser            |
| (5) Recovery Tank Hose   | (12) Receiver             |
| (6) Recovery Tank        | (13) Air Conditioner Hose |
| (7) Window Washer Tank   |                           |

W1248025

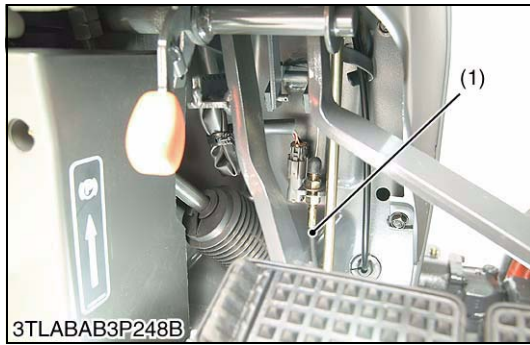

### Cruise Control Release Wire

1. Disconnect the cruise control release wire (1).

#### **(When reassembling)**

- Be sure to adjust the cruise control release wire (1). (See page 3-S92.)

(1) Cruise Control Release Wire

W1065983



### Seat, Seat Bracket and Lever Grips

1. Remove the seat.
2. Disconnect the seat switch connector (3) and remove the seat bracket (1) with seat suspension (7).
3. Remove the lever grips for position control lever (2), front wheel drive lever (6), range gear shift lever (5) and cruise control lever (4).

(1) Seat Bracket

(2) Position Control Lever

(3) Seat Switch Connector

(4) Cruise Control Lever

(5) Range Gear Shift Lever

(6) Front Wheel Drive Lever

(7) Seat Suspension

W1066109

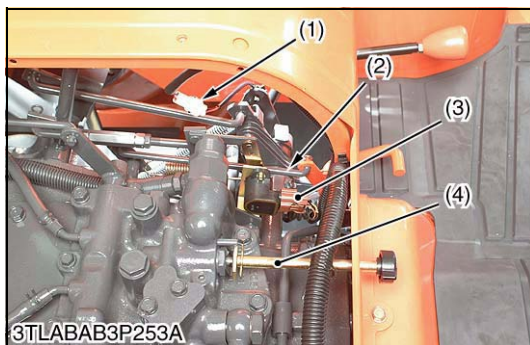

### Electric Connector for HST

1. Remove the lowering speed adjusting knob (4).
2. Disconnect the differential lock rod (2).
3. Disconnect the range gear shift lever sensor connector (3).
4. Disconnect the cruise switch connector (1).
5. Disconnect the HST pedal neutral switch connector (5).
6. Disconnect the ground earth **(a)**.

(1) Cruise Switch Connector

(2) Differential Lock Pedal

(3) Range Gear Shift Lever Sensor Connector

(a) Ground earth is connected here

(4) Lowering Speed Adjusting Knob

(5) HST Pedal Neutral Switch Connector

**(a) Ground earth is connected here**

W1066282

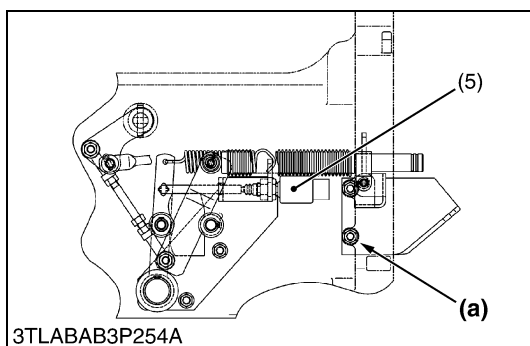

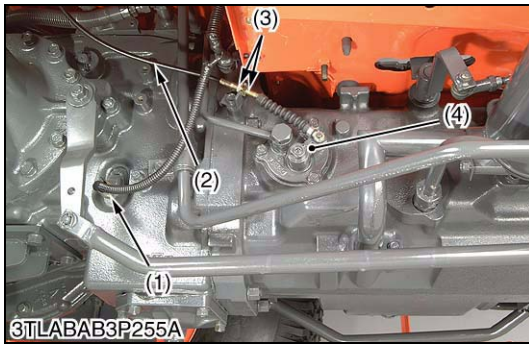

### PTO Shift Wire and Electric Connector

1. Disconnect the PTO shift wire (2) at the PTO clutch valve lever (4).
2. Disconnect the traveling speed sensor connector (1).

#### (When reassembling)

- When connecting the PTO shift wire (2) to the lever (4), be sure to adjust the length of wire as follows.
  1. Set the PTO shift lever to **OFF (Neutral)** position.
  2. Loosen the lock nut (3) of wire, and connect wire to the clutch valve lever (4), and then place the wire to the hook.
  3. Tighten the lock nut (3) clockwise (pull the wire), and lock the nut just before the lever moves.

- (1) Traveling Speed Sensor Connector      (3) Lock Nut  
 (2) PTO Shift Wire                              (4) PTO Clutch Valve Lever

W1066431



### Cabin Assembly

1. Remove the outer roof of cabin.
2. Support the cabin with nylon straps (1) and hoists.
3. Loosen and remove the cabin mounting bolts (2) and nuts (9).
4. Dismounting the cabin from tractor body.

#### ■ NOTE

- **Lift the cabin while making sure it does not catch on anything.**

#### (When reassembling)

- Be sure to install the washers and mount rubbers, etc. in their original positions.

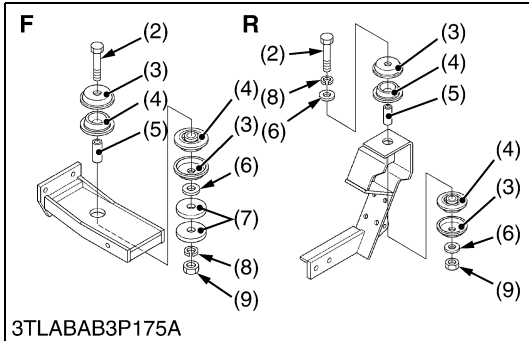

Tightening torque	Cabin mounting bolt and nut	124 to 147 N·m 12.6 to 15.0 kgf·m 91.1 to 108 ft·lbs
-------------------	-----------------------------	--

- (1) Nylon Straps                                      (7) Washer  
 (2) Bolt    (8) Spring Washer  
 (3) Plate    (9) Nut  
 (4) Mount Rubber  
 (5) Collar  
 (6) Plain Washer (M14)
- F : Front Side**  
**R : Rear Side**

W1252841



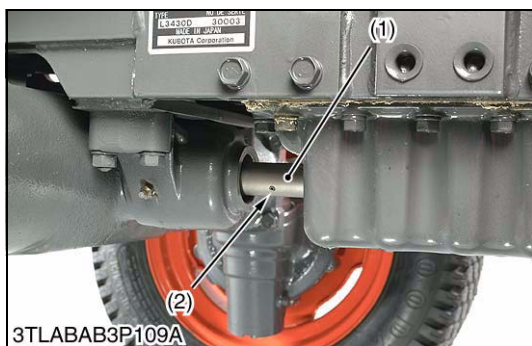
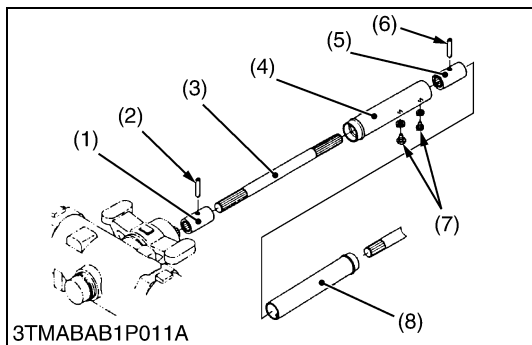
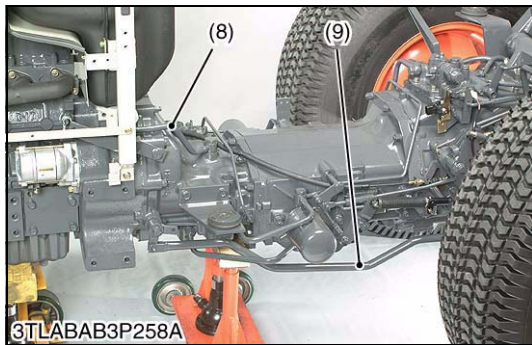
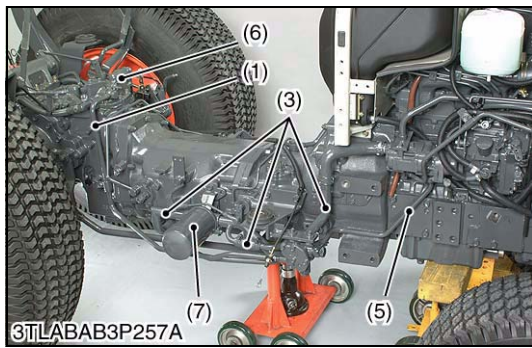
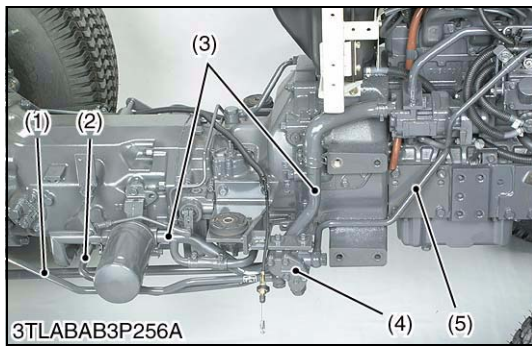

**Hydraulic Pipes**

1. Remove the main delivery pipe 1 (5).
2. Disconnect the main delivery pipe 2 (1) at the rear hydraulic block (6) and return pipe (2) at the mid case, and then remove the front hydraulic block (4) with pipes and bracket as a unit.
3. Remove the suction pipe (3) with oil filter (7).
4. Disconnect the oil cooler pipe (8) at the clutch housing.
5. Remove the brake rods (9).

**(When reassembling)**

Tightening torque	Joint bolt for main delivery pipe 1 to front hydraulic block	49 to 69 N·m 5.0 to 7.0 kgf·m 36.1 to 50.6 ft-lbs
	Joint bolt for main delivery pipe 2 to rear hydraulic block	49 to 69 N·m 5.0 to 7.0 kgf·m 36.1 to 50.6 ft-lbs
	Cap nut for return pipe to mid case	49 to 69 N·m 5.0 to 7.0 kgf·m 36.1 to 50.6 ft-lbs
	Joint bolt for oil cooler pipe	34 to 39 N·m 3.5 to 4.0 kgf·m 25.3 to 28.9 ft-lbs

- |                           |                          |
|---------------------------|--------------------------|
| (1) Main Delivery Pipe 2  | (6) Rear Hydraulic Block |
| (2) Return Pipe           | (7) Hydraulic Oil Filter |
| (3) Suction Pipe          | (8) Oil Cooler Pipe      |
| (4) Front Hydraulic Block | (9) Brake Rod            |
| (5) Main Delivery Pipe 1  |                          |

W1067018

**Propeller Shaft**

1. Slide the propeller shaft cover (4) and (8) after removing the screws (7).
2. Tap out the spring pins (2), (6) and slide the couplings (1), (5) and then remove the propeller shaft with covers (4), (8).

**(When reassembling)**

- Apply grease to the splines of propeller shaft 1 (3).
- |                           |                           |
|---------------------------|---------------------------|
| (1) Coupling              | (5) Coupling              |
| (2) Spring Pin            | (6) Spring Pin            |
| (3) Propeller Shaft 1     | (7) Screws                |
| (4) Propeller Shaft Cover | (8) Propeller Shaft Cover |

W1254425



3TLABAB3P259A

### Separating Engine and Clutch Housing

1. Place the disassembling stand under the engine and clutch housing case.
2. Remove the fuel tank support mounting screws.
3. Remove the engine and clutch housing mounting screws and nuts.
4. Separate the engine and clutch housing while lifting up the tank frame.

#### (When reassembling)

- Apply grease to the spline of clutch shaft.
- Apply liquid gasket (Three Bond 1211 or equivalent) to joint face of the flywheel housing and clutch housing.

Tightening torque	Engine and clutch housing mounting screw and nut	77.5 to 90.2 N·m 7.9 to 9.2 kgf·m 57.1 to 66.5 ft·lbs
	Engine and clutch housing mounting stud bolt	39.2 to 49.0 N·m 4.0 to 5.0 kgf·m 28.9 to 36.2 ft·lbs

W1067479

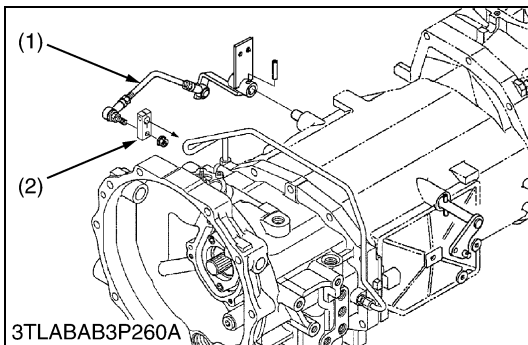

3TLABAB3P260A

### HST Linkage and Hydraulic Pipes

1. Disconnect the HST control rod (1) with the control lever (2).
2. Remove the charge delivery pipe 1 (3).
3. Remove the joint bolt (4) and disconnect the charge delivery pipe 2 (5) at the HST side.

#### (When reassembling)

- Be sure to adjust the HST neutral position. (See page 3-S90.)
- Install the copper washer securely.

Tightening torque	HST control lever setting hex. head screw	6.86 to 8.33 N·m 0.70 to 0.85 kgf·m 5.06 to 6.15 ft·lbs
	Joint bolt for charge delivery pipes to filter bracket	39 to 49 N·m 4.0 to 5.0 kgf·m 28.9 to 36.1 ft·lbs
	Cap nut for charge delivery pipe	49 to 59 N·m 5.0 to 6.0 kgf·m 36.1 to 43.4 ft·lbs

- |                            |                            |
|----------------------------|----------------------------|
| (1) HST Control Rod        | (4) Joint Bolt             |
| (2) HST Control Lever      | (5) Charge Delivery Pipe 2 |
| (3) Charge Delivery Pipe 1 |                            |

W1067625

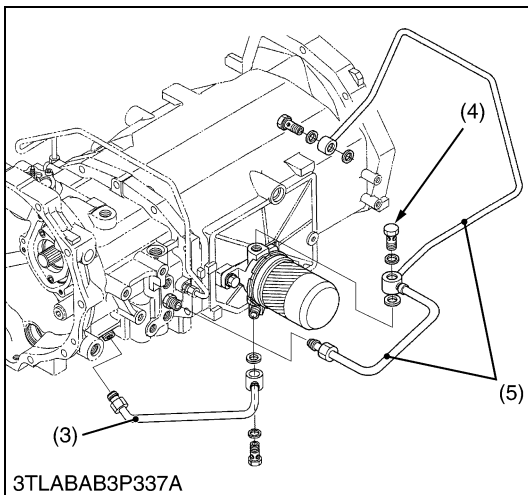

3TLABAB3P337A



### Separating Clutch Housing and Mid Case

1. Remove the clutch housing and mid case mounting screws and nuts.
2. Separate the clutch housing and mid case.

#### (When reassembling)

- Be sure to install the gasket.
- Apply liquid gasket (Three Bond 1208D or equivalent) to joint face of the clutch housing and mid case.

Tightening torque	Clutch housing and mid case mounting nut	102.9 to 117.6 N·m 10.5 to 12.0 kgf·m 75.9 to 86.8 ft-lbs
	Clutch housing and mid case mounting screw	77.5 to 90.2 N·m 7.9 to 9.2 kgf·m 57.1 to 66.5 ft-lbs
	Clutch housing and mid case mounting stud bolt	38.2 to 45.1 N·m 3.9 to 4.6 kgf·m 28.2 to 33.3 ft-lbs

W10679060

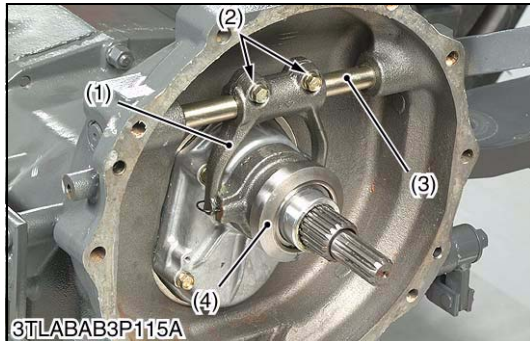

### Clutch Lever, Release Fork and Release Bearing

1. Remove the release fork mounting screws (2).
2. Draw out the clutch lever (3) to remove the release fork (1).
3. Remove the release bearing and release hub (4) together.

#### (When reassembling)

- Apply grease to the sliding surface of the clutch release hub.
- Apply grease to the clutch lever.

Tightening torque	Release fork mounting screw	23.5 to 27.5 N·m 2.4 to 2.8 kgf·m 17.4 to 20.3 ft-lbs
-------------------	-----------------------------	---

(1) Release Fork

(3) Clutch Lever

(2) Release Fork Mounting Screw

(4) Release Hub

W12561710

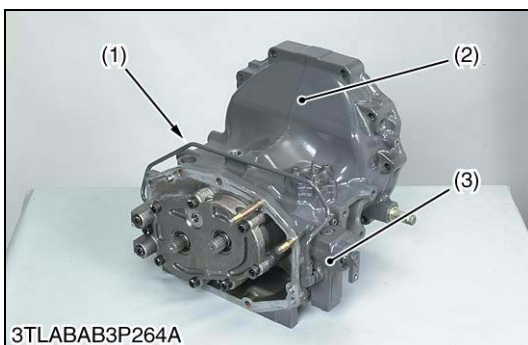
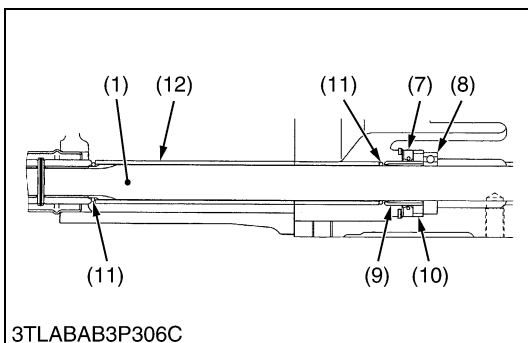
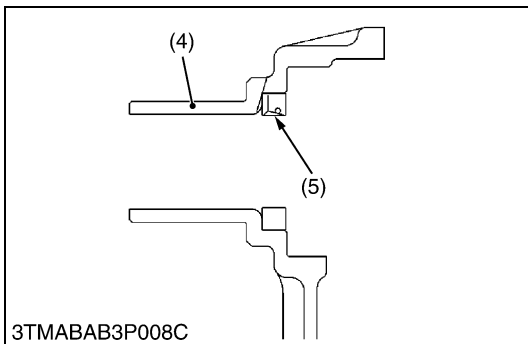
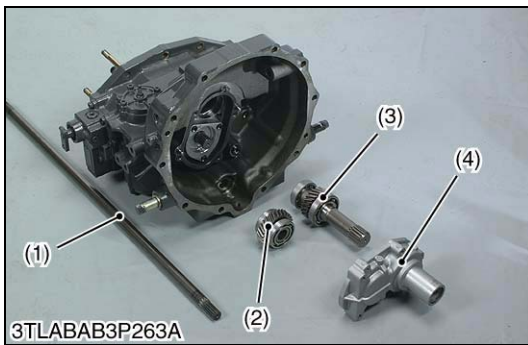

### Shaft Case, Input Shaft, Gear and Front Axle Drive Shaft

1. Remove the shaft case mounting screws.
2. Screw down the two M6 screws into the shaft case (4) and pull it out.
3. Take out the shaft case (4).
4. Take out the 24T gear shaft (3).
5. Take out the 26T gear (2).
6. Pull out the front axle drive shaft (1) to the rear side.

#### (When reassembling)

- Be sure to install the gasket.

#### (When replacing oil seal in shaft case)

- Install the oil seal (5) as shown in the figure, noting its direction.
- Apply grease to the oil seal (5).
- Install the front axle drive, shaft (1) from front side after assembling the clutch housing case (HST unit) and mid case. Then install the bearing (8), sleeve (9), collar (10), oil seal (7), internal snap ring (6), O-ring (11) and spacer (12) in order.

- |                            |             |
|----------------------------|-------------|
| (1) Front Axle Drive Shaft | (8) Bearing |
| (2) 26T Gear               | (9) Sleeve  |
| (3) 24T Gear Shaft         | (10) Collar |
| (4) Shaft Case             | (11) O-ring |
| (5) Oil Seal               | (12) Spacer |
| (6) Internal Snap Ring     |             |
| (7) Oil Seal               |             |

F : Front Side

W10682690

### HST Servo Pipe (Bypass Pipe)

1. Remove the servo pipe (1).

- |                               |                         |
|-------------------------------|-------------------------|
| (1) Servo Pipe                | (3) HST Servo Regulator |
| (2) HST Unit (Clutch Housing) |                         |

W1257288



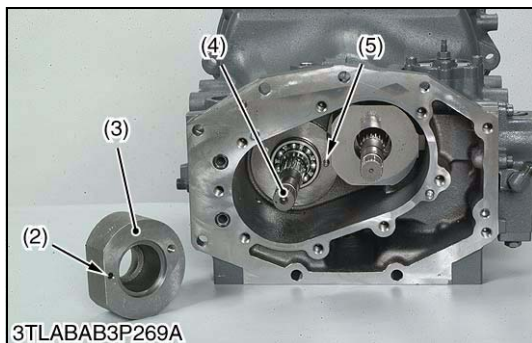
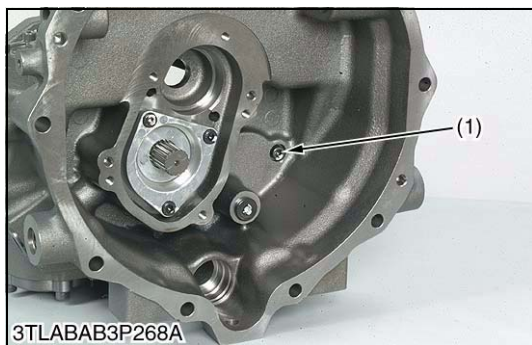
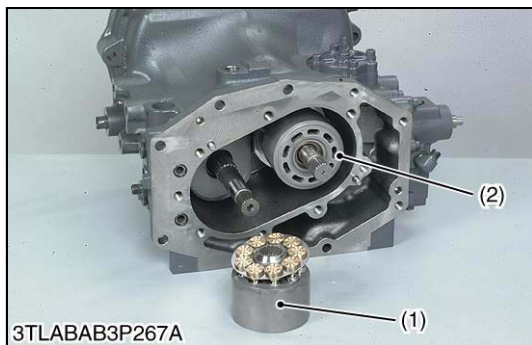
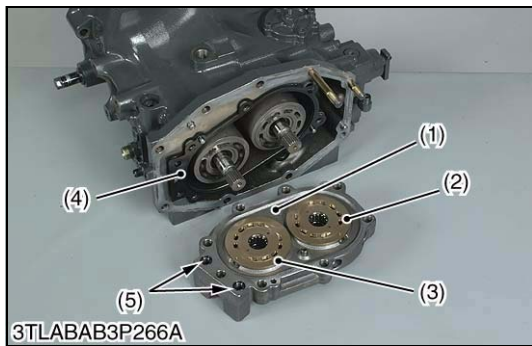
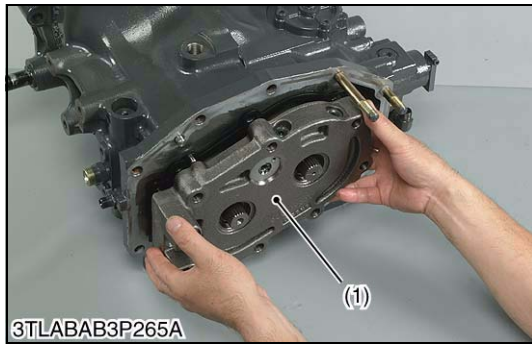

**Port Block**

1. Remove the port block mounting hex. head screws.
2. Pull and remove the port block (1) from the HST housing.

**(When reassembling)**

- Install port block with O-ring (5), valve plates and gasket in place.

**■ IMPORTANT**

- **Valve plates (2), (3) may stick to the port block but they are not fixed. Take care not to drop them.**

**And these valve plates are not interchangeable**

Tightening torque	Port block mounting hex. head screw	98 to 123 N·m 10.0 to 12.5 kgf·m 72.3 to 90.4 ft·lbs
-------------------	-------------------------------------	--

- |                          |            |
|--------------------------|------------|
| (1) Port Block           | (4) Gasket |
| (2) Valve Plate of Pump  | (5) O-ring |
| (3) Valve Plate of Motor |            |

W1018180

**Cylinder Block Assemblies**

1. Remove both motor and pump cylinders (1), (2) with pistons.

**(When reassembling)**

- Apply clean hydrostatic transmission oil to cylinder blocks.

**■ NOTE**

- **Take care not to damage the surface of cylinder blocks and pistons.**
- **Do not interchange pistons between pump and motor cylinder block.**

- |                          |                         |
|--------------------------|-------------------------|
| (1) Motor Cylinder Block | (2) Pump Cylinder Block |
|--------------------------|-------------------------|

W1018501

**Motor Shaft**

1. Remove the motor swashplate setting hex. head screw (1).
2. Remove the motor swashplate (3) and motor shaft (4).

**(When reassembling)**

- Be sure to install the thrust plate to swashplate (3).
- When installing the swashplate to clutch housing (HST body), be sure to align the hole (2) of swashplate and straight pin (5).
- Apply clean transmission oil to the thrust plate.

Tightening torque	Swashplate setting hex. head screw	28 to 35 N·m 2.9 to 3.6 kgf·m 21 to 26 ft·lbs
-------------------	------------------------------------	---

- |                      |                  |
|----------------------|------------------|
| (1) Hex. Head Screw  | (4) Motor Shaft  |
| (2) Hole             | (5) Straight Pin |
| (3) Motor Swashplate |                  |

W1069209

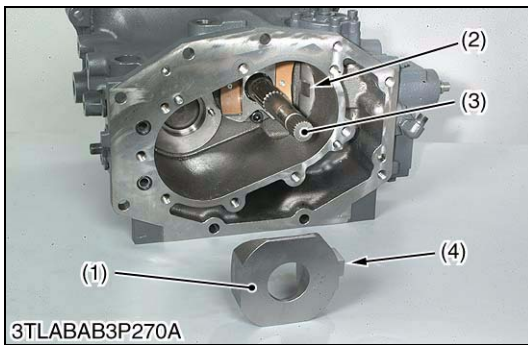

**Swashplate and Pump Shaft**

1. Remove the swashplate (1).
2. Remove the cradle bearing bracket mounting hex. head screws (6).
3. Tap the pump shaft (3) with a plastic hammer slightly to slide out it with cradle bearing bracket (5) to the rear side.

**(When reassembling)**

- Place the swashplate (1) into the housing, align the slot guide (4) of swashplate and groove (2) of servo piston.
- Apply clean transmission oil to the surface of swashplate and cradle bearing.

Tightening torque	Cradle bearing bracket mounting hex. head screw	28 to 35 N·m 2.9 to 3.6 kgf·m 21 to 26 ft-lbs
-------------------	---	---

- (1) Swashplate
- (2) Groove
- (3) Pump Shaft
- (4) Slot Guide
- (5) Cradle Bearing Bracket
- (6) Hex. Head Screw

W1018971

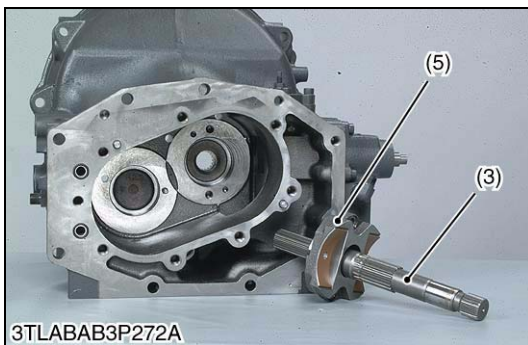
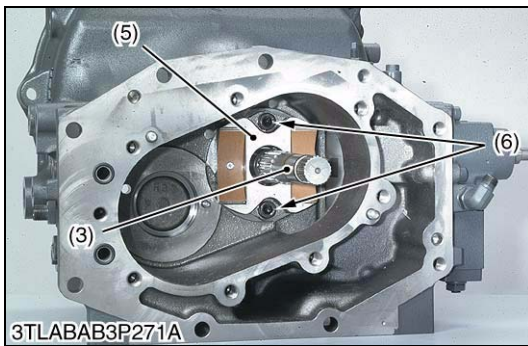

**Charge Pump**

1. Remove the charge pump mounting hex. head screws, and remove the charge pump cover (3).
2. Tap out the rotors (1), (2) with soft hummer slightly, and take out the rotors.

**(When reassembling)**

**■ NOTE**

- **Align the each alignment mark of rotors.**
- **Alignment mark should be rear side.**

Tightening torque	Charge pump case mounting screw	28 to 35 N·m 2.9 to 3.6 kgf·m 21 to 26 ft-lbs
-------------------	---------------------------------	---

- (1) Inner Rotor
- (2) Outer Rotor
- (3) Charge Pump Cover
- (4) Alignment Mark

W1017976

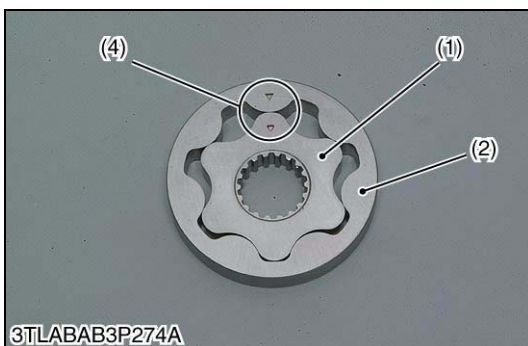
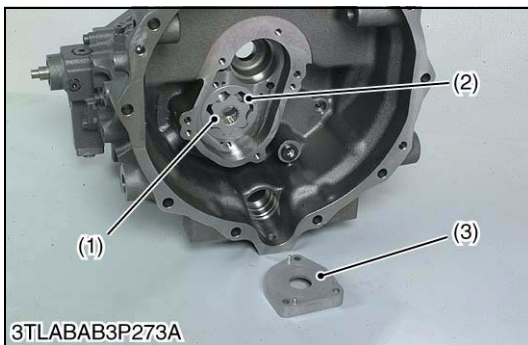



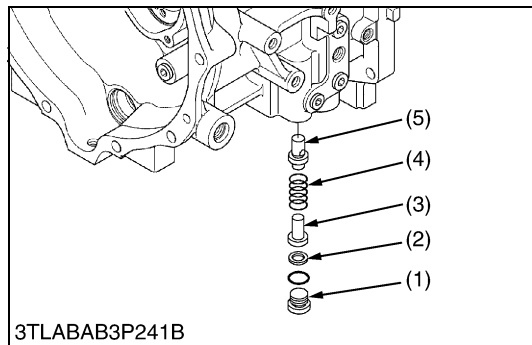

3TLABAB3P241B

### Charge Relief Valve

1. Remove the hex. head plug (1).
2. Remove the spring guide (3), shim (2), spring (4) and valve poppet (5).

#### (When reassembling)

#### ■ NOTE

- Install valve component, noting the number of shims (2) in the charge relief valve.
- Take care not to damage the O-ring.
- When replacing the valves, check and adjust the setting pressure. (Refer to page 3-S88.)

Tightening torque	Hex. head plug	30 to 37 N·m 3.1 to 3.8 kgf·m 22.4 to 27.5 ft·lbs
-------------------	----------------	---

- |                    |                  |
|--------------------|------------------|
| (1) Hex. Head Plug | (4) Spring       |
| (2) Shim           | (5) Valve Poppet |
| (3) Spring Guide   |                  |

W1019266

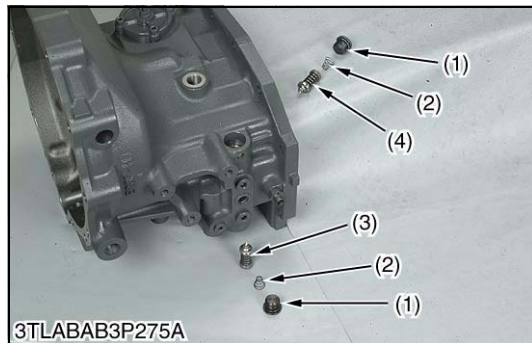

3TLABAB3P275A

### Check and High Pressure Relief Valve

1. Remove the hex. head plug (1) and remove the spring (2) and relief valve assembly (3), (4).

#### (When reassembling)

- Take care not to damage the O-ring on the plug.

Tightening torque	Hex. head plug	54 to 68 N·m 5.5 to 7.0 kgf·m 39.8 to 50.6 ft·lbs
-------------------	----------------	---

- |   |   |
|---|---|
| (1) Plug  | (4) Check and High Pressure Relief Valve Assembly (Reverse) |
| (2) Spring  |   |
| (3) Check and High Pressure Relief Valve Assembly (Forward) |   |

W1018316

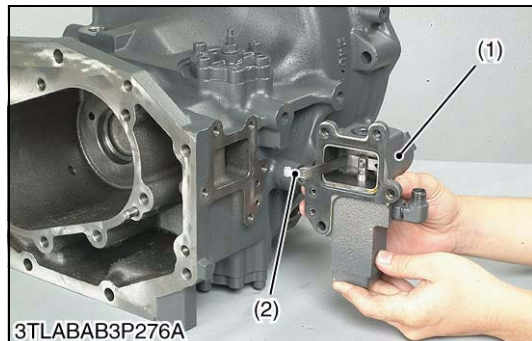

3TLABAB3P276A

### Servo Regulator Assembly

1. Remove the regulator mounting hex. head screw.
2. Remove the servo regulator assembly (1).

#### (When reassembling)

- Place a new gasket on the housing.
- Install the servo regulator assembly to the housing, align the feedback lever (2) of regulator and groove of servo piston.

#### ■ NOTE

- Do not disassemble the regulator assembly, since it has been factory-adjusted.

Tightening torque	Regulator mounting hex. head screw	6.9 to 8.3 N·m 0.7 to 0.85 kgf·m 5.1 to 6.1 ft·lbs
-------------------	------------------------------------	--

- |                              |                    |
|------------------------------|--------------------|
| (1) Servo Regulator Assembly | (2) Feedback Lever |
|------------------------------|--------------------|

W1019454



### Servo Piston Assembly

1. Remove the servo piston under cover (1).
2. Remove the servo piston assembly mounting hex. head screw.
3. Push the piston from bottom side slightly and pull out the servo piston assembly (2).

#### (When reassembling)

#### NOTE

- Take care not to do damage the surface of servo piston.
- Do not disassemble the servo piston assembly, since it has been factory-adjusted.

Tightening torque	Servo piston and cover mounting hex. head screw	28 to 35 N·m 2.9 to 3.6 kgf·m 21 to 26 ft·lbs
-------------------	---	---

(1) Servo Piston Under Cover

(2) Servo Piston Assembly

W1019685



### 1) Checking and Adjusting HST Neutral Position

#### CAUTION

- Park the tractor on a flat place and keep all the levers at neutral position.
- Jack up the engine tractor and bring it in the 2WD mode.

1. Fit the HST mechanism first and then exterior components until the engine can get started.
2. Remove the hex. socket head plug from F and R ports.
3. Assemble adaptor **58** (07916-52391) and thread joint (07916-50341) with the gasket between them.
4. Install the assembled adaptor **58** and thread joint F and R ports.
5. Measure the low and high HST charge pressures. Place 5 MPa (50 kgf/cm<sup>2</sup>, 725 psi) gauges on the two spots in the photo.
6. Lift the entire steps, as shown below, so that the piston can be adjusted.
7. If any of the servo piston parts has been replaced, readjust the HST neutral position, referring to the dimension **A** of the servo piston adjusting screw (1).
8. Start the engine and measure the low and high charge pressures. Now adjust the piston neutral position so that the low-side pressure and the high-side one be the same. (Take the measurement with the engine rpm at MAX.) Move the servo valve lever (2) and watch the tires' movement to ensure the neutral positioning.
9. Finally lock the piston adjusting nut and fit the exterior components.

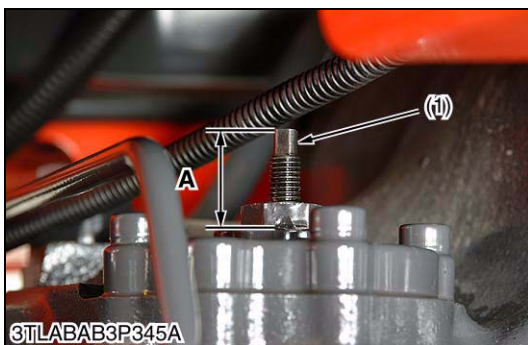

Charge pressure (Oil temperature 50 to 60 °C (122 to 140 °F))	Factory spec.	2.26 to 2.45 MPa 23 to 25 kgf/cm <sup>2</sup> 327 to 355 psi
---	---------------	--

#### (Reference)

- Dimension **A** : 26.3 mm (1.04 in.)

- (1) Adjusting Screw  
(2) Servo Valve Lever

**F** : Forward Side  
**R** : Reverse Side

W1299424



**(B) Mid Case**

■ **NOTE**

- For the disassembling procedure from “Draining the Transmission Fluid” to “Step and Floor Seat” or “Cabin Assembly”, refer to page 3-S92 to 3-S96.

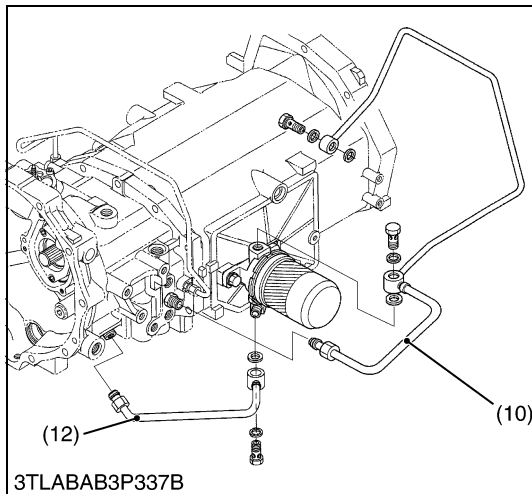
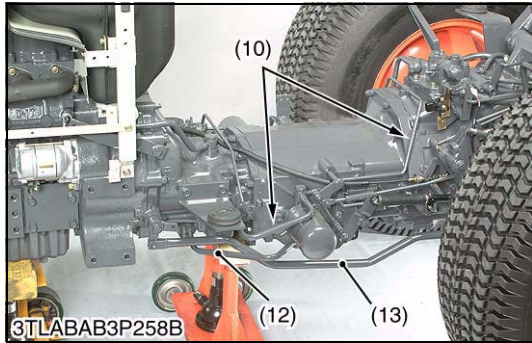
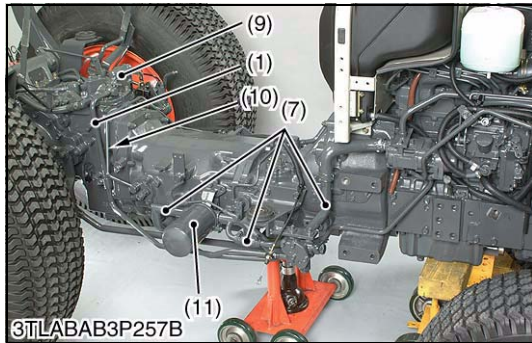
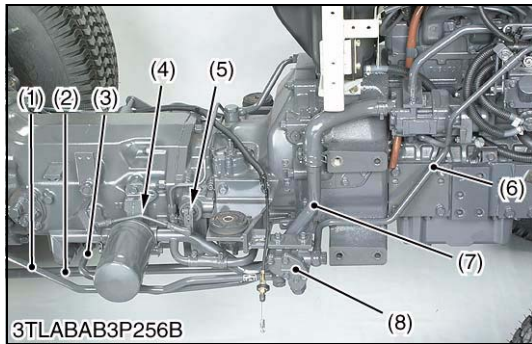

**Hydraulic Pipes**

1. Remove the HST control rod (4).
2. Remove the brake rods (2), (13).
3. Remove the main delivery pipe 1 (6).
4. Disconnect the main delivery pipe 2 (1) at the rear hydraulic block (9) and return pipe (3) at the mid case, and then remove the front hydraulic block (8) with pipes and bracket as a unit.
5. Remove the suction pipes (7) with oil filter (11).
6. Remove the charge delivery pipe 1 (12).
7. Remove the charge delivery pipe 2 (10).

**(When reassembling)**

- Install the copper washer securely.

Tightening torque	Joint bolt for main delivery pipe 1 to front hydraulic block	49 to 69 N·m 5.0 to 7.0 kgf·m 36.1 to 50.6 ft-lbs
	Joint bolt for main delivery pipe 2 to rear hydraulic block	49 to 69 N·m 5.0 to 7.0 kgf·m 36.1 to 50.6 ft-lbs
	Cap nut for return pipe to mid case	49 to 69 N·m 5.0 to 7.0 kgf·m 36.1 to 50.6 ft-lbs
	Joint bolt for charge delivery pipes to filter bracket	39 to 49 N·m 4.0 to 5.0 kgf·m 28.9 to 36.1 ft-lbs
	Joint bolt for charge delivery pipe 2 to PTO clutch valve	34 to 39 N·m 3.5 to 4.0 kgf·m 25.3 to 28.9 ft-lbs
	Cap nut for charge delivery pipes	49 to 59 N·m 5.0 to 6.0 kgf·m 36.1 to 43.4 ft-lbs

- |                          |                             |
|--------------------------|-----------------------------|
| (1) Main Delivery Pipe 2 | (8) Front Hydraulic Block   |
| (2) Brake Rod RH         | (9) Rear Hydraulic Block    |
| (3) Return Pipe          | (10) Charge Delivery Pipe 2 |
| (4) HST Control Rod      | (11) Oil Filter             |
| (5) HST Control Lever    | (12) Charge Delivery Pipe 1 |
| (6) Main Delivery Pipe 1 | (13) Brake Rod LH           |
| (7) Suction Pipe         |                             |

W1071129

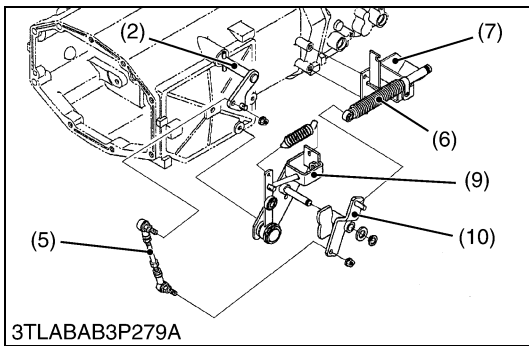
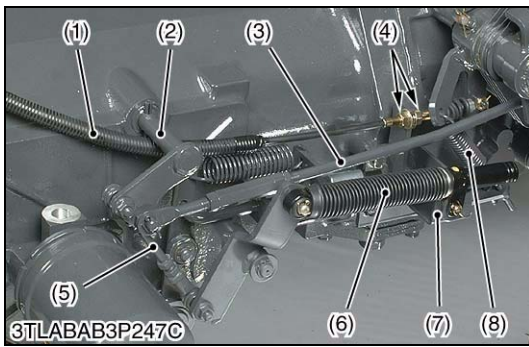

**HST Linkages**

1. Remove the cruise adjusting rod (3).
2. Disconnect the neutral rod (5) from connecting shaft (2).
3. Disconnect the damper (6) from neutral holder arm (9).
4. Remove the neutral rod (5), neutral holder (9) and neutral holder arm (10) as a unit.
5. Disconnect the cruise spring (8), and remove the damper stay (7) with damper (6).
6. Remove the cruise release wire (1).

**(When reassembling)**

- When installing the cruise wire (1) to the damper bracket (7) set the lock nuts (4) so that the threaded position of wire (1) becomes end.
- Be sure to check the cruise wire releasing. (See page 3-S92.)
- Be sure to adjust the HST neutral position. (See page 3-S90.)

- |                          |                         |
|--------------------------|-------------------------|
| (1) Cruise Release Wire  | (6) Damper              |
| (2) Connecting Shaft     | (7) Damper Stay         |
| (3) Cruise Adjusting Rod | (8) Cruise Spring       |
| (4) Lock Nut             | (9) Neutral Holder      |
| (5) Neutral Rod          | (10) Neutral Holder Arm |

W1260145



**Separating Mid Case and Transmission Case**

1. Separate the mid case and transmission case after removing their mounting screws.

**(When reassembling)**

- Confirm to insert the PTO shaft to PTO clutch firmly, turning the PTO shaft.
- Apply liquid gasket (Three Bond 1208D or equivalent) to joint face of the mid case and transmission case.

Tightening torque	Mid case and transmission case mounting screw	77.5 to 90.2 N·m 7.9 to 9.2 kgf·m 57.1 to 66.5 ft·lbs
	Mid case and transmission case mounting nut	102.9 to 117.6 N·m 10.5 to 12.0 kgf·m 75.9 to 86.8 ft·lbs
	Mid case and transmission case mounting stud bolt	39.2 to 49.0 N·m 4.0 to 5.0 kgf·m 28.9 to 36.2 ft·lbs

W1071622



**Separating Mid Case**

1. Separate the mid case from the clutch housing after removing their mounting screws.

**(When reassembling)**

- Apply liquid gasket (Three Bond 1208D or equivalent) to joint face of clutch housing and mid case.
- Be sure to install the gasket.

Tightening torque	Clutch housing and mid case mounting screw	77.5 to 90.2 N·m 7.9 to 9.2 kgf·m 57.1 to 66.5 ft·lbs
	Clutch housing and mid case mounting nut	102.9 to 117.6 N·m 10.5 to 12.0 kgf·m 75.9 to 86.8 ft·lbs
	Clutch housing and mid case mounting stud bolt	38.2 to 45.1 N·m 3.9 to 4.6 kgf·m 28.2 to 33.3 ft·lbs

W1071785

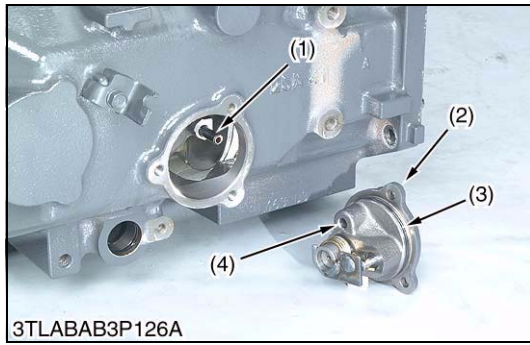

**PTO Clutch Valve**

1. Remove the PTO clutch valve (2) as a unit.
2. Pull out the pipe (1).

**(When reassembling)**

- Apply small amount of grease for the O-ring (3).
- Install the pipe (1) to the hole (4) of the PTO clutch valve (2) firmly.
- Replace the pipe (1) with new one.

Tightening torque	PTO clutch valve mounting screw	23.5 to 27.5 N·m 2.4 to 2.8 kgf·m 17.4 to 20.3 ft·lbs
-------------------	---------------------------------	---

- (1) Pipe
- (2) PTO Clutch Valve
- (3) O-ring
- (4) Hole

W1260974

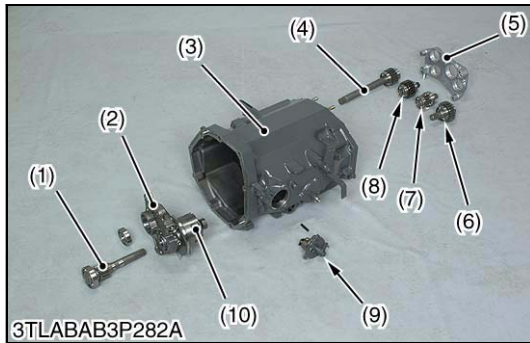

**Mid Case Bearing Holder with Gears**

1. Remove the mid case bearing holder 1 (5).
2. Take out the gear shafts (4), (8), (7), (6).
3. Remove the PTO drive shaft (1).
4. Remove the mid case bearing holder 2 (2) with PTO clutch (10).

**(When reassembling)**

- Tap in the mid case bearing holder (2), (5) with plastic hammer until contact to mid case, and then tighten the screws to specified torque.

Tightening torque	Mid case bearing holder mounting screw	48.1 to 55.9 N·m 4.9 to 5.7 kgf·m 35.4 to 41.2 ft·lbs
-------------------	--	---

- (1) PTO Drive Shaft
- (2) Mid Case Bearing Holder 2
- (3) Mid Case
- (4) 21T Gear Shaft
- (5) Mid Case Bearing Holder 1
- (6) 25T Gear Shaft
- (7) 15T Gear Shaft
- (8) 22T Gear Shaft
- (9) PTO Clutch Valve
- (10) PTO Clutch

W1072101

**Disassembling PTO Clutch**

1. See page 3-S32, S33.

W1294451

**(C) Transmission Case**

**NOTE**

- For the disassembling procedure from “Draining the Transmission Fluid” to “Step and Floor Seat” or “Cabin Assembly”, refer to page 3-S92 to 3-S96.



**Rear Wheel**

1. Place disassembling stand under the transmission case, and support it with a jack.
2. Remove the rear wheels.
3. After removing the rear wheels, support it at both sides of rear axle by stands.

**(When reassembling)**

Tightening torque	Rear wheel mounting screw and nut	215 N·m 22 kgf·m 160 ft·lbs
	Rear wheel mounting stud bolt	98.1 to 112.8 N·m 10.0 to 11.5 kgf·m 72.3 to 83.2 ft·lbs

W1261766



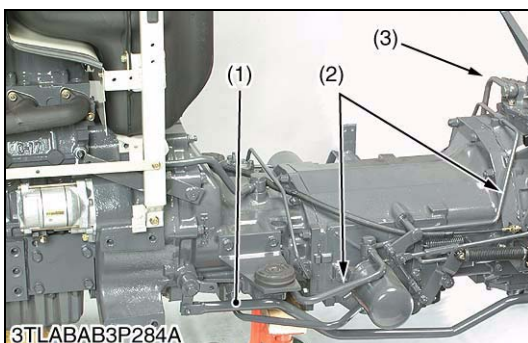
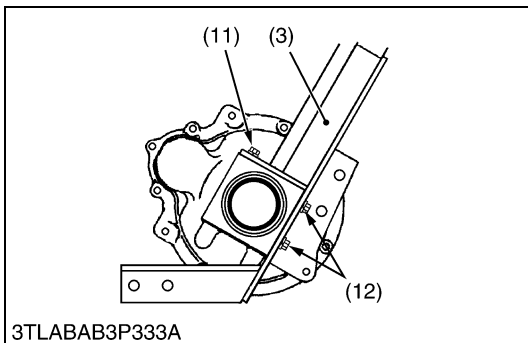
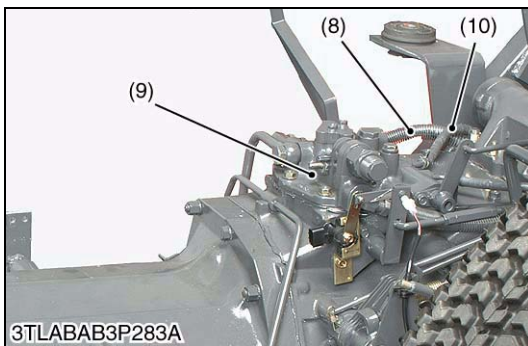
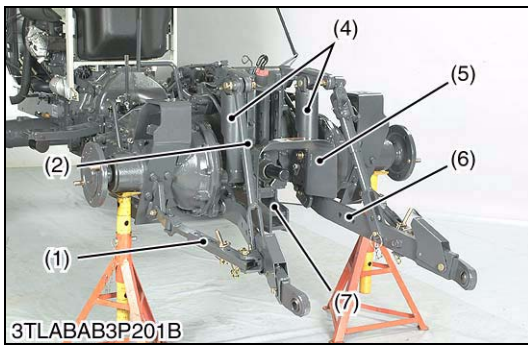

**ROPS, 3 Point Linkages, Hydraulic Cylinders and Others**

1. Remove the top link.
2. Remove the lift rods (2), lower links (5) and check chains (1) as a unit.
3. Remove the PTO shaft cover (4).
4. Remove the drawbar frame (6).
5. Disconnect the hydraulic cylinder hoses (7) and return hoses (9) at the rear hydraulic block (8).
6. Remove the two pins and remove the hydraulic cylinders (3).
7. Disconnect the brake rods.

**(When reassembling)**

- Apply grease to the lower link pins and hydraulic cylinder pins.

Tightening torque	Lift arm pin mounting nut	77.5 to 90.2 N-m 7.9 to 9.2 kgf-m 57.1 to 66.5 ft-lbs
	Lift arm pin lock nut	62.8 to 72.6 N-m 6.4 to 7.4 kgf-m 46.3 to 53.5 ft-lbs
	Drawbar frame mounting screw (M12)	77.5 to 90.2 N-m 7.9 to 9.2 kgf-m 57.1 to 66.5 ft-lbs
	Drawbar frame mounting screw (M14)	167 to 196 N-m 17.0 to 20.0 kgf-m 123 to 145 ft-lbs
	Hydraulic cylinder hose	34.3 to 48.1 N-m 3.5 to 4.9 kgf-m 25.3 to 35.4 ft-lbs

- |                        |                             |
|------------------------|-----------------------------|
| (1) Check Chain        | (7) Hydraulic Cylinder Hose |
| (2) Lift Rod           | (8) Rear Hydraulic Block    |
| (3) Hydraulic Cylinder | (9) Return Hose             |
| (4) PTO Shaft Cover    | (10) Screw (M14 × 155)      |
| (5) Lower Link         | (11) Screw (M14 × 30)       |
| (6) Drawbar Frame      |                             |

W1261978

**Hydraulic Pipes**

1. Remove the brake rods (1).
2. Remove the charge delivery pipe 2 (2).
3. Remove the joint bolt (3) for main delivery pipe 2.

**(When reassembling)**

- Install the copper washer securely.

Tightening torque	Joint bolt for main delivery pipe 2 to rear hydraulic block	49 to 69 N-m 5.0 to 7.0 kgf-m 36.1 to 50.6 ft-lbs
	Joint bolt for charge delivery pipe 2 to filter bracket	39 to 49 N-m 4.0 to 5.0 kgf-m 28.9 to 36.1 ft-lbs
	Joint bolt for charge delivery pipe 2 to PTO clutch valve	34 to 39 N-m 3.5 to 4.0 kgf-m 25.3 to 28.9 ft-lbs

- |                            |   |
|----------------------------|---|
| (1) Brake Rod              | (3) Joint Bolt for Main Delivery Pipe 2 |
| (2) Charge Delivery Pipe 2 |   |

W1073148



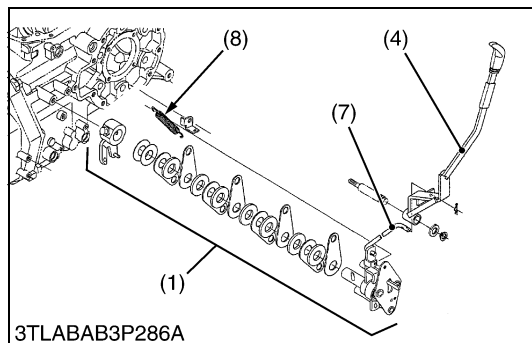
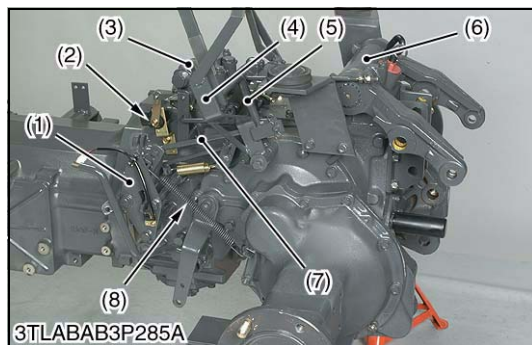
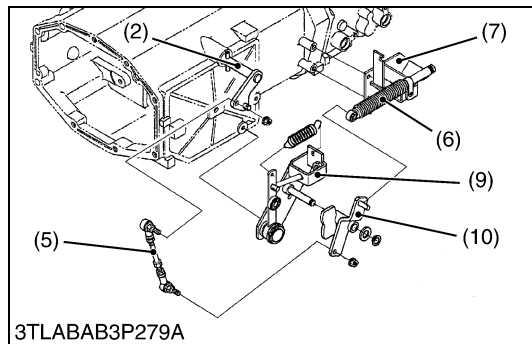
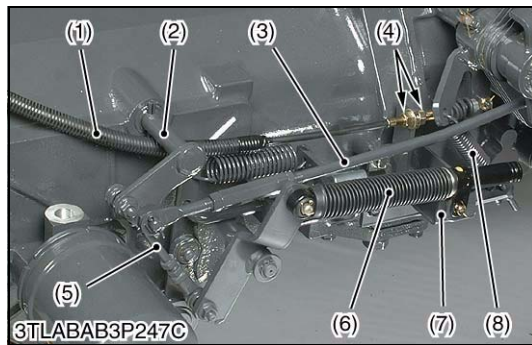

### HST Linkages

1. Remove the cruise adjusting rod (3).
2. Disconnect the neutral rod (5) from connecting shaft (2).
3. Disconnect the damper (6) from neutral holder arm (9).
4. Remove the neutral rod (5), neutral holder (9) and neutral holder arm (10) as a unit.
5. Disconnect the cruise spring (8), and remove the damper stay (7) with damper (6).
6. Remove the cruise release wire (1).

### (When reassembling)

- When installing the cruise wire (1) to the damper bracket (7) set the lock nuts (4) so that the threaded position of wire (1) becomes end.
- Be sure to check the cruise wire releasing. (See page 3-S92.)
- Be sure to adjust the HST neutral position. (See page 3-S90.)

(1) Cruise Release Wire	(6) Damper
(2) Connecting Shaft	(7) Damper Stay
(3) Cruise Adjusting Rod	(8) Cruise Spring
(4) Lock Nut	(9) Neutral Holder
(5) Neutral Rod	(10) Neutral Holder Arm

W1263843

### Cruise Linkage, Rear Hydraulic Block and Lift Arm Bracket

1. Remove the cruise lever rod (7) and release spring (8).
2. Remove the cruise assembly mounting screws (Three screws) and remove the cruise assembly (1).
3. Remove the range gear shift lever rod and remove the range gear shift lever sensor (2) with stay.
4. Remove the external snap ring and remove the range gear shift lever (5) and cruise control lever (4).
5. Remove the rear hydraulic block (3), cover and lift arm support (6) as a unit.

### (When reassembling)

- Apply liquid gasket (Three Bond 1208D or equivalent) to joint face of the differential case and cover.
- Be sure to check cruise lever operation force and cruise control linkage. (See page 3-S90.)

(1) Cruise Assembly	(5) Range Gear Shift Lever
(2) Range Gear Shift Lever Sensor	(6) Lift Arm Support
(3) Rear Hydraulic Block	(7) Cruise Lever Rod
(4) Cruise Control Lever	(8) Return Spring

W1264120



3TLABAB3P139A

### Rear Axle

1. Separate the rear axle case from brake case.

#### (When reassembling)

- Apply liquid gasket (Three Bond 1208D or equivalent) to joint face of the rear axle and brake case.

Tightening torque	Rear axle case mounting screw and nut	M10 screw and nut (7T)	48.1 to 55.9 N-m 4.9 to 5.7 kgf-m 35.4 to 41.2 ft-lbs
		Stud bolt	24.5 to 31.4 N-m 2.5 to 3.2 kgf-m 18.1 to 23.1 ft-lbs
		M10 nut (9T)	60.8 to 70.6 N-m 6.2 to 7.2 kgf-m 44.9 to 52.1 ft-lbs
		M12 screw	77.5 to 90.2 N-m 7.9 to 9.2 kgf-m 57.1 to 66.5 ft-lbs

W1266378



3TLABAB3P140A

### Brake Case

1. Remove the range gear shift lever and its fulcrum screw.
2. Remove the brake case mounting screws and nuts.
3. Separate the brake case, tapping the brake case lever lightly.

#### (When reassembling)

- Apply grease to the steel ball seats. (Do not grease excessively.)
- Apply liquid gasket (Three Bond 1208D or equivalent) to joint face of the brake case and transmission case.
- Be sure to apply liquid gasket to **A** position.
- Be sure to fix the brake cam and cam plate.
- Before installing the brake case to the transmission case, install the cam plate to the transmission case.

Tightening torque	Brake case mounting stud bolt	29.4 to 49.0 N-m 3.0 to 5.0 kgf-m 21.7 to 36.1 ft-lbs
	Brake case mounting screw and nut	77.5 to 90.2 N-m 7.9 to 9.2 kgf-m 57.1 to 66.5 ft-lbs
	Lever fulcrum screw	62.8 to 72.5 N-m 6.4 to 7.4 kgf-m 46.3 to 53.5 t-lbs

W12666170



**Separating Mid Case and Transmission Case**

1. Separate the mid case and transmission case after removing their mounting screws and nut.

**(When reassembling)**

- Confirm to insert the PTO shaft to PTO clutch firmly, turning the PTO shaft.
- Confirm to insert the front wheel drive shaft to coupling firmly.
- Apply liquid gasket (Three Bond 1208D or equivalent) to joint face of the mid case and transmission case.

Tightening torque	Mid case and transmission case mounting screw	77.5 to 90.2 N·m 7.9 to 9.2 kgf·m 57.1 to 66.5 ft-lbs
	Mid case and transmission case mounting nut	102.9 to 117.6 N·m 10.5 to 12.0 kgf·m 75.9 to 86.8 ft-lbs
	Mid case and transmission case mounting stud bolt	39.2 to 49.0 N·m 4.0 to 5.0 kgf·m 28.9 to 36.2 ft-lbs

W1073847

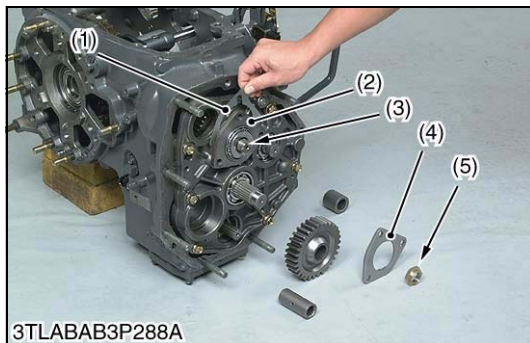

**Pinion Bearing Cover**

1. Remove the stake of lock nut (5).
2. Lock the turning of spiral bevel pinion and remove the lock nut (5).
3. Remove the pinion bearing case mounting screws.
4. Take out the pinion bearing cover (4) and shims (1).

**(When reassembling)**

- Make sure of the number of shims in the pinion bearing case.
- Replace the lock nut (5) with a new one, and stake the lock nut firmly after installing the parts on the shaft.

Tightening torque	Lock nut	147 to 196 N·m 15 to 20 kgf·m 108 to 145 ft-lbs
	Pinion bearing case mounting screw	39.2 to 44.1 N·m 4.0 to 4.5 kgf·m 28.9 to 32.5 ft-lbs

- (1) Shim
- (2) Pinion Bearing Case
- (3) Spiral Bevel Pinion Shaft
- (4) Pinion Bearing Cover
- (5) Lock Nut

W1267146

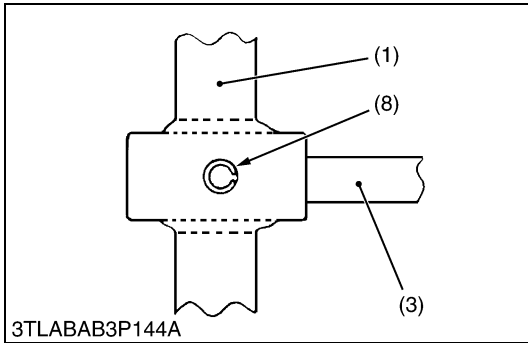
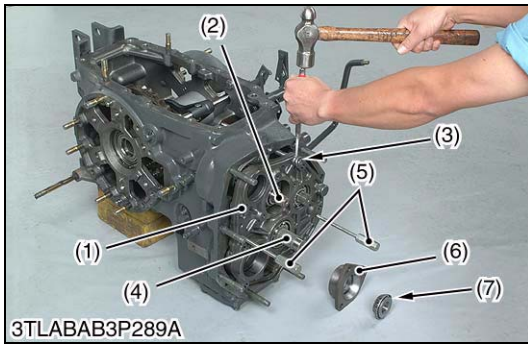

### Transmission Bearing Holder

1. Remove the transmission bearing holder mounting screws.
2. Tap out the spring pin (8) on the shift fork rod (3).
3. Jack up the bearing holder (1) by using the two jack screws (5) until the taper roller bearing (7) can be removed.

#### NOTE

- Jack up the bearing holder while hitting the two shafts (2) (4) by copper hammer or soft hammer.
4. Jack up more and remove the transmission bearing holder (1).
- (When reassembling)**
- Tap in the transmission bearing holder with soft hammer until contact to transmission case, and then tighten the screws to specified torque.
  - Tap in the spring pin (8) so that its split portion may face forward. (Refer to figure.)

Tightening torque	Transmission bearing holder mounting screw	48.1 to 55.9 N·m 4.9 to 5.7 kgf·m 35.5 to 41.2 ft-lbs
-------------------	--	---

- |   |                              |
|---|------------------------------|
| (1) Transmission Bearing Holder         | (6) Pinion Bearing Case      |
| (2) Spiral Bevel Pinion Shaft           | (7) Taper Roller Bearing     |
| (3) Shift Fork Rod for Range Gear Shift | (8) Spring Pin               |
| (4) PTO Drive Shaft                     | (9) Range Gear Shaft         |
| (5) Jack Screw                          | (10) Front Wheel Drive Shaft |

W1267434



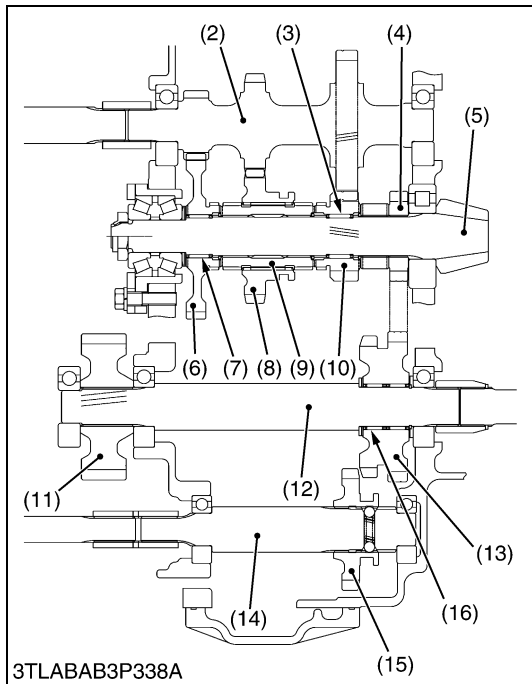
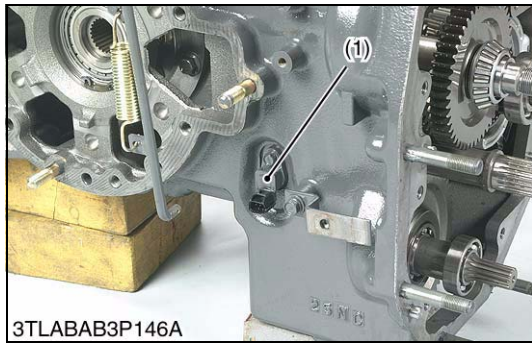

**Shaft Assemblies**

1. Remove the traveling speed sensor (1).
2. Take out the spiral bevel pinion shaft assembly (4) with shift fork (6), range gear shaft assembly (5) and PTO drive shaft assembly (3).
3. Take out the front wheel drive shaft (2).

**(When reassembling)**

- Apply transmission fluid to needle bearings (12).

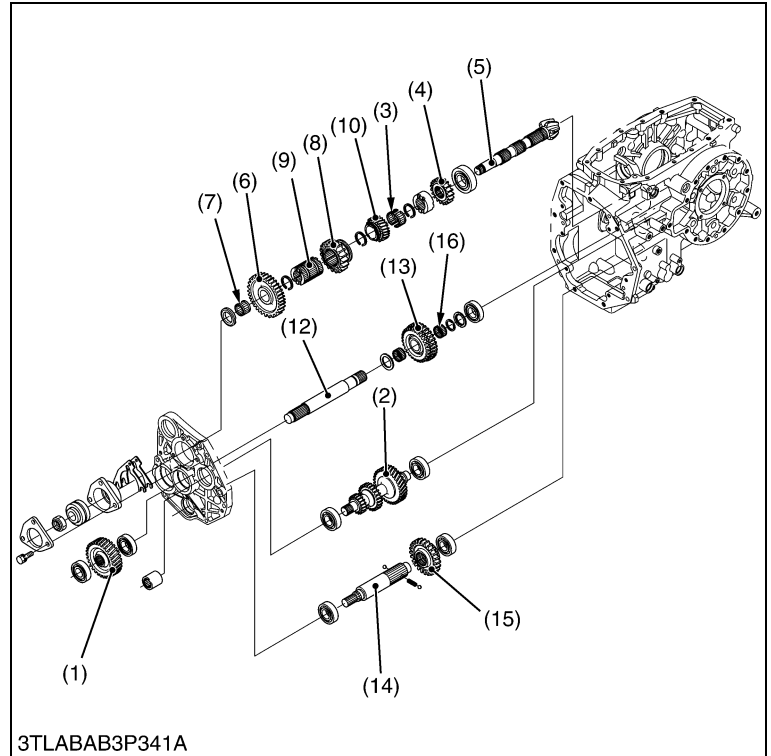

- |                               |                              |
|-------------------------------|------------------------------|
| (1) Traveling Speed Sensor    | (9) Spline Boss              |
| (2) 19T-24T-31T Gear Shaft    | (10) 17T Gear                |
| (3) Needle Bearing            | (11) 11T Gear                |
| (4) 17T Gear                  | (12) PTO Drive Shaft         |
| (5) Spiral Bevel Pinion Shaft | (13) 29T-32T Gear            |
| (6) 49T Gear                  | (14) Front Wheel Drive Shaft |
| (7) Needle Bearing            | (15) 24T Shifter Gear        |
| (8) 32T Gear                  | (16) Needle Bearing          |

W1268230

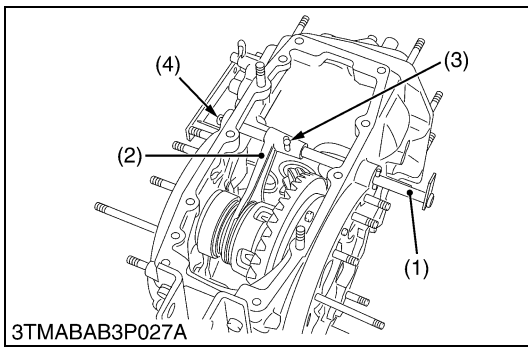

**Differential Lock Shift Fork**

1. Tap out the left side spring pin (4).
2. Remove the cotter pin and take out the clevis pin (3).
3. Draw out the differential lock fork shaft (1) and take out the differential lock shift fork (2).

**(When reassembling)**

- Apply grease to the left and right oil seals on the transmission case.
- Insert the clevis pin (3) from the top and install the washer and cotter pin.
- Tap in the spring pin (4) so that its split portion **a** may face outward as shown in the figure.

- (1) Differential Lock Fork Shaft
  - (2) Differential Lock Shift Fork
  - (3) Clevis Pin
  - (4) Spring Pin
- a : Split Portion**

W10744620

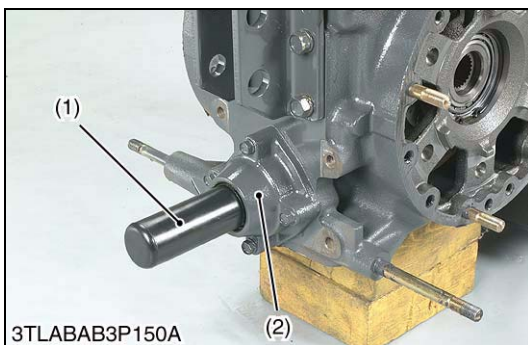
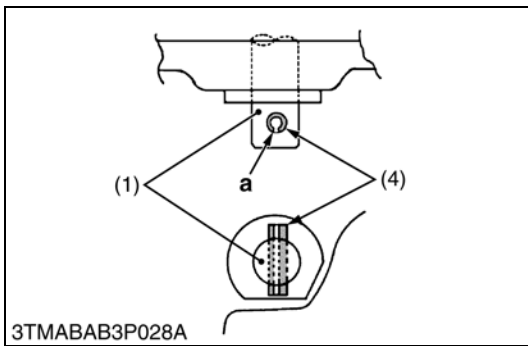

**PTO Shaft**

1. Remove the PTO shaft cover.
2. Remove the bearing case mounting screws, and draw out the PTO shaft (1) with bearing case (2).
3. Remove the internal snap ring (3).
4. Top out the PTO shaft (1) to the front.

**(When reassembling)**

- If the lock nut (6) was removed, replace it with a new one. After replacing, be sure to stake it firmly.
- Install the slinger (7) firmly.
- Apply grease to the oil seal (4) and install it, noting its direction.

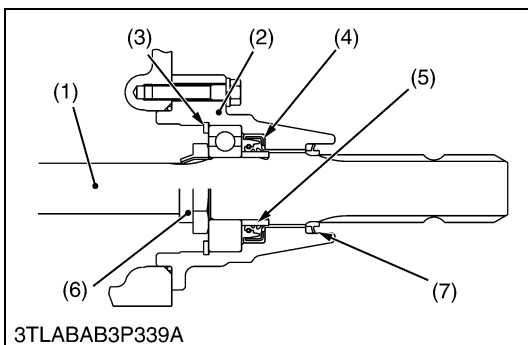

Tightening torque	Lock nut	147 to 196 N·m 15 to 20 kgf·m 108 to 145 ft·lbs
	Bearing case mounting screw	23.5 to 27.5 N·m 2.4 to 2.8 kgf·m 17.4 to 20.3 ft·lbs

- (1) PTO Shaft
- (2) Bearing Case
- (3) Internal Snap Ring
- (4) Oil Seal
- (5) Oil Seal Collar
- (6) Lock Nut
- (7) Slinger

W12700450

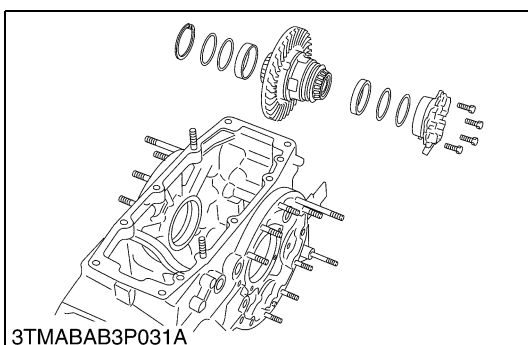

**Differential Gear Assembly**

1. Remove the differential support, noting the number of left shims.
2. Take out the differential gear assembly, noting the number of right shims.

**(When reassembling)**

- Check the spiral bevel gear for wear or damage. If it is no longer serviceable, replace it. Then, also replace the spiral bevel pinion.
- Use same number of shims as before disassembling.

Tightening torque	Differential support mounting screw	48.1 to 55.9 N·m 4.9 to 5.7 kgf·m 35.4 to 41.2 ft·lbs
-------------------	-------------------------------------	---

W10750520



**(3) Servicing****(A) Bearing, Gear and Shaft**

See page 3-S43.

**(B) PTO Clutch**

See page 3-S45.

**(C) Differential Gears**

See page 3-S46 to 3-S48.

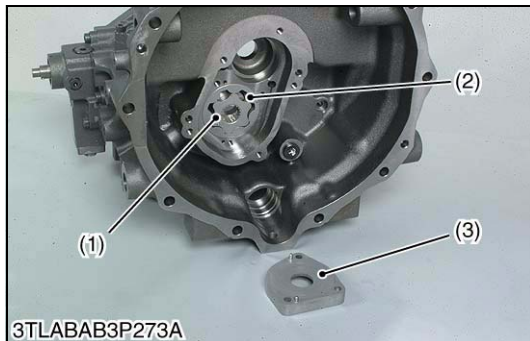
**(D) HST****Charge Pump**

1. Check the charge pump housing and the rotor (1), (2) for scratches and wear.
2. If scratch or worn, replace the charge pump complete assembly.

- |                 |                |
|-----------------|----------------|
| (1) Inner Rotor | (3) Pump Cover |
| (2) Outer Rotor |                |

W1025956

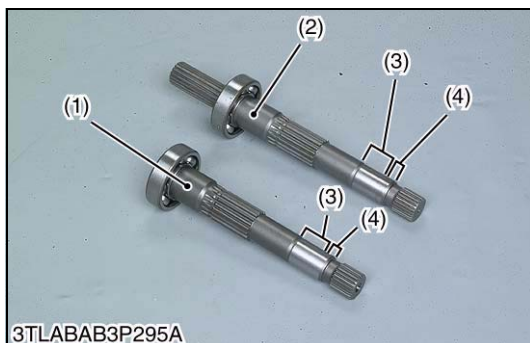
**Pump Shaft and Motor Shaft**

1. Check the seal surface (4) and the bearing surface (3).
2. If the shaft is rough or groove, replace it.

- |                 |                     |
|-----------------|---------------------|
| (1) Motor Shaft | (3) Bearing Surface |
| (2) Pump Shaft  | (4) Seal Surface    |

W1026037

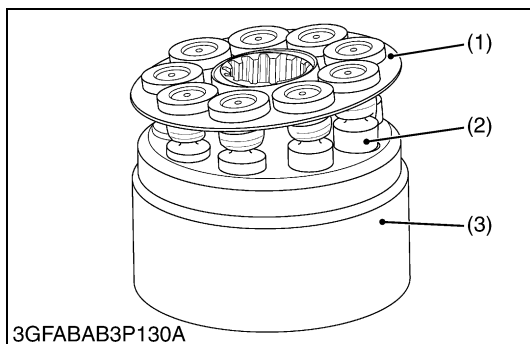
**Cylinder Block Bore and Pistons**

1. Lift the pistons gently with the retainer plate (1).
2. Check the pistons for their free movement in the cylinder block bores.
3. If the piston or the cylinder block bore is scored, replace cylinder block assembly.

**■ IMPORTANT**

- **Do not interchange pistons between pump and motor cylinder block.**

- |                    |                    |
|--------------------|--------------------|
| (1) Retainer Plate | (3) Cylinder Block |
| (2) Piston         |                    |

W1026142

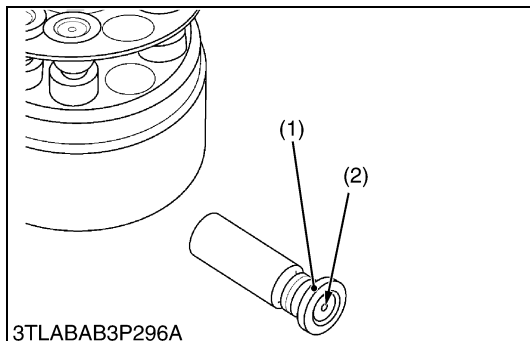
**Piston Slipper**

1. Check the slipper (1) for flatness.
2. If rounded, replace.
3. Measure the thickness of piston slipper.
4. If the measurement is less than the allowable limit, replace.
5. Check the lubricant hole (2) for clogging.

**■ IMPORTANT**

- **Do not interchange pistons between pump and motor cylinder block.**

- |                    |                    |
|--------------------|--------------------|
| (1) Piston Slipper | (2) Lubricant Hole |
|--------------------|--------------------|

W1026561

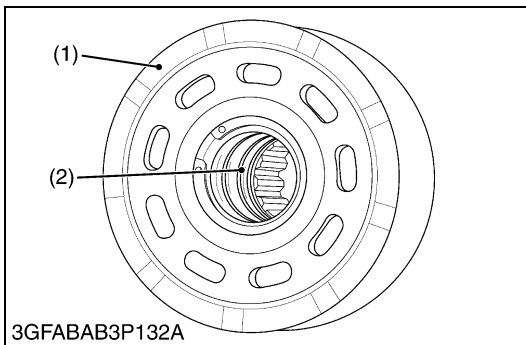

### Cylinder Block Face

1. Check the polished face (1) of cylinder block for scoring.
2. If scored, replace cylinder block assembly.
3. Check the spring (2) for breakage.
4. If broken, replace cylinder block assembly.

(1) Polished Face (2) Spring

W1026700

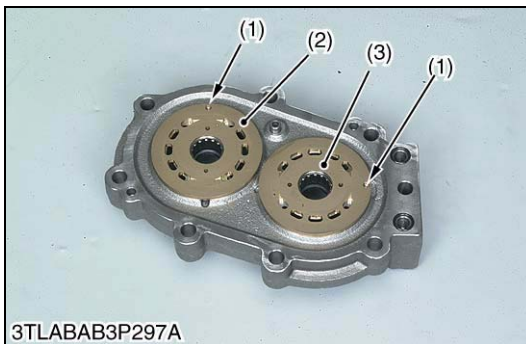

### Valve Plate

1. Check the engagement of the valve plate (2), (3) and the anchor pin (1).
2. Pushing the valve plate against the anchor pin, lift it to remove.
3. Check the valve plate for foreign particles.
4. Clean the valve plate and dry with compressed air.
5. Check the valve plate for scratches, wear and erosion. (Run a finger nail across the valve plate surface. If worn, it will be felt.)
6. If worn or scored, replace.

#### ■ NOTE

- After checking, coat them with transmission oil.
- Valve plates are not interchangeable.

(1) Anchor Pin (3) Valve Plate (Motor)  
(2) Valve Plate (Pump)

W1026799

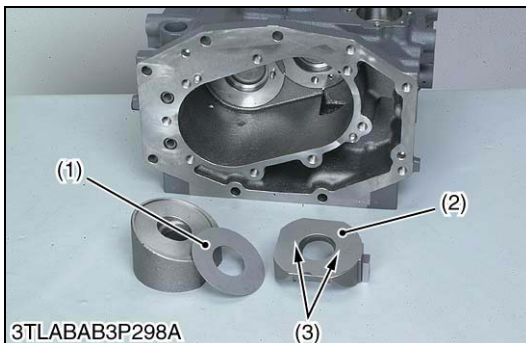

### Thrust Plate, Swashplate and Cradle Bearing

1. Check the thrust plate (1) for scratches and excessive wear.
2. If worn or scored, replace
3. Check the piston contact face of swashplate (2) for scratched and excessive wear and check the holes (3) of swashplate (2) for clogged.
4. If worn or scored, replace and if holes are clogged, clean them.
5. Check the surface of cradle bearings (4) for scratches and excessive wear.
6. If worn or scored, replace.

(1) Thrust Plate (4) Cradle Bearing  
(2) Swashplate (5) Cradle Bearing Bracket  
(3) Hole

W1026952

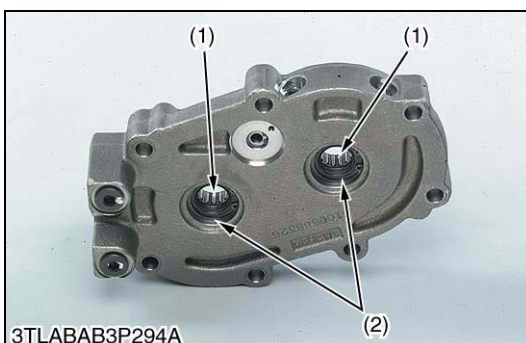
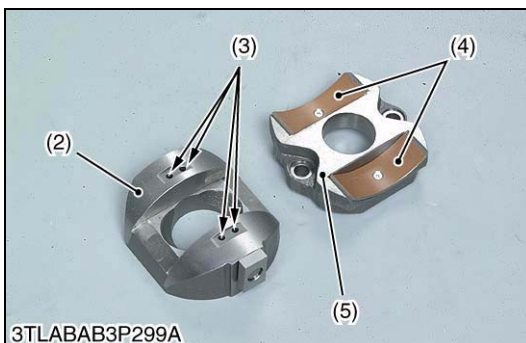

### Oil Seals and Bearing for Shaft

1. Remove the internal snap ring and check the oil seals (2) for damage.
2. Check the bearings (1) for wear.
3. If the bearings are worn, replace.

#### ■ NOTE

- After checking, coat the bearing with transmission oil and the oil seal lip with grease.

(1) Needle Bearing (2) Oil Seal

W1027176

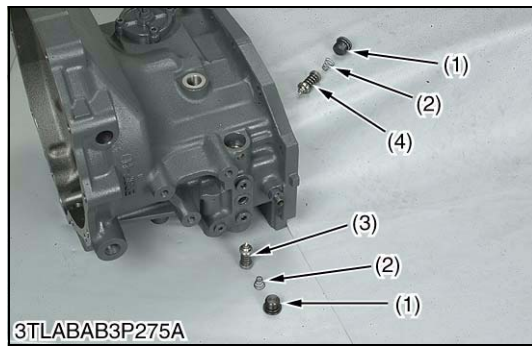

### Check and High Pressure Relief Valve

1. Check the valve plug (1) and valve (3), (4) for scratches and damage.
2. Check the valve seat in the port block for damage.
3. Check the spring (2) for breakage and wear.
4. If anything unusual, replace the check and high pressure relief valve assembly.

- |   |   |
|---|---|
| (1) Valve Plug  | (4) Check and High Pressure Relief Valve Assembly (Reverse) |
| (2) Spring  |   |
| (3) Check and High Pressure Relief Valve Assembly (Forward) |   |

W1027291

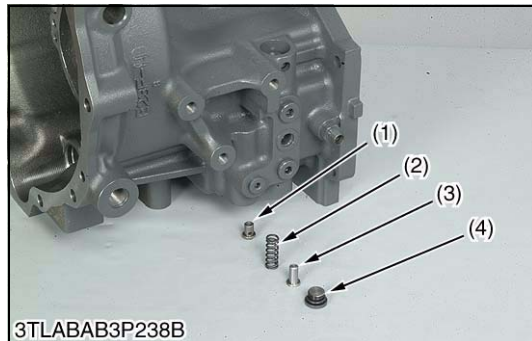

### Charge Relief Valve

1. Check the spring guide (3), spring (2) and valve poppet (1) for scratches, breakage and damage.
2. If anything unusual. replace.

#### ■ NOTE

- **When re-installing the charge relief valve, never change the number of shims.**
- **If replace with new one, be sure to check and adjust the setting pressure. (See page 3-S88.)**

- |                  |                                  |
|------------------|----------------------------------|
| (1) Valve Poppet | (3) Spring Guide                 |
| (2) Spring       | (4) Plug for Charge Relief Valve |

W1027404

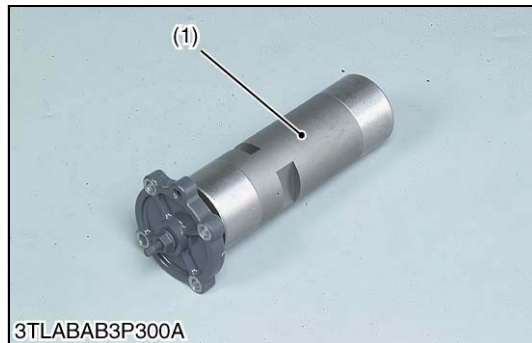

### Servo Piston

1. Check the surface of servo piston for scratches and excessive wear.
2. If worn or scored, replace the servo piston assembly.

- |                           |
|---------------------------|
| (1) Servo Piston Assembly |
|---------------------------|

W1027526

# 4 REAR AXLE

# MECHANISM

## CONTENTS

1. STRUCTURE .....	4-M1
--------------------	------

# 1. STRUCTURE

[L3130, L3430, L3830, L4630]

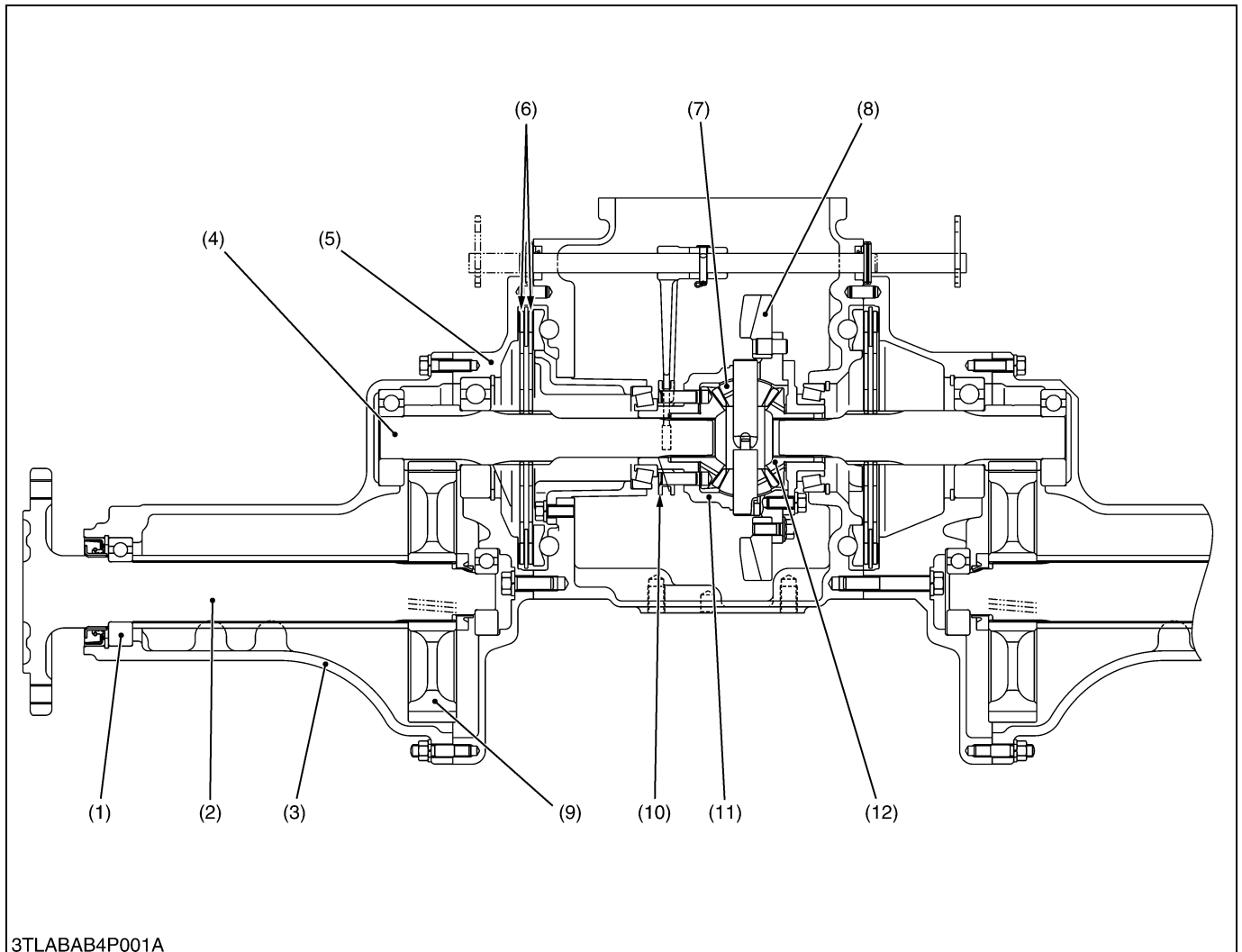

3TLABAB4P001A

- |                    |                             |                         |                                |
|--------------------|-----------------------------|-------------------------|--------------------------------|
| (1) Ball Bearing   | (4) Differential Gear Shaft | (7) Differential Pinion | (10) Differential Lock Shifter |
| (2) Rear Axle      | (5) Brake Case              | (8) Ring Gear           | (11) Differential Case         |
| (3) Rear Axle Case | (6) Brake Disc              | (9) Final Gear          | (12) Differential Side Gear    |

The final gear (9) are final reduction mechanism which further reduces the speed of rotation. The direction of power transmitted is changed by the differential gear.

The rear axles (2) are the final transmission mechanism which transmit the power from the transmission to the rear wheels. The rotation speed is reduced by the final gears (9).

The rear axles are the semi-floating type with the ball bearing (1) between the rear axle (2) and rear axle case (3), which support the rear wheel load besides transmitting power to the rear wheel. The rear axles also support the weight of the tractor.

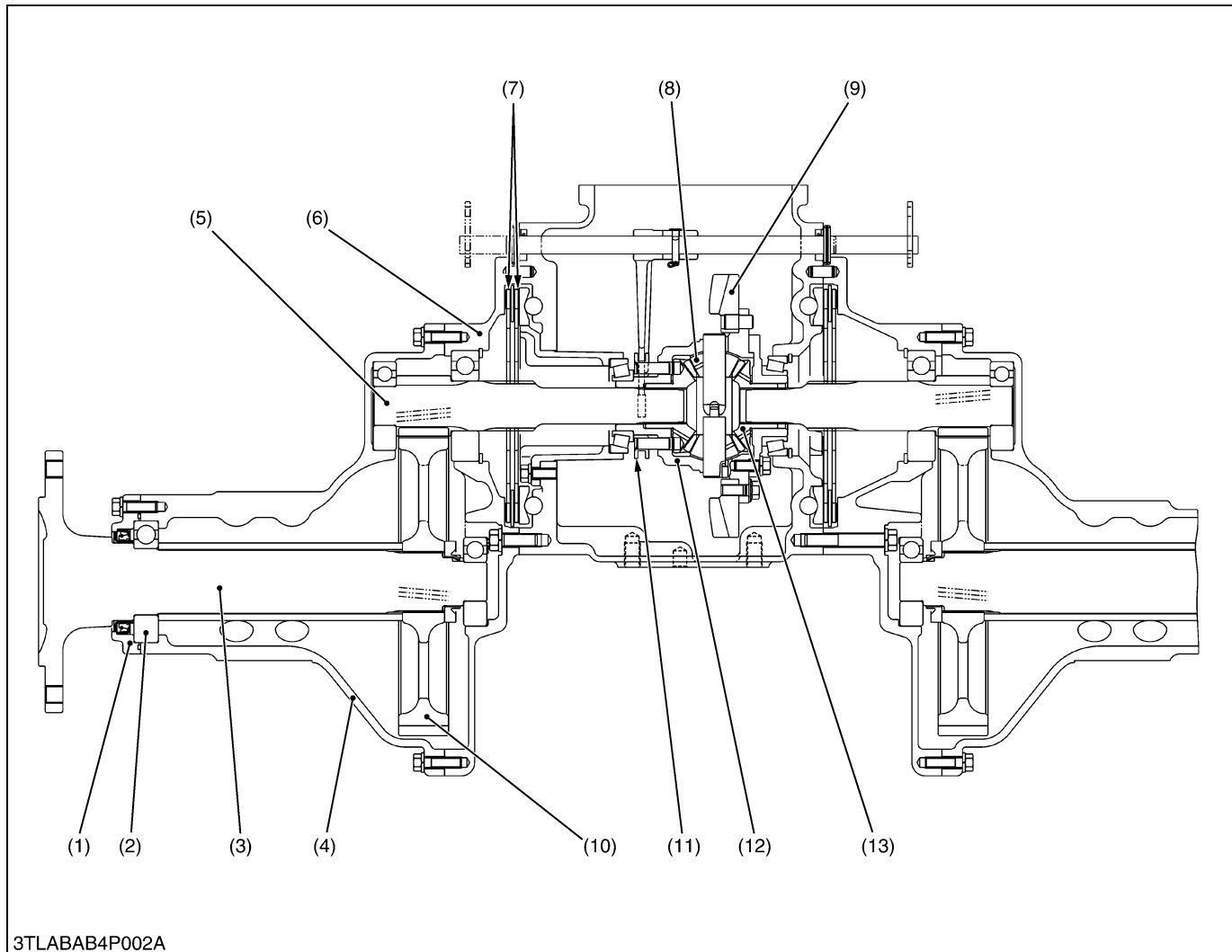

**[L5030]**

3TLABAB4P002A

- |                     |                             |                         |                                |
|---------------------|-----------------------------|-------------------------|--------------------------------|
| (1) Rear Axle Cover | (5) Differential Gear Shaft | (8) Differential Pinion | (11) Differential Lock Shifter |
| (2) Ball Bearing    | (6) Brake Case              | (9) Ring Gear           | (12) Differential Case         |
| (3) Rear Axle       | (7) Brake Disc              | (10) Final Gear         | (13) Differential Side Gear    |
| (4) Rear Axle Case  |                             |                         |                                |

# SERVICING

## CONTENTS

1. TROUBLESHOOTING .....	4-S1
2. TIGHTENING TORQUES .....	4-S2
3. CHECKING, DISASSEMBLING AND SERVICING.....	4-S3
[1] DISASSEMBLING AND ASSEMBLING.....	4-S3
(1) Separating Rear Axle Case from Brake Case .....	4-S3
(2) Disassembling Rear Axle .....	4-S6

# 1. TROUBLESHOOTING

Symptom	Probable Cause	Solution	Reference Page
<b>Excessive or Unusual Noise at All Time</b>	<ul style="list-style-type: none"> <li>• Improper backlash between differential gear shaft and final gear</li> <li>• Bearing worn</li> <li>• Insufficient or improper type of transmission fluid used</li> </ul>	Replace  Replace Replenish or change	4-S6  – G-7, 8
<b>Noise while Turning</b>	<ul style="list-style-type: none"> <li>• Differential gear shaft and final gear worn or damaged</li> </ul>	Replace	4-S6

W10122140

## 2. TIGHTENING TORQUES

Tightening torques of screws and nuts on the table below are especially specified.  
(For general use screws and nuts : See page G-10.)

Item	N·m	kgf·m	ft-lbs
Rear wheel mounting screw and nut	215	22	160
Rear wheel mounting stud bolt	98.1 to 112.8	10.0 to 11.5	72.3 to 83.2
ROPS lower frame mounting screw	166.7 to 196.1	17 to 20	123 to 144
Cabin mounting bolt and nut	124 to 147	13.0 to 15.0	91.0 to 108.0
Cabin mount bracket mounting screw	166.7 to 196.1	17 to 20	123 to 144
Rear axle case mounting screw (M10)	48.1 to 55.9	4.9 to 5.7	35.4 to 41.2
Rear axle case mounting nut (M10, 9T)	60.8 to 70.5	6.2 to 7.2	44.9 to 52.1
Rear axle case mounting screw (M12)	77.5 to 90.2	7.9 to 9.2	57.1 to 66.5
Rear axle case mounting stud bolt	24.5 to 31.4	2.5 to 3.2	18.1 to 23.1
Rear axle lock nut	196 to 245	20 to 25	145 to 181

W10127360

## 3. CHECKING, DISASSEMBLING AND SERVICING

### [1] DISASSEMBLING AND ASSEMBLING

#### (1) Separating Rear Axle Case from Brake Case

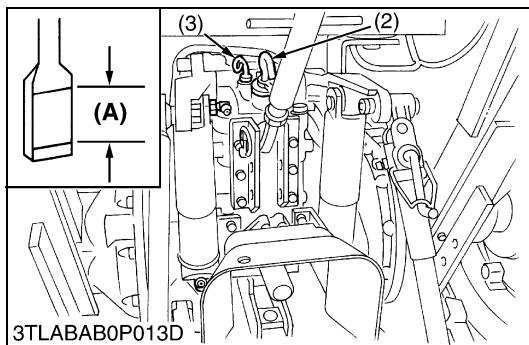
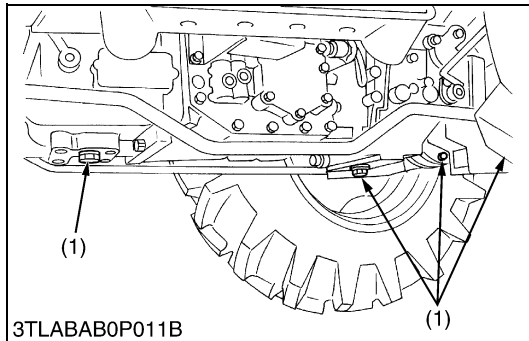

#### Draining the Transmission Fluid

1. Place oil pans underneath the transmission case.
2. Remove the drain plugs (1).
3. Drain the transmission fluid.
4. Reinstall the drain plugs (1).

#### **(When refilling)**

- Fill up from filling port after removing the filling plug (2) until reaching the upper notch on the dipstick (3).
- After running the engine for few minutes, stop it and check the oil level again, add the fluid to prescribed level if it is not correct level.

Transmission fluid capacity	L3130 L3430	42 L 11.1 U.S.gals 9.2 Imp.gals
	L3830 L4630	43 L 11.4 U.S.gals 9.5 Imp.gals
	L5030	45 L 11.9 U.S.gals 9.9 Imp.gals

#### ■ IMPORTANT

- **Use only KUBOTA SUPER UDT fluid. Use of other oils may damage the transmission or hydraulic system. Refer to "LUBRICANTS, FUEL AND COOLANT". (See page G-7, 8.)**
- **Do not mix different brands of fluid together.**

- (1) Drain Plugs  
(2) Filling Plug  
(3) Dipstick

(A) Oil level is acceptable within this range.

W1012666

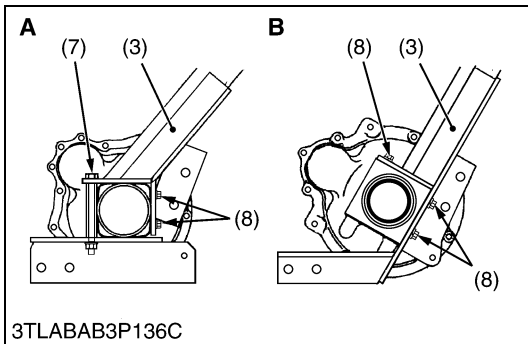
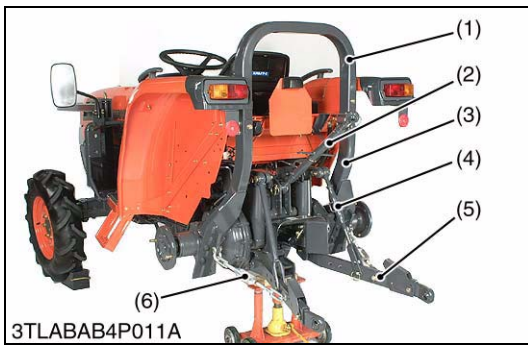

**Rear Wheel and ROPS (ROPS Model)**

1. Place the disassembling stand under the transmission case.
2. Remove the rear wheel mounting screws and nuts.
3. Remove the rear wheels.
4. Remove the top link (2) and lift rod (4).
5. Disconnect the check chain (6) and remove the lower link (5).
6. Remove the ROPS lower frame mounting screws (7), (8).
7. Dismount the ROPS assembly (1), (3).

**(When reassembling)**

Tightening torque	Rear wheel mounting screw and nut	215 N-m 22 kgf-m 160 ft-lbs
	Rear wheel mounting stud bolt	98.1 to 112.8 N-m 10.0 to 11.5 kgf-m 72.3 to 83.2 ft-lbs
	ROPS lower frame mounting screw	166.7 to 196.1 N-m 17 to 20 kgf-m 123 to 144 ft-lbs

- |                      |                         |
|----------------------|-------------------------|
| (1) ROPS Upper Frame | (7) Screw (M14 × 155)   |
| (2) Top Link         | (8) Screw (M14 × 30)    |
| (3) ROPS Lower Frame |                         |
| (4) Lift Rod         | <b>A : L3130, L3430</b> |
| (5) Lower Link       | <b>B : L3830, L4630</b> |
| (6) Check Chain      |                         |

W10110430

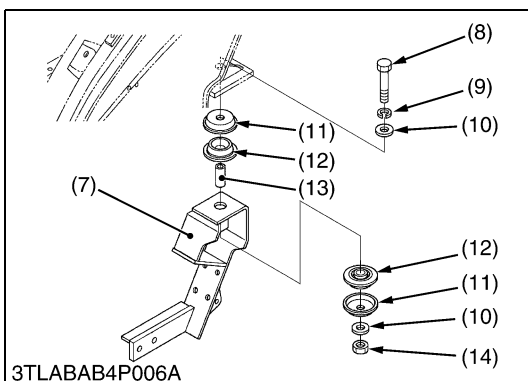
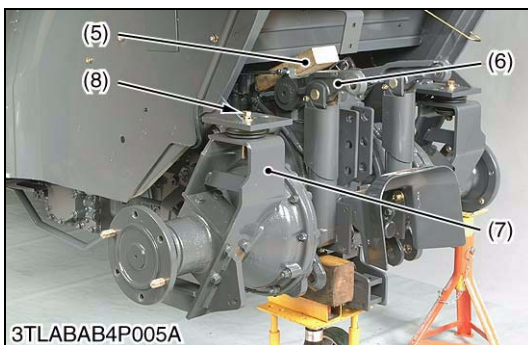

**Rear Wheel and Cabin Mount Screw (Cabin Model)**

1. Place the disassembling stand under the transmission case.
2. Remove the rear wheel mounting screws and nuts.
3. Remove the rear wheels.
4. Remove the top link (1) and lift rod (2).
5. Disconnect the check chain (4) and remove the lower link (3).
6. Place a block of wood (5) between cabin and lift arm (6) to support the cabin.
7. Remove the cabin mount bracket mounting bolt (8) and nut.

**(When reassembling)**

- Be sure to install the washers, plate and mount rubbers, etc. in their original positions.

Tightening torque	Rear wheel mounting screw and nut	215 N-m 22 kgf-m 160 ft-lbs
	Rear wheel mounting stud bolt	98.1 to 112.8 N-m 10.0 to 11.5 kgf-m 72.3 to 83.2 ft-lbs
	Cabin mounting bolt and nut	124 to 147 N-m 13.0 to 15.0 kgf-m 91.0 to 108.0 ft-lbs

- |                         |                     |
|-------------------------|---------------------|
| (1) Top Link            | (8) Bolt (M14 × 90) |
| (2) Lift Rod            | (9) Spring Washer   |
| (3) Lower Link          | (10) Plain Washer   |
| (4) Check Chain         | (11) Plate          |
| (5) Block of Wood       | (12) Mount Rubber   |
| (6) Lift Arm            | (13) Collar         |
| (7) Cabin Mount Bracket | (14) Nut            |

W1011906



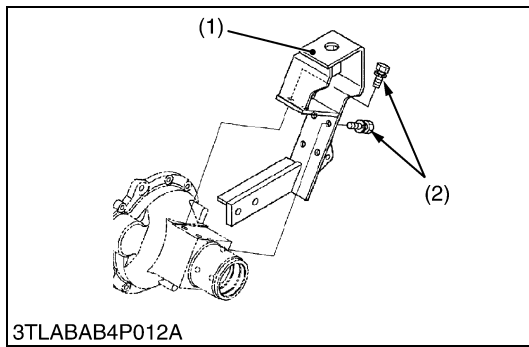

### Cabin Mount Bracket (Cabin Model)

1. Remove the cabin mount bracket (3), (4) or (6).

#### (When reassembling)

Tightening torque	Cabin mount bracket mounting screw	166.7 to 196.1 N·m 17 to 20 kgf·m 123 to 144 ft-lbs
-------------------	------------------------------------	---

(1) Cabin Mount Bracket

(2) Screw (M14 × 30)

W1013640



### Rear Axle Case

1. Disconnect the brake rod.
2. Place the disassembling stand under the rear axle case.
3. Remove the rear axle mounting screws and nuts.
4. Separate the rear axle case from brake case.

#### (When reassembling)

- Apply liquid gasket (Three Bond 1208D or equivalent) to joint face of the rear axle case and brake case.

Tightening torque	Rear axle case mounting screw and nut	M10 screw	48.1 to 55.9 N·m 4.9 to 5.7 kgf·m 35.4 to 41.2 ft-lbs
		M10 nut (9T) (Except L3130, L3430)	60.8 to 70.5 N·m 6.2 to 7.2 kgf·m 44.9 to 52.1 ft-lbs
		M12 screw (Except L3130, L3430)	77.5 to 90.2 N·m 7.9 to 9.2 kgf·m 57.1 to 66.5 ft-lbs
		Stud bolt	24.5 to 31.4 N·m 2.5 to 3.2 kgf·m 18.1 to 23.1 ft-lbs

W10113490

## (2) Disassembling Rear Axle

### Rear Axle

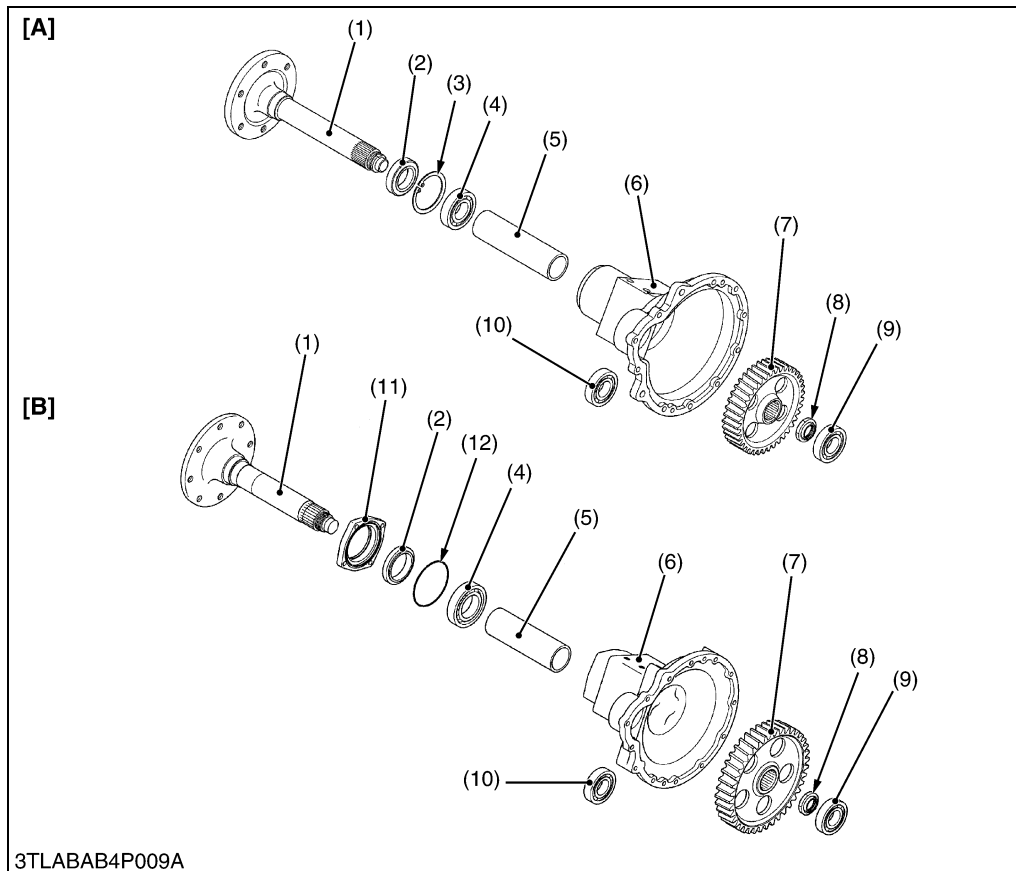

- (1) Rear Axle
- (2) Oil Seal
- (3) Internal Snap Ring
- (4) Ball Bearing
- (5) Spacer
- (6) Rear Axle Case
- (7) Gear
- (8) Lock Nut
- (9) Ball Bearing
- (10) Ball Bearing
- (11) Rear Axle Cover
- (12) O-ring

**[A] L3130, L3430, L3830,  
L4630**  
**[B] L5030**

W10115940

3TLABAB4P009A

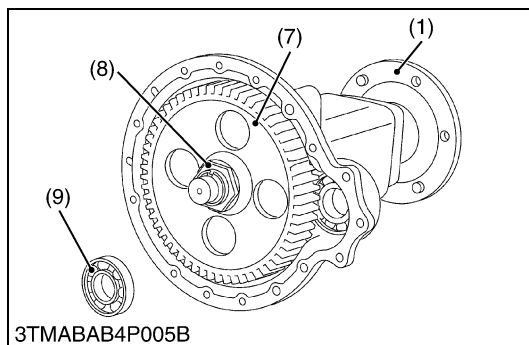

3TMABAB4P005B

1. Remove the ball bearing (9) with a puller.
2. Remove the stake of lock nut (8).
3. Secure the rear axle (1) in a vise and remove the lock nut.
4. Take out the gear (7) and spacer (5).
5. Tap out the rear axle (1).
6. Remove the rear axle cover (11). (L5030 only)

#### (When reassembling)

- Apply grease to the oil seal (2) and install it.
- Replace the lock nut with new one, and after tightening it to specified torque, stake it firmly.
- Assemble the oil seal (2) with correct direction. (See figure.)

Tightening torque	Lock nut	196 to 245 N·m 20 to 25 kgf·m 145 to 181 ft·lbs
-------------------	----------	---

W10116810

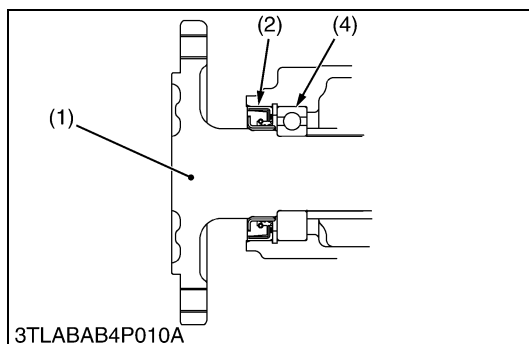

3TLABAB4P010A

# 5 BRAKES

# MECHANISM

## CONTENTS

1. LINKAGE.....	5-M1
2. OPERATION .....	5-M2

# 1. LINKAGE

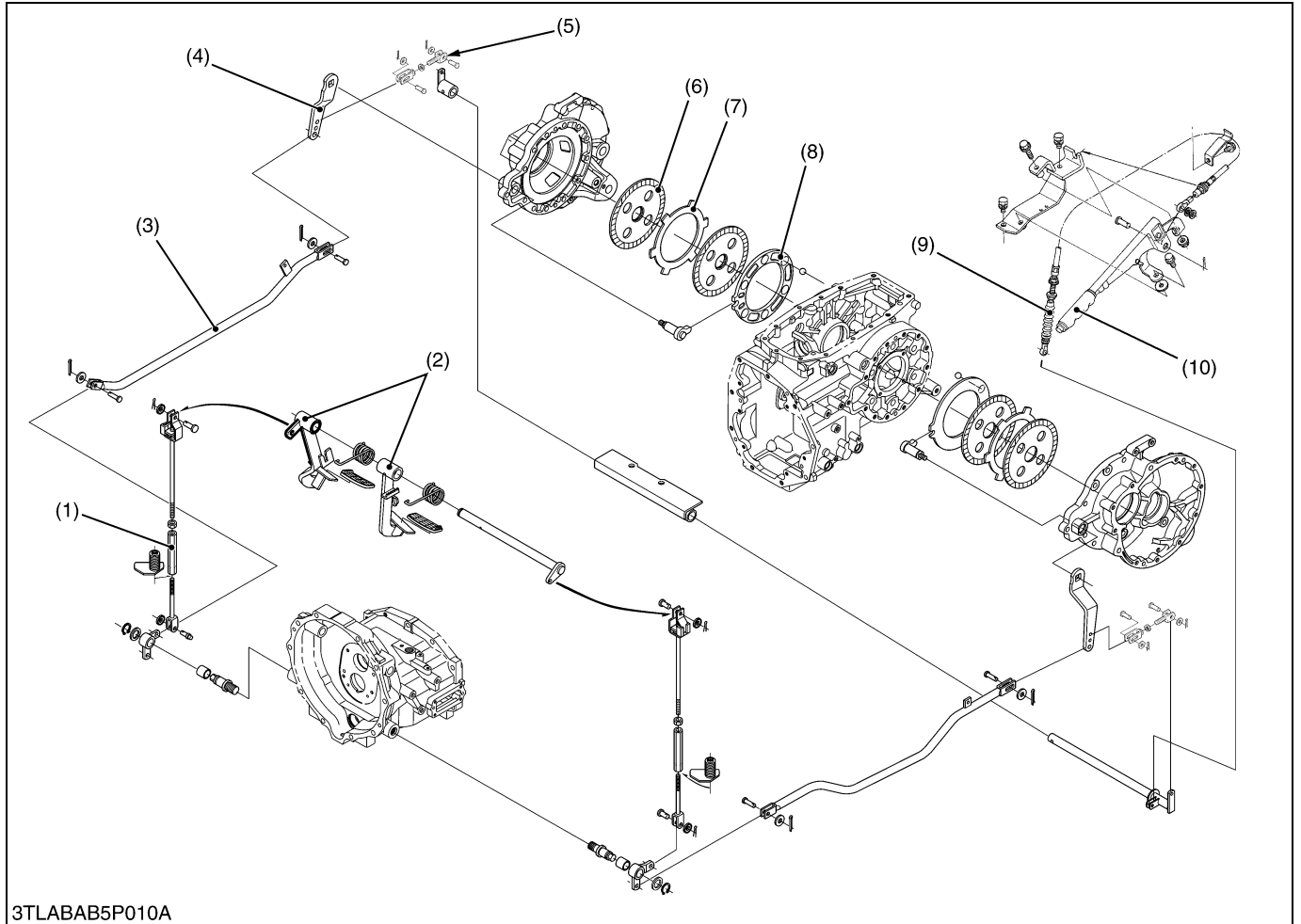

- |                                |                                  |                 |                          |
|--------------------------------|----------------------------------|-----------------|--------------------------|
| (1) Brake Pedal Turnbuckle Rod | (4) Brake Cam Lever              | (7) Brake Plate | (9) Parking Brake Cable  |
| (2) Brake Pedal                | (5) Parking Brake Turnbuckle Rod | (8) Cam Plate   | (10) Parking Brake Lever |
| (3) Brake Rod                  | (6) Brake Disc                   |                 |                          |

## 2. OPERATION

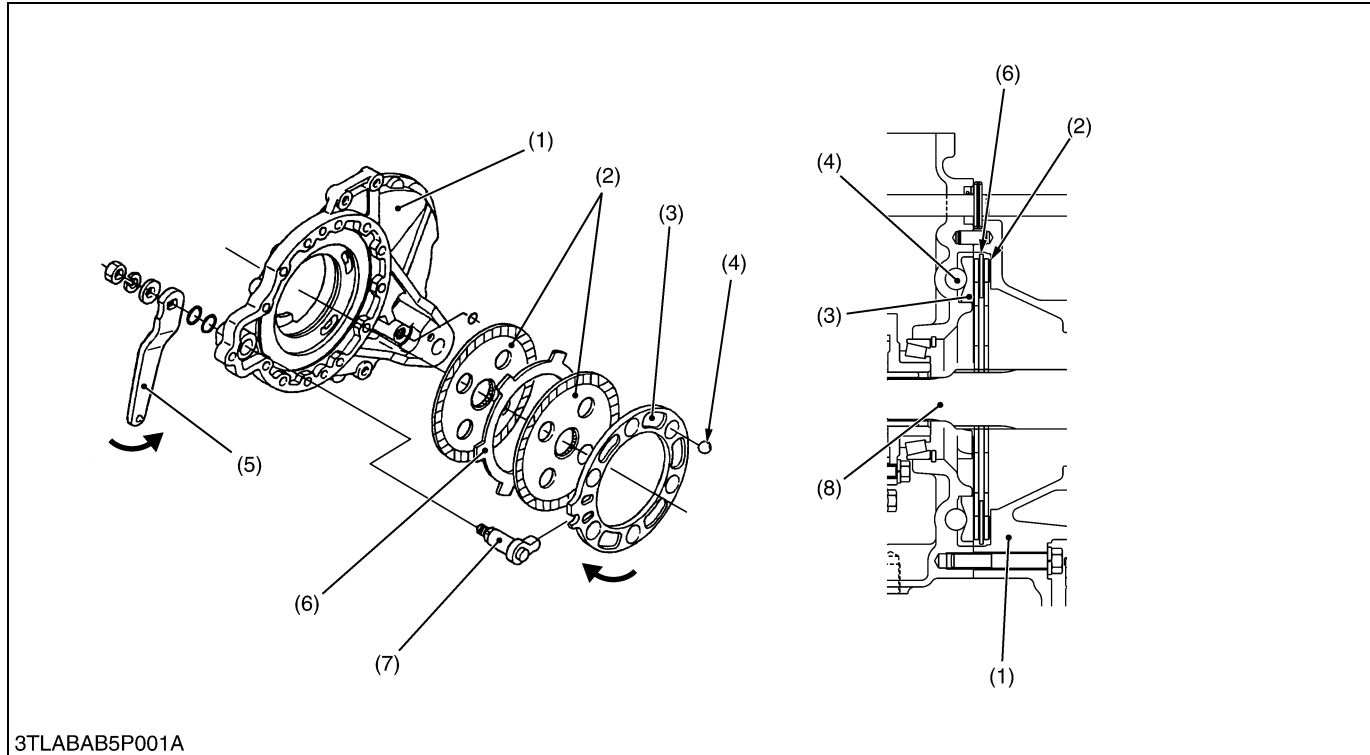

3TLABAB5P001A

- |                |                |                     |                 |
|----------------|----------------|---------------------|-----------------|
| (1) Brake Case | (3) Cam Plate  | (5) Brake Cam Lever | (7) Brake Cam   |
| (2) Brake Disc | (4) Steel Ball | (6) Plate           | (8) Brake Shaft |

The brakes are provided on the power transmitting shafts (brake shafts (8)) through which power is transmitted to the final reduction system. The brakes are incorporated in the brake case (1) filled with transmission oil. They are designed to brake when the brake discs (2), spline-coupled and rotating with the brake shaft, are pressed against the brake case by cam plate (3) with the cam mechanism incorporating steel balls (4). For greater braking force, two brake discs are provided respectively, and the plate (6) fixed to the brake case are arranged between the brake discs.

### ■ During Braking

When the brake pedal is pressed, the force causes the brake cam lever (5) to move in the direction of arrow through the brake rod. At the same time, the brake cam (7) spline-couples with the brake cam lever also moves. Due to this force, cam plate (3) moves in the direction of arrow. Since the steel balls (4) are set in the grooves of differential case, cam plate (3) is pushed out against the brake discs (2), causing braking with the friction force created.



# SERVICING

## CONTENTS

1. TROUBLESHOOTING .....	5-S1
2. SERVICING SPECIFICATIONS .....	5-S2
3. TIGHTENING TORQUES .....	5-S3
4. CHECKING, DISASSEMBLING AND SERVICING.....	5-S4
[1] BRAKE PEDAL .....	5-S4
(1) Checking and Adjusting .....	5-S4
(2) Disassembling and Assembling .....	5-S4
(3) Servicing .....	5-S7
[2] BRAKE CASE .....	5-S7
(1) Disassembling and Assembling .....	5-S7
(2) Servicing .....	5-S11

# 1. TROUBLESHOOTING

Symptom	Probable Cause	Solution	Reference Page
<b>Uneven Braking Force</b>	<ul style="list-style-type: none"> <li>• Brake pedal play unevenly adjusted</li> <li>• Brake disc worn</li> <li>• Cam plate warped</li> </ul>	Adjust Replace Replace	5-S4 5-S11 5-S11
<b>Brake Drags</b>	<ul style="list-style-type: none"> <li>• Brake pedal play too small</li> <li>• Ball holes of cam plate for uneven wear</li> <li>• Brake pedal return spring weaken or broken</li> <li>• Brake cam rusted</li> </ul>	Adjust Replace Replace Repair	5-S4 5-S11 5-S6 5-S11
<b>Poor Braking Force</b>	<ul style="list-style-type: none"> <li>• Brake pedal play excessive</li> <li>• Brake disc worn</li> <li>• Cam plate warped</li> <li>• Brake cam or lever damaged</li> <li>• Transmission fluid improper</li> </ul>	Adjust Replace Replace Replace Change	5-S4 5-S11 5-S11 5-S11 G-7, 8

W10143220

## 2. SERVICING SPECIFICATIONS

Item		Factory Specification	Allowable Limit
Brake Pedal	Free Travel	15 to 20 mm 0.6 to 0.8 in.	–
Brake Lever Link Shaft to Bushing	Clearance	0.12 to 0.25 mm 0.0047 to 0.0098 in.	1.0 mm 0.039 in.
Brake Lever Link Shaft	O.D.	19.90 to 19.98 mm 0.7835 to 0.7866 in.	–
Brake Lever Link Bushing	I.D.	20.10 to 20.15 mm 0.7913 to 0.7933 in.	–
Cam Plate	Flatness	–	0.3 mm 0.012 in.
Cam Plate and Ball	Height	20.9 to 21.1 mm 0.823 to 0.831 in.	20.5 mm 0.8071 in.
Brake Disc	Thickness	4.6 to 4.8 mm 0.181 to 0.189 in.	4.2 mm 0.165 in.
Plate	Thickness	2.54 to 2.66 mm 0.1000 to 0.1047 in.	2.1 mm 0.0827 in.

W10138740

### 3. TIGHTENING TORQUES

Tightening torques of screws and nuts in the table below are especially specified.  
(For general use screws and nuts: See page G-10.)

Item	N·m	kgf·m	ft-lbs
Rear wheel mounting screw and nut	215	22	166
Rear wheel mounting stud bolt	98.1 to 112.8	10.0 to 11.5	72.3 to 83.2
ROPS lower frame mounting screw	166.7 to 196.1	17 to 20	123 to 144
Cabin mounting bolt and nut	124 to 147	13.0 to 15.0	91.0 to 108.0
Cabin mount bracket mounting screw	166.7 to 196.1	17 to 20	123 to 144
Rear axle case mounting screw (M10)	48.1 to 55.9	4.9 to 5.7	35.4 to 41.2
Rear axle case mounting nut (M10, 9T)	60.8 to 70.5	6.2 to 7.2	44.9 to 52.1
Rear axle case mounting screw (M12)	77.5 to 90.2	7.9 to 9.2	57.1 to 66.5
Rear axle case mounting stud bolt	24.5 to 31.4	2.5 to 3.2	18.1 to 23.1
Brake case mounting screw and nut	77.5 to 90.2	7.9 to 9.2	57.1 to 66.5
Floor seat mounting bolt and nut	196 to 225	20 to 23	145 to 166
Brake case mounting stud bolt	38.2 to 45.1	3.9 to 4.6	28.2 to 33.3
Brake cam lever mounting nut	62.8 to 72.5	6.4 to 7.4	46.3 to 53.5

W10127360

## 4. CHECKING, DISASSEMBLING AND SERVICING

### [1] BRAKE PEDAL

#### (1) Checking and Adjusting

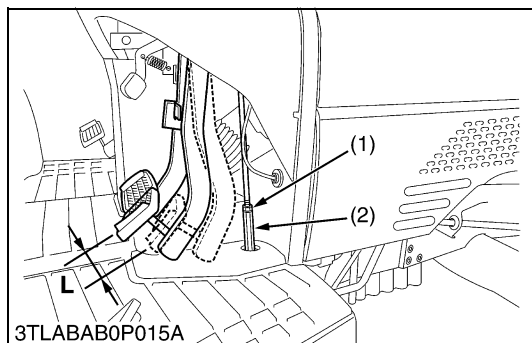

#### Checking Brake Pedal Free Travel

##### ⚠ CAUTION

- Stop the engine and chock the wheels before checking brake pedal.

1. Release the parking brake.
2. Slightly depress the brake pedals and measure free travel (L) at top of pedal stroke.
3. If the measurement is not within the factory specifications, loosen the lock nut (1) and turn the turnbuckle (2) to adjust the rod length within acceptable limits.
4. Retighten the lock nut (1) securely.

Keep the free travel in the right and left brake pedals equal.

Brake pedal free travel "L"	Factory spec.	15 to 20 mm 0.59 to 0.79 in.
-----------------------------	---------------	---------------------------------

- (1) Lock Nut  
(2) Turnbuckle

L : Free Travel

W1015392



#### Parking Brake Lever Free Play

##### ⚠ CAUTION

- Stop the engine and chock the wheels before checking parking lever.

1. Release the parking brake lever (1).
2. Measure the length of L.
3. Confirm there is free play in a right and left parking brake rod (3).
4. Adjust the parking brake rod (3) length to become the same when right and left free play is different at that time.
5. Pull the parking lever (1) by one notch. At that time confirm there is no free play in the parking brake rods.
6. Adjust the parking brake cable (2) if there is free play in the parking brake rod (3).

##### (Reference)

Parking brake cable length L	Factory spec.	108 to 112 mm 4.25 to 4.41 in.
------------------------------	---------------	-----------------------------------

- (1) Parking Brake Lever  
(2) Parking Brake Cable

(3) Parking Brake Rod

W1013757

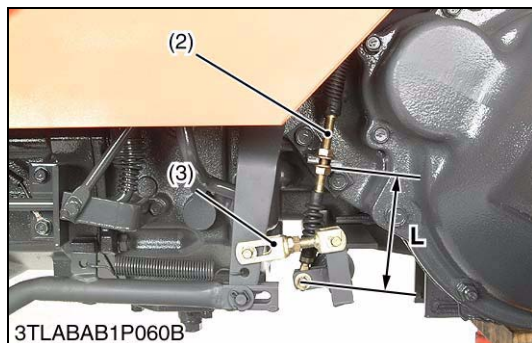

#### (2) Disassembling and Assembling



##### Panel Cover

1. Remove the combination switch (2).
2. Remove the panel cover (1).

(1) Panel Cover

(2) Combination Switch

W1017418

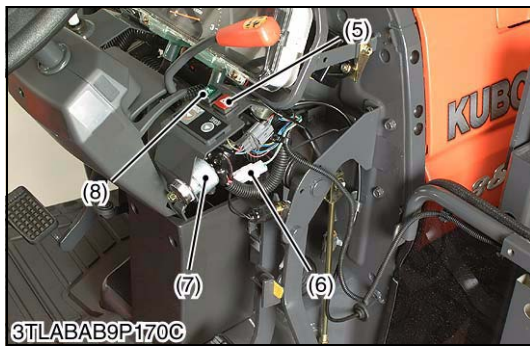
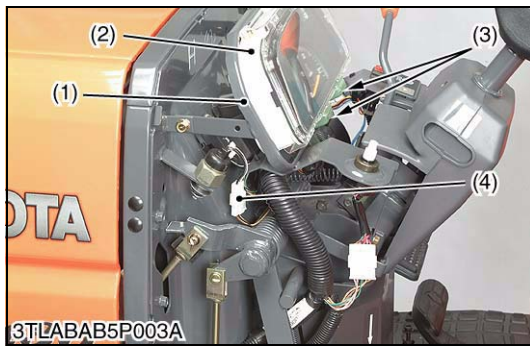

### IntelliPanel (Electronic Instrument Panel)

1. Disconnect the panel connectors (3) and combination switch connector (4).
2. Disconnect the hazard connector position light connector, main switch connector (6) and mode switch connector (7).
3. Remove the electronic instrument panel (2) with panel frame (1) as a unit.

- |                                  |                           |
|----------------------------------|---------------------------|
| (1) Panel Frame                  | (5) Hazard Switch         |
| (2) Electronic Instrument Panel  | (6) Main Switch Connector |
| (3) Panel Connector              | (7) Mode Switch Connector |
| (4) Combination Switch Connector | (8) Position Light Switch |

W1017912

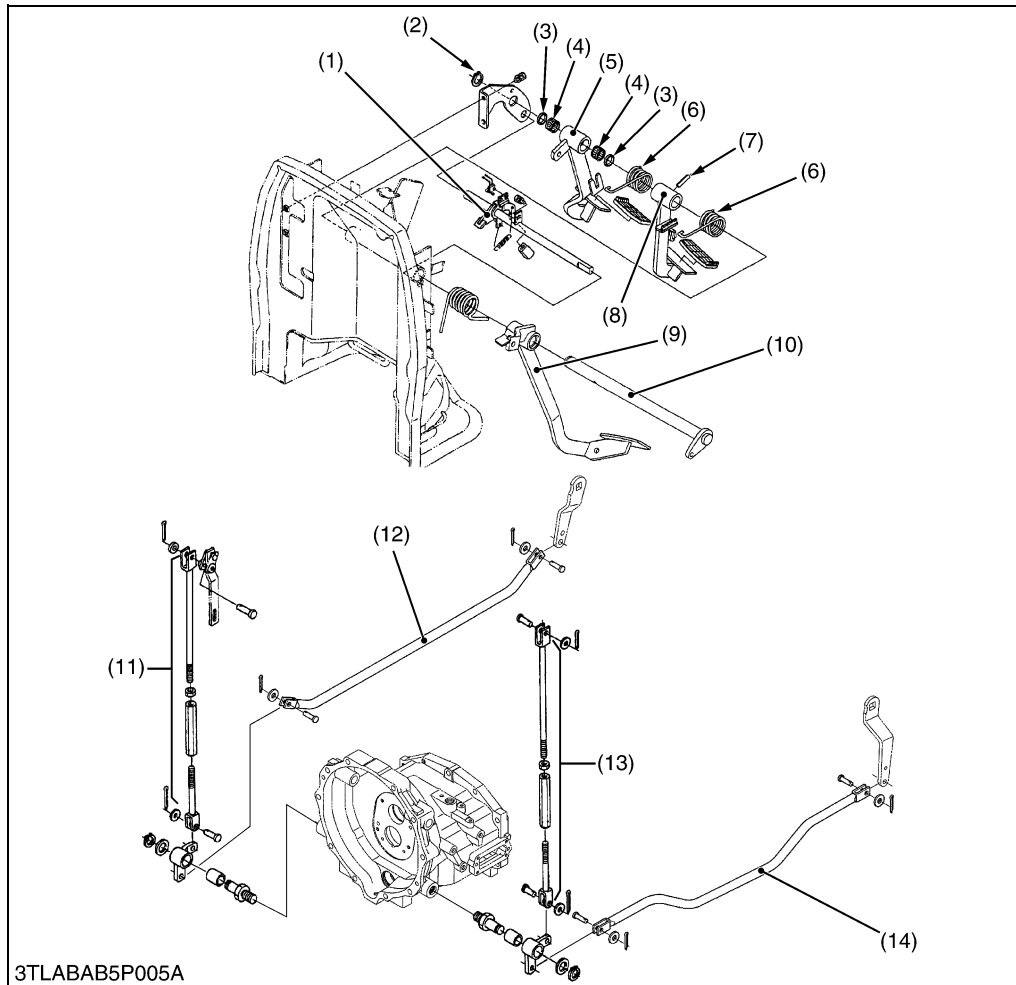

**Brake Pedal and Brake Rod**

- (1) Parking Brake Lever
- (2) External Snap Ring
- (3) Oil Seal
- (4) Needle Bearing
- (5) Brake Pedal RH
- (6) Spring
- (7) Spring Pin
- (8) Brake Pedal LH
- (9) Clutch Pedal
- (10) Brake Pedal Shaft
- (11) Brake Pedal Rod RH
- (12) Brake Rod RH
- (13) Brake Pedal Rod LH
- (14) Brake Rod LH

W1012974

3TLABAB5P005A

1. Remove the brake rods (12), (14).
2. Remove the brake pedal rods (11), (13).
3. Disconnect the clutch pedal rod.
4. Remove the external snap ring (2).
5. Tap out the spring pin (7) and pull out the brake pedal shaft (10) with clutch pedal (9).
6. Remove the brake pedals (5), (8) and springs (6).
7. Remove the parking brake lever (1).



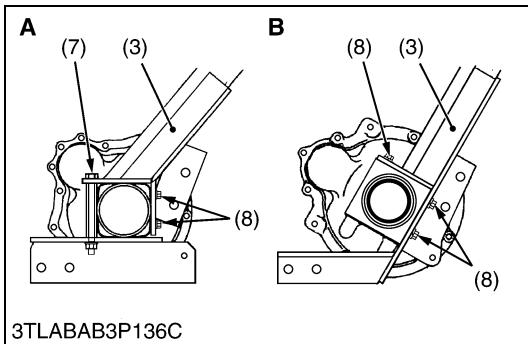
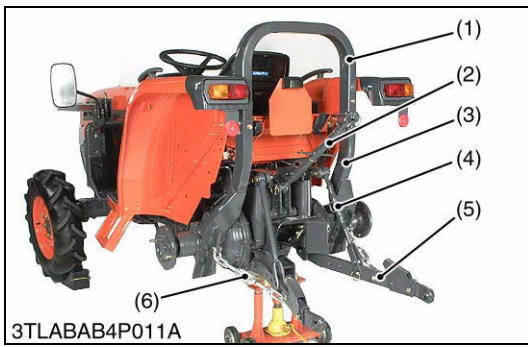

**Rear Wheel and ROPS (ROPS Model)**

1. Place the disassembling stand under the transmission case.
2. Remove the rear wheel mounting screws and nuts.
3. Remove the rear wheels.
4. Remove the top link (2) and lift rod (4).
5. Disconnect the check chain (6) and remove the lower link (5).
6. Remove the ROPS lower frame mounting screws (7), (8).
7. Dismount the ROPS assembly (1), (3).

**(When reassembling)**

Tightening torque	Rear wheel mounting screw and nut	215 N-m 22 kgf-m 160 ft-lbs
	Rear wheel mounting stud bolt	98.1 to 112.8 N-m 10.0 to 11.5 kgf-m 72.3 to 83.2 ft-lbs
	ROPS lower frame mounting screw	166.7 to 196.1 N-m 17 to 20 kgf-m 123 to 144 ft-lbs

- (1) ROPS Upper Frame
  - (2) Top Link
  - (3) ROPS Lower Frame
  - (4) Lift Rod
  - (5) Lower Link
  - (6) Check Chain
  - (7) Screw (M14 × 155)
  - (8) Screw (M14 × 30)
- A : L3130, L3430**  
**B : L3830, L4630**

W10149730

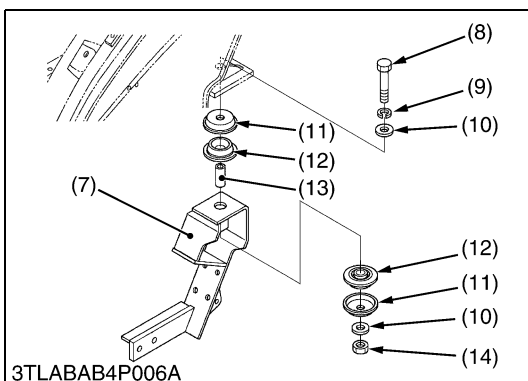
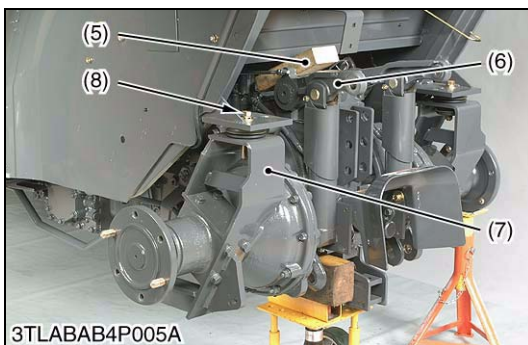

**Rear Wheel and Cabin Mount Screw (Cabin Model)**

1. Place the disassembling stand under the transmission case.
2. Remove the rear wheel mounting screws and nuts.
3. Remove the rear wheels.
4. Remove the top link (1) and lift rod (2).
5. Disconnect the check chain (4) and remove the lower link (3).
6. Place a block of wood (5) between cabin and lift arm (6) to support the cabin.
7. Remove the cabin mount bracket mounting bolt (8) and nut.

**(When reassembling)**

- Be sure to install the washers, plate and mount rubbers, etc. in their original positions.

Tightening torque	Rear wheel mounting screw and nut	215 N-m 22 kgf-m 160 ft-lbs
	Rear wheel mounting stud bolt	98.1 to 112.8 N-m 10.0 to 11.5 kgf-m 72.3 to 83.2 ft-lbs
	Cabin mounting bolt and nut	124 to 147 N-m 13.0 to 15.0 kgf-m 91.0 to 108.0 ft-lbs
	Cabin mount bracket mounting screw	166.7 to 196.1 N-m 17 to 20 kgf-m 123 to 144 ft-lbs

- (1) Top Link
- (2) Lift Rod
- (3) Lower Link
- (4) Check Chain
- (5) Block of Wood
- (6) Lift Arm
- (7) Cabin Mount Bracket
- (8) Bolt (M14 × 90)
- (9) Spring Washer
- (10) Plain Washer
- (11) Plate
- (12) Mount Rubber
- (13) Collar
- (14) Nut

W1015212



### Rear Axle Case

1. Disconnect the brake rod.
2. Disconnect the parking brake rod and parking brake cable (left side only).
3. Place the disassembling stand under the rear axle case.
4. Remove the rear axle mounting screws and nuts.
5. Separate the rear axle case from brake case.

#### (When reassembling)

- Apply liquid gasket (Three Bond 1208D or equivalent) to joint face of the rear axle case and brake case.
- Be sure to check and adjust the parking brake lever free play (see page 5-S4).

Tightening torque	Rear axle case mounting screw and nut	M10 screw	48.1 to 55.9 N·m 4.9 to 5.7 kgf·m 35.4 to 41.2 ft-lbs
		M10 nut (9T) (Except L3130, L3430)	60.8 to 70.5 N·m 6.2 to 7.2 kgf·m 44.9 to 52.1 ft-lbs
		M12 screw (Except L3130, L3430)	77.5 to 90.2 N·m 7.9 to 9.2 kgf·m 57.1 to 66.5 ft-lbs
		Stud bolt	24.5 to 31.4 N·m 2.5 to 3.2 kgf·m 18.1 to 23.1 ft-lbs

W10200480



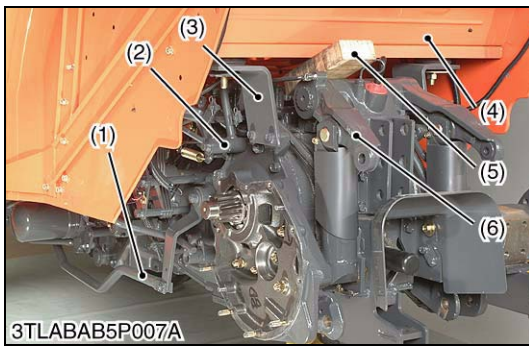

**Brake Case**

1. Disconnect the brake rod (1).
2. Place a block of wood (5) between floor seat (4) and lift arm (6) to support the floor seat. (ROPS model)
3. Place the floor seat mounting bolts and nuts. (ROPS model)
4. Remove the floor seat support (3). (ROPS model)
5. Remove the fulcrum shaft (2) and disconnect the levers. (Left side only)
6. Remove the brake case mounting screws and nuts.
7. Remove the brake case (7).

**(When reassembling)**

- Place the brake discs (10) so that the hole “A” of brake discs should be overlapped 50 % or more.
- Apply liquid gasket (Three Bond 1208D or equivalent) to joint face of the brake case and differential gear case.
- Be sure to apply the liquid gasket to a position.
- Apply grease to the steel ball seats. (Do not grease excessively.)
- Be sure to fix the brake cam (13) and cam plate (9).
- Before installing the brake case to the transmission case, install the cam plate (9) to the transmission case.

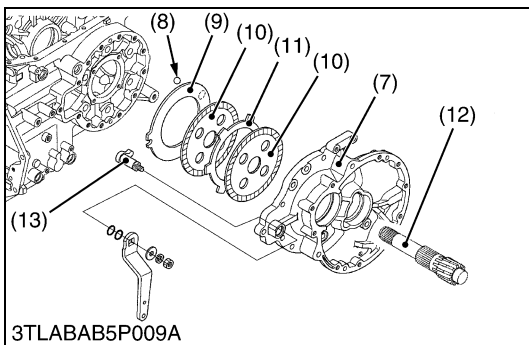
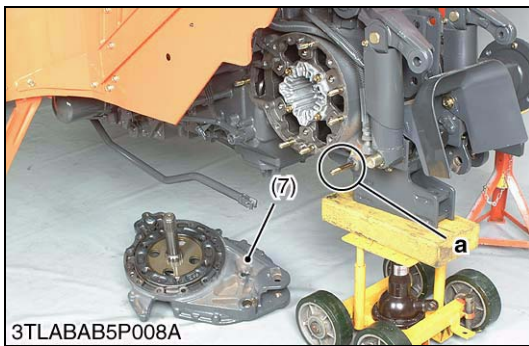

Tightening torque	Brake case mounting screw and nut	77.5 to 90.2 N-m 7.9 to 9.2 kgf-m 57.1 to 66.5 ft-lbs
	Floor seat mounting bolt and nut	196 to 225 N-m 20 to 23 kgf-m 145 to 166 ft-lbs
	Brake case mounting stud bolt	38.2 to 45.1 N-m 3.9 to 4.6 kgf-m 28.2 to 33.3 ft-lbs

- |                        |                  |
|------------------------|------------------|
| (1) Brake Rod          | (8) Steel Ball   |
| (2) Fulcrum Shaft      | (9) Cam Plate    |
| (3) Floor Seat Support | (10) Brake Disc  |
| (4) Floor Seat         | (11) Plate       |
| (5) Block of Wood      | (12) Brake Shaft |
| (6) Lift Arm           | (13) Brake Cam   |
| (7) Brake Case         |                  |

W1015647

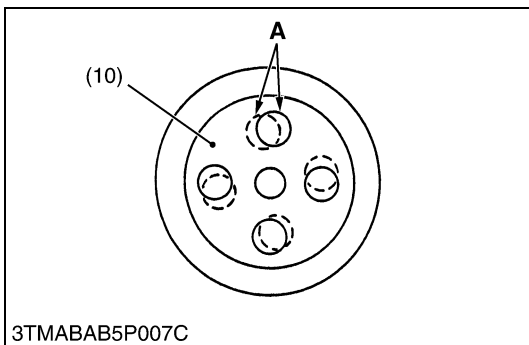

**Brake Cam and Brake Cam Lever**

1. Remove the brake cam mounting nut and remove the brake cam (2) and brake cam lever (4).

**(When reassembling)**

- Apply grease to the O-ring (3) and take care not damage the O-ring.

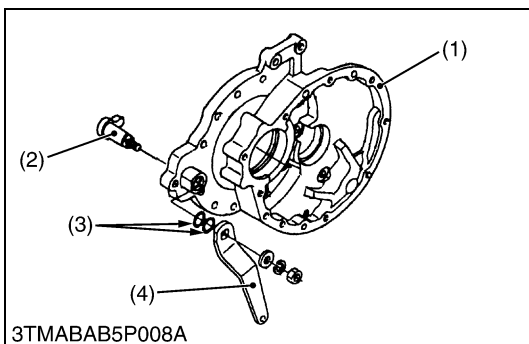

Tightening torque	Brake cam lever mounting nut	62.8 to 72.5 N-m 6.4 to 7.4 kgf-m 46.3 to 53.5 ft-lbs
-------------------	------------------------------	---

- |                |                     |
|----------------|---------------------|
| (1) Brake Case | (3) O-ring          |
| (2) Brake Cam  | (4) Brake Cam Lever |

W1014346

**(2) Servicing**

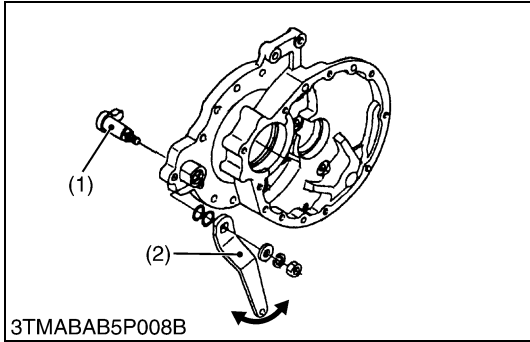

**Brake Cam Lever Movement**

1. Assemble the brake cam (1) and brake cam lever (2).
2. Move the brake cam lever by hand to check the movement.
3. If the movement is heavy, refine the brake cam lever or brake case with sandpaper.

(1) Brake Cam

(2) Brake Cam Lever

W10144750

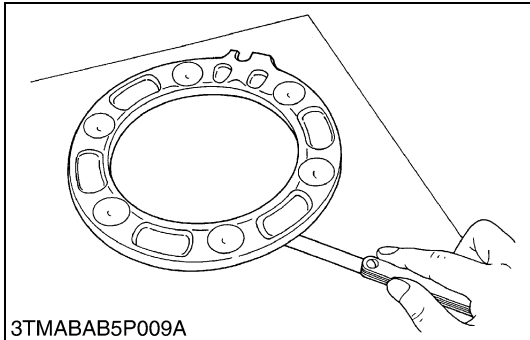

**Cam Plate Flatness**

1. Place the cam plate on the surface plate.
2. Measure the flatness of cam plate with a feeler gauge at four points on a diagonal line.
3. If the measurement exceed the allowable limit, replace it.

Cam Plate Flatness	Allowable limit	0.3 mm 0.012 in.
--------------------	-----------------	---------------------

W10145650

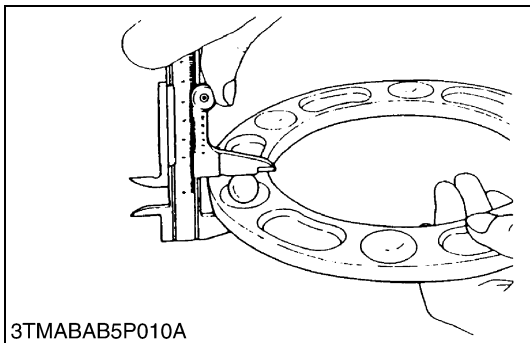

**Height of Cam Plate and Ball**

1. Measure the dimension of the cam plate with the ball installed.
2. If the measurement is less than the allowable limit, replace the cam plate and balls.
3. Inspect the ball holes of cam plate for uneven wear. If the uneven wear is found, replace it.

Height of cam plate and ball	Factory spec.	20.9 to 21.1 mm 0.823 to 0.831 in.
	Allowable limit	20.5 mm 0.807 in.

W10147220

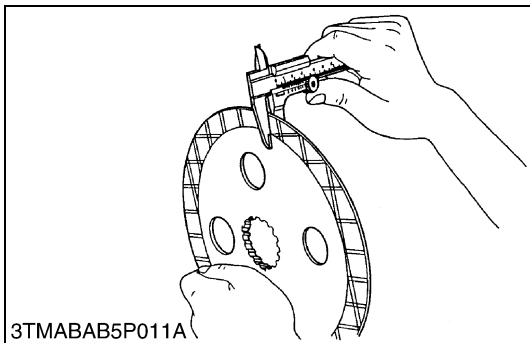

**Brake Disc Wear**

1. Measure the brake disc thickness with vernier calipers.
2. If the measurement is less than the allowable limit, replace it.

Brake disc thickness	Factory spec.	4.6 to 4.8 mm 0.181 to 0.189 in.
	Allowable limit	4.2 mm 0.165 in.

W10148530

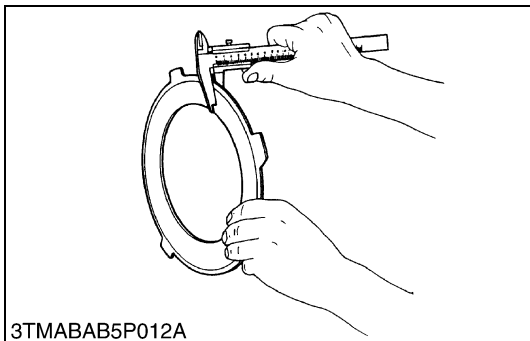

**Plate Wear**

1. Measure the plate thickness with vernier calipers.
2. If the measurement is less than the allowable limit, replace it.

Plate thickness	Factory spec.	2.54 to 2.66 mm 0.1000 to 0.1047 in.
	Allowable limit	2.1 mm 0.083 in.

W10149690



# 6 FRONT AXLE

# MECHANISM

## CONTENTS

1. STRUCTURE .....	6-M1
--------------------	------

# 1. STRUCTURE

(for L3130, L3430, L3830 and L4630)

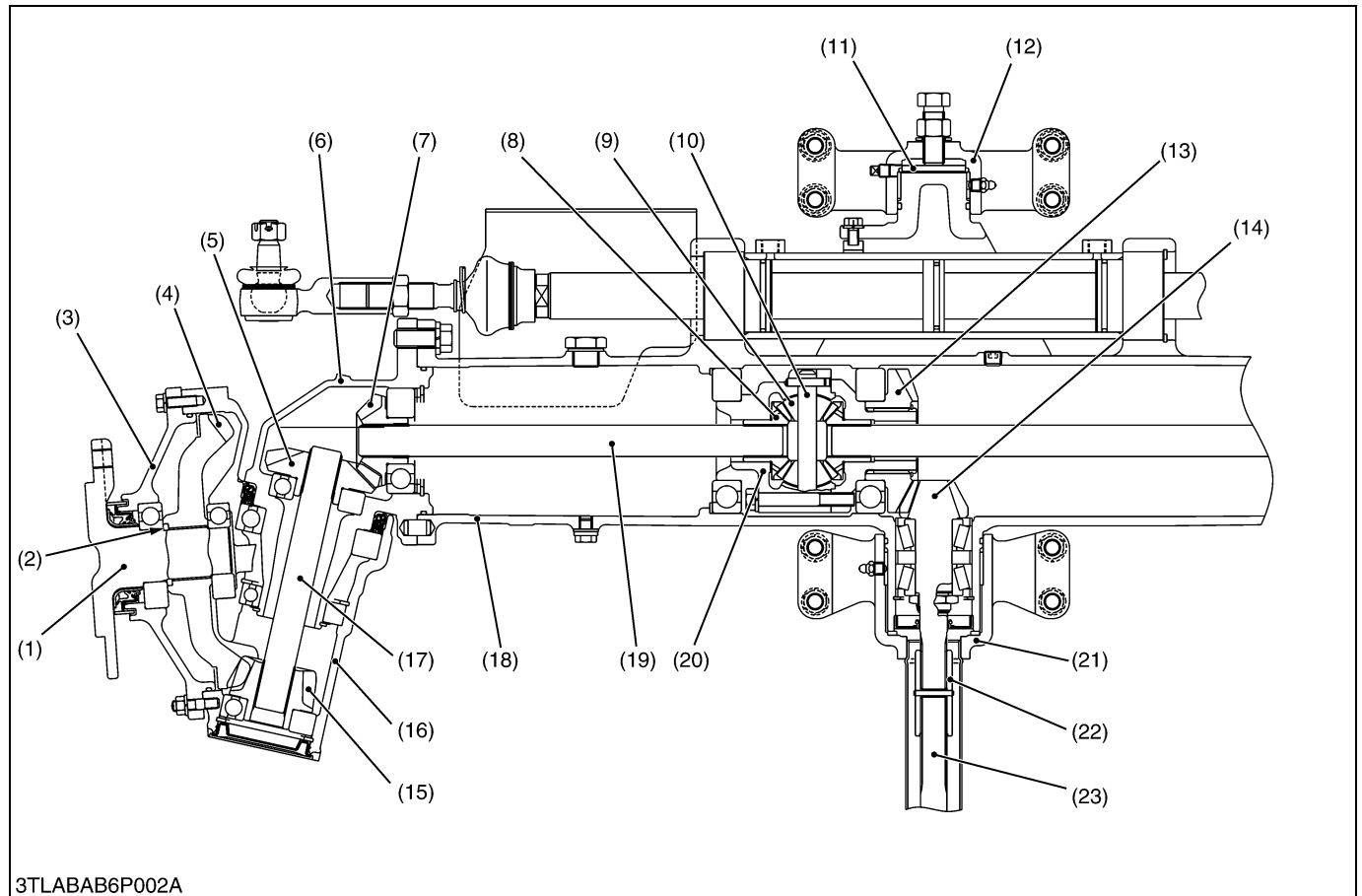

3TLABAB6P002A

- |                     |                                |                                |                               |
|---------------------|--------------------------------|--------------------------------|-------------------------------|
| (1) Axle            | (7) Bevel Gear                 | (13) Spiral Bevel Gear         | (19) Differential Yoke Shaft  |
| (2) Collar          | (8) Differential Side Gear     | (14) Spiral Bevel Pinion Shaft | (20) Differential Case        |
| (3) Axle Flange     | (9) Differential Pinion        | (15) Bevel Gear                | (21) Front Axle Bracket, Rear |
| (4) Bevel Gear      | (10) Pinion Shaft              | (16) Front Gear Case           | (22) Coupling                 |
| (5) Bevel Gear      | (11) Collar                    | (17) Bevel Gear Shaft          | (23) Propeller Shaft          |
| (6) Bevel Gear Case | (12) Front Axle Bracket, Front | (18) Front Axle Case           |                               |

The front axle of the 4WD is constructed as shown above. Power is transmitted from the transmission through the propeller shaft (23) and to the bevel pinion shaft (14), then to the spiral bevel gear (13) after that to the differential gear.

The power through the differential is transmitted to the differential yoke shaft (19), and to the bevel gear shaft (17) in the bevel gear case (6).

The revolution is greatly reduced by the bevel gears (15), (4), then the power is transmitted to the axle (1).

The differential system allows each wheel to rotate at a different speed to make turning easier.

(for L5030)

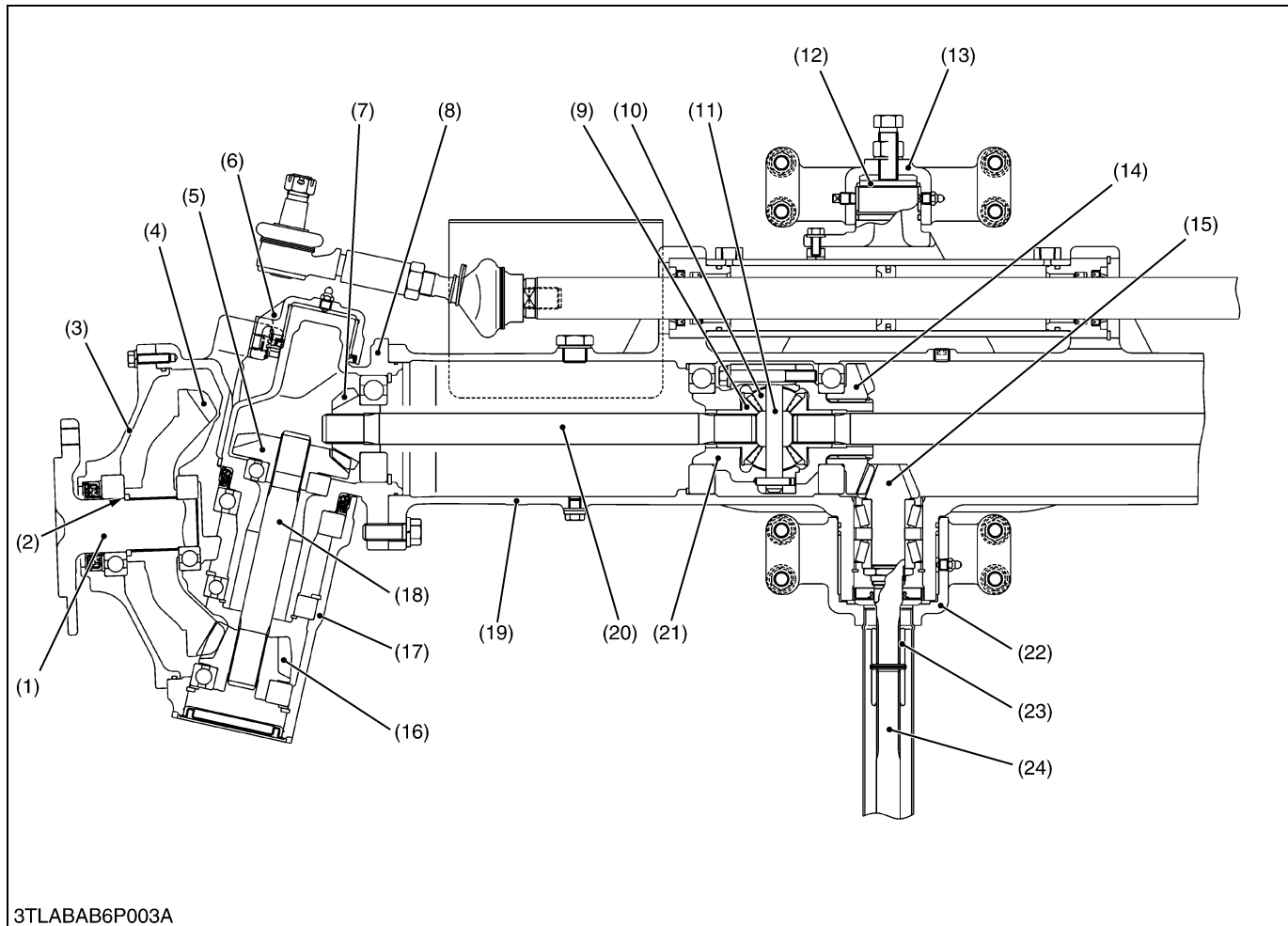

- |                       |                            |                                |                               |
|-----------------------|----------------------------|--------------------------------|-------------------------------|
| (1) Axle              | (7) Bevel Gear             | (13) Front Axle Bracket, Front | (19) Front Axle Case          |
| (2) Collar            | (8) Bevel Gear Case        | (14) Spiral Bevel Gear         | (20) Differential Yoke Shaft  |
| (3) Axle Flange       | (9) Differential Side Gear | (15) Spiral Bevel Pinion Shaft | (21) Differential Case        |
| (4) Bevel Gear        | (10) Differential Pinion   | (16) Bevel Gear                | (22) Front Axle Bracket, Rear |
| (5) Bevel Gear        | (11) Pinion Shaft          | (17) Front Gear Case           | (23) Coupling                 |
| (6) Axle Case Support | (12) Collar                | (18) Bevel Gear Shaft          | (24) Propeller Shaft          |

# SERVICING

## CONTENTS

1. TROUBLESHOOTING .....	6-S1
2. SERVICING SPECIFICATIONS .....	6-S2
3. TIGHTENING TORQUES .....	6-S4
4. CHECKING, DISASSEMBLING AND SERVICING.....	6-S5
[1] CHECKING AND ADJUSTING .....	6-S5
[2] DISASSEMBLING AND ASSEMBLING.....	6-S7
(1) Separating Front Axle Assembly.....	6-S7
(2) Disassembling Front Axle .....	6-S8
[3] SERVICING .....	6-S15

# 1. TROUBLESHOOTING

Symptom	Probable Cause	Solution	Reference Page
<b>Front Wheels Wander to Right or Left</b>	<ul style="list-style-type: none"> <li>• Tire pressure uneven</li> <li>• Improper toe-in adjustment (improper alignment)</li> <li>• Clearance between front axle case boss and front axle bracket (front, rear) bushing excessive</li> <li>• Front axle rocking force too small</li> <li>• Front wheel sway excessive</li> <li>• Tie-rod end loose</li> <li>• Air sucked in power steering circuit</li> </ul>	Adjust Adjust  Replace  Adjust Replace Tighten Bleed	G-55 6-S5  6-S19  6-S6 6-S5 6-S9 7-S12
<b>Front Wheels Can Not Be Driven</b>	<ul style="list-style-type: none"> <li>• Propeller shaft broken</li> <li>• Front wheel drive gears in transmission broken</li> <li>• Front differential gear broken</li> <li>• Shift fork broken</li> <li>• Coupling displaced</li> </ul>	Replace Replace  Replace Replace Reassemble	6-S7 3-S38, S75, S113 6-S14 – 6-S7
<b>Noise</b>	<ul style="list-style-type: none"> <li>• Gear backlash excessive</li> <li>• Oil insufficient</li> <li>• Bearings damaged or broken</li> <li>• Gears damaged or broken</li> <li>• Spiral bevel pinion shaft turn force improper</li> </ul>	Adjust or replace Replenish Replace Replace Adjust	6-S15 to 18 G-7, 8 – – 6-S16

W10143220



## 2. SERVICING SPECIFICATIONS

Item		Factory Specification	Allowable Limit
Front Wheel Alignment	Toe-in	2 to 8 mm 0.08 to 0.32 in.	–
Front Wheel	Steering Angle (L3130, L3430, L3830 and L4630)	0.925 to 0.960 rad 53 to 55 °	–
	(L5030)	0.733 to 0.768 rad 42 to 44 °	–
	Axial Sway	5.0 mm 0.196 in.	–
	Radial Sway	5.0 mm 0.197 in.	–
(for L3130, L3430, L3830 and L4630) Differential Case, Differential Case Cover to Differential Side Gear	Clearance	0.050 to 0.151 mm 0.00197 to 0.00597 in.	0.20 mm 0.0079 in.
	Differential Case	I.D. 32.000 to 32.062 mm 1.25984 to 1.26228 in.	–
	Differential Case Cover	I.D. 32.000 to 32.025 mm 1.25984 to 1.26083 in.	–
	Differential Side Gear	O.D. 31.911 to 31.950 mm 1.25634 to 1.25789 in.	–
(for L5030) Differential Case, Differential Case Cover to Differential Side Gear	Clearance	0.050 to 0.114 mm 0.00197 to 0.00449 in.	0.20 mm 0.0079 in.
	Differential Case	I.D. 32.000 to 32.025 mm 1.25984 to 1.26083 in.	–
	Differential Case Cover	I.D. 32.000 to 32.025 mm 1.25984 to 1.26083 in.	–
	Differential Side Gear	O.D. 31.911 to 31.950 mm 1.25634 to 1.25789 in.	–
Pinion Shaft to Differential Pinion	Clearance	0.064 to 0.100 mm 0.00252 to 0.00394 in.	0.25 mm 0.0096 in.
	Pinion Shaft	O.D. 13.950 to 13.968 mm 0.54921 to 0.54992 in.	–
	Differential Pinion	I.D. 14.032 to 14.050 mm 0.55244 to 0.55315 in.	–
Differential Pinion to Differential Side Gear	Backlash	0.2 to 0.3 mm 0.008 to 0.012 in.	0.4 mm 0.016 in.
Spiral Bevel Pinion Shaft	Turning Torque	0.98 to 1.18 N·m 0.10 to 0.12 kgf·m 0.72 to 0.87 ft-lbs	–

W10109890

**(Continued)**

Item		Factory Specification	Allowable Limit
(for L3130, L3430, L3830 and L4630) Spiral Bevel Pinion Shaft to Spiral Bevel Gear	Backlash	0.1 to 0.3 mm 0.004 to 0.012 in.	–
(for L5030) Spiral Bevel Pinion Shaft to Spiral Bevel Gear	Backlash	0.2 to 0.3 mm 0.008 to 0.012 in.	–
Bevel Gear to Bevel Gear	Backlash	0.15 to 0.35 mm 0.006 to 0.014 in.	0.6 mm 0.024 in.
Front Axle Case Boss (Front) to Bracket Bushing	Clearance	0.120 to 0.275 mm 0.00472 to 0.01083 in.	0.50 mm 0.19685 in.
Front Axle Case Boss (Front)	O.D.	49.950 to 49.975 mm 1.96653 to 1.96752 in.	–
Bushings	I.D.	50.095 to 50.225 mm 1.97224 to 1.97736 in.	–
(for L3130, L3430, L3830 and L4630) Front Axle Case Boss (Rear) to Bracket Bushing	Clearance	0.100 to 0.292 mm 0.00394 to 0.01150 in.	1.0 mm 0.03937 in.
Front Axle Case Boss (Rear)	O.D.	69.970 to 70.000 mm 2.75472 to 2.75590 in.	–
Bushings	I.D.	70.100 to 70.262 mm 2.75984 to 2.76622 in.	–
(for L5030) Front Axle Case Boss (Rear) to Bracket Bushing	Clearance	0.025 to 0.195 mm 0.00098 to 0.00768 in.	0.5 mm 0.19685 in.
Front Axle Case Boss (Rear)	O.D.	80.000 to 80.035 mm 3.14961 to 3.15098 in.	–
Bushings	I.D.	80.060 to 80.195 mm 3.15197 to 3.15728 in.	–
(for L5030) Bevel Gear Case Boss to Front Axle Support Bushing	Clearance	0.080 to 0.232 mm 0.00315 to 0.00913 in.	1.0 mm 0.03937 in.
Bevel Gear Case Boss	O.D.	54.970 to 55.000 mm 2.16417 to 2.16535 in.	–
Front Axle Support Bushing	I.D.	55.080 to 55.202 mm 2.16850 to 2.17331 in.	–

W10138740

### 3. TIGHTENING TORQUES

Tightening torques of screws, bolts and nuts on the table below are especially specified.  
(For general use screws, bolts and nuts : See page G-10.)

Item	N-m	kgf-m	ft-lbs
Tie-rod lock nut	166.7 to 196.1	17.0 to 20.0	123 to 145
Front axle adjusting screw	19.6 to 29.4	2.0 to 3.0	14.5 to 21.7
Lock nut (L3130, L3430, L3830, L4630)	39.2 to 58.8	4.0 to 6.0	28.9 to 43.4
(L5030)	58.8 to 98.1	6.0 to 10.0	43.4 to 72.3
Power steering hose retaining nut	24.5 to 29.4	2.5 to 3.0	18.1 to 21.7
Cylinder cover mounting screw	60.8 to 70.6	6.2 to 7.2	44.8 to 52.1
Front wheel mounting nut	137	14.0	100
Front bracket and rear bracket mounting screw and nut	77.5 to 90.1	7.9 to 9.2	57.2 to 66.5
Tie-rod end nut (L3130, L3430, L3830, L4630)	39.2 to 45.1	4.0 to 4.6	28.9 to 33.3
(L5030)	156.9 to 176.5	16.0 to 18.0	115.7 to 130.2
Bevel gear case mounting screw			
(L3130, L3430, L3830, L4630)	123 to 147	12.6 to 15.0	91.1 to 108.5
(L5030)	166.7 to 196.1	17.0 to 20.0	123 to 145
Axle flange mounting screw and nut			
(L3130, L3430, L3830, L4630)	23.6 to 27.5	2.4 to 2.8	17.4 to 20.3
(L5030)	29.4 to 34.3	3.0 to 3.5	21.7 to 25.3
Axle case support mounting screw (L5030)	127 to 142	13.0 to 14.5	94.6 to 104.9
Tie-rod joint to steering cylinder	166.7 to 196.1	17.0 to 20.0	122.9 to 144.6
Differential case cover mounting screw			
(L3130, L3430, L3830, L4630)	48.0 to 58.8	4.9 to 6.0	35.4 to 43.4
(L5030)	60.8 to 70.6	6.2 to 7.2	44.8 to 52.1

W10117570

## 4. CHECKING, DISASSEMBLING AND SERVICING

### [1] CHECKING AND ADJUSTING

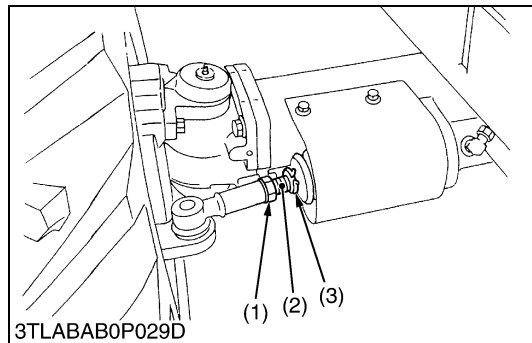
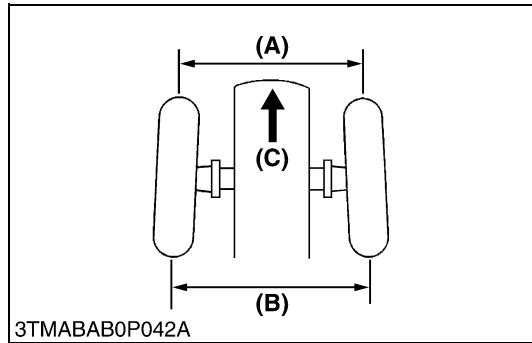

#### Toe-in

1. Park the tractor on the flat place.
2. Inflate the tires to the specified pressure.
3. Turn steering wheel so front wheels are in the straight ahead position.
4. Lower the implement, lock the parking brake and stop the engine.
5. Measure distance between tire beads at front of tire, hub height.
6. Measure distance between tire beads at rear of tire, hub height.
7. Front distance should be 2 to 8 mm (0.08 to 0.32 in.) less than rear distance.
8. If the measurement is not within the factory specifications, adjust by changing the tie-rod length.

Toe-in (B - A)	Factory spec.	2 to 8 mm 0.08 to 0.32 in.
----------------	---------------	-------------------------------

#### ■ **Adjusting**

1. Detach the snap ring (3).
2. Loosen the tie-rod lock nut (1).
3. Turn the tie-rod joint (2) to adjust the rod length until the proper toe-in measurement is obtained.
4. Retighten the tie-rod lock nut (1).
5. Attach the snap ring (3).

Tightening torque	Tie-rod lock nut	166.7 to 196.1 N·m 17.0 to 20.0 kgf·m 123 to 145 ft-lbs
-------------------	------------------	---

#### ■ **IMPORTANT**

- **A right and left tie-rod joint is adjusted to the same length.**

- |                   |                                      |
|-------------------|--------------------------------------|
| (1) Tie-rod Nut   | (A) Wheel to Wheel Distance at front |
| (2) Tie-rod Joint | (B) Wheel to Wheel Distance at rear  |
| (3) Snap Ring     | (C) Front                            |

W10213280

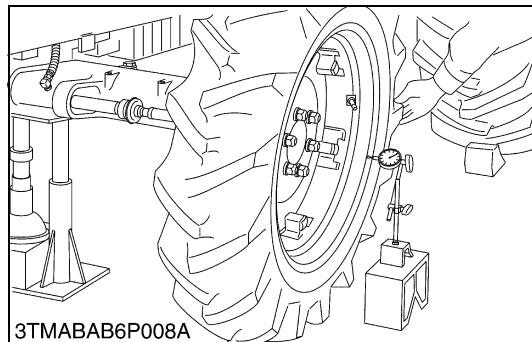

#### Axial Sway of Front Wheel

1. Jack up the front side of tractor.
2. Set a dial gauge on the outside of rim.
3. Turn the wheel slowly and read the runout of rim.
4. If the measurement exceeds the factory specifications, check the bearing, rim and front wheel hub.

Axial sway of front wheel	Factory spec.	Less than 5.0 mm 0.197 in.
---------------------------	---------------	-------------------------------

W10120920

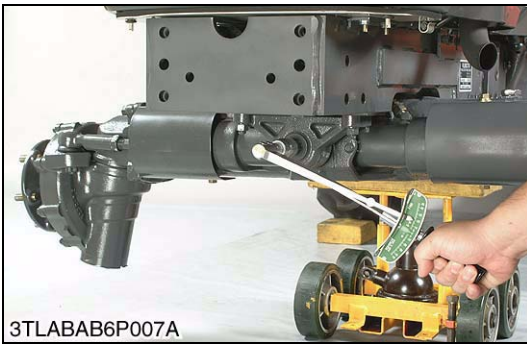

**Adjusting Front Axle Pivot**

1. Jack up the tractor body, then loosen the lock nut (2).
2. Measure the adjusting screw tightening torque.
3. If tightening torque is not within the factory specifications, adjust the adjusting screw (1).
4. After adjustment, tighten the lock nut firmly.

**(When reassembling)**

Tightening torque	Front axle adjusting screw		19.6 to 29.4 N·m 2.0 to 3.0 kgf·m 14.5 to 21.7 ft-lbs
	Lock nut	L3130 L3430 L3830 L4630	39.2 to 58.8 N·m 4.0 to 6.0 kgf·m 28.9 to 43.4 ft-lbs
		L5030	58.8 to 98.1 N·m 6.0 to 10.0 kgf·m 43.4 to 72.3 ft-lbs

(1) Adjusting Screw

(2) Lock Nut

W10122030

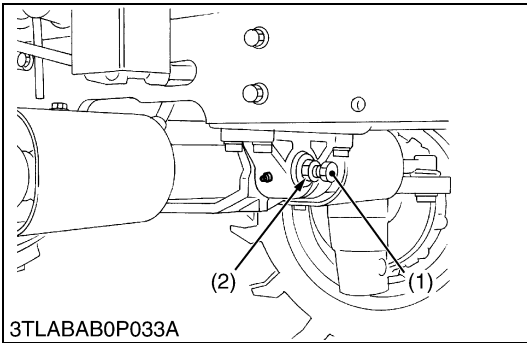

**Front Wheel Steering Angle (for L5030)**

1. Inflate the tires to the specified pressure.
2. Steer the wheels to the extreme right until the front gear case (1) contacts with the bevel gear case (2) at right hand side of the front axle.
3. If the front gear case (1) can not be contacted with the bevel gear case (2), shorten the length of stopper (3).
4. Keeping the front gear case (1) contact with the bevel gear case (2), make a specified clearance (A) as shown in the lower table.
5. After adjustment, secure the stopper with the lock nut (4).
6. For adjusting the left steering angle, perform the same procedure as mentioned in right steering angle.

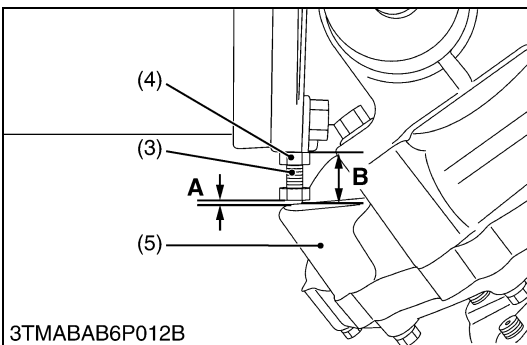
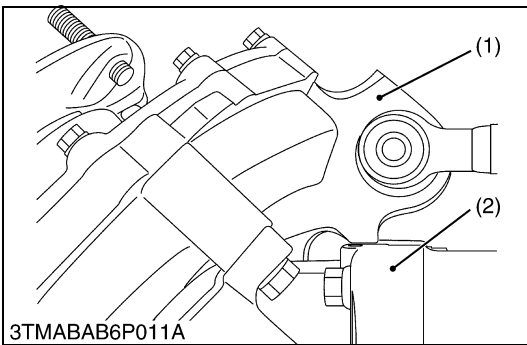

Clearance (A) between bevel gear case and stopper	Factory spec.	1.0 to 3.0 mm 0.04 to 0.12 in.
---	---------------	-----------------------------------

**(Reference)**

Clearance B	Reference	34 mm 1.3 in.
-------------	-----------	------------------

- (1) Front Gear Case
- (2) Bevel Gear Case
- (3) Stopper
- (4) Lock Nut

(5) Front Gear Case

**A : Clearance**

**B : Clearance**

W10126440

## [2] DISASSEMBLING AND ASSEMBLING

### (1) Separating Front Axle Assembly

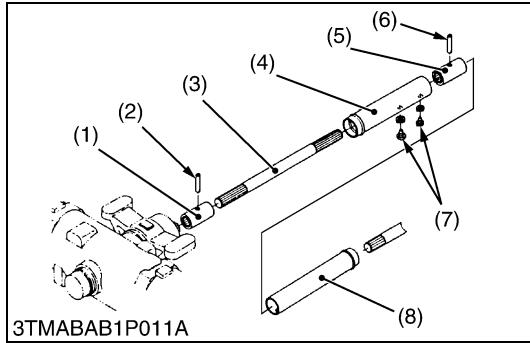

#### Propeller Shaft

1. Slide the propeller shaft cover (4) and (8) after removing the screws (7).
2. Tap out the spring pins (2), (6) and slide the couplings (1), (5) and then remove the propeller shaft with covers (4), (8).

#### (When reassembling)

- Apply grease to the splines of propeller shaft 1 (3).

- |                           |                           |
|---------------------------|---------------------------|
| (1) Coupling              | (5) Coupling              |
| (2) Spring Pin            | (6) Spring Pin            |
| (3) Propeller Shaft 1     | (7) Screws                |
| (4) Propeller Shaft Cover | (8) Propeller Shaft Cover |

W1035934

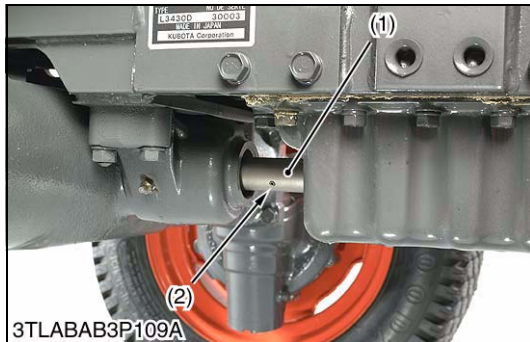

#### Power Steering Hoses

1. Disconnect the power steering hoses (1), (2) from steering cylinder.
2. Remove the cylinder cover.

#### (When reassembling)

Tightening torque	Power steering hose retaining nut	24.5 to 29.4 N·m 2.5 to 3.0 kgf·m 18.1 to 21.7 ft·lbs
	Cylinder cover mounting screw	60.8 to 70.6 N·m 6.2 to 7.2 kgf·m 44.8 to 52.1 ft·lbs

- (1) Power Steering Hose, RH (with Red Tape) (3) Cylinder Cover  
 (2) Power Steering Hose, LH (with Blue Tape)

W10225690





3TLABAB6P009A

**Front Wheel and Front Axle Assembly**

1. Check the front axle and engine are securely mounted on the disassembly stand.
2. Loosen the front wheel mounting nuts.
3. Lift the front axle and remove the front wheels.
4. Remove the bracket (front) mounting screws and nuts.
5. Remove the bracket (rear) mounting screws and nuts.
6. Separate the front axle from front axle bracket.

**(When reassembling)**

■ **IMPORTANT**

- **Be sure to adjust the front axle rocking force.**  
(See page 6-S6.)

Tightening torque	Front wheel mounting nut	137 N·m 14.0 kgf·m 100 ft·lbs
	Bracket mounting screw and nut	77.5 to 90.1 N·m 7.9 to 9.2 kgf·m 57.2 to 66.5 ft·lbs

W10136920

**(2) Disassembling Front Axle**

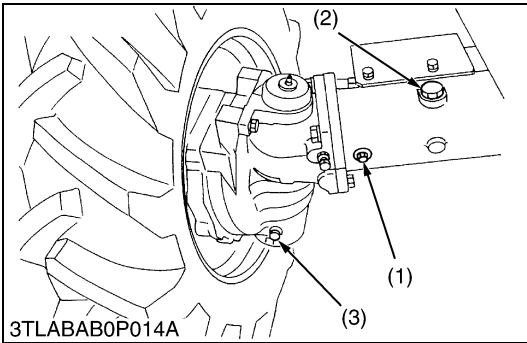

3TLABAB0P014A

**Draining Front Axle Case Oil**

1. Place oil pans underneath the front axle case.
2. Remove the drain plug (3) both sides and filling port plug (2) to drain the oil.
3. After draining, reinstall the drain plugs (3) and filling port plug (2).

**(When reassembling)**

- Remove the filling port plug (2) and right and left check plugs (1).
- Fill with the new oil.
- After filling, reinstall the filling port plug (2).

Capacity	Front axle case oil	L3130 L3430 L3830 L4630	6.5 L 6.9 U.S.qts 5.7 Imp.qts
		L5030	6.0 L 6.3 U.S.qts 5.3 Imp.qts

■ **IMPORTANT**

- **Use KUBOTA SUPER UDT fluid or SAE80, 90 gear oil.**  
Refer to “LUBRICANTS, FUEL AND COOLANT”. (See page G-7, 8.)

- (1) Check Plug (3) Drain Plug  
(2) Filling Port Plug

W10128890

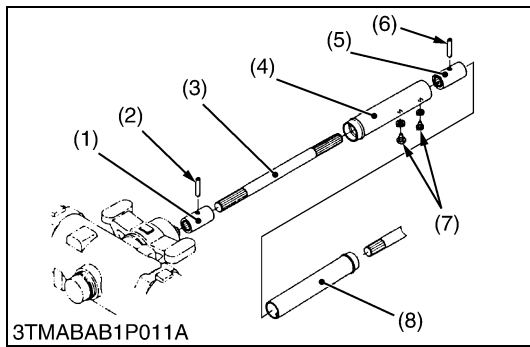

3TMABAB1P011A

**Propeller Shaft**

1. Slide the propeller shaft cover (4) and (8) after removing the screws (7).
2. Tap out the spring pins (2), (6) and slide the couplings (1), (5) and then remove the propeller shaft with covers (4), (8).

**(When reassembling)**

- Apply grease to the splines of propeller shaft 1 (3).
- |                           |                           |
|---------------------------|---------------------------|
| (1) Coupling              | (5) Coupling              |
| (2) Spring Pin            | (6) Spring Pin            |
| (3) Propeller Shaft 1     | (7) Screws                |
| (4) Propeller Shaft Cover | (8) Propeller Shaft Cover |

W1048514

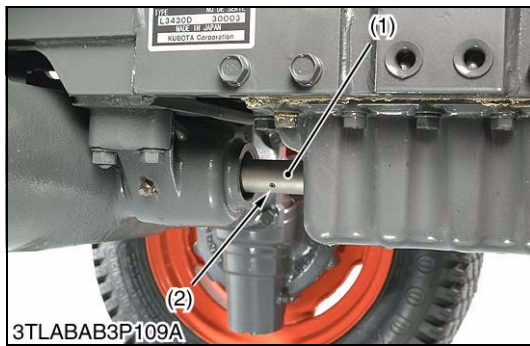

3TLABAB3P109A

**Tie-rods**

1. Pull out the cotter pin and remove the tie-rod end slotted nuts.
2. Remove the tie-rod with a tie-rod end lifter (Code No. 07909-39051).

**(When reassembling)**

- After tightening the tie-rod end nut to the specified torques, install a cotter pin as shown in the figure left.

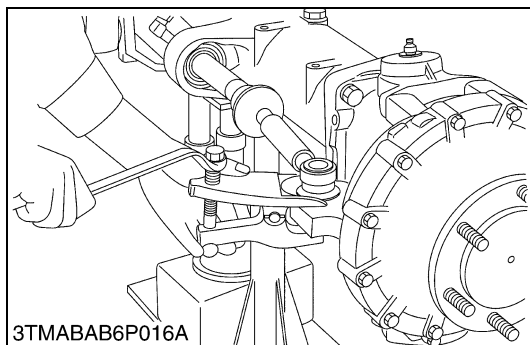

3TMABAB6P016A

Tightening torque	Tie-rod end nut	L3130	39.2 to 45.1 N·m
		L3430	4.0 to 4.6 kgf·m
		L3830	28.9 to 33.3 ft·lbs
		L4630	
		L5030	156.9 to 176.5 N·m
			16.0 to 18.0 kgf·m
			115.7 to 130.2 ft·lbs

W10145200

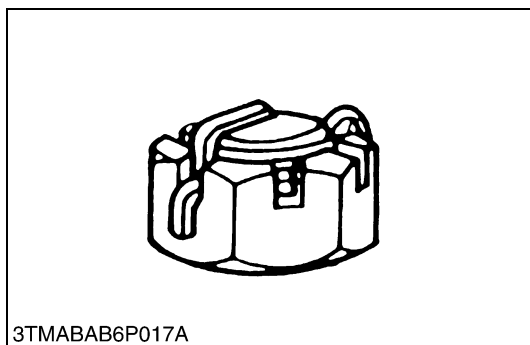

3TMABAB6P017A

**Bevel Gear Case and Front Gear Case (for L3130, L3430, L3830 and L4630)**

1. Remove the bevel gear case mounting screws.
2. Remove the bevel gear case (2) and front gear case (3) as a unit from the front axle case (1).

**(When reassembling)**

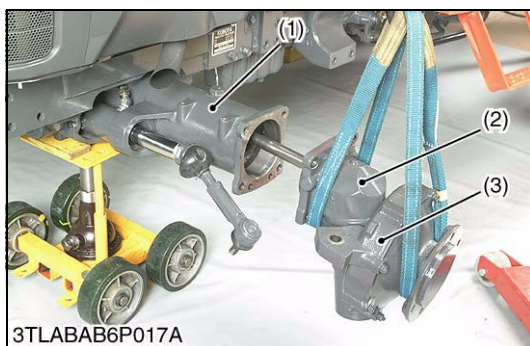

3TLABAB6P017A

Tightening torque	Bevel gear case mounting screw	123 to 147 N·m 12.6 to 15.0 kgf·m 91.1 to 108.5 ft·lbs
-------------------	--------------------------------	--

- |                     |                     |
|---------------------|---------------------|
| (1) Front Axle Case | (3) Front Gear Case |
| (2) Bevel Gear Case |                     |

W10227940

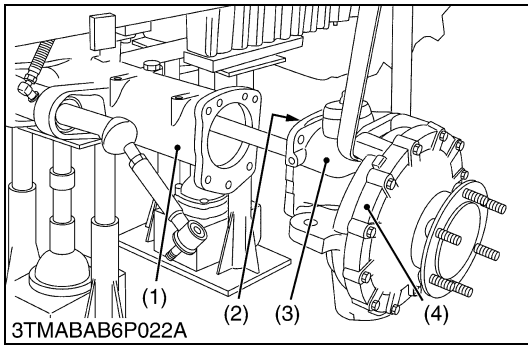

### **Bevel Gear Case and Front Gear Case (for L5030)**

1. Remove the bevel gear case mounting screws.
2. Remove the bevel gear case (3) and front gear case (4) as a unit from the front axle case (1).

#### **(When reassembling)**

- Apply grease to the O-ring (2) and take care not to damage it.
- Do not interchange right and left bevel gear case assemblies.

Tightening torque	Bevel gear case mounting screw	166.7 to 196.1 N·m 17.0 to 20.0 kgf·m 123 to 145 ft·lbs
-------------------	--------------------------------	---

- (1) Front Axle Case  
(2) O-ring

- (3) Bevel Gear Case  
(4) Front Gear Case

W10155120

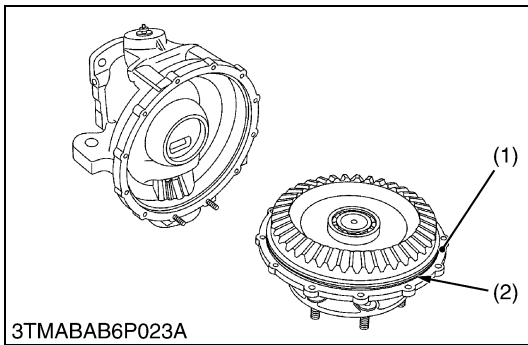

### **Axle Flange and Front Gear Case**

1. Remove the axle flange mounting screws.
2. Remove the axle flange (1).

#### **(When reassembling)**

- Apply grease to the O-ring (2) of axle flange.
- Tighten the axle flange mounting screws and nuts diagonally in several steps.

Tightening torque	Axle flange mounting screw and nut	L3130 L3430 L3830 L4630	23.6 to 27.5 N·m 2.4 to 2.8 kgf·m 17.34 to 20.3 ft·lbs
		L5030	29.4 to 34.3 N·m 3.0 to 3.5 kgf·m 21.7 to 25.3 ft·lbs

- (1) Axle Flange

- (2) O-ring

W10156660

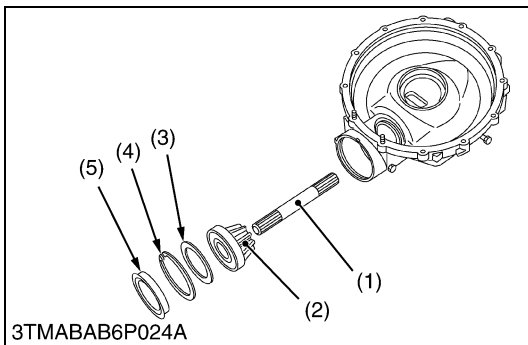

### **Bevel Gear and Bevel Gear Shaft**

1. Remove the plug (5).
2. Remove the internal snap ring (4) and shim (3).
3. Tap out the bevel gear (2) with ball bearing.
4. Draw out the bevel gear shaft (1).

- (1) Bevel Gear Shaft  
(2) Bevel Gear  
(3) Shim

- (4) Internal Snap Ring  
(5) Plug

W10159240

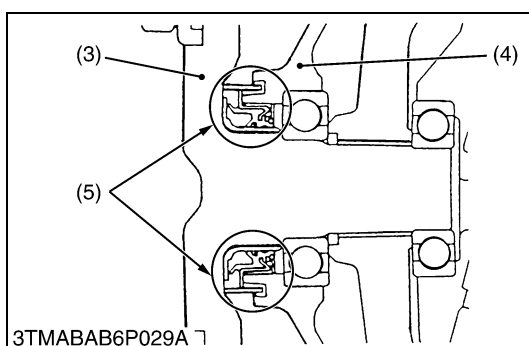
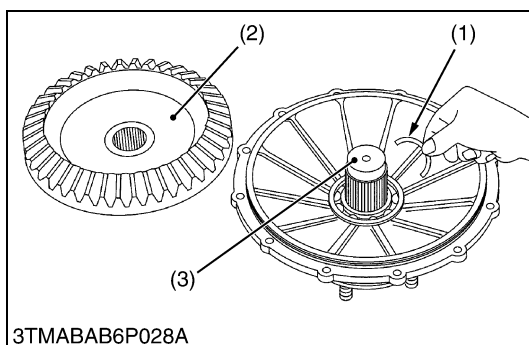
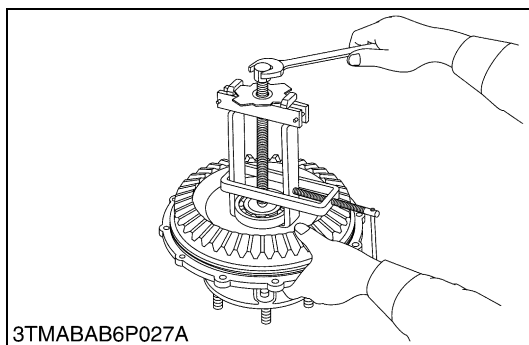
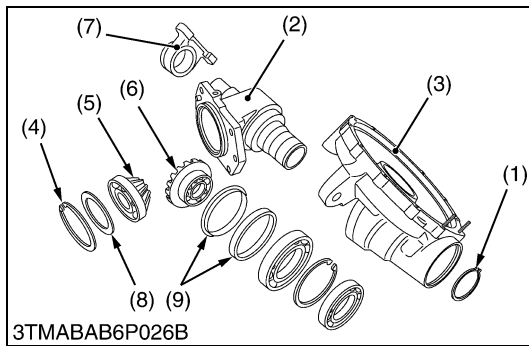
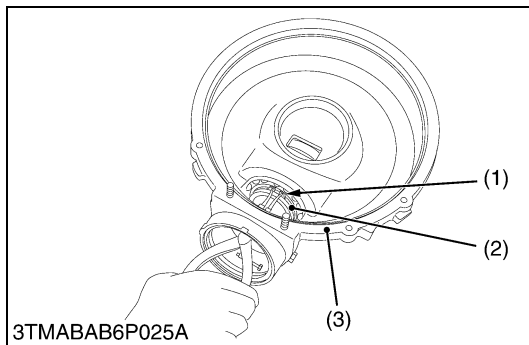

### Bevel Gear Case and Gears

1. Remove the axle case support (7). (L5030 only)
2. Remove the external snap ring (1).
3. Tap the bevel gear case (2) and separate it from the front gear case (3).
4. Remove the internal snap ring (4).
5. Take out the bevel gears (5), (6) with ball bearings, and shims (8).

#### (When reassembling)

- Install the shims (8) to their original position.
- Install the oil seal (9) of bevel gear case, noting its direction.

Tightening torque	Axle case support mounting screw	127 to 142 N·m 13.0 to 14.5 kgf·m 94.0 to 104.9 ft·lbs
-------------------	----------------------------------	--

- |                        |                       |
|------------------------|-----------------------|
| (1) External Snap Ring | (6) Bevel Gear        |
| (2) Bevel Gear Case    | (7) Axle Case Support |
| (3) Front Gear Case    | (8) Shim              |
| (4) Internal Snap Ring | (9) Oil Seal          |
| (5) Bevel Gear         |                       |

W10160540

### Axle

1. Remove the bearing with a special use puller set (Code No. 07916-09032).
2. Take out the bevel gear (2).
3. Take out the collar (1).
4. Tap out the axle (3).

#### (When reassembling)

- Install the oil seal (5) of axle flange (4), noting its direction as shown in the figure below.

- |                |                 |
|----------------|-----------------|
| (1) Collar     | (4) Axle Flange |
| (2) Bevel Gear | (5) Oil Seal    |
| (3) Axle       |                 |

W10163910

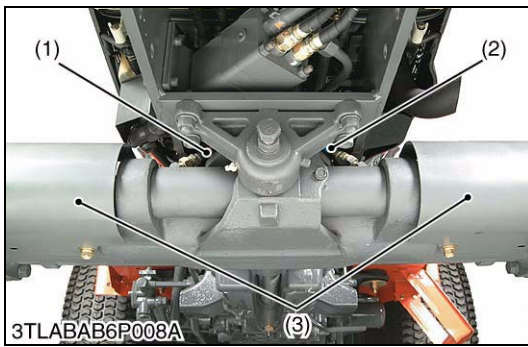

**Power Steering Hoses**

1. Disconnect the power steering hoses (1), (2) from steering cylinder.
2. Remove the cylinder cover.

**(When reassembling)**

Tightening torque	Power steering hose retaining nut	24.5 to 29.4 N·m 2.5 to 3.0 kgf·m 18.1 to 21.7 ft-lbs
	Cylinder cover mounting screw	60.8 to 70.6 N·m 6.2 to 7.2 kgf·m 44.8 to 52.1 ft-lbs

- (1) Power Steering Hose, RH (with Red Tape)
- (2) Power Steering Hose, LH (with Blue Tape)
- (3) Cylinder Cover

W10517600

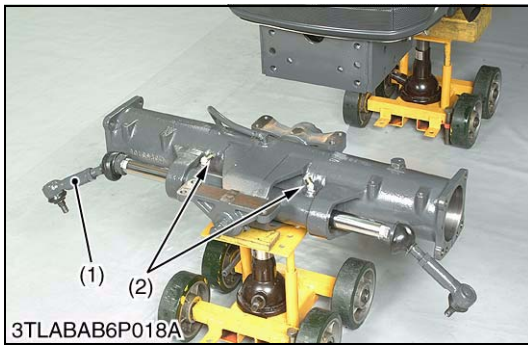

**Steering Cylinder**

1. Support the engine and front axle case by disassembling stand.
2. Remove the bracket mounting screw and nut, and remove the front axle case.
3. Remove the tie-rod joint (1) (right side).
4. Remove the cylinder set screw (3).
5. Remove the nipples (2) from steering cylinder.
6. Remove the internal snap ring (4).
7. Draw out the steering cylinder (5).

**(When reassembling)**

- Apply liquid lock (Three Bond 1324 or equivalent) to the tie-rod joint.

Tightening torque	Tie-rod joint to steering cylinder	166.7 to 196.1 N·m 17.0 to 20.0 kgf·m 122.9 to 144.6 ft-lbs
-------------------	------------------------------------	---

- (1) Tie-rod Joint
- (2) Nipple
- (3) Cylinder Set Screw
- (4) Internal Snap Ring
- (5) Steering Cylinder

W10165600

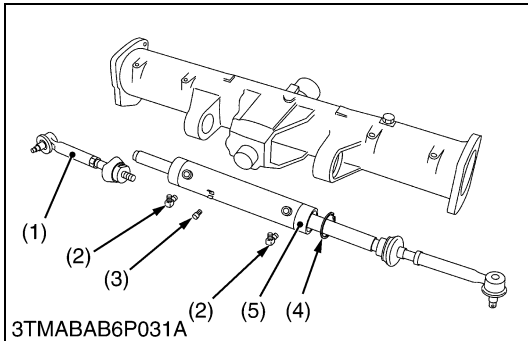



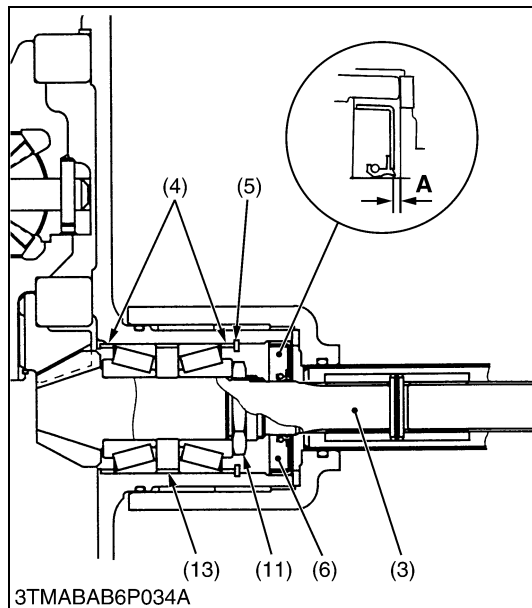
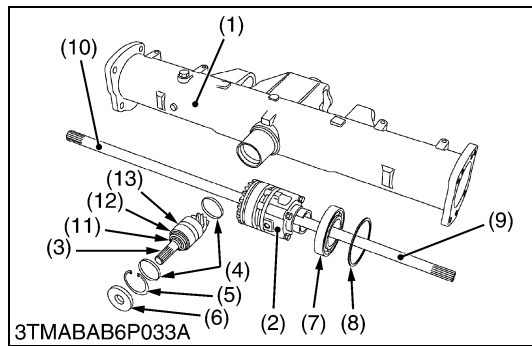
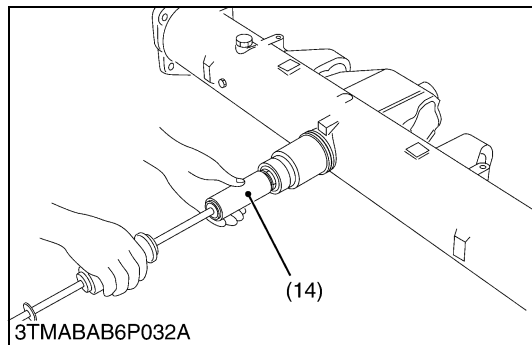

### Spiral Bevel Pinion Shaft and Differential Gear Assembly

1. Take out the differential yoke shaft (9), (10) both sides.
2. Remove the oil seal (6) and internal snap ring (5).
3. Remove the collar (4).
4. Remove the spiral bevel pinion shaft (3) by the pinion shaft remover (14).
5. Take out the differential gear assembly (2), ball bearing (7) and shim (8) from left side of front axle case (1).
6. Remove the stake of lock nut (11), and then remove the lock nut (11).
7. Remove the taper roller bearings (12).

#### (When reassembling)

- Replace the lock nut (11) and oil seal (6) with new ones.
- Apply grease to the oil seal (6).
- Install the shims and collars to their original position.
- Install the taper roller bearings correctly, noting their direction and apply gear oil to them.
- Tighten up the lock nut (11) until the turning force of the spiral bevel pinion shaft reaches the factory specification. (See page 6-S16.)
- When press-fitting an oil seal (6), observe the dimension "A" described in the figure.

#### ■ IMPORTANT

- **After adjusting the turning torque stake the lock nut (11) firmly.**

Turning torque of spiral bevel pinion shaft	Factory spec.	0.98 to 1.18 N·m 0.10 to 0.12 kgf·m 0.72 to 0.89 ft·lbs
---	---------------	---

- (1) Front Axle Case
- (2) Differential Gear Assembly
- (3) Spiral Bevel Pinion Shaft
- (4) Adjusting Collar
- (5) Internal Snap Ring
- (6) Oil Seal
- (7) Ball Bearing
- (8) Shim
- (9) Differential Yoke Shaft R.H.

- (10) Differential Yoke Shaft L.H.
- (11) Lock Nut
- (12) Taper Roller Bearing
- (13) Collar
- (14) Pinion Shaft Remover

**A : Dimension A : 0.5 to 1 mm  
(0.020 to 0.039 in.)**

W10168650



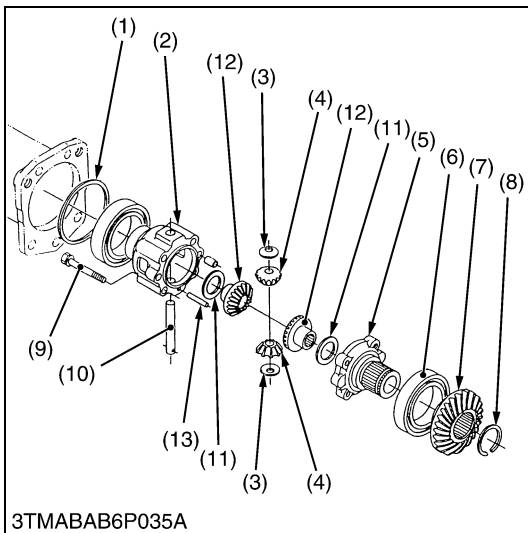

### Differential Gear

1. Remove the differential case cover mounting screws (9) and then take out the differential case cover (5), ball bearing (6) and spiral bevel gear (7) as a unit.
2. Remove the external snap ring (8), and then remove the ball bearing (6) and spiral bevel gear (7) as a unit with a puller.
3. Remove the straight pin (13).
4. Pull out the pinion shaft (10) and take out the differential pinions (4) and differential side gears (12).

#### (When reassembling)

- Apply molybdenum disulfide (Three Bond 1901 or equivalent) to the inner circumferential surface of the differential side gears (12) and differential pinions (4).

Tightening torque	Differential case cover mounting screw	L3130	48.0 to 58.8 N·m
		L3430	4.9 to 6.0 kgf·m
		L3830	35.4 to 43.4 ft-lbs
		L4630	
		L5030	60.8 to 70.6 N·m
			6.2 to 7.2 kgf·m
			44.8 to 52.1 ft-lbs

- |                             |  |
|-----------------------------|--|
| (1) Shim                    | (8) External Snap Ring                     |
| (2) Differential Case       | (9) Differential Case Cover Mounting Screw |
| (3) Thrust Collar           | (10) Pinion Shaft                          |
| (4) Differential Pinion     | (11) Shim                                  |
| (5) Differential Case Cover | (12) Differential Side Gear                |
| (6) Ball Bearing            | (13) Straight Pin                          |
| (7) Spiral Bevel Gear       |  |

W10174670

### [3] SERVICING

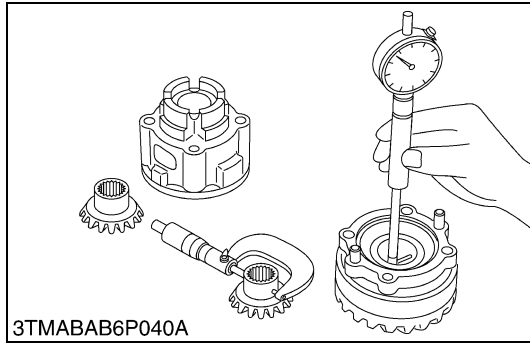

3TMABAB6P040A

#### Clearance between Differential Case (Differential Case Cover) and Differential Side Gear

1. Measure the differential side gear O.D..
2. Measure the differential case bore I.D. and calculate the clearance.
3. Measure the differential case cover bore I.D. and calculate the clearance.
4. If the clearance exceeds the allowable limit, replace faulty parts.

#### **(L3130, L3430, L3830 and L4630)**

Clearance between differential case (differential case cover) and differential side gear	Factory spec.	0.050 to 0.151 mm 0.00197 to 0.00594 in.
	Allowable limit	0.20 mm 0.0079 in.

Differential case bore I.D.	Factory spec.	32.000 to 32.062 mm 1.25984 to 1.26228 in.
Differential case cover bore I.D.	Factory spec.	32.000 to 32.025 mm 1.25984 to 1.26083 in.
Differential side gear O.D.	Factory spec.	31.911 to 31.950 mm 1.25634 to 1.25789 in.

#### **(L5030)**

Clearance between differential case (differential case cover) and differential side gear	Factory spec.	0.050 to 0.114 mm 0.00197 to 0.00449 in.
	Allowable limit	0.20 mm 0.0079 in.

Differential case bore I.D.	Factory spec.	32.000 to 32.025 mm 1.25984 to 1.26083 in.
Differential case cover bore I.D.	Factory spec.	32.000 to 32.025 mm 1.25984 to 1.26083 in.
Differential side gear O.D.	Factory spec.	31.911 to 31.950 mm 1.25634 to 1.25789 in.

W10182040

#### Clearance between Pinion Shaft and Differential Pinion

1. Measure the pinion shaft O.D.
2. Measure the differential pinion I.D. and calculate the clearance.
3. If the clearance exceeds the allowable limit, replace faulty parts.

Clearance between pinion shaft and differential pinion	Factory spec.	0.064 to 0.100 mm 0.00252 to 0.00394 in.
	Allowable limit	0.25 mm 0.0096 in.

Pinion shaft O.D.	Factory spec.	13.950 to 13.968 mm 0.54921 to 0.54992 in.
Differential pinion I.D.	Factory spec.	14.032 to 14.050 mm 0.55244 to 0.55315 in.

W10183690

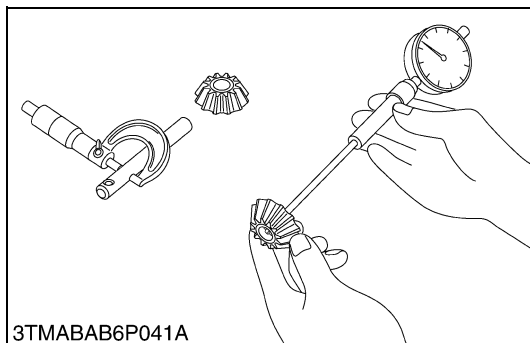

3TMABAB6P041A

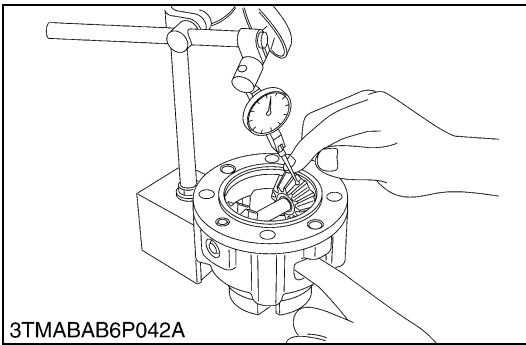

### Backlash between Differential Pinion and Differential Side Gear

1. Set a dial gauge (lever type) on a tooth of the differential pinion.
2. Fix the differential side gear and move the differential pinion to measure the backlash.
3. If the measurement exceeds the factory specifications, adjust with the differential side gears shims.

Backlash between differential pinion and differential side gear	Factory spec.	0.2 to 0.3 mm 0.008 to 0.012 in.
	Allowable limit	0.4 mm 0.016 in.

### (Reference)

- Thickness of adjusting shims
 

0.4 mm (0.016 in.)	1.0 mm (0.039 in.)
0.6 mm (0.024 in.)	1.2 mm (0.047 in.)
0.8 mm (0.031 in.)	
- Tooth contact : More than 35 %

W10185110

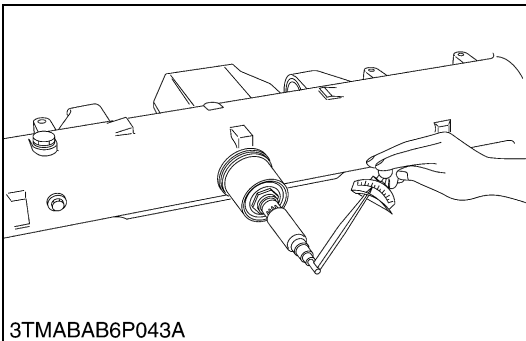

### Turning Torque of Spiral Bevel Pinion Shaft (Pinion Shaft Only)

1. Install the spiral bevel pinion shaft assembly only to the front axle case.
2. Measure the turning torque of spiral bevel pinion shaft.
3. If the turning torque is not within the factory specifications, adjust with the lock nut.

If the turning torque is not able to adjust by lock nut (2), change the thickness of collar (1) and adjust with lock nut (2) again.

### (Reference)

- Standard size of collar (1) : 10.0 mm (0.394 in.) of thickness

Turning torque of spiral bevel pinion shaft	Factory spec.	0.98 to 1.18 N·m 0.10 to 0.12 kgf·m 0.72 to 0.87 ft·lbs
---	---------------	---

### ■ NOTE

- After turning torque adjustment, be sure to stake the lock nut.

(1) Collar

(2) Lock Nut

W10184540

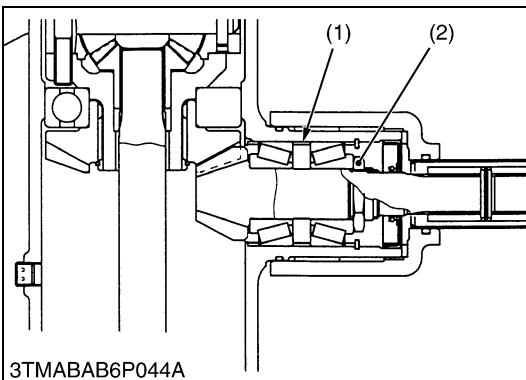

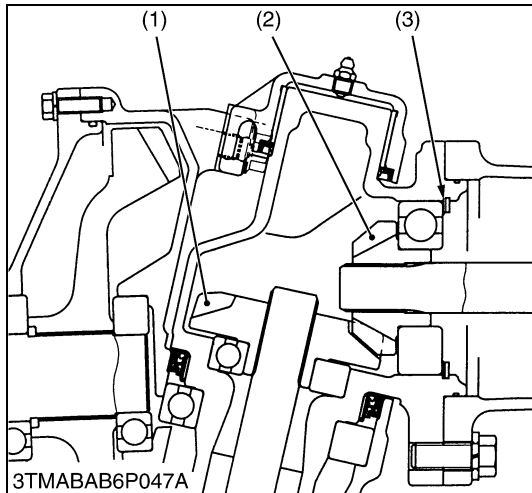
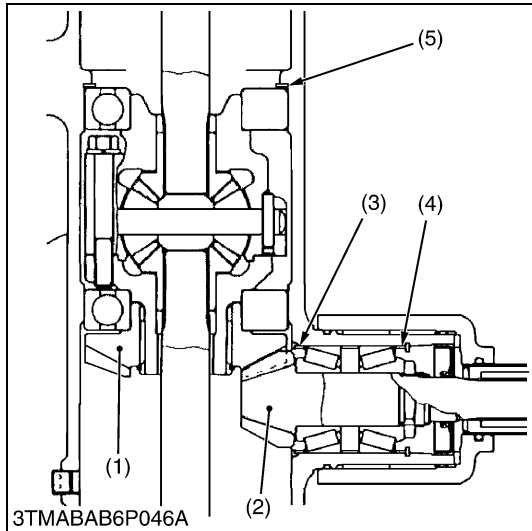
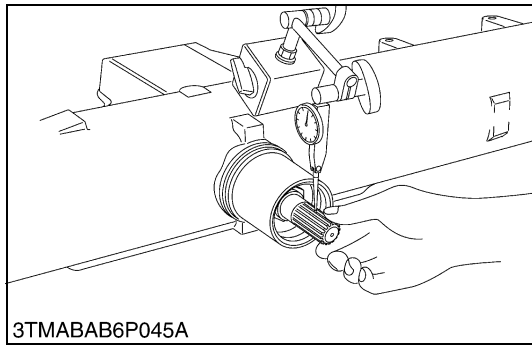

**Backlash between Spiral Bevel Pinion Shaft and Spiral Bevel Gear**

1. Set a dial gauge (lever type) with its finger on the spline of spiral bevel pinion shaft.
2. Measure the backlash by moving the spiral bevel pinion shaft by hand lightly.
3. If the backlash is not within the factory specifications, change the adjusting collar (3), (4).

For example, when the backlash is too large, change the collar (3) to thinner one and change the collar (4) to thicker one. At this time, if the collar (3) is thinned by 1 mm, the collar (4) must be thickened by 1 mm.

**(Reference)**

- Standard size of adjusting collar (3), (4) : 6.0 mm (0.236 in.) of thickness (total 12.0 mm)
- Standard size of adjusting shim (5) : 2.0 mm (0.079 in.) of thickness

4. Adjust the backlash properly by repeating the above procedures.

Backlash between spiral bevel pinion shaft and spiral bevel gear	Factory spec.	L3130 L3430 L3830 L4630	0.1 to 0.3 mm 0.004 to 0.012 in.
	Factory spec.	L5030	0.2 to 0.3 mm 0.008 to 0.012 in.

- (1) Spiral Bevel Gear
- (2) Spiral Bevel Pinion Shaft
- (3) Adjusting Collar
- (4) Adjusting Collar
- (5) Adjusting Shim

W10186900

**Backlash between Bevel Gear and Bevel Gear**

1. Stick a strip of fuse to three spots on the bevel gear (1) with grease.
2. Fix the front axle case, bevel gear case and front gear case.
3. Turn the axle.
4. Remove the bevel gear case from front axle case and measure the thickness of the fuses with an outside micrometer.
5. If the backlash is not within the factory specifications, adjust with shim (3).

Backlash between bevel gear (2) and bevel gear (1)	Factory spec.	0.15 to 0.35 mm 0.006 to 0.014 in.
	Allowable limit	0.6 mm 0.024 in.

**(Reference)**

- Thickness of adjusting shims
  - 0.4 mm (0.016 in.)      1.0 mm (0.039 in.)
  - 0.6 mm (0.024 in.)      1.2 mm (0.047 in.)
  - 0.8 mm (0.031 in.)
- Tooth contact : More than 35 %

- (1) Bevel Gear
- (2) Bevel Gear
- (3) Shim

W10190950

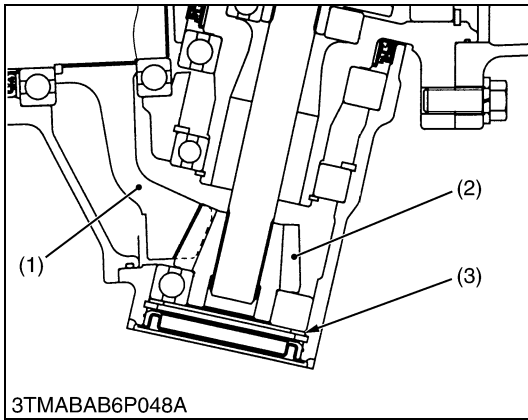

### Backlash between Bevel Gear and Bevel Gear

1. Stick a strip of fuse to three spots on the bevel gear (1) with grease.
2. Fix the axle flange and front gear case.
3. Turn the axle.
4. Remove the axle flange from front gear case and measure the thickness of the fuse with an outside micrometer.
5. If the backlash is not within the factory specifications, adjust with shim (3).

Backlash between bevel gear (2) and bevel gear (1)	Factory spec.	0.2 to 0.3 mm 0.008 to 0.012 in.
	Allowable limit	0.6 mm 0.024 in.

### (Reference)

- Thickness of adjusting shims  
0.4 mm (0.016 in.)      2.0 mm (0.079 in.)  
0.5 mm (0.020 in.)
- Tooth contact : More than 35 %

(1) Bevel Gear  
(2) Bevel Gear

(3) Shim

W10196490

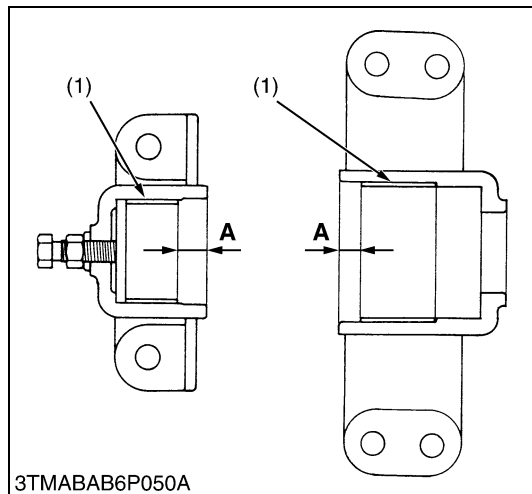
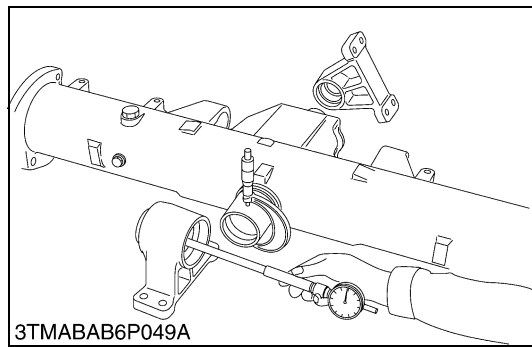

### Clearance between Front Axle Case Bosses and Bracket Bushings

1. Measure the front axle case bosses O.D. with an outside micrometer.
2. Measure the bracket bushing I.D. and calculate the clearance.
3. If the clearance exceeds the allowable limit, replace the bracket bushing.

Clearance between front axle case boss (front) and bracket bushing (front)	Factory spec.	0.120 to 0.275 mm 0.00472 to 0.01083 in.
	Allowable limit	0.50 mm 0.01969 in.

Front axle case boss (front) O.D.	Factory spec.	49.950 to 49.975 mm 1.96653 to 1.96752 in.
Bracket bushing (front) I.D.	Factory spec.	50.095 to 50.225 mm 1.97224 to 1.97736 in.

### (L3130, L3430, L3830 and L4630)

Clearance between front axle case boss (rear) and bracket bushing (rear)	Factory spec.	0.100 to 0.292 mm 0.00394 to 0.01150 in.
	Allowable limit	1.0 mm 0.03937 in.

Front axle case boss (rear) O.D.	Factory spec.	69.970 to 70.000 mm 2.75472 to 2.75590 in.
Bracket bushing (rear) I.D.	Factory spec.	70.100 to 70.262 mm 2.75984 to 2.76622 in.

### (L5030)

Clearance between front axle case boss (rear) and bracket bushing (rear)	Factory spec.	0.025 to 0.195 mm 0.00098 to 0.00768 in.
	Allowable limit	0.50 mm 0.01969 in.

Front axle case boss (rear) O.D.	Factory spec.	80.000 to 80.035 mm 3.14961 to 3.15098 in.
Bracket bushing (rear) I.D.	Factory spec.	80.060 to 80.195 mm 3.15197 to 3.15728 in.

### ■ Press-fitting Bushing

- When press-fitting a new bushing, observe the dimension described in the figure.

Press-fit depth of bushing (A)	Reference value	12.0 to 13.0 mm 0.47 to 0.51 in.
--------------------------------	-----------------	-------------------------------------

### ■ NOTE

- After replacing the bushing, be sure to adjust the front axle rocking force. (See page 6-S6.)

(1) Bushing

(A) Depth of Bushing

W10194290



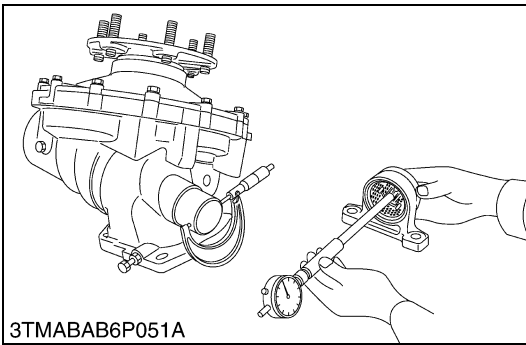

### **Clearance between Bevel Gear Case Boss and Front Axle Support Bushing (for L5030)**

1. Measure the bevel gear case boss O.D. with an outside micrometer.
2. Measure the support bushing I.D. and calculate the clearance.
3. If the clearance exceeds the allowable limit, replace it.

Clearance between bevel gear case boss and front axle support bushing	Factory spec.	0.080 to 0.232 mm 0.00315 to 0.00913 in.
	Allowable limit	1.0 mm 0.03937 in.

Bevel gear case boss O.D.	Factory spec.	54.970 to 55.000 mm 2.16417 to 2.16535 in.
Front axle support bushing I.D.	Factory spec.	55.080 to 55.202 mm 2.16850 to 2.17331 in.

W10198060

# 7 STEERING

# MECHANISM

## CONTENTS

1. STRUCTURE .....	7-M1
2. HYDRAULIC CIRCUIT .....	7-M2
3. HYDRAULIC PUMP .....	7-M3
4. STEERING CONTROLLER .....	7-M4
[1] CONTROL VALVE .....	7-M5
[2] METERING DEVICE (GEROTOR) .....	7-M5
[3] RELIEF VALVE (WITH CHECK VALVE) .....	7-M6
[4] OIL FLOW .....	7-M7
5. STEERING CYLINDER.....	7-M9

# 1. STRUCTURE

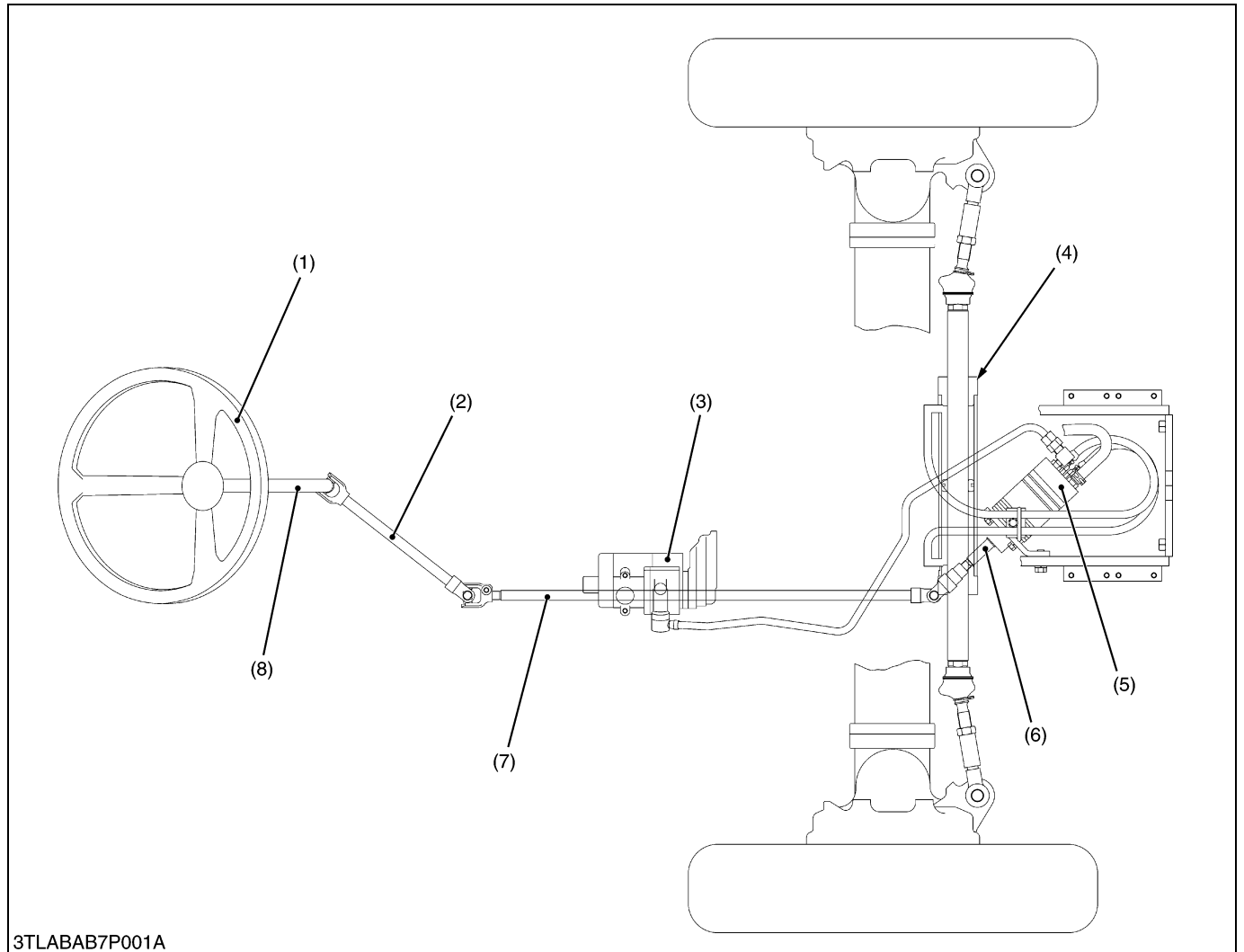

- |                            |                       |                            |                            |
|----------------------------|-----------------------|----------------------------|----------------------------|
| (1) Steering Wheel         | (3) Hydraulic Pump    | (5) Steering Controller    | (7) Steering Joint Shaft 2 |
| (2) Steering Joint Shaft 1 | (4) Steering Cylinder | (6) Steering Joint Shaft 3 | (8) Steering Shaft         |

The full hydrostatic type power steering is used on these tractors. This steering system is composed of steering wheel, steering joint shafts, steering controller, steering cylinder and other components shown in the figure.

## 2. HYDRAULIC CIRCUIT

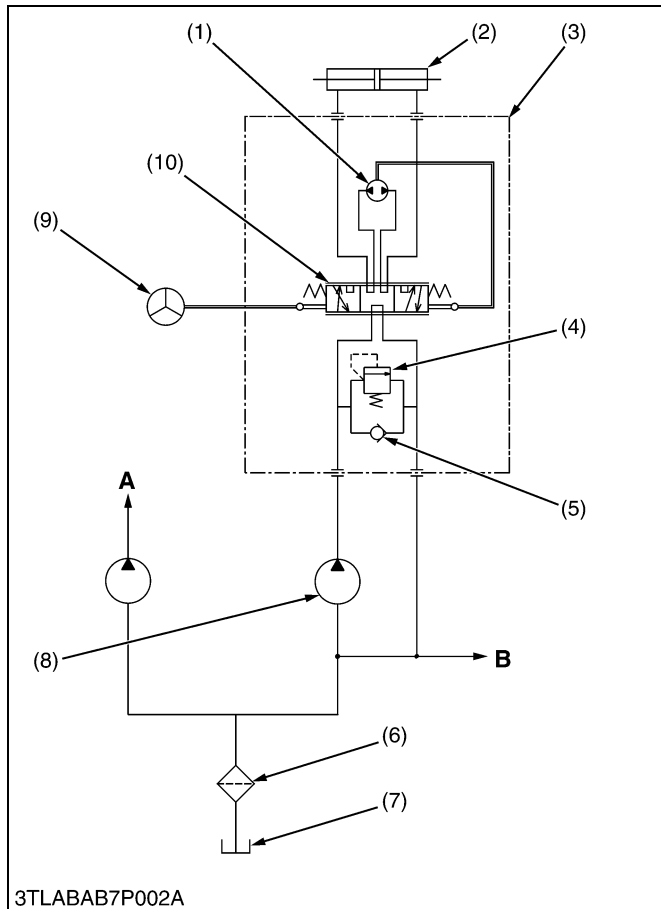

When the engine starts, the hydraulic pump (8) pressure-feeds the oil, drawn from the transmission case (7) through the oil filter (6), to the steering controller (3).

The oil which has entered steering controller (3) is directed to control valve (10).

As the steering wheel is turned, control valve (10) operates and the oil passes through gerotor (1) and into steering cylinder (2). The cylinder rod then moves to control the directional movement of the front wheels.

Return oil from steering cylinder (2) passes through control valve (10) is sent to the PTO clutch valve, HST, GST valve, etc..

When the engine is not operating, and the steering wheel is turned, gerotor (1) rotates to supply oil to steering cylinder (2). Thus the machine can be steered manually.

- (1) Gerotor
- (2) Steering Cylinder
- (3) Steering Controller
- (4) Relief Valve
- (5) Check Valve
- (6) Oil Filter
- (7) Transmission Case
- (8) Hydraulic Pump

- (9) Steering Wheel
- (10) Control Valve

**A : To Three Point Hydraulic System and Others**

**B : To PTO Clutch Valve, HST, GST Valve, etc.**

W1012726

### 3. HYDRAULIC PUMP

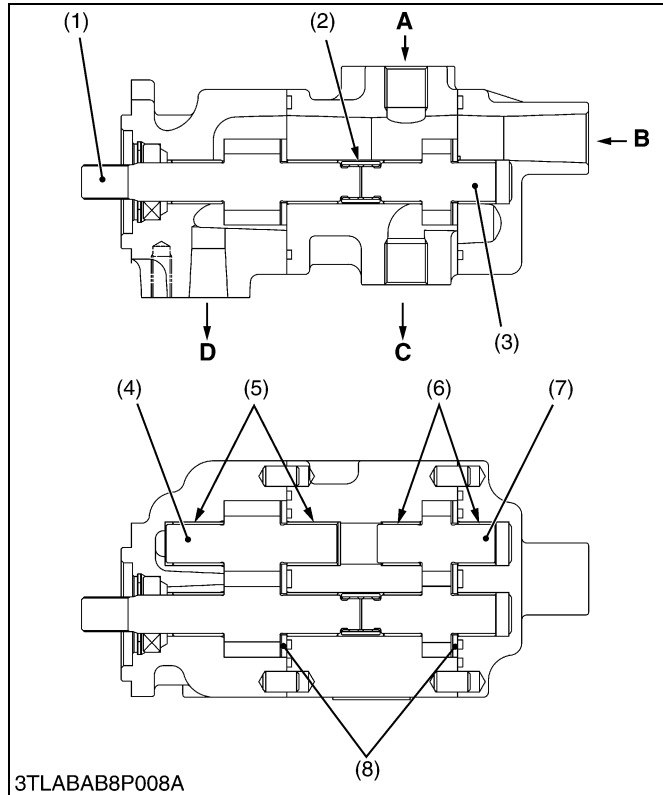

The gear type hydraulic pump is adopted for these tractor. This pump is tandem type and it is composed two pair of gears, side plates, bushings and other components as shown in the figure.

The hydraulic pump pressure-fed the oil drawn from the transmission case through oil filter to power steering circuit and main hydraulic circuit.

- (1) Drive Gear 1
- (2) Coupling
- (3) Drive Gear 2
- (4) Driven Gear 1
- (5) Bushing
- (6) Bushing
- (7) Driven Gear 2
- (8) Side Plate

- A : From Power Steering Controller**
- B : From Transmission Case**
- C : To Power Steering Controller**
- D : To Main Hydraulic Circuit**

W1014335



## 4. STEERING CONTROLLER

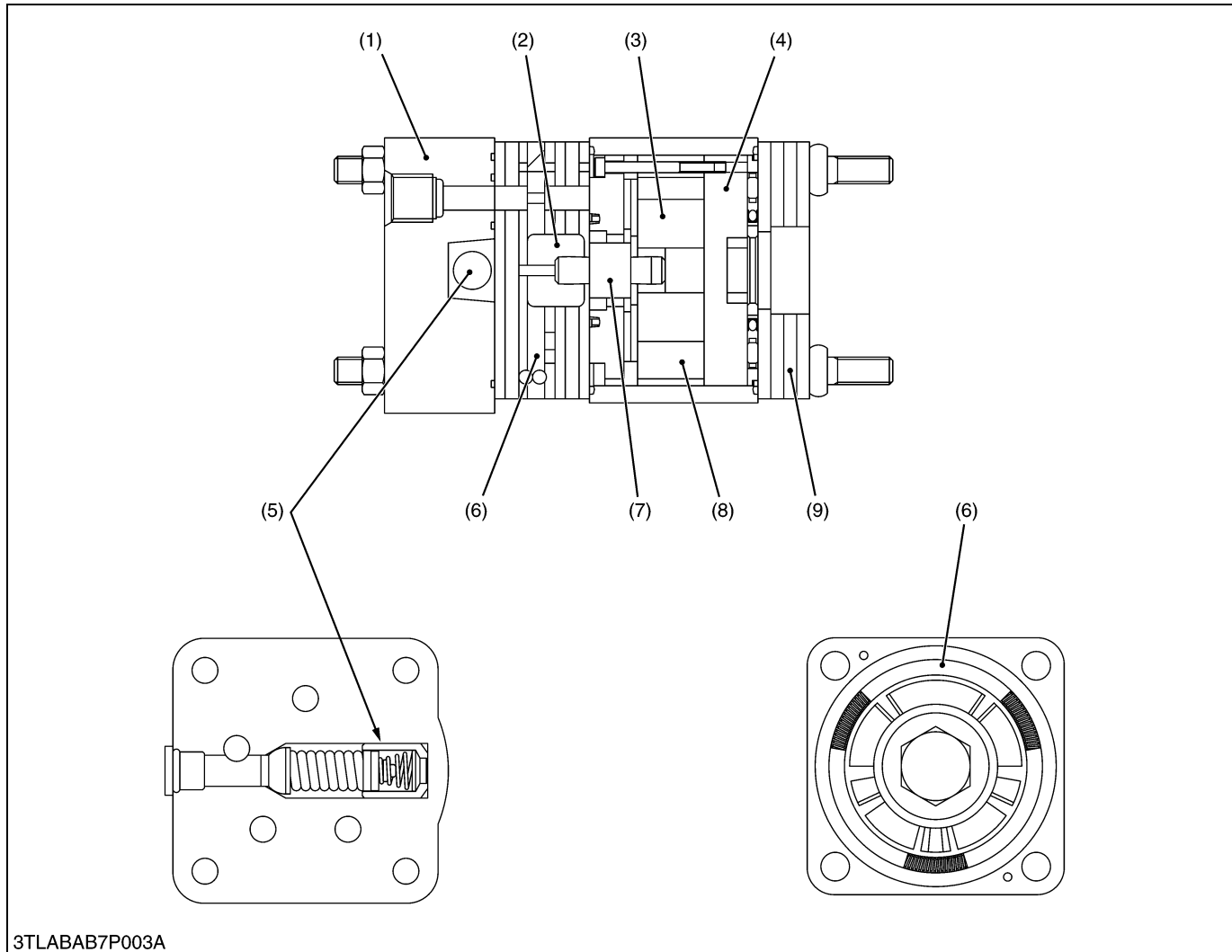

- |                         |                  |                 |                 |
|-------------------------|------------------|-----------------|-----------------|
| (1) Port Cover          | (4) Drive Plate  | (6) Valve Plate | (8) Stator      |
| (2) Hex. Drive Assembly | (5) Relief Valve | (7) Drive Link  | (9) Upper Cover |
| (3) Rotor               |                  |                 |                 |

The steering controller mainly consists of a control valve, a metering device and a relief valve with check valve. The metering device comprises a set of special gear called “**Gerotor**”.

## [1] CONTROL VALVE

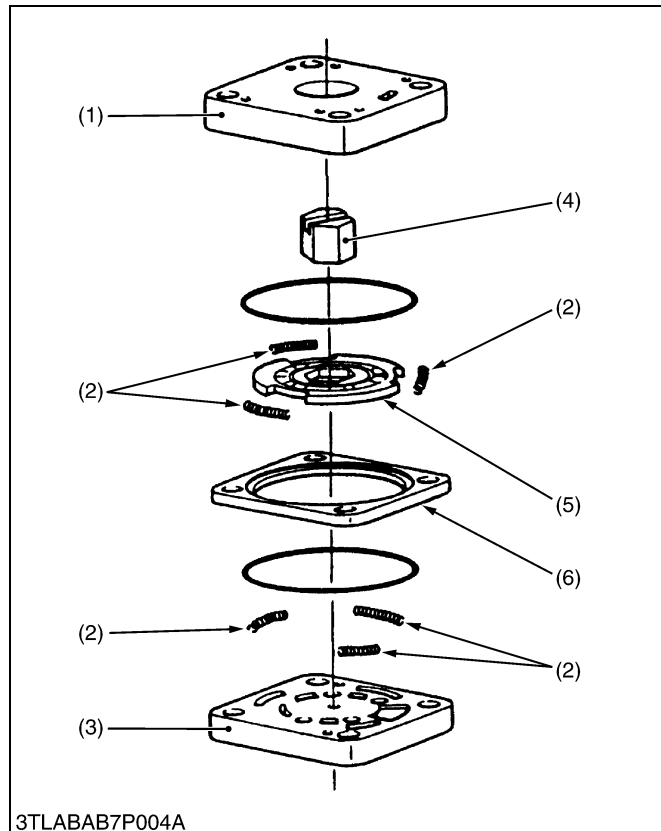

The control valve is a rotary plate type valve. When the steering wheel is not turned, the position of the valve plate (5) and the manifolds (1), (3) is kept neutral by the centering springs (2). This causes the forming of a **“Neutral”** oil circuit.

When the steering wheel is turned either clockwise or counterclockwise, the position of the valve plate (5) and manifolds (1), (3) changes against the centering spring. This allows the forming of a **“Right Turning”** or **“Left Turning”** oil circuit. At the same time, the gerotor rotates with the valve plate and sends the oil to the cylinder corresponding to the rotation of the steering wheel.

- |                        |                         |
|------------------------|-------------------------|
| (1) Isolation Manifold | (4) Hex. Drive Assembly |
| (2) Centering Spring   | (5) Valve Plate         |
| (3) Port Manifold      | (6) Valve Ring          |

W1013040

## [2] METERING DEVICE (GEROTOR)

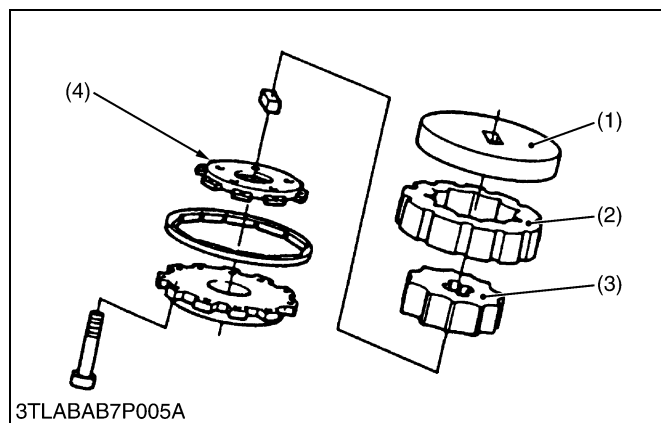

All oil directed from the hydraulic pump to the steering cylinder passes through the metering device (gerotor) on its way. This metering device is a trochoid pump. As the steering wheel is turned, the action is transmitted directly to stator (2) through drive plate (1). Thus, the gerotor sends the amount of oil corresponding to the turn of the steering wheel to the hydraulic cylinder, and the front wheels are moved through the angle corresponding to the turn of the steering wheel.

When the engine is not operating or the hydraulic pump fails. The gerotor serves as a manual pump, and thus the machine can be steered manually.

- |                 |                |
|-----------------|----------------|
| (1) Drive Plate | (3) Rotor      |
| (2) Stator      | (4) Commutator |

W1013277

### [3] RELIEF VALVE (WITH CHECK VALVE)

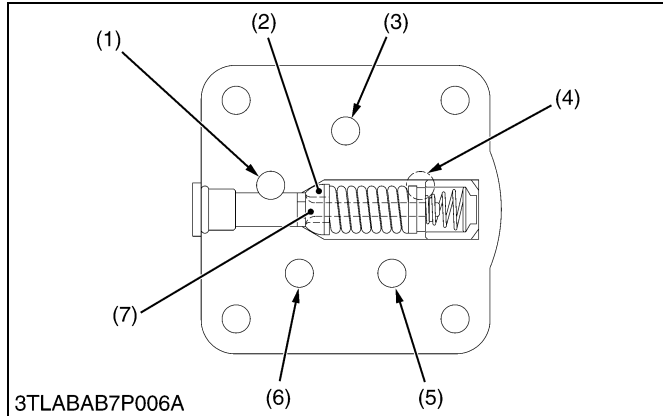

If the pressure in the hydraulic circuit rises above the set pressure of the relief valve, the relief valve will actuate to prevent the pressure from rising further and protect the hydraulic system. Also, if no oil is supplied from the hydraulic pump, the relief valve will act as a check valve and help draw oil from the return oil line to the drain hose, thus making it possible to steer the machine manually.

- (1) Outlet Port
- (2) Check Valve
- (3) Auxiliary Port
- (4) Inlet Port
- (5) R Port
- (6) L Port
- (7) Relief Valve

- [A] Normal Condition
- [B] Relief Valve in Operation
- [C] Check Valve in Operation
- a : From Hydraulic Pump
- b : To Control Valve
- c : From Control Valve
- d : To Drain Hose

W1013357

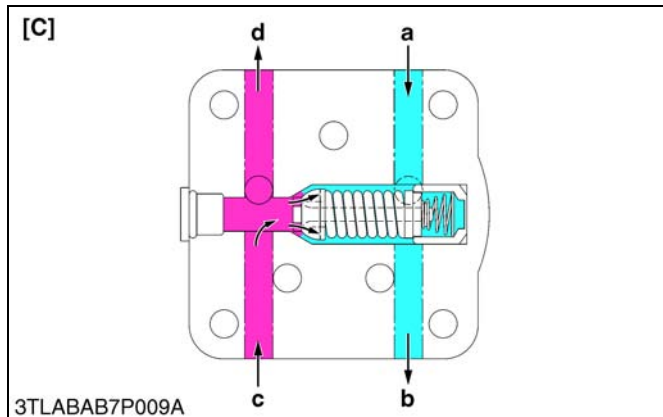
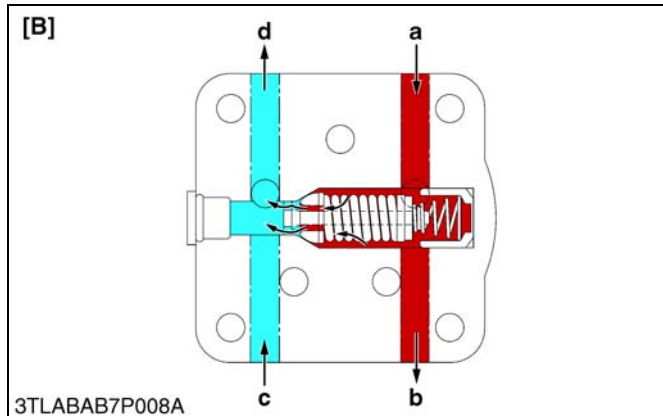
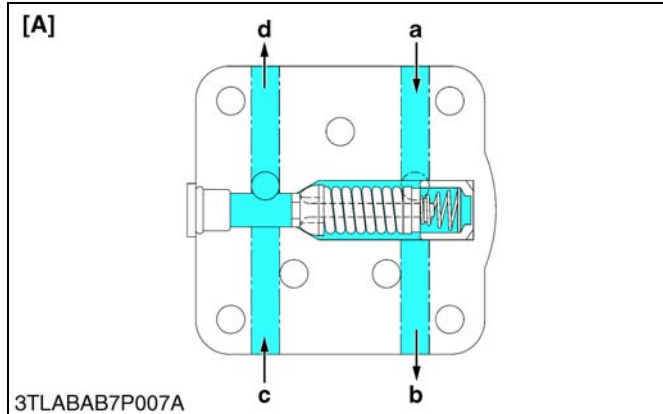

### [4] OIL FLOW

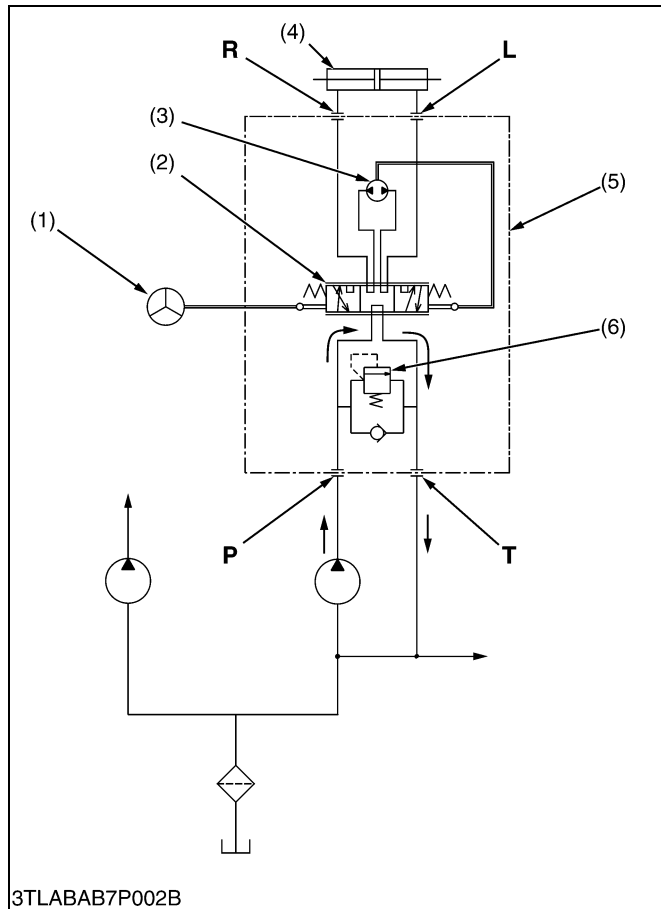

#### ■ Neutral Position

When the steering wheel (1) is not being turned, valve plate (2) is held in the neutral position by centering spring. Under this condition, an oil passage is formed between **P** port (from pump) and **T** port (to transmission case) in the control valve, and all oil from the hydraulic pump flows to **T** port.

- (1) Steering Wheel
- (2) Valve Plate
- (3) Gerotor
- (4) Steering Cylinder
- (5) Steering Controller
- (6) Relief Valve

- P** : Pump Port
- T** : Tank Port
- R** : Cylinder Port R
- L** : Cylinder Port L

W1013515

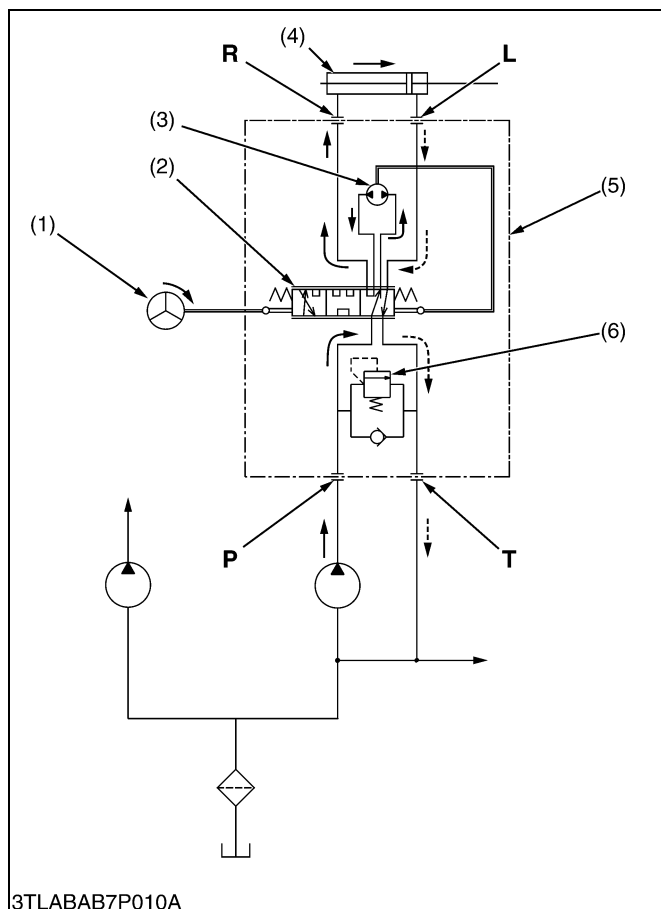

#### ■ Right Turn

When the steering wheel is turned to the right, the action is transmitted through the drive plate, gerotor, and drive link to the control valve. Valve plate (2) then rotates to the right on manifolds, located on the opposite faces of the valve plate (2). Thus, the **P** port passage in the control valve is connected with gerotor (3).

The stator of gerotor (3) turns by the amount corresponding to the turn of the steering wheel (1), and the gerotor performs the metering function and lets oil through it, the amount of which corresponds to the turn of the steering wheel (1).

The oil which has passed through gerotor (3) flows back to the control valve, in which it is directed to cylinder port **R** to operate steering cylinder (4). Consequently, the front wheels are moved to the right through the angle corresponding to the amount of the oil.

When steering cylinder (4) operates, oil returning to cylinder port **L** flows back to the transmission case through the passage connected to **T** port in the control valve.

- (1) Steering Wheel
- (2) Valve Plate
- (3) Gerotor
- (4) Steering Cylinder
- (5) Steering Controller
- (6) Relief Valve

- P** : Pump Port
- T** : Tank Port
- R** : Cylinder Port R
- L** : Cylinder Port L

W1013646

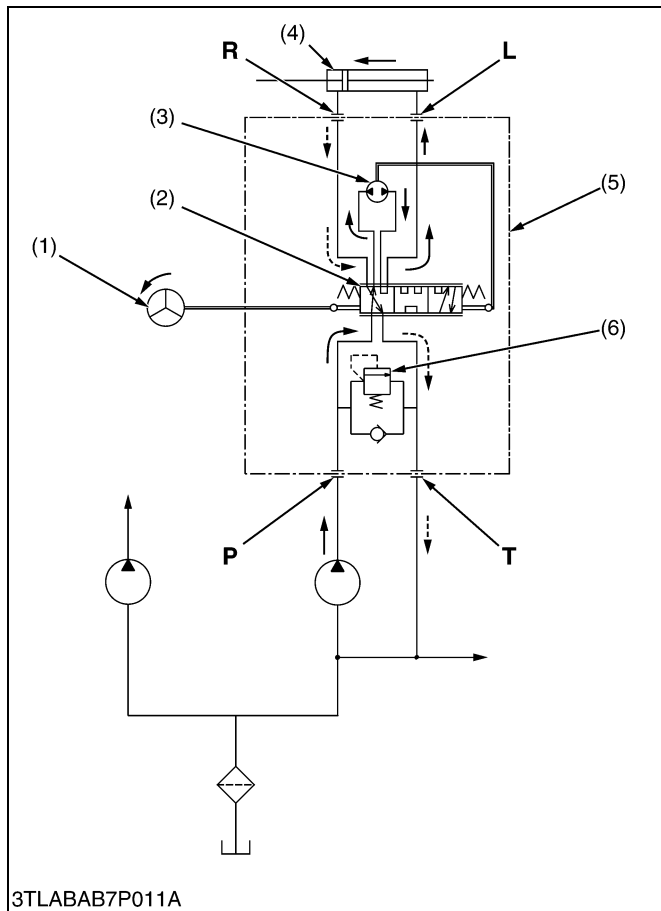

### ■ Left Turn

The steering system operates in the same way at a left-turn as well, except that oil flows into and out of steering cylinder in the directions opposite to those at a right-turn.

- (1) Steering Wheel
- (2) Valve Plate
- (3) Gerotor
- (4) Steering Cylinder
- (5) Steering Controller
- (6) Relief Valve

**P : Pump Port**  
**T : Tank Port**  
**R : Cylinder Port R**  
**L : Cylinder Port L**

W1013826

## 5. STEERING CYLINDER

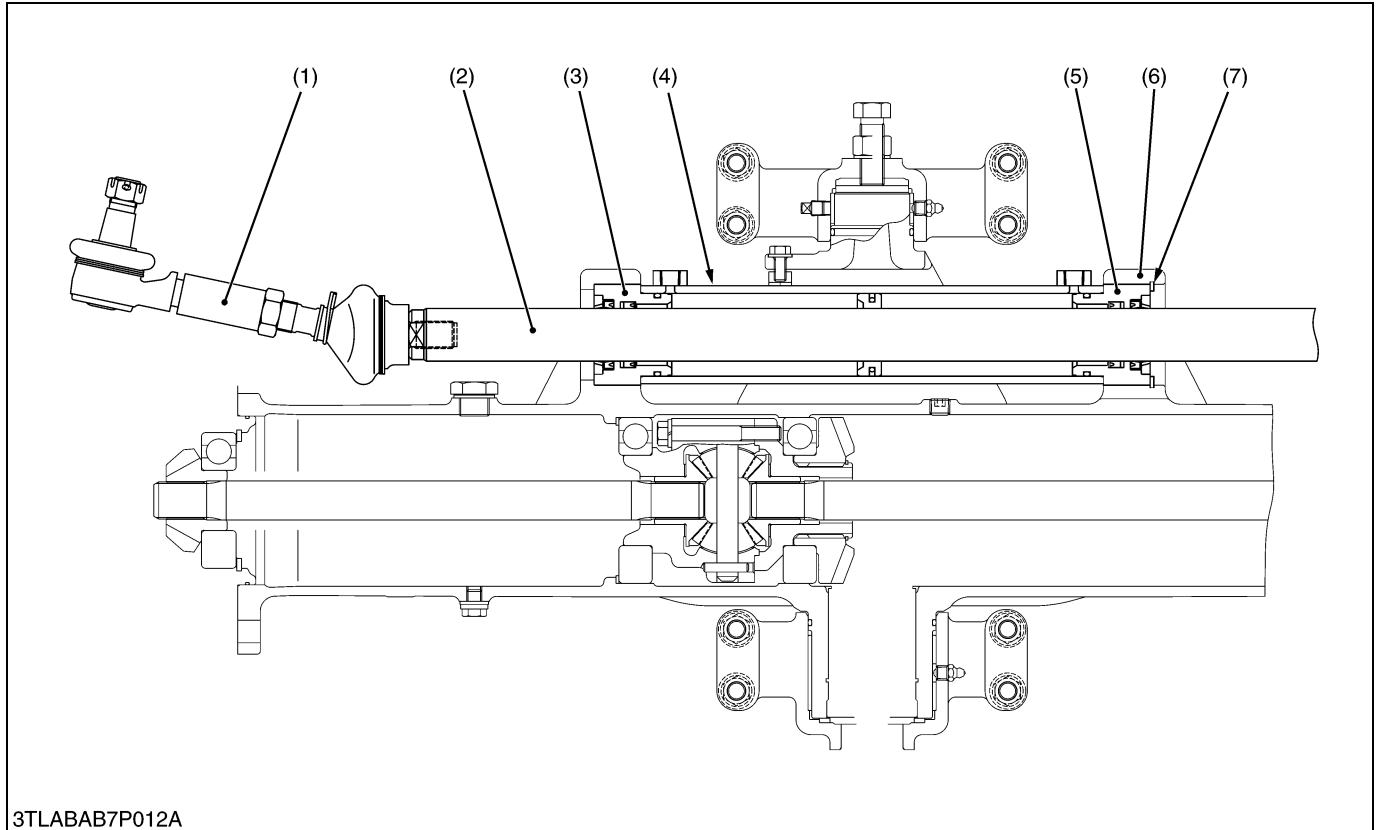

- |                |                   |                     |                        |
|----------------|-------------------|---------------------|------------------------|
| (1) Tie-rod    | (3) Head Cover    | (5) Head Cover      | (7) Internal Snap Ring |
| (2) Piston Rod | (4) Cylinder Tube | (6) Front Axle Case |                        |

The steering cylinder is single piston both rod double-acting type. This steering cylinder is installed parallel to the front axle and connected to tie-rods.

The tie-rods connected to both knuckle arm guarantees equal steering movement to both front wheels.

The steering cylinder provides force in both directions. Depending upon direction the steering wheel is turned pressure oil enters at one end of the cylinder to extend, or the other end to retract it, thereby turning front wheel of the tractor.



# SERVICING

## CONTENTS

1. TROUBLESHOOTING .....	7-S1
2. SERVICING SPECIFICATIONS .....	7-S2
3. TIGHTENING TORQUES .....	7-S3
4. CHECKING, DISASSEMBLING AND SERVICING.....	7-S4
[1] HYDRAULIC PUMP .....	7-S4
(1) Checking.....	7-S4
(2) Disassembling and Assembling.....	7-S8
(3) Servicing .....	7-S10
[2] STEERING CONTROLLER .....	7-S11
(1) Checking.....	7-S11
(2) Disassembling and Assembling.....	7-S12
[3] STEERING CYLINDER.....	7-S13
(1) Disassembling and Assembling.....	7-S13
(2) Servicing .....	7-S14
[4] STEERING LINKAGE .....	7-S14
(1) Disassembling and Assembling.....	7-S14

# 1. TROUBLESHOOTING

Symptom	Probable Cause	Solution	Reference Page
<b>Tractor Can Not Be Steered</b>	<ul style="list-style-type: none"> <li>Steering controller broken</li> <li>Steering linkage broken</li> <li>Pipe broken</li> </ul>	Replace Replace Replace	7-S12 7-S15 –
<b>Front Wheels Vibrate</b>	<ul style="list-style-type: none"> <li>Improper toe-in adjustment</li> <li>Air in the hydraulic system</li> <li>Improperly mounted wheels</li> <li>Tie-rod end loose or worn</li> <li>Clearance between front axle center pivots and bracket bushing excessive</li> <li>Steering controller malfunctioning</li> </ul>	Adjust Bleed Retighten Retighten or replace Replace  Replace	6-S5 7-S12 7-S13 7-S13 6-S19  7-S12
<b>Hard Steering</b>	<ul style="list-style-type: none"> <li>Steering linkage bushings sticking</li> <li>Hydraulic pump malfunctioning</li> <li>Overload</li> <li>Transmission fluid improper or insufficient</li> <li>Oil leak from pipe joint</li>   <li>Insufficient tire pressure</li> <li>Steering controller malfunctioning</li> <li>Relief valve malfunctioning</li> </ul>	Replace Replace – Change or replenish Retighten  Inflate Replace Replace	– 7-S8, S9 – G-7, 8 –  G-55 7-S12 7-S12
<b>Steering Force Fluctuates</b>	<ul style="list-style-type: none"> <li>Air sucked in pump due to leaking or missing of oil</li> <li>Air sucked in pump from suction circuit</li> </ul>	Replenish  Repair	–  –
<b>Excessive Steering Wheel Play</b>	<ul style="list-style-type: none"> <li>Steering linkage worn</li> </ul>	Replace	7-S15
<b>Front Wheels Wander to Right or Left</b>	<ul style="list-style-type: none"> <li>Air sucked in pump due to leak of oil</li> <li>Air sucked in pump from suction circuit</li> <li>Tire pressure uneven</li> <li>Insufficient bleeding</li> <li>Improper toe-in adjustment</li> <li>Clearance between front axle center pivots and brackets bushings excessive</li> <li>Tie-rod end loose or worn</li> <li>Steering linkage worn</li> <li>Steering controller malfunctioning</li> </ul>	Replenish Repair Inflate Bleed Adjust Replace  Retighten or replace Replace Replace	– – G-55 7-S12 6-S5 6-S19  7-S13 7-S15 7-S12
<b>Wheels Are Turned to a Direction Opposite to Steering Direction</b>	<ul style="list-style-type: none"> <li>Power steering hoses connected in reverse</li> </ul>	Repair	7-S12
<b>Noise</b>	<ul style="list-style-type: none"> <li>Air sucked in pump due to lack of oil</li> <li>Air sucked in pump from suction circuit</li> <li>Pipe deformed</li> </ul>	Replenish Repair Replace	– – –

W10143220

## 2. SERVICING SPECIFICATIONS

### HYDRAULIC PUMP

Item		Factory Specification	Allowable Limit
Hydraulic Pump <b>Condition</b>	Delivery at No Pressure	Above 18.6 L/min. 4.91 U.S.gals/min. 4.09 Imp.gals/min.	—
<ul style="list-style-type: none"> <li>Engine Speed : Approx. 2700 min<sup>-1</sup> (rpm)</li> <li>Rated Pressure L3130, L3430, L3830 : 10.7 to 11.7 MPa 109.1 to 119.3 kgf/cm<sup>2</sup> 1552 to 1697 psi L4630, L5030 : 12.7 to 13.7 MPa 129.5 to 139.7 kgf/cm<sup>2</sup> 1842 to 1987 psi</li> <li>Oil Temperature : 40 to 60 °C 104 to 140 °F</li> </ul>	Delivery at Rated Pressure L3130, L3430, L3830, L4630, L5030	Above 18.2L/min. 4.81 U.S.gals/min. 4.00 Imp.gals/min.	16.2 L/min. 4.28 U.S.gals/min. 3.56 Imp.gals/min.
Housing	Depth of Scratch	—	0.09 mm 0.0035 in.
Bushing to Gear Shaft	Clearance	0.020 to 0.081 mm 0.0008 to 0.0032 in.	0.15 mm 0.0059 in.
Gear Shaft	O.D.	14.970 to 14.980 mm 0.5894 to 0.5898 in.	—
Bushing	I.D.	15.000 to 15.051 mm 0.5906 to 0.5926 in.	—
Side Plate	Thickness	2.48 to 2.50 mm 0.0976 to 0.0984 in.	2.40 mm 0.0945 in.

W10138740

### STEERING CONTROLLER

Relief Valve <b>Condition</b>	Setting Pressure		
<ul style="list-style-type: none"> <li>Engine Speed : Maximum</li> <li>Oil Temperature : 40 to 60 °C 104 to 140 °F</li> </ul>	L3130 L3430 L3830	10.7 to 11.7 MPa 109.1 to 119.3 kgf/cm <sup>2</sup> 1552 to 1697 psi	—
	L4630 L5030	12.7 to 13.7 MPa 129.5 to 139.7 kgf/cm <sup>2</sup> 1842 to 1987 psi	—

W10138740

### STEERING CYLINDER

Steering Cylinder	I.D.	55.000 to 55.074 mm 2.16535 to 2.16827 in.	55.100 mm 2.16929 in.
Rod to Bushing	Clearance	0.009 to 0.127 mm 0.00035 to 0.00500 in.	0.135 mm 0.00531 in.

W10151200

### 3. TIGHTENING TORQUES

Tightening torques of screws, bolts and nuts on the table below are especially specified.  
(For general use screws, bolts and nuts : See page G-10.)

Item	N·m	kgf·m	ft-lbs
Regulator delivery pipe joint bolt	39.2 to 49.0	4.0 to 5.0	28.9 to 36.2
Power steering delivery pipe joint bolt (HST model)	39.2 to 49.0	4.0 to 5.0	28.9 to 36.2
Power steering delivery pipe joint bolt (Except HST model)	49.0 to 68.6	5.0 to 7.0	36.2 to 50.6
GST/PTO delivery pipe joint bolt	34.3 to 39.2	3.5 to 4.0	25.3 to 28.9
Regulator valve mounting screw	17.7 to 20.6	1.8 to 2.1	13.0 to 15.2
Hydraulic pump assembly mounting screw and nut	23.5 to 27.5	2.4 to 2.8	17.4 to 20.3
Pump cover mounting screw	39.2 to 44.1	4.0 to 4.5	28.9 to 32.5
Power steering hose retaining nut	24.5 to 29.4	2.5 to 3.0	18.1 to 21.7
Power steering delivery pipe retaining nut	49.0 to 58.8	5.0 to 6.0	36.2 to 43.4
Front wheel mounting nut	137.3	14.0	101.3
Tie-rod end slotted nut (L3130, L3430, L3830, L4630) (L5030)	39.2 to 45.1 156.9 to 176.5	4.0 to 4.6 16.0 to 18.0	28.9 to 33.3 115.7 to 130.2
Tie-rod joint lock nut	166.7 to 196.1	17.0 to 20.0	123.0 to 144.7
Steering wheel mounting nut	48.1 to 55.9	4.9 to 5.7	35.4 to 41.2
Tie-rod joint	166.7 to 196.1	17.0 to 20.0	123.0 to 144.7

W1012736

## 4. CHECKING, DISASSEMBLING AND SERVICING

### [1] HYDRAULIC PUMP

#### (1) Checking

#### (A) Pump Test Using Flow-meter [Manual and Glide Shift Transmission Models]

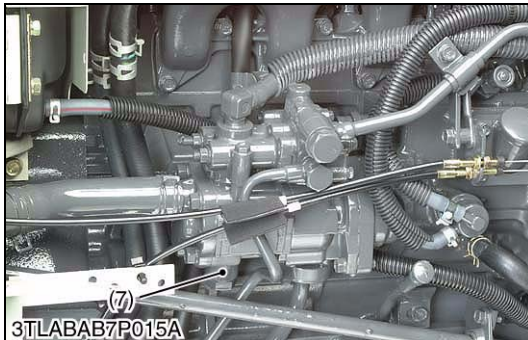
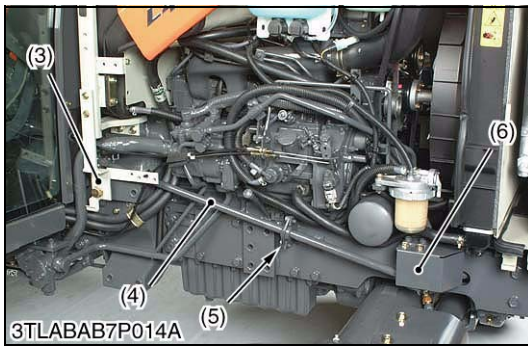

#### Preparation

1. Open the bonnet (1).
2. Remove the side skirt RH (2).
3. Remove the fuel tank frame support (3), cover (6) and steering joint shaft (4).
4. Remove the regulator delivery pipe (7).

#### (When reassembling)

- Install the copper washers firmly.
- Tighten the steering joint shaft bracket mounting screw after adjusting the position of steering joint shaft bracket (5) for smooth rotation of the steering wheel.

Tightening torque	Regulator delivery pipe joint bolt	39.2 to 49.0 N·m 4.0 to 5.0 kgf·m 28.9 to 36.2 ft·lbs

- |                             |                                  |
|-----------------------------|----------------------------------|
| (1) Bonnet                  | (5) Steering Joint Shaft Bracket |
| (2) Side Skirt RH           | (6) Cover                        |
| (3) Fuel Tank Frame Support | (7) Regulator Delivery Pipe      |
| (4) Steering Joint Shaft    |                                  |

W1012306



**Hydraulic Flow Test**

■ **IMPORTANT**

- **When using a flowmeter other than KUBOTA specified flowmeter, be sure to use the instructions with that flowmeter.**
  - **Do not close the flowmeter loading valve completely, before testing, because it has no relief valve.**
1. Loosen the GST/PTO delivery pipe and install the adaptor **52** to the pump discharge port.
  2. Connect the hydraulic test hose to the adaptor **52** and flowmeter inlet port.
  3. Connect the other hydraulic test hose to the flowmeter outlet port and to transmission fluid filling plug hole.
  4. Open the flowmeter loading valve completely. (Turn counterclockwise.)
  5. Start the engine and set the engine speed at **2000 to 2200 min<sup>-1</sup> (rpm)**.
  6. Slowly close the loading valve to generate pressure approx. **9.8 MPa (100 kgf/cm<sup>2</sup>, 1422 psi)**. Hold in this condition until oil temperature reaches approx. 40 °C (104 °F).
  7. Open the loading valve completely.
  8. Set the engine speed. (Refer to **Condition**.)
  9. Read and note the pump delivery at no pressure.
  10. Slowly close the loading valve to increase pressure (Rated pressure). As the load is increased, engine speed drops, therefore, reset the engine speed.
  11. Read and note the pump delivery at rated pressure.
  12. Open the loading valve completely and stop the engine.
  13. If the pump delivery does not reach the allowable limit, check the pump suction line, oil filter or hydraulic pump.

**Condition**

- Engine Speed.....Approx. 2700 min<sup>-1</sup> (rpm)
- Rated pressure
  - L3130, L3430, L3830 .... 10.7 to 11.7 MPa  
109.1 to 119.3 kgf/cm<sup>2</sup>  
1552 to 1697 psi
  - L4630, L5030 ..... 12.7 to 13.7 MPa  
129.5 to 139.7 kgf/cm<sup>2</sup>  
1842 to 1987 psi
- Oil Temperature ..... 40 to 60 °C  
104 to 140 °F

Hydraulic pump delivery at no pressure	Factory spec.	Above 18.6 L/min. 4.91 U.S.gals/min. 4.09 Imp.gals/min.
Hydraulic pump delivery at rated pressure	Factory spec.	Above 18.2 L/min. 4.81 U.S.gals/min. 4.00 Imp.gals/min.
	Allowable limit	16.2 L/min. 4.28 U.S.gals/min. 3.56 Imp.gals/min.

W10128770

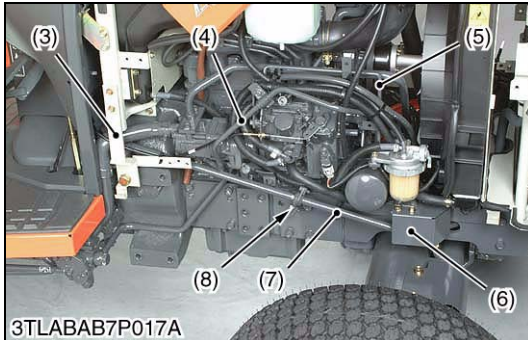

**(B) Pump Test Using Flow-meter [Hydrostatic Transmission Models]****Preparation**

1. Open the bonnet (1).
2. Remove the side skirt RH (2).
3. Remove the fuel tank frame support (3), cover (6) and steering joint shaft (7).
4. Remove the fuel filter bracket (5) and power steering delivery pipe (4).

**(When reassembling)**

- Install the copper washers firmly.
- Tighten the steering joint shaft bracket mounting screw after adjusting the position of steering joint shaft bracket (8) for smooth rotation of the steering wheel.

Tightening torque	Power steering delivery pipe joint bolt	39.2 to 49.0 N·m 4.0 to 5.0 kgf·m 28.9 to 36.2 ft·lbs
-------------------	---	---

- |                                  |                                  |
|----------------------------------|----------------------------------|
| (1) Bonnet                       | (5) Fuel Filter Bracket          |
| (2) Side Skirt RH                | (6) Cover                        |
| (3) Fuel Tank Frame Support      | (7) Steering Joint Shaft         |
| (4) Power Steering Delivery Pipe | (8) Steering Joint Shaft Bracket |

W1013423



### Hydraulic Flow Test

#### ■ IMPORTANT

- When using a flowmeter other than KUBOTA specified flowmeter, be sure to use the instructions with that flowmeter.
- Do not close the flowmeter loading valve completely, before testing, because it has no relief valve.

1. Install the adaptor **52** to the pump discharge port.
2. Connect the hydraulic test hose to the adaptor **52** and flowmeter inlet port.
3. Connect the other hydraulic test hose to the flowmeter outlet port and to transmission fluid filling plug hole.
4. Open the flowmeter loading valve completely. (Turn counterclockwise.)
5. Start the engine and set the engine speed at **2000 to 2200 min<sup>-1</sup> (rpm)**.
6. Slowly close the loading valve to generate pressure approx. **9.8 MPa (100 kgf/cm<sup>2</sup>, 1422 psi)**. Hold in this condition until oil temperature reaches approx. 40 °C (104 °F).
7. Open the loading valve completely.
8. Set the engine speed. (Refer to **Condition**.)
9. Read and note the pump delivery at no pressure.
10. Slowly close the loading valve to increase pressure (Rated pressure). As the load is increased, engine speed drops, therefore, reset the engine speed.
11. Read and note the pump delivery at rated pressure.
12. Open the loading valve completely and stop the engine.
13. If the pump delivery does not reach the allowable limit, check the pump suction line, oil filter or hydraulic pump.

#### Condition

- Engine Speed.....Approx. 2700 min<sup>-1</sup> (rpm)
- Rated pressure
  - L3130, L3430, L3830 .... 10.7 to 11.7 MPa  
109.1 to 119.3 kgf/cm<sup>2</sup>  
1552 to 1697 psi
  - L4630, L5030 ..... 12.7 to 13.7 MPa  
129.5 to 139.7 kgf/cm<sup>2</sup>  
1842 to 1987 psi
- Oil Temperature ..... 40 to 60 °C  
104 to 140 °F

Hydraulic pump delivery at no pressure	Factory spec.	Above 18.6 L/min. 4.91 U.S.gals/min. 4.09 Imp.gals/min.
Hydraulic pump delivery at rated pressure	Factory spec.	Above 18.2 L/min. 4.81 U.S.gals/min. 4.00 Imp.gals/min.
	Allowable limit	16.2 L/min. 4.28 U.S.gals/min. 3.56 Imp.gals/min.

W10139600

## (2) Disassembling and Assembling

### ■ IMPORTANT

- The hydraulic pump is precision machined and assembled : if disassemble once, it may be unable to maintain its original performance. Therefore, when the hydraulic pump fails, replacement should be carried out with the hydraulic pump assembled except when emergency repair is unavoidable.
- When repair is required, follow the disassembly and servicing procedures shown below with utmost care.
- Be sure to test the hydraulic pump with a flowmeter before disassembling.
- After reassembly, be sure to perform break-in operation and ensure that there is nothing abnormal with the hydraulic pump.

### (A) Removing Hydraulic Pump Assembly



#### Bonnet and Side Skirt RH

1. Open the bonnet (1).
2. Remove the side skirt RH (2).

(1) Bonnet

(2) Side Skirt RH

W1014408

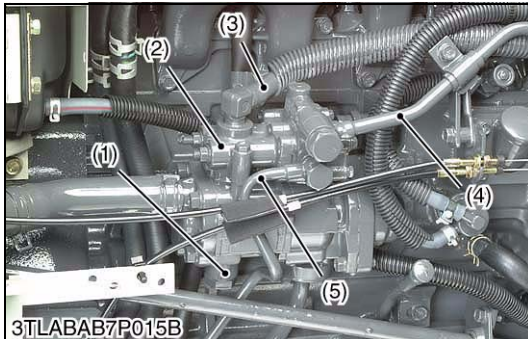

#### Regulator Valve (Manual and Glide Shift Transmission Models)

1. Disconnect the power steering delivery pipe (4) and return hose (3).
2. Disconnect the GST/PTO delivery pipe (5) and regulator delivery pipe (1).
3. Remove the regulator valve (2).

#### **(When reassembling)**

- Apply grease to the O-ring and take care not to damage it.
- Install the copper washer firmly.

Tightening torque	Power steering delivery pipe joint bolt	49.0 to 68.6 N·m 5.0 to 7.0 kgf·m 36.2 to 50.6 ft-lbs
	GST/PTO delivery pipe joint bolt	34.3 to 39.2 N·m 3.5 to 4.0 kgf·m 25.3 to 28.9 ft-lbs
	Regulator delivery pipe joint bolt	39.2 to 49.0 N·m 4.0 to 5.0 kgf·m 28.9 to 36.2 ft-lbs
	Regulator valve mounting screw	17.7 to 20.6 N·m 1.8 to 2.1 kgf·m 13.0 to 15.2 ft-lbs

(1) Regulator Delivery Pipe

(4) Power Steering Delivery Pipe

(2) Regulator Valve

(5) GST/PTO Delivery Pipe

(3) Return Hose

W1014496

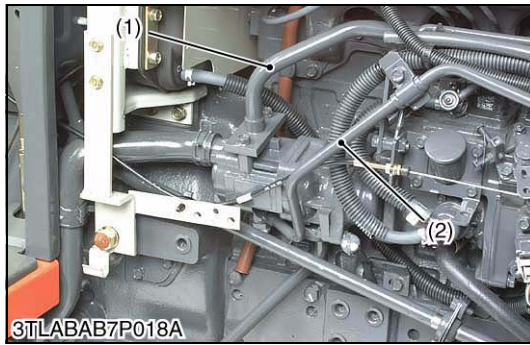

### **Power Steering Delivery Pipe and Oil Cooler Return Pipe (HST Models)**

1. Disconnect the power steering delivery pipe (2) and oil cooler return pipe (1).

#### **(When reassembling)**

- Install the copper washers firmly.
- Take care not to damage the O-ring.

Tightening torque	Power steering delivery pipe joint bolt	39.2 to 49.0 N·m 4.0 to 5.0 kgf·m 28.9 to 36.2 ft·lbs

(1) Oil Cooler Return Pipe

(2) Power Steering Delivery Pipe

W1014726

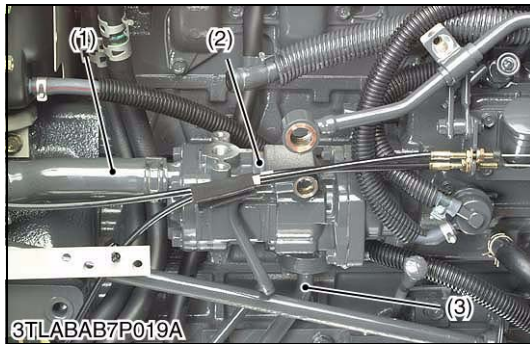

### **Hydraulic Pump Assembly**

1. Disconnect the suction hose (1) and main delivery pipe (3).
2. Remove the hydraulic pump assembly (2).

#### **(When reassembling)**

- Apply grease to the O-ring and take care not to damage it.

Tightening torque	Hydraulic pump assembly mounting screw and nut	23.5 to 27.5 N·m 2.4 to 2.8 kgf·m 17.4 to 20.3 ft·lbs

(1) Suction Hose

(3) Main Delivery Pipe

(2) Hydraulic Pump Assembly

W1014977

## **(B) Disassembling Hydraulic Pump**

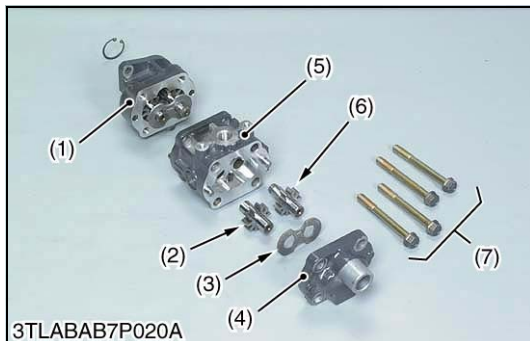

### **Hydraulic Pump Assembly**

1. Remove the pump cover mounting screws (7).
2. Remove the drive gear (6), driven gear (2) and side plate (3) from the casing.

#### **(When reassembling)**

- Take care not to damage the gasket.
- Align the hole of the pump cover (4) and casing 2 (5).
- Install the side plate, noting its location and direction.
- Install the gears, noting its direction.

Tightening torque	Pump cover mounting screw	39.2 to 44.1 N·m 4.0 to 4.5 kgf·m 28.9 to 32.5 ft·lbs

(1) Casing 1

(5) Casing 2

(2) Driven Gear

(6) Drive Gear

(3) Side Plate

(7) Screw

(4) Pump Cover

W10135590



**Hydraulic Pump Running-In**

After reassembly, perform break-in operation in the following manner, and check the pump for abnormality before use. If the pump temperature should rise noticeably during running-in, recheck should be performed.

1. Install the hydraulic pump to the tractor, and mount the suction pipe and delivery pipe securely.
2. Set the engine speed at 1300 to 1500 min<sup>-1</sup> (rpm), and operate the hydraulic pump at no load for about 10 minutes.
3. Set the engine speed at 2000 to 2200 min<sup>-1</sup> (rpm), and with the hydraulic pump applied with 2.94 MPa (30 kgf/cm<sup>2</sup>, 427 psi) to 4.90 MPa (50 kgf/cm<sup>2</sup>, 711 psi) pressure, operate it for approx. 15 minutes.
4. With the engine set to maximum speed, fully turn the steering wheel to the left or right, then actuate the relief valve five times for 25 seconds (one time 5 seconds).

W10145360

**(3) Servicing****Housing Bore (Depth of Scratch)**

1. Check for the scratch on the interior surface of the housing caused by the gear.
2. If the scratch reaches more than half the area of the interior surface of the housing, replace at pump assembly.
3. Measure the housing I.D. where the interior surface is not scratched, and measure the housing I.D. where the interior surface is scratched.
4. If the values obtained in the two determinations differ by more than the allowable limit, replace the hydraulic pump as a unit.

Depth of scratch	Allowable limit	0.09 mm 0.0035 in.
------------------	-----------------	-----------------------

**(Reference)**

- Use a cylinder gauge to measure the housing I.D.

W10146490

**Clearance between Bushing and Gear Shaft**

1. Measure the gear shaft O.D. with an outside micrometer.
2. Measure the bushing I.D. with an inside micrometer or cylinder gauge, and calculate the clearance.
3. If the clearance exceeds the allowable limit, replace the gear shaft and the bushings as a unit.

Clearance between bushing and gear shaft	Factory spec.	0.020 to 0.081 mm 0.0008 to 0.0032 in.
	Allowable limit	0.15 mm 0.0059 in.

Gear shaft O.D.	Factory spec.	14.970 to 14.980 mm 0.5894 to 0.5898 in.
Bushing I.D.	Factory spec.	15.000 to 15.051 mm 0.5906 to 0.5926 in.

W1015746



**Side Plate Thickness**

1. Measure the side plate thickness with an outside micrometer.
2. If the thickness is less than the allowable limit, replace it.

Side plate thickness	Factory spec.	2.48 to 2.50 mm 0.0976 to 0.0984 in.
	Allowable limit	2.40 mm 0.0945 in.

W10134960

**[2] STEERING CONTROLLER**

**(1) Checking**



**Relief Valve Setting Pressure Test**

1. Disconnect the power steering hose **LT**.
2. Install the power steering tee fitting adaptor to the steering controller and connect the power steering hose **LT**.
3. Install the adaptor **D** to the power steering tee fitting adaptor and set the cable and pressure gauge.
4. Start the engine and set the engine speed at maximum speed.
5. Fully turn the steering wheel to the left and read the pressure when the relief valve functions.
6. Stop the engine.
7. If the pressure is not within the factory specifications, check the pump delivery line or replace the steering controller assembly.

Power steering relief valve setting pressure	Factory spec.	L3130	10.7 to 11.7 MPa
		L3430	109.1 to 119.3 kgf/cm <sup>2</sup>
		L3830	1552 to 1697 psi
		L4630	12.7 to 13.7 MPa
		L5030	129.5 to 139.7 kgf/cm <sup>2</sup>
			1842 to 1987 psi

Tightening torque	Power steering hose retaining nut	24.5 to 29.4 N·m 2.5 to 3.0 kgf·m 18.1 to 21.7 ft·lbs
-------------------	-----------------------------------	---

**Condition**

- Engine speed.....Maximum
- Oil temperature.....40 to 60 °C  
104 to 140 °F

W1016736



## (2) Disassembling and Assembling

### ■ IMPORTANT

- Use only the transmission fluid (See page G-7, 8), in no case use mixture of oils of different brands.
- Before disassembling the power steering system hydraulic components, check the performance of hydraulic pump and power steering using a flowmeter.
- After removing or disassembling the power steering hydraulic components, be sure to bleed air.

### [Bleeding]

1. Start the engine.
2. Turn the steering wheels slowly in both directions all the way alternately several times, and stop the engine.

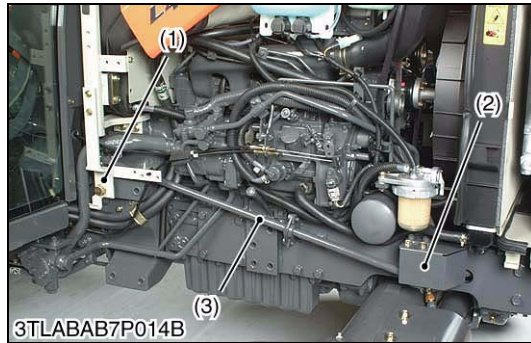

### Fuel Tank Frame Support, Cover and Steering Joint Shaft 2

1. Remove the fuel tank frame support (1) and cover (2).
2. Remove the steering joint shaft 2 (3).

### (When reassembling)

- Tighten the steering joint shaft bracket mounting screw after adjusting the position of steering joint shaft bracket (4) for smooth rotation of the steering wheel.

- |                             |                                  |
|-----------------------------|----------------------------------|
| (1) Fuel Tank Frame Support | (3) Steering Joint Shaft 2       |
| (2) Cover                   | (4) Steering Joint Shaft Bracket |

W1017095

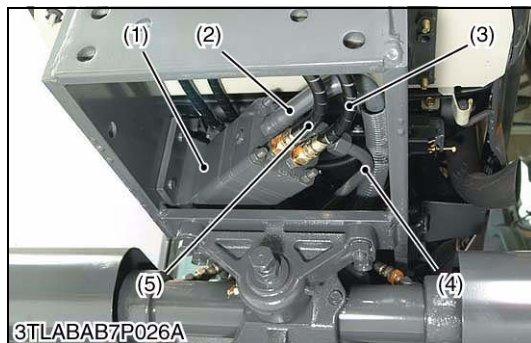
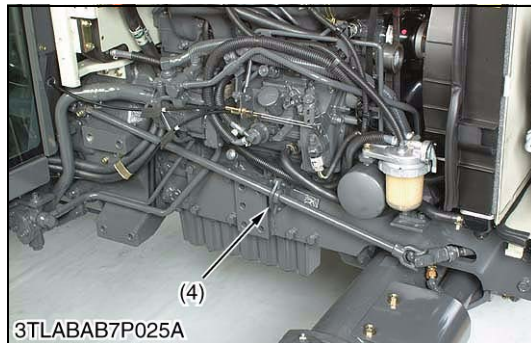

### Steering Controller Assembly

1. Disconnect the power steering delivery pipe (4), steering hoses (3), (5) and return hose (2).
2. Remove the steering controller mounting screw (6) and take out the steering controller assembly (1).

### (When reassembling)

- Reinstall the steering hoses (3), (5) to their original position.

Tightening torque	Power steering delivery pipe retaining nut	49.0 to 58.8 N·m 5.0 to 6.0 kgf·m 36.2 to 43.4 ft·lbs
	Steering hose retaining nut	24.5 to 29.4 N·m 2.5 to 3.0 kgf·m 18.1 to 21.7 ft·lbs

- |                         |                                  |
|-------------------------|----------------------------------|
| (1) Steering Controller | (4) Power Steering Delivery Pipe |
| (2) Return Hose         | (5) Steering Hose LH             |
| (3) Steering Hose RH    | (6) Screw                        |

W1017229



### [3] STEERING CYLINDER

#### (1) Disassembling and Assembling



3TLABAB7P031A

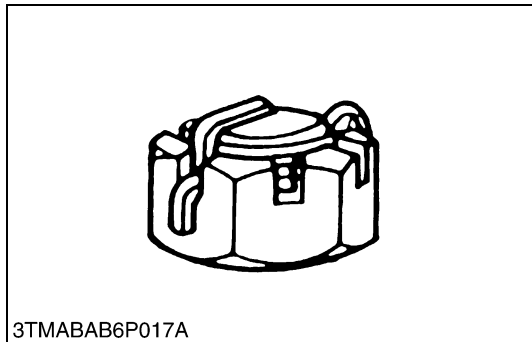

3TMABAB6P017A

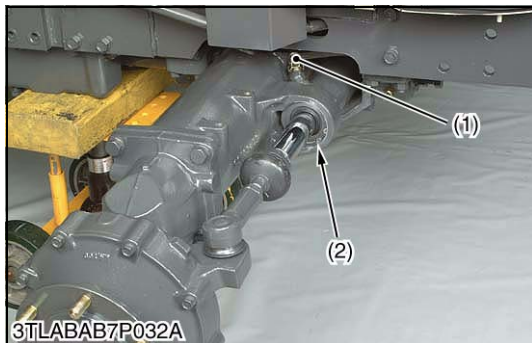

3TLABAB7P032A

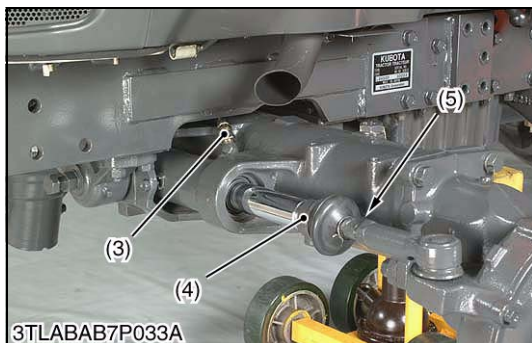

3TLABAB7P033A

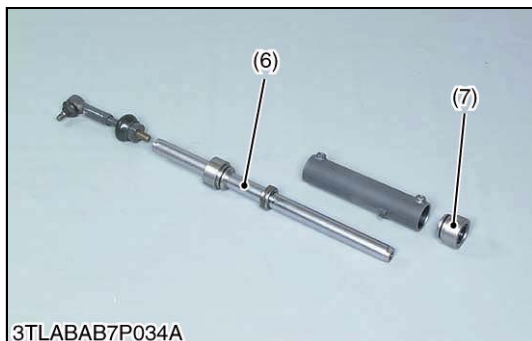

3TLABAB7P034A

#### Front Wheel, Cylinder Cover and Tie-rod

1. Place a disassembly stand under the engine and support it with a jack.
2. Remove the front wheel and cylinder cover (2).
3. Pull out the cotter pin and remove the tie-rod end slotted nut.
4. Disconnect the tie-rod (1).

#### (When reassembling)

- After tightening the tie-rod end slotted nut to the specified torque, install a cotter pin as shown in the figure.

Tightening torque	Front wheel mounting nut		137.3 N·m 14.0 kgf·m 101.3 ft·lbs
	Tie-rod end slotted nut	L3130	39.2 to 45.1 N·m
		L3430	4.0 to 4.6 kgf·m
		L3830	28.9 to 33.3 ft·lbs
	L4630		
	L5030		156.9 to 176.5 N·m 16.0 to 18.0 kgf·m 115.7 to 130.2 ft·lbs

(1) Tie-rod

(2) Cylinder Cover

W1018390

#### Steering Cylinder

1. Disconnect the power steering hoses (1), (3) and remove the elbows.
2. Disconnect the tie-rod joint LH (4).
3. Remove the internal snap ring (2).
4. Take out the steering cylinder to the left.
5. Remove the head cover (7) and draw out the cylinder rod (6).

#### (When reassembling)

- Apply transmission fluid to the oil seal and O-ring.
- Apply liquid lock (Three Bond 1324B or equivalent) to the thread of tie-rod joint (4).

Tightening torque	Power steering hose retaining nut	24.5 to 29.4 N·m 2.5 to 3.0 kgf·m 18.1 to 21.7 ft·lbs
	Tie-rod joint	166.7 to 196.1 N·m 17.0 to 20.0 kgf·m 123.0 to 144.7 ft·lbs
	Tie-rod joint lock nut	166.7 to 196.1 N·m 17.0 to 20.0 kgf·m 123.0 to 144.7 ft·lbs

(1) Power Steering Hose RH

(5) Lock Nut

(2) Internal Snap Ring

(6) Cylinder Rod

(3) Power Steering Hose LH

(7) Head Cover

(4) Tie-rod Joint

W1018590

**(2) Servicing****Steering Cylinder I.D.**

1. Measure the steering cylinder I.D. with a cylinder gauge.
2. If the cylinder I.D. exceed the allowable limit, replace the cylinder tube.

Steering cylinder I.D.	Factory spec.	55.000 to 55.074 mm 2.16535 to 2.16827 in.
	Allowable limit	55.100 mm 2.16929 in.

W1019033

**Clearance between Rod and Bushing**

1. Measure the bushing I.D. with a cylinder gauge.
2. Measure the rod O.D. with a outside micrometer, and calculate the clearance.
3. If the clearance exceeds the allowable limit, replace as a unit.

Clearance between rod and bushing	Factory spec.	0.009 to 0.127 mm 0.00035 to 0.00500 in.
	Allowable limit	0.135 mm 0.00531 in.

W10182660

**[4] STEERING LINKAGE****(1) Disassembling and Assembling****Steering Wheel and Steering Post Covers**

1. Remove the steering wheel (1).
2. Remove the steering post covers (2), (3).

**(When reassembling)**

Tightening torque	Steering wheel mounting nut	48.1 to 55.9 N·m 4.9 to 5.7 kgf·m 35.4 to 41.2 ft·lbs
-------------------	-----------------------------	---

- (1) Steering Wheel  
(2) Steering Post Cover 1

- (3) Steering Post Cover 2

W1019416





### **Side Skirt, Fuel Tank Frame Support and Cover**

1. Open the bonnet (1).
2. Remove the side skirt RH (2).
3. Remove the fuel tank frame support (3) and cover (4).

- |                   |                             |
|-------------------|-----------------------------|
| (1) Bonnet        | (3) Fuel Tank Frame Support |
| (2) Side Skirt RH | (4) Cover                   |

W1019511

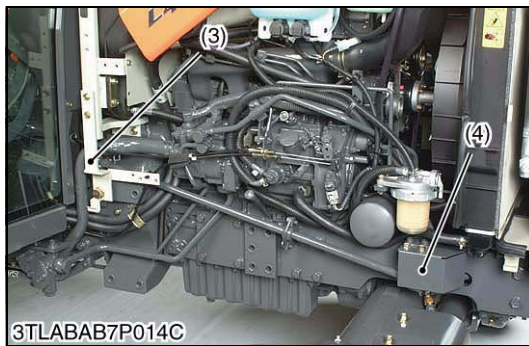

### **Steering Joint Shaft 2**

1. Remove the screw (3) and steering joint shaft bracket mounting screw.
2. Remove the steering joint shaft 2 (1).

#### **(When reassembling)**

- Tighten the steering joint shaft bracket mounting screw after adjusting the position of steering joint shaft bracket (2) for smooth rotation of the steering wheel.

- |                                  |           |
|----------------------------------|-----------|
| (1) Steering Joint Shaft 2       | (3) Screw |
| (2) Steering Joint Shaft Bracket |           |

W1019696

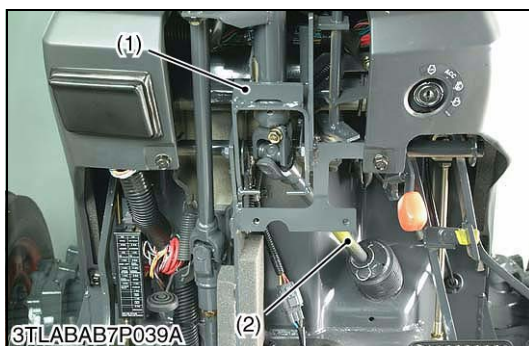
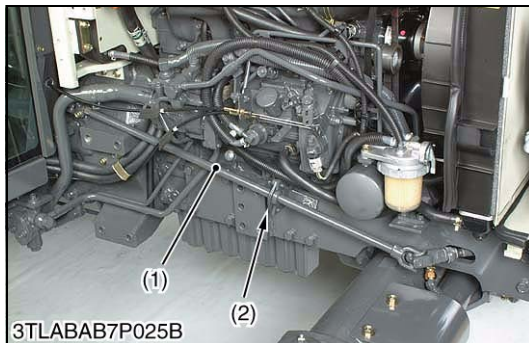

### **Steering Joint Shaft 1 and Steering Post**

1. Remove the steering joint shaft 1 (2).
2. Remove the steering post (1).

- |                   |                            |
|-------------------|----------------------------|
| (1) Steering Post | (2) Steering Joint Shaft 1 |
|-------------------|----------------------------|

W1019851

# **8 HYDRAULIC SYSTEM**

# MECHANISM

## CONTENTS

1. STRUCTURE .....	8-M1
[1] MANUAL TRANSMISSION AND GLIDE SHIFT TRANSMISSION.....	8-M1
[2] HYDROSTATIC TRANSMISSION.....	8-M2
2. HYDRAULIC CIRCUIT.....	8-M3
[1] MANUAL TRANSMISSION.....	8-M3
[2] GLIDE SHIFT TRANSMISSION.....	8-M4
[3] HYDROSTATIC TRANSMISSION.....	8-M6
3. HYDRAULIC PUMP .....	8-M8
4. FRONT HYDRAULIC BLOCK.....	8-M9
5. REAR HYDRAULIC BLOCK .....	8-M10
6. POSITION CONTROL VALVE.....	8-M11
7. POSITION CONTROL LINKAGE.....	8-M13
8. POSITION CONTROL WITH DRAFT CONTROL LINKAGE .....	8-M14
9. MIXED CONTROL .....	8-M17
10. LOWERING SPEED ADJUSTING VALVE.....	8-M18
11. HYDRAULIC CYLINDER .....	8-M19
12. AUXILIARY CONTROL VALVE .....	8-M20
[1] DOUBLE ACTING TYPE 1 .....	8-M20
[2] DOUBLE ACTING TYPE 2 (FLOATING WITH DETENT) .....	8-M21
[3] SINGLE ACTING TYPE .....	8-M23



# 1. STRUCTURE

## [1] MANUAL TRANSMISSION AND GLIDE SHIFT TRANSMISSION

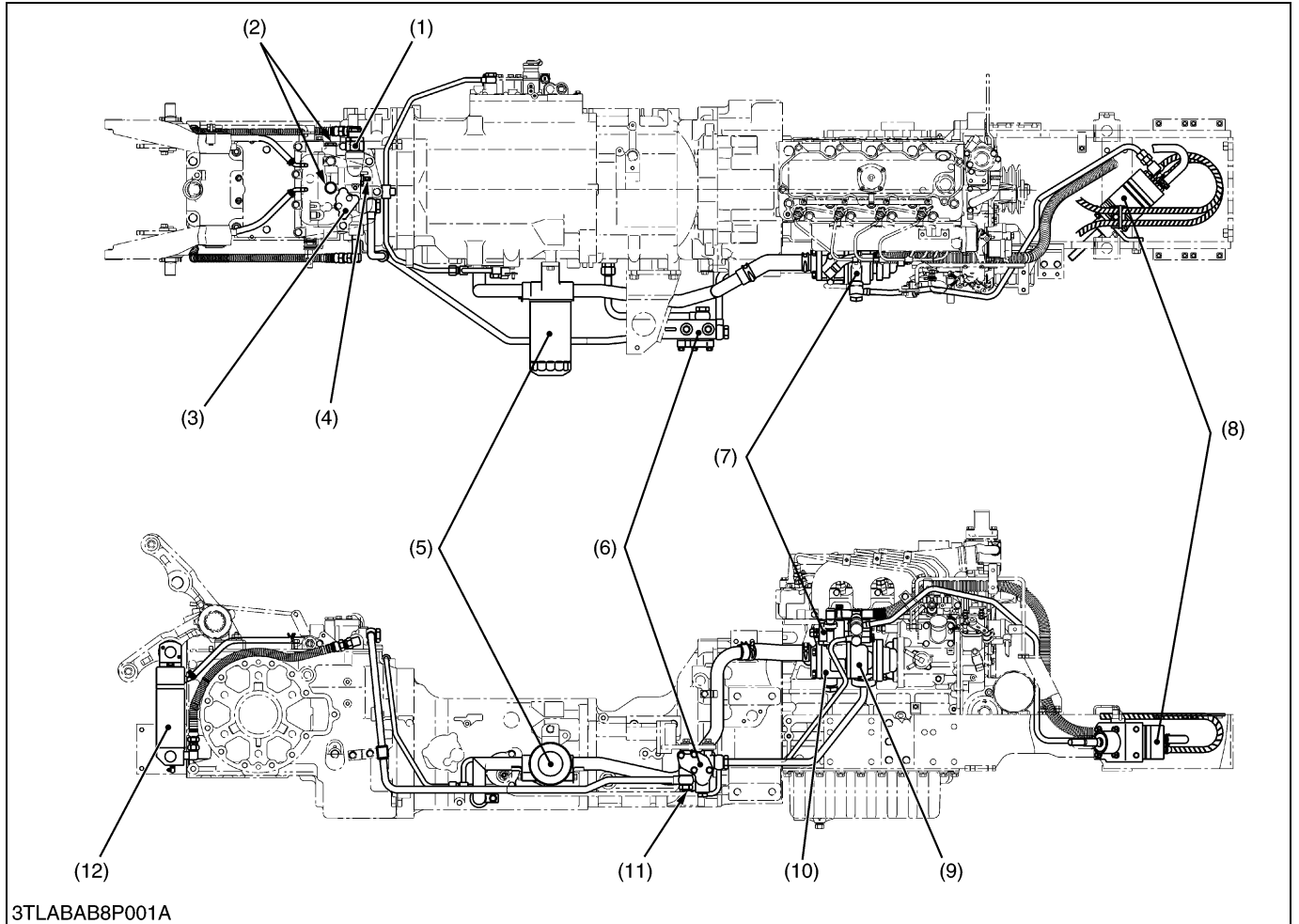

- |                           |                                    |                               |                         |
|---------------------------|------------------------------------|-------------------------------|-------------------------|
| (1) Cylinder Safety Valve | (4) Lowering Speed Adjusting Valve | (7) Regulator Valve           | (10) Hydraulic Pump 2   |
| (2) Check Valve           | (5) Oil Filter                     | (8) Power Steering Controller | (11) Relief Valve       |
| (3) Rear Hydraulic Outlet | (6) Front Hydraulic Block          | (9) Hydraulic Pump 1          | (12) Hydraulic Cylinder |

The hydraulic system of manual transmission and glide shift transmission models are composed of two hydraulic pumps, relief valve, position control valve, hydraulic cylinder, oil filter and other components as shown in the figure.

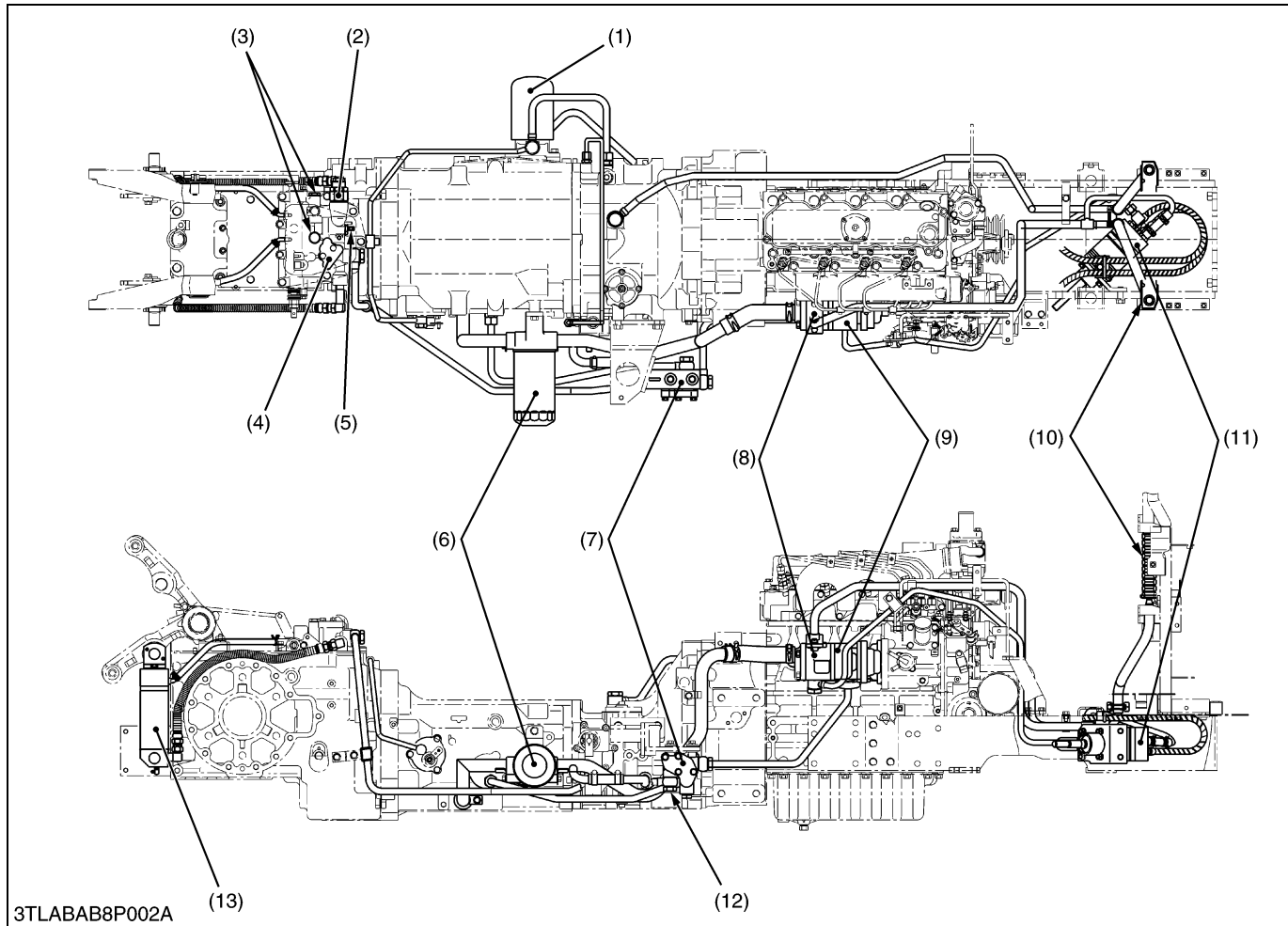
**[2] HYDROSTATIC TRANSMISSION**

- |                           |                                    |                      |                                |
|---------------------------|------------------------------------|----------------------|--------------------------------|
| (1) Oil Filter (HST)      | (5) Lowering Speed Adjusting Valve | (8) Hydraulic Pump 2 | (11) Power Steering Controller |
| (2) Cylinder Safety Valve | (6) Oil Filter                     | (9) Hydraulic Pump 1 | (12) Relief Valve              |
| (3) Check Valve           | (7) Front Hydraulic Block          | (10) Oil Cooler      | (13) Hydraulic Cylinder        |
| (4) Rear Hydraulic Outlet |                                    |                      |                                |

The hydraulic system of hydrostatic transmission model is composed of two hydraulic pumps, relief valve, position control valve, hydraulic cylinder, oil filters, oil cooler and other components as shown in the figure.

## 2. HYDRAULIC CIRCUIT

### [1] MANUAL TRANSMISSION

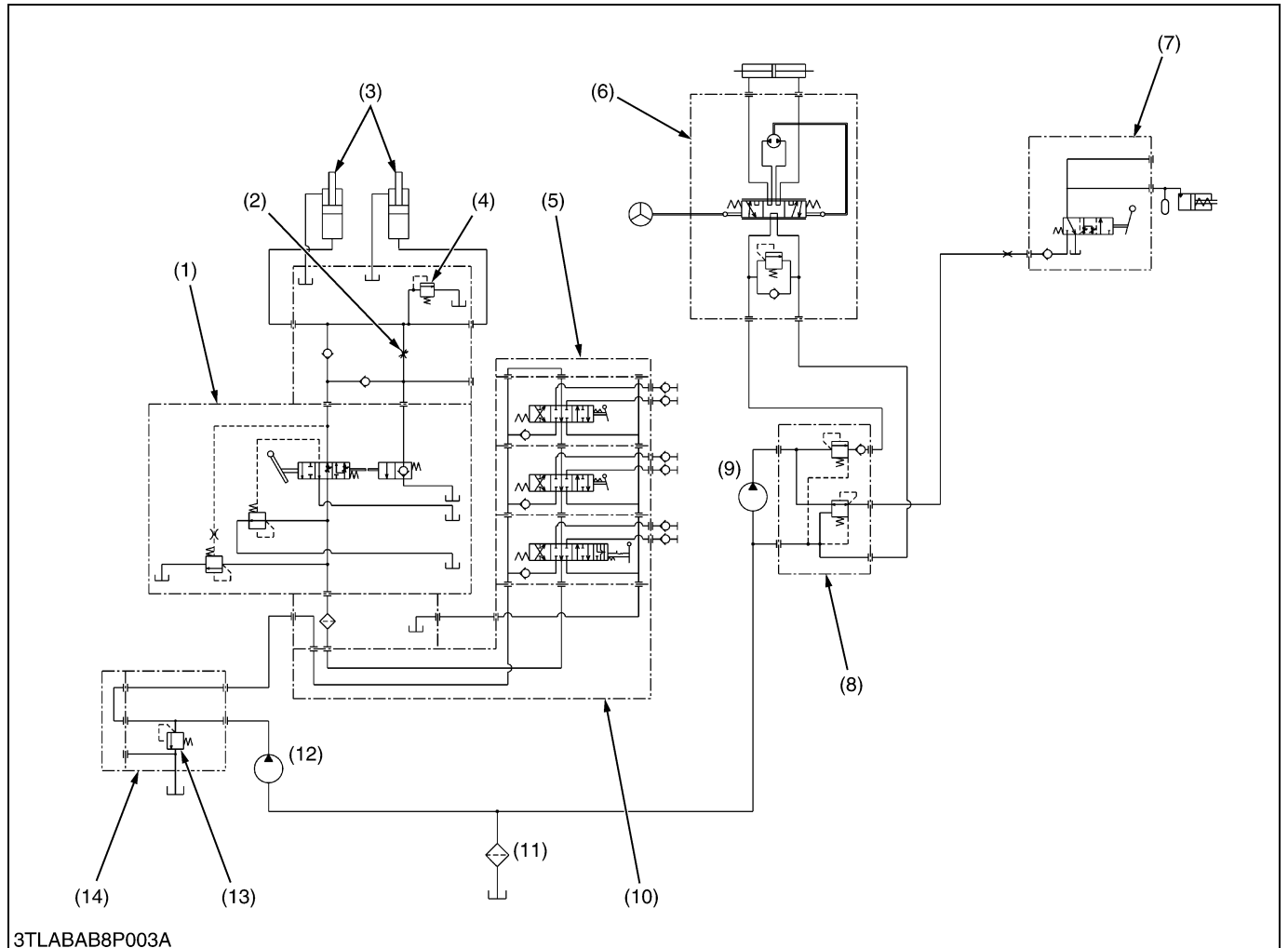

- |                                    |   |   |                            |
|------------------------------------|---|---|----------------------------|
| (1) Position Control Valve         | (5) Auxiliary Control Valve                               | (8) Regulator Valve (Refer to TRANSMISSION Section) | (11) Oil Filter            |
| (2) Lowering Speed Adjusting Valve | (6) Power Steering Controller (Refer to STEERING Section) | (9) Hydraulic Pump 2                                | (12) Hydraulic Pump 1      |
| (3) Hydraulic Cylinder             | (7) PTO Clutch Valve (Refer to TRANSMISSION Section)      | (10) Rear Hydraulic Block                           | (13) Relief Valve          |
| (4) Cylinder Safety Valve          |   |   | (14) Front Hydraulic Block |

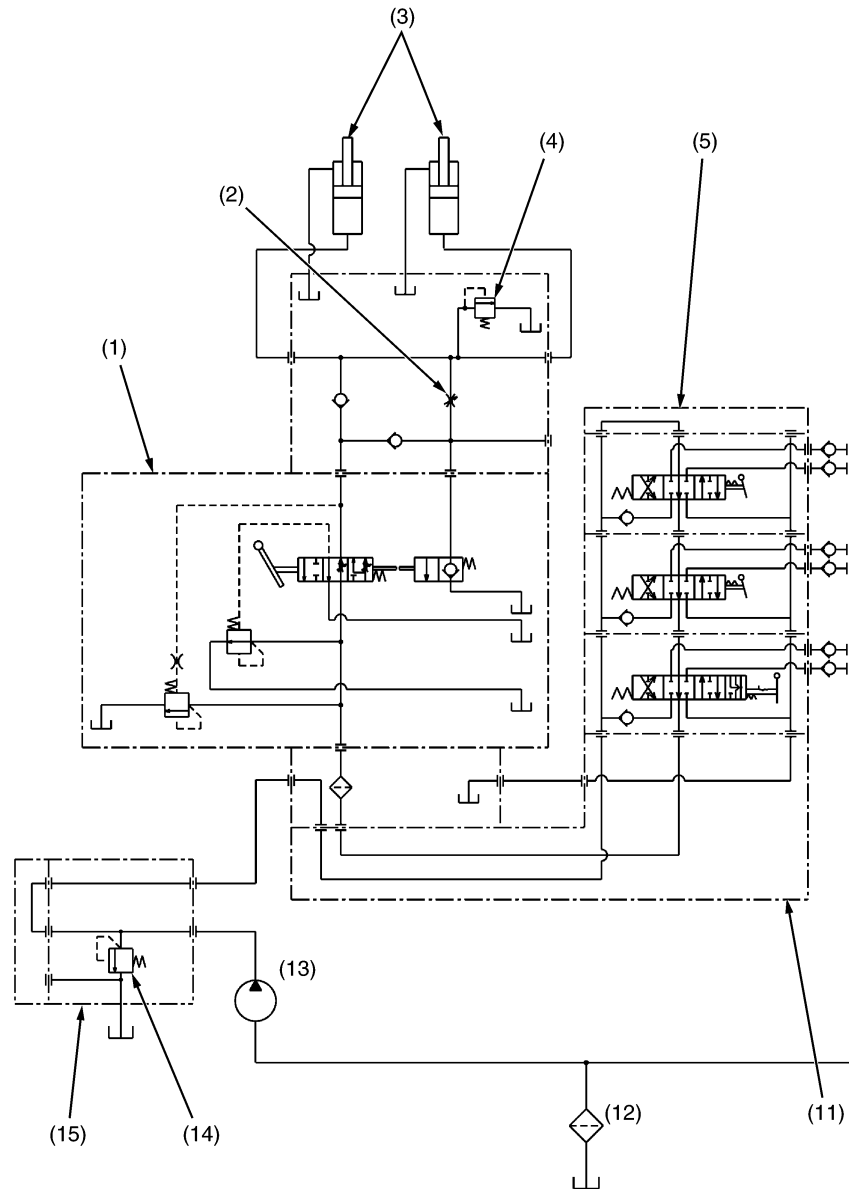
**[2] GLIDE SHIFT TRANSMISSION**

3TLABAB8P004A

- |                                    |                           |   |  |
|------------------------------------|---------------------------|---|--|
| (1) Position Control Valve         | (3) Hydraulic Cylinder    | (5) Auxiliary Control Valve                               | (7) PTO Clutch Valve (Refer to TRANSMISSION Section)   |
| (2) Lowering Speed Adjusting Valve | (4) Cylinder Safety Valve | (6) Power Steering Controller (Refer to STEERING Section) | (8) GST Valve Assembly (Refer to TRANSMISSION Section) |

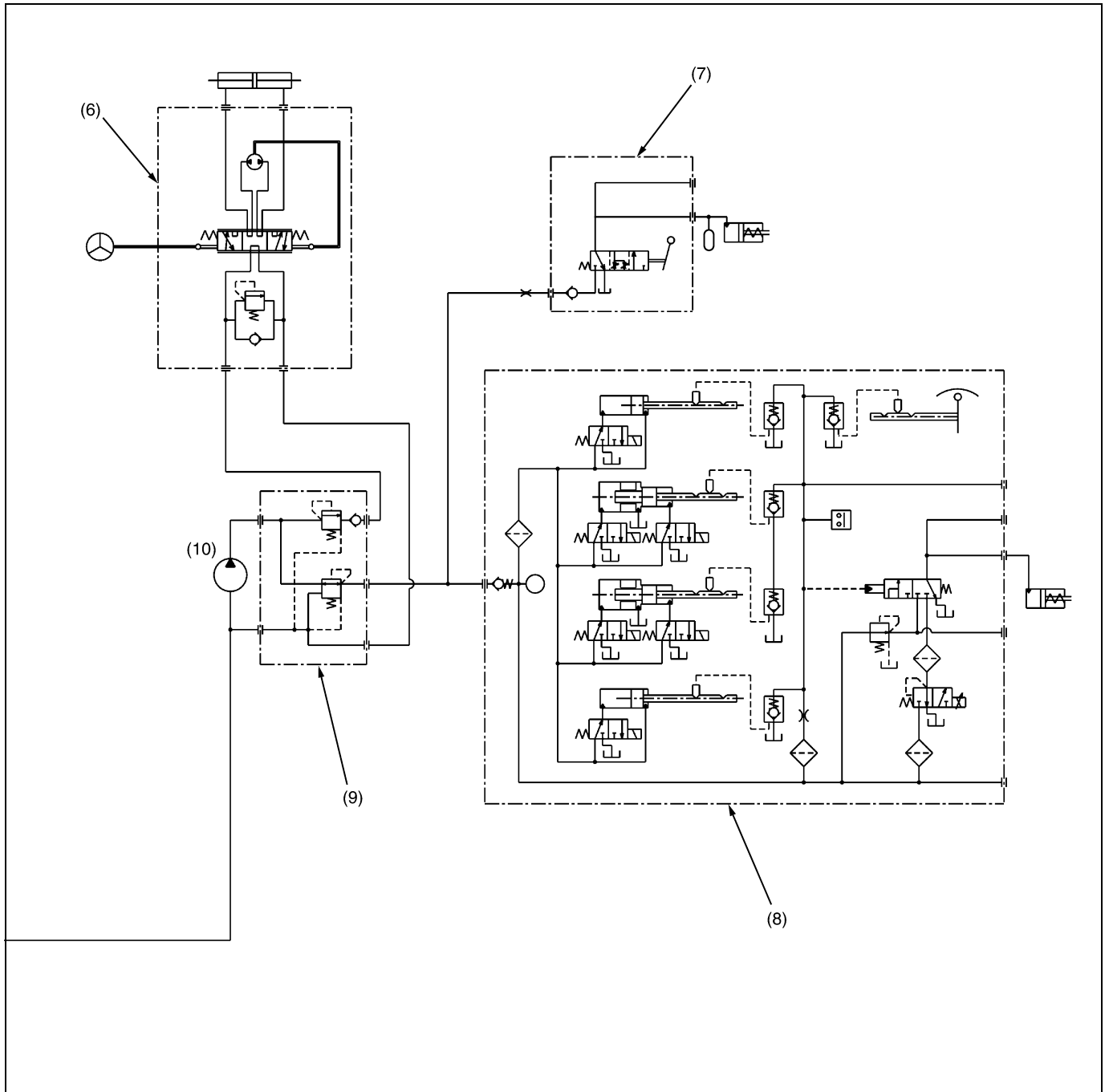

- |   |                           |                       |                            |
|---|---------------------------|-----------------------|----------------------------|
| (9) Regulator Valve (Refer to TRANSMISSION Section) | (11) Rear Hydraulic Block | (13) Hydraulic Pump 1 | (15) Front Hydraulic Block |
| (10) Hydraulic Pump 2                               | (12) Oil Filter           | (14) Relief Valve     |                            |

### [3] HYDROSTATIC TRANSMISSION

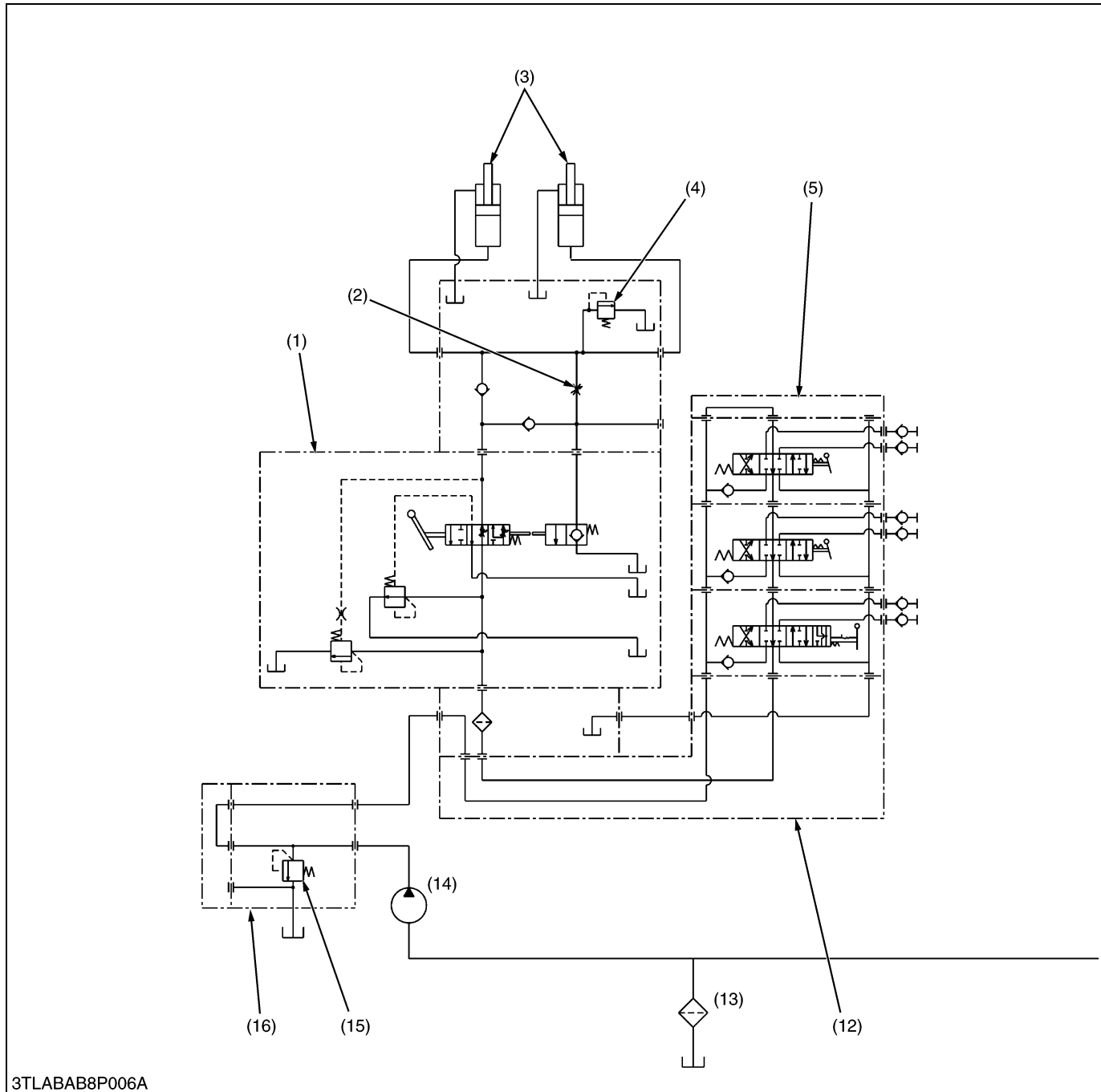

- |                                    |                           |   |   |
|------------------------------------|---------------------------|---|---|
| (1) Position Control Valve         | (3) Hydraulic Cylinder    | (5) Auxiliary Control Valve                               | (7) Hydraulic Pump 2                                |
| (2) Lowering Speed Adjusting Valve | (4) Cylinder Safety Valve | (6) Power Steering Controller (Refer to STEERING Section) | (8) Servo Regulator (Refer to TRANSMISSION Section) |



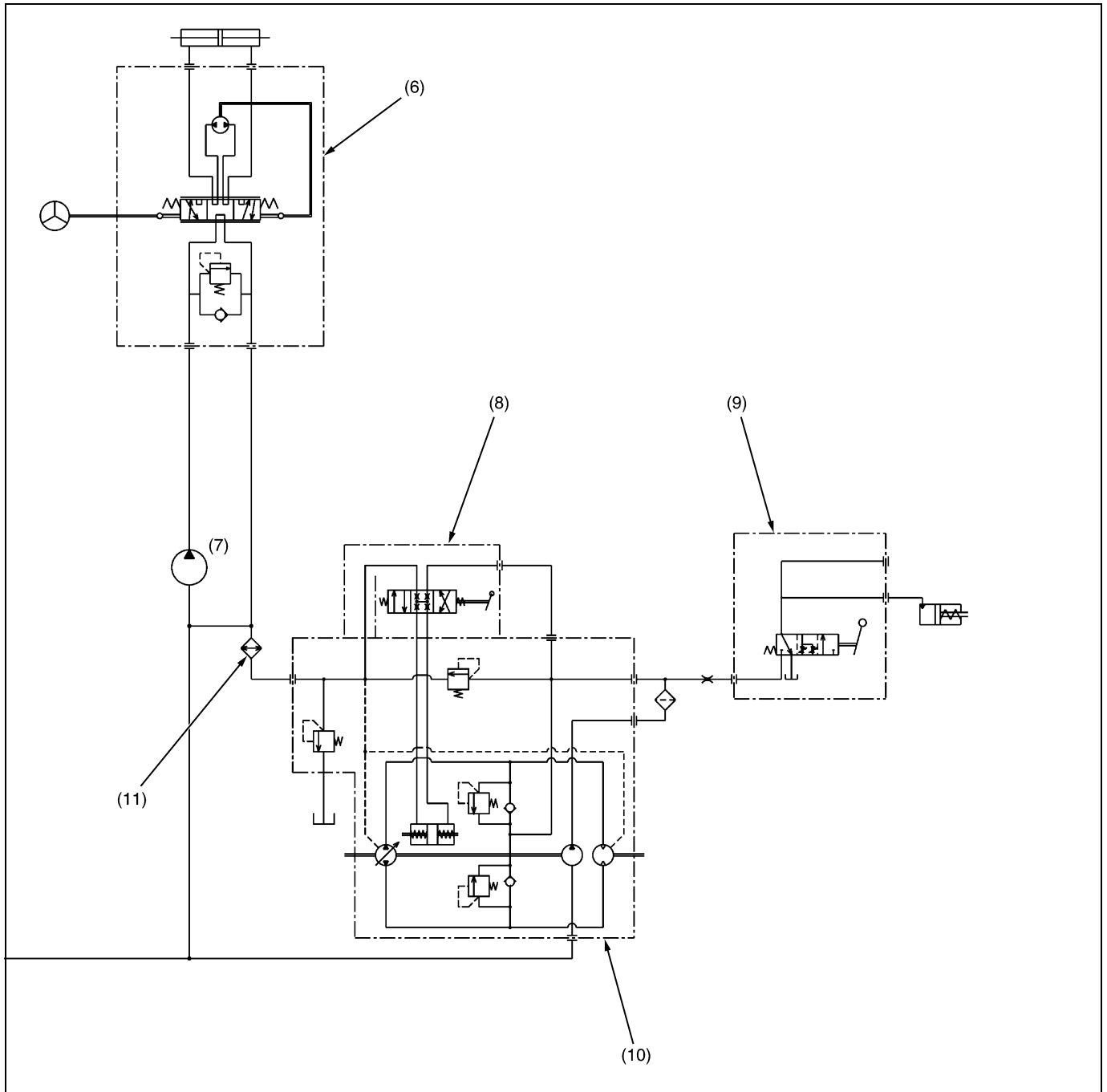

- |   |                           |                       |                            |
|---|---------------------------|-----------------------|----------------------------|
| (9) PTO Clutch Valve (Refer to TRANSMISSION Section)                | (11) Oil Cooler           | (13) Oil Filter       | (15) Relief Valve          |
| (10) Hydrostatic Transmission (HST) (Refer to TRANSMISSION Section) | (12) Rear Hydraulic Block | (14) Hydraulic Pump 1 | (16) Front Hydraulic Block |

### 3. HYDRAULIC PUMP

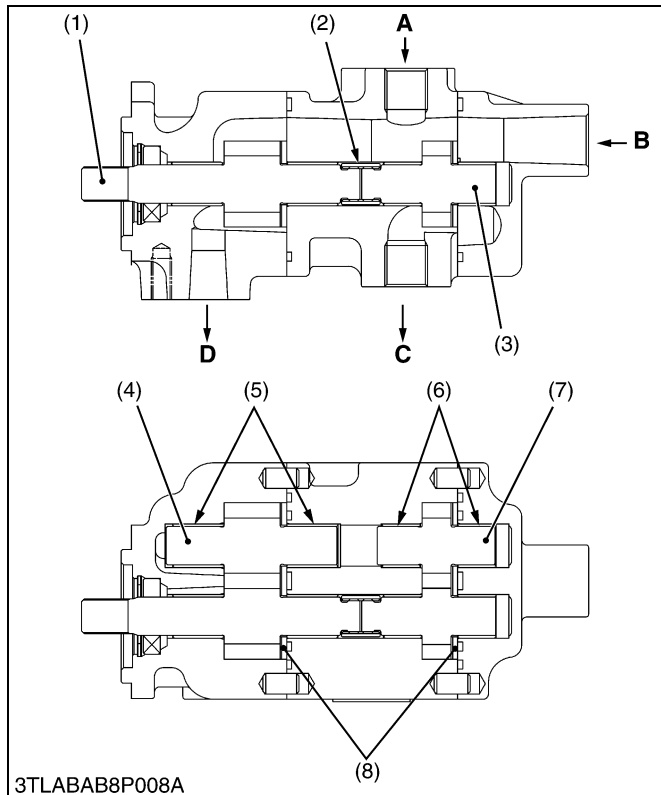

The gear type hydraulic pump is adopted for these tractor. This pump is tandem type and it is composed two pair of gears, side plates, bushings and other components as shown in the figure.

The hydraulic pump pressure-fed the oil drawn from the transmission case through oil filter to power steering circuit and main hydraulic circuit.

- (1) Drive Gear 1
- (2) Coupling
- (3) Drive Gear 2
- (4) Driven Gear 1
- (5) Bushing
- (6) Bushing
- (7) Driven Gear 2
- (8) Side Plate

**A : From Power Steering**

**Controller**

**B : From Transmission Case**

**C : To Power Steering**

**Controller**

**D : To Main Hydraulic Circuit**

W1013488

## 4. FRONT HYDRAULIC BLOCK

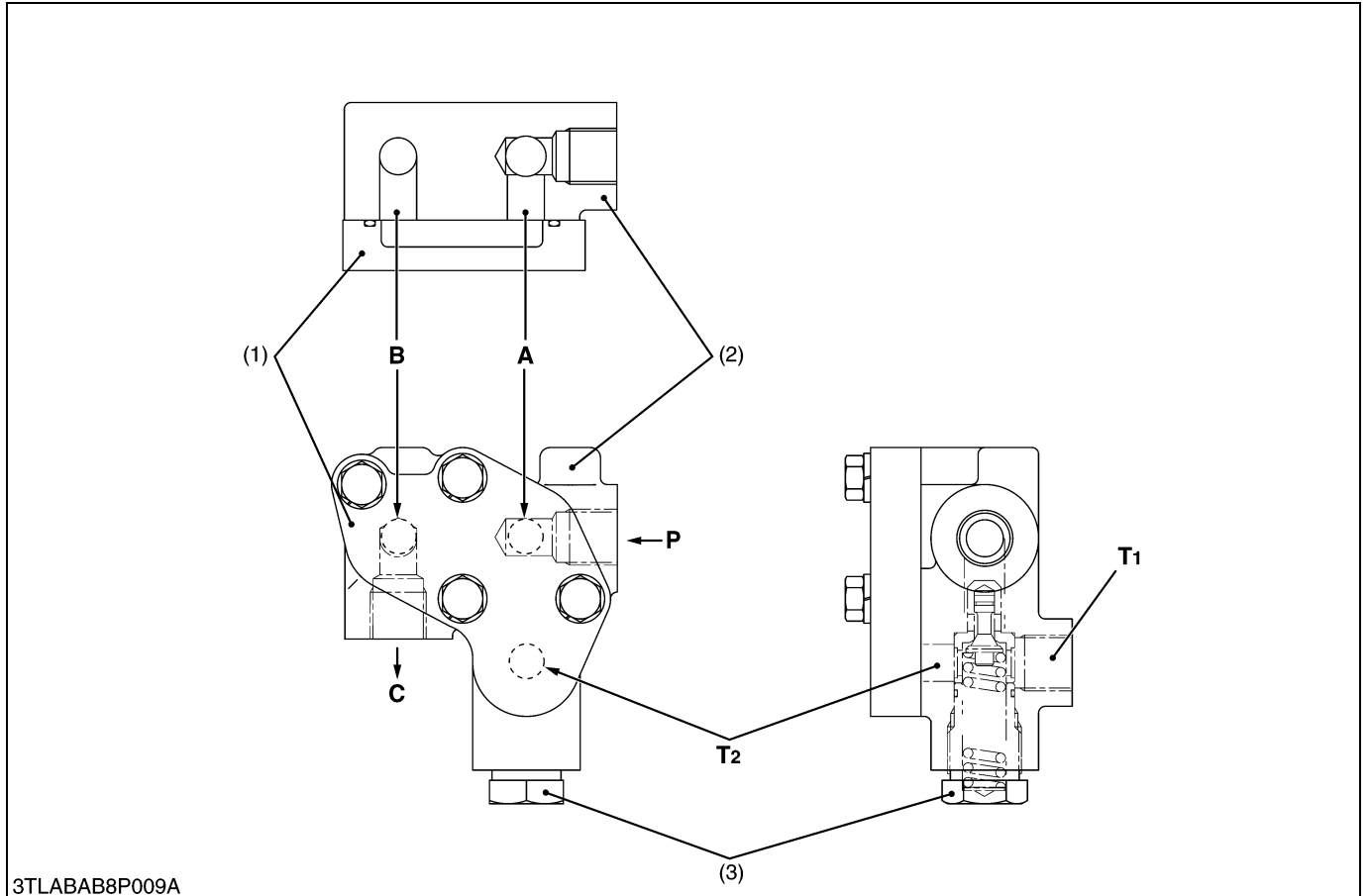

- (1) Cap  
 (2) Front Hydraulic Block  
 (3) Relief Valve

**A : To Implement Control Valve**  
**B : From Implement Control Valve**  
**C : To Position Control Valve**

**P : From Hydraulic Pump**  
**T1 : To Transmission Case**  
**T2 : From Implement Control Valve**

The front hydraulic block is provided to take power out from the tractor to operate the hydraulic cylinders on the implement, such as front end loader, front blade and so on.

## 5. REAR HYDRAULIC BLOCK

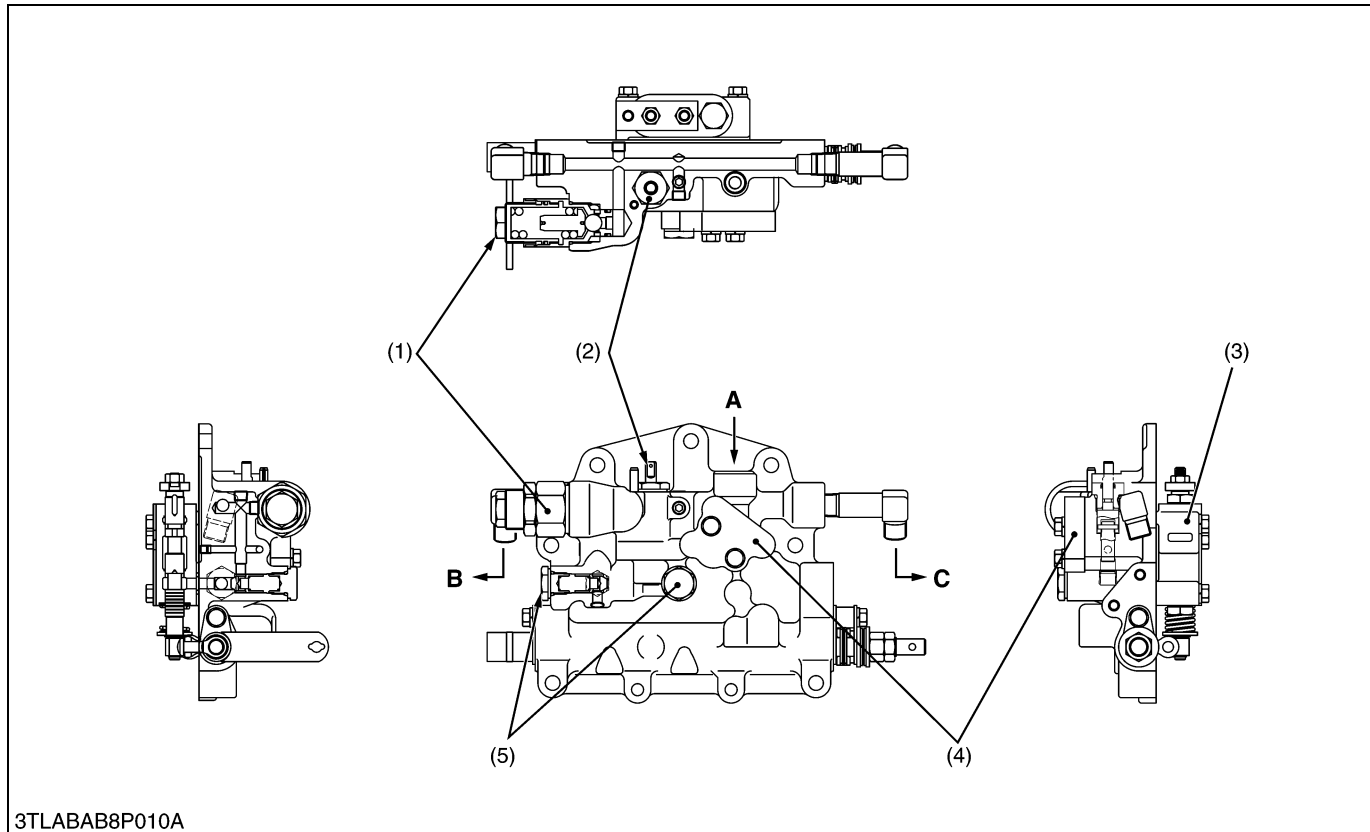

3TLABAB8P010A

- |                                    |  |                 |
|------------------------------------|--|-----------------|
| (1) Cylinder Safety Valve          | (3) Position Control Valve             | (5) Check Valve |
| (2) Lowering Speed Adjusting Valve | (4) Cover (Rear Hydraulic Outlet Port) |                 |

**A : From Hydraulic Pump**  
**B : To or From Hydraulic Cylinder**  
**C : To or From Hydraulic Cylinder**

The rear hydraulic block is equipped with cylinder safety valve, lowering speed adjusting valve and check valve, etc. besides hydraulic outlet port.

The hydraulic outlet port is located top of the rear hydraulic block to take power out from the tractor to operate the hydraulic cylinders on the implement.

## 6. POSITION CONTROL VALVE

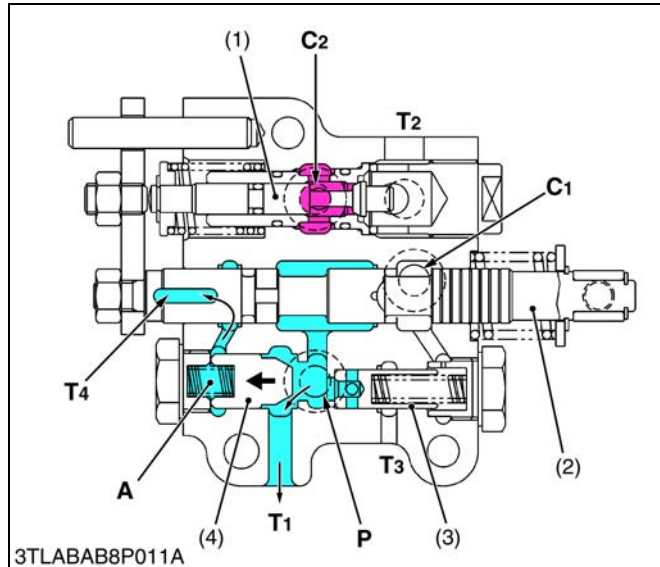

### ■ Neutral

Pressurized oil flows at the **P** port, pushes open unload poppet 1 (4) and returns to tank from **T1** port.

The oil in the chamber **A** behind the unload poppet 1 (4) returns to the tank from **T4** port. The oil in the hydraulic cylinder does not flow out because the circuit is cut off by the actions of poppet 2 (1) and check valve in the rear hydraulic block.

This allows the implement to be kept at a steady height.

- (1) Poppet 2
- (2) Spool
- (3) Unload Poppet 2
- (4) Unload Poppet 1

**P** : Pump Port  
**C1** : Cylinder Port 1  
**C2** : Cylinder Port 2  
**T1** : Tank Port 1  
**T2** : Tank Port 2  
**T3** : Tank Port 3  
**T4** : Tank Port 4

**A** : Chamber A

W1013891

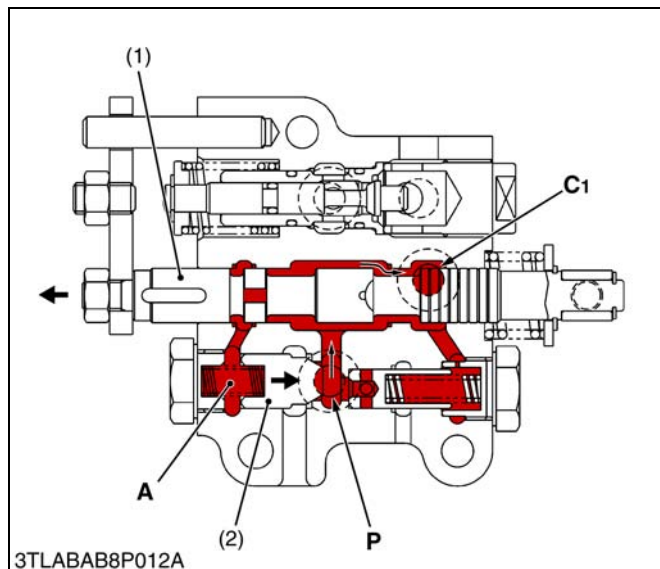

### ■ Lifting

When the control lever is moved to “**LIFT**” position, spool (1) is pushed by the spool operating lever, forming a circuit with the **P** port and chamber **A**.

The pressurized oil thus flows into the chamber **A** and closes unload poppet 1 (2).

The oil from **C1** port flows into hydraulic cylinder through check valve in the rear hydraulic block to lift the implement.

- (1) Spool
- (2) Unload Poppet 1

**P** : Pump Port  
**C1** : Cylinder Port 1

**A** : Chamber A

W1014132

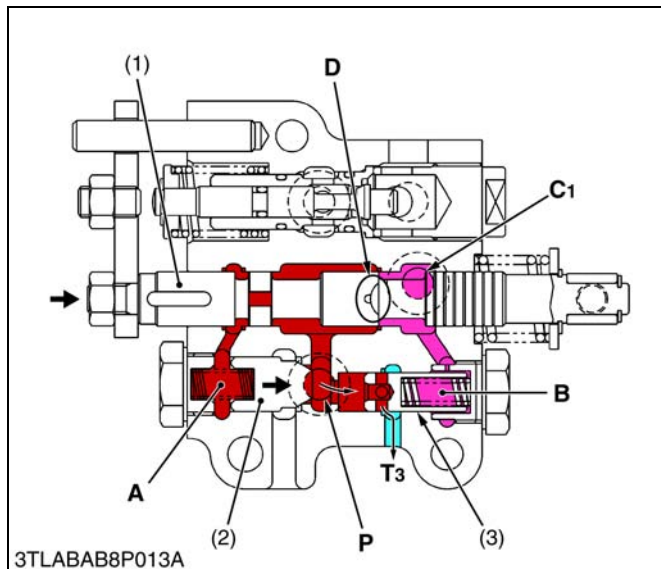

### ■ Lifting to Neutral (Acting the shockless mechanism)

In returning from **Lifting** to **Neutral**, the spool (1) is pushed back to the arrow-mark direction. When the **Neutral** position comes near, the groove part **D** of the spool (1) makes the pressure difference at the **P** port and **C1** port. Therefore, the check valve in the rear hydraulic block gradually closes, and absorbs any shock at lifting stop. In that case, since oil is remained in the chamber **A** of the unload poppet 1 (2) and closes. However, the unload poppet 2 (3) opens because of low pressure in chamber **B**, and then the oil from the pump returns to the transmission case through **T3** port until unload poppet 1 (2) opens.

- (1) Spool
- (2) Unload Poppet 1
- (3) Unload Poppet 2
- A** : Chamber A
- B** : Chamber B
- D** : Groove

- P** : Pump Port
- C1** : Cylinder Port 1
- T3** : Tank Port 3

W1014273

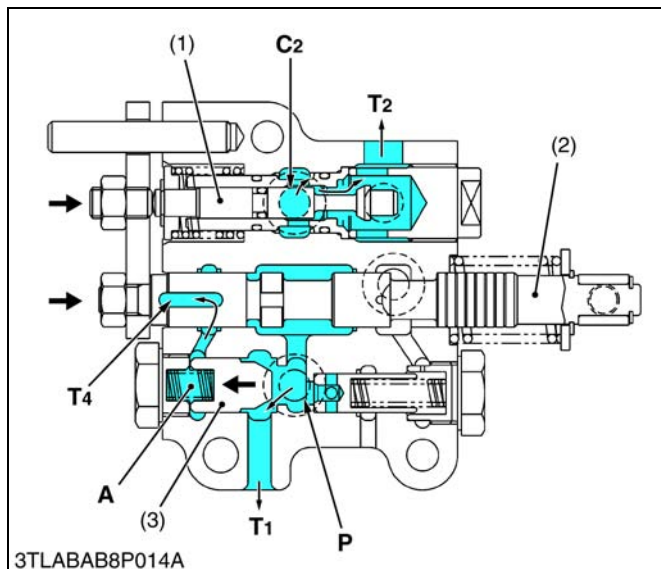

### ■ Lowering

When the control lever is moved to “**DOWN**” position, spool (2) moves to arrow-mark direction, and pushes the poppet 2 (1). It forms a circuit with the **C2** port and **T2** port.

The oil in the hydraulic cylinder is forced out by the weight of the implement, and returns to the tank through the **C2** port and **T2** port, lowering the implement.

The pressurized oil at the **P** port pushes open unload poppet 1 (3) and returns to tank from **T1** port.

### ■ Floating

When the control lever is moved all the way to the bottom, spool (2) and poppet 2 (1) remain in the position described for “**Lowering**”. The oil flows freely between the hydraulic pump, hydraulic cylinder and tank.

- (1) Poppet 2
- (2) Spool
- (3) Unload Poppet 1

**A** : Chamber A

- P** : Pump Port
- C2** : Cylinder Port 2
- T1** : Tank Port 1
- T2** : Tank Port 2
- T4** : Tank Port 4

W1014640



## 7. POSITION CONTROL LINKAGE

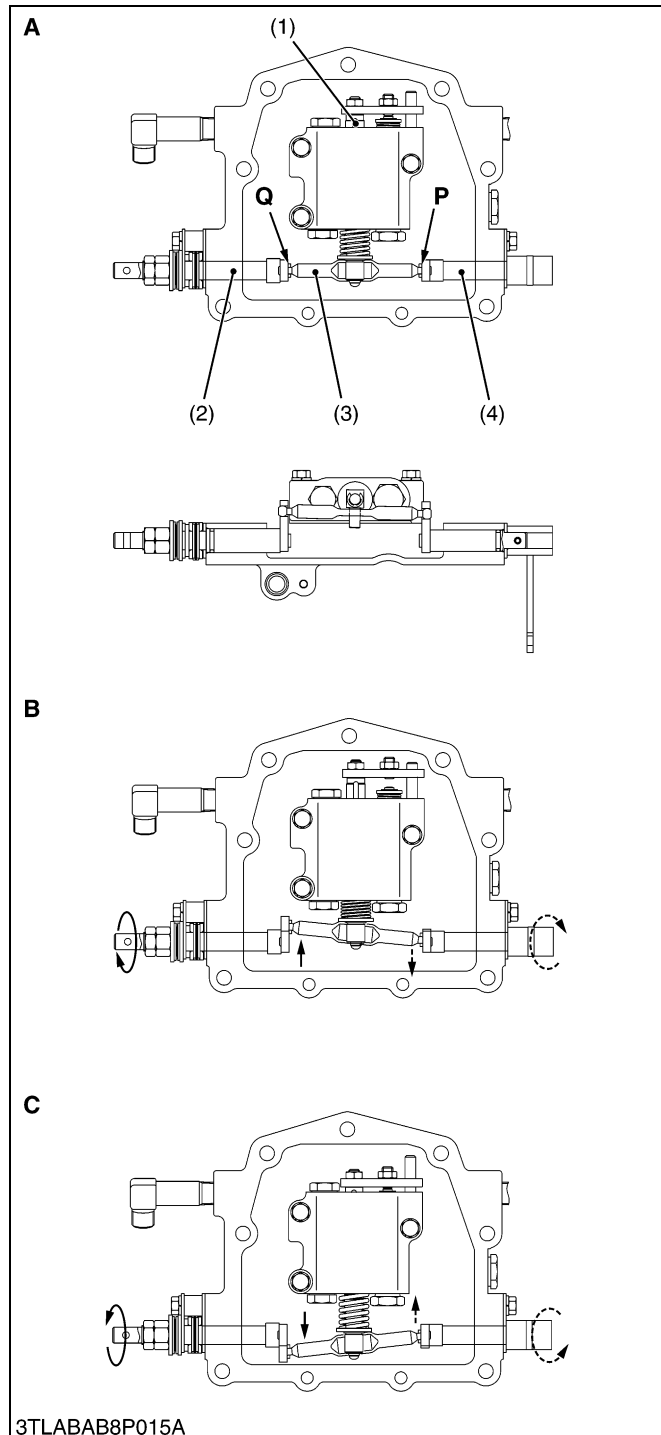

Position control is a mechanism to raise or lower the implement attached to the tractor in proportion to the movement of the control lever.

The implement can be positioned at any height by moving the position control lever. Fine position adjustment is also easy.

### ■ Lift

1. When the position control lever is moved to the **LIFT** position, the control arm shaft (2) rotates to the arrow. Therefore, the spool drive lever (3) moves around the fulcrum **P** and push the spool (1) opening the **LIFT** circuit.
2. When the lift arm moves upward, the feedback lever shaft (4) is rotated to the arrow, since the feedback rod is actuated. Therefore, the spool drive lever (3) moves around the fulcrum **Q** and pull the spool (1).
3. The lift arm stops when the spool returns to the neutral position.

### ■ Down

1. When the position control lever is moved to the **DOWN** position, the control arm shaft (2) rotates to the arrow. Therefore, the spool drive lever (3) moves around the fulcrum **P** and pull the spool (4) opening the **DOWN** circuit.
2. When the lift arm moves downward, the feedback lever shaft (4) is rotated to the arrow, since the feedback rod is actuated. Therefore, the spool drive lever (3) moves around the fulcrum **Q** and pushes the spool (1).
3. The lift arm stops when the spool (1) returns to the neutral position.

- (1) Spool
- (2) Control Arm Shaft
- (3) Spool Drive Lever
- (4) Feedback Lever Shaft

**A : Neutral**

**B : Lift**

**C : Down**

W1014898

## 8. POSITION CONTROL WITH DRAFT CONTROL LINKAGE

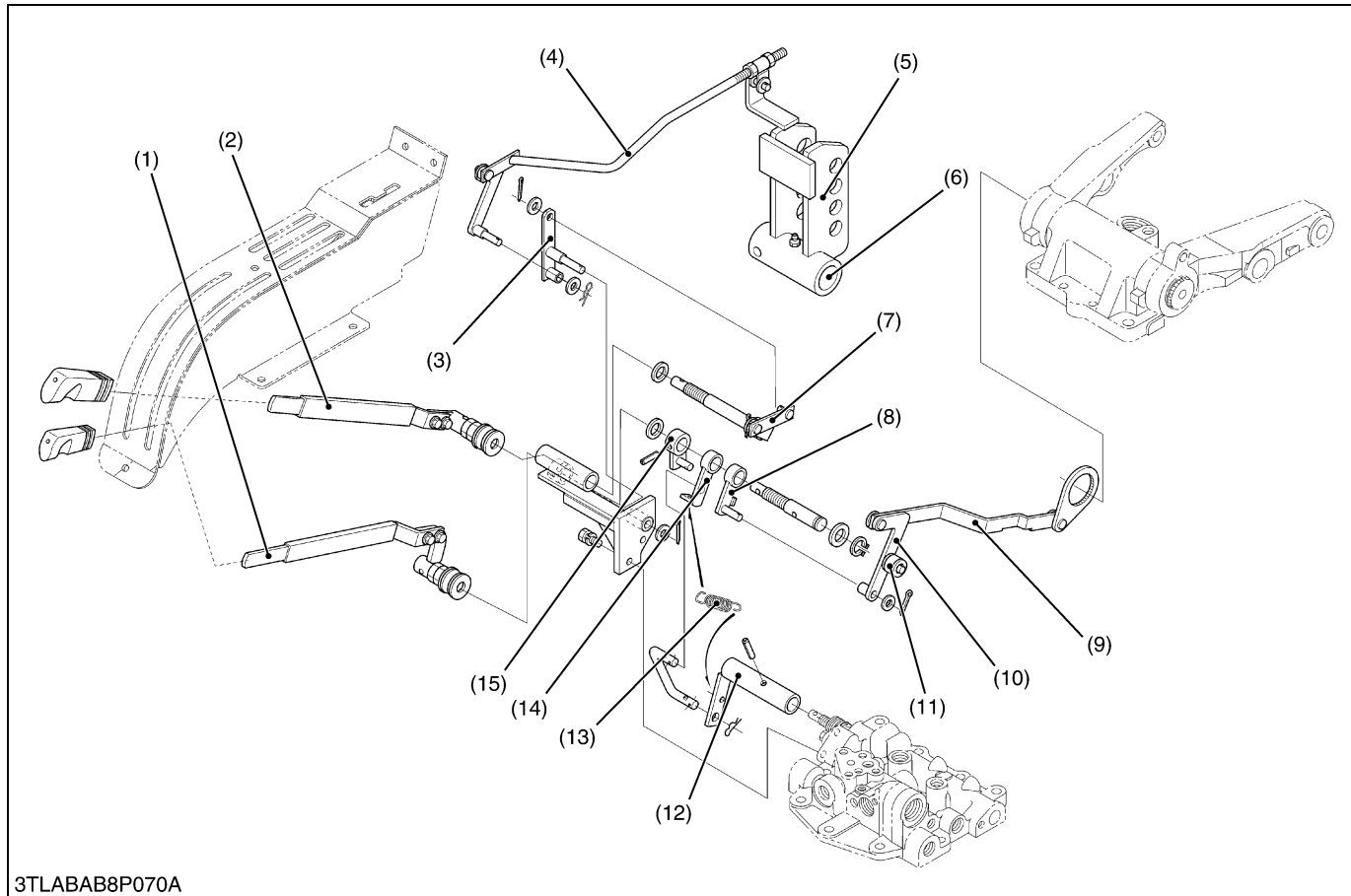

- |                            |                          |                           |                            |
|----------------------------|--------------------------|---------------------------|----------------------------|
| (1) Position Control Lever | (5) Top Link Bracket     | (9) Feedback Rod          | (13) Return Spring         |
| (2) Draft Control Lever    | (6) Torsion Bar          | (10) Draft Control Link 2 | (14) Arm 1                 |
| (3) Draft Control Link 3   | (7) Draft Control Link 4 | (11) Roller               | (15) Position Control Link |
| (4) Draft Control Rod      | (8) Draft Control Link 1 | (12) Arm 2                |                            |

Draft control is a system which maintains a constant traction load, and is suited for the work which needs heavy traction load such as plowing.

The implement is automatically raised when its traction load is increased, and lowers when the traction load is decreased. By maintaining a constant load level, it prevents the tractor from slipping and being loaded excessively. The setting traction load can be adjusted by changing the position of the draft control lever.

The draft control system uses the same control valve as the position control system. Therefore it is possible to use the mixed control. The traction load applied to the tractor is sensed and is fed back to the control valve by means of the other linkage mechanism.

## ■ Position Control Operation

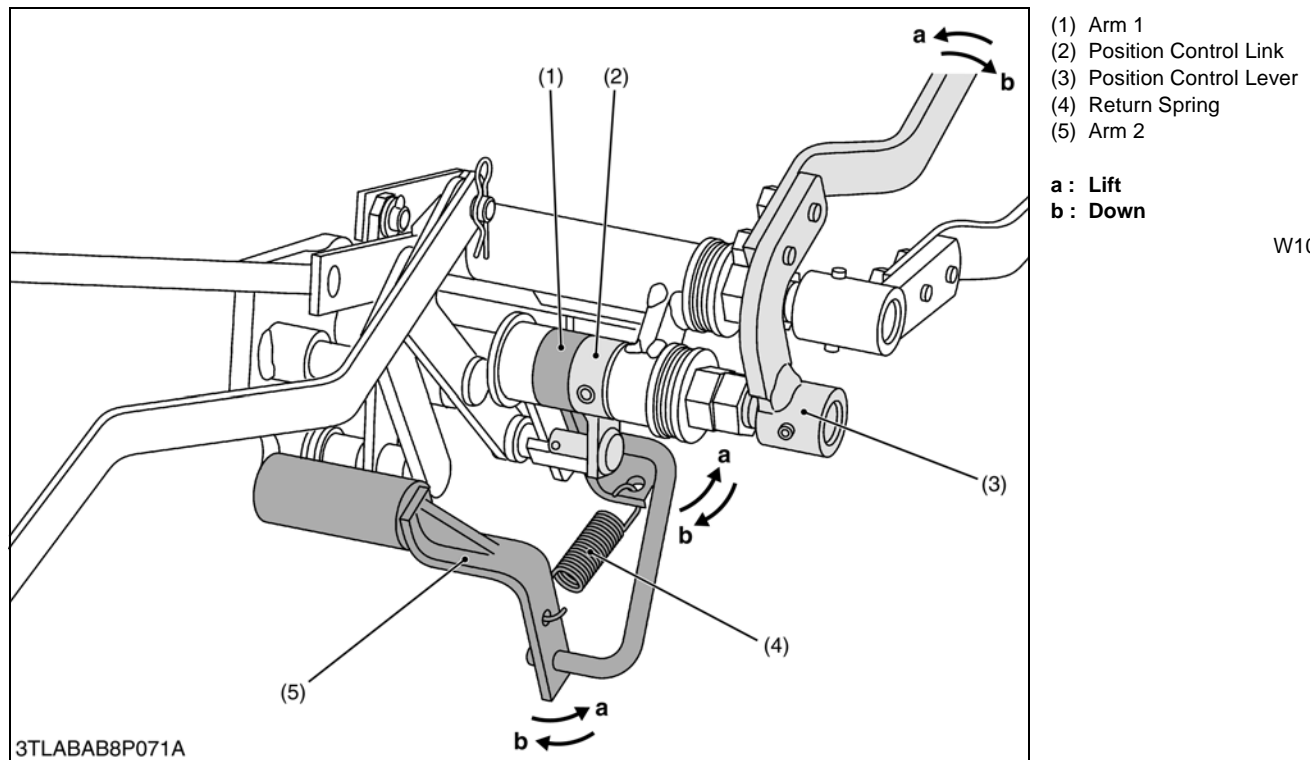

W1016226

### ● Lift (a)

1. When the position control lever (3) is moved to the **LIFT** side, the position control link (2) is also rotated and pushes the arm 1 (1).
2. At the same time, the arm 2 (5) is moved, the connected position control valve becomes the lift circuit, and the lift arm goes up.

### ● Down (b)

1. When the position control lever (3) is moved to the **DOWN** side, the position control link (2) is also rotated.
2. By this action, the arm 2 (5) and the arm 1 (1) are returned by the return spring (4).
3. The position control valve becomes the down circuit and the lift arm is lowered.

### (Reference)

- For the feedback mechanism of the position control, refer to “**Position Control**”.

## ■ Draft Control Operation

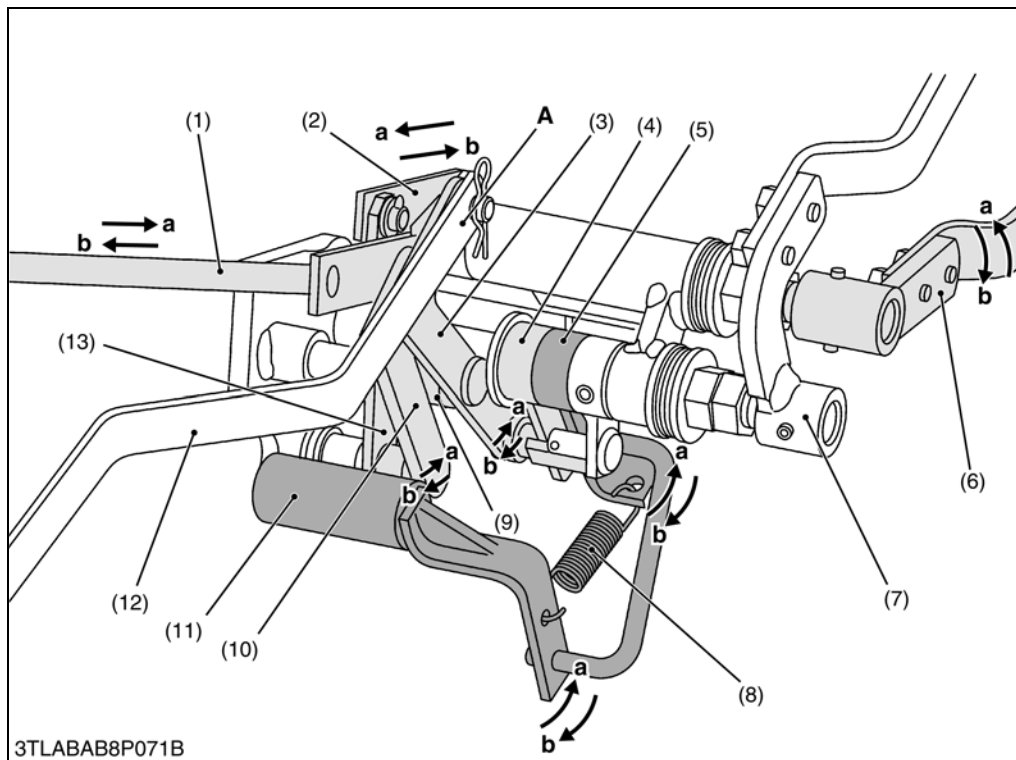

- (1) Draft Control Rod  
(Connected to Top Link  
Bracket)
- (2) Draft Control Link 4
- (3) Draft Control Link 2
- (4) Draft Control Link 1
- (5) Arm 1
- (6) Draft Control Lever
- (7) Position Control Lever
- (8) Return Spring
- (9) Roller
- (10) Draft Cam
- (11) Arm 2
- (12) Feedback Rod (Connected  
to Lift Arm)
- (13) Draft Control Link 3

**a : Lift**  
**b : Down**

W1016549

When the draft control lever (6) is operated in the draft control operated range, the draft control lever shaft is rotated, causing the draft cam (10) to move toward the roller (9) installed on the draft control link 2 (3).

### (Reference)

- The sensitivity of the draft control can be adjusted by changing the gap between the draft cam (10) and the roller (9) by the draft control lever (6).

### ■ Movement of the Link Under Increased Load (a)

1. When the traction load is increased, the torsion bar is twisted according to the load, the draft control rod (1) and the draft cam (10) are pushed to come into contact with the roller (9).
2. Using the **A** portion as the fulcrum, the draft control link 2 (3) and the draft control link 1 (4) move to push the arm 1 (5).
3. At the same time, the arm 2 (11) is moved, the connected position control valve becomes the lift circuit, and the lift arm goes up.

### ■ Movement of the Link Under Decreased Load (b)

1. When the lift arm goes up, the traction load is decreased, and the draft control rod (1) is returned.
2. At the same time, the arm 2 (11), arm 1 (5), and draft control link 1 (4) are returned by the return spring (8).
3. The position control valve becomes the down circuit, and the lift arm is lowered.

### (Reference)

- The feedback rod (12) of the draft control is provided to maintain the position relation of the draft cam (10) and the roller (9) to certain state regardless of the height of the lift arm.

## 9. MIXED CONTROL

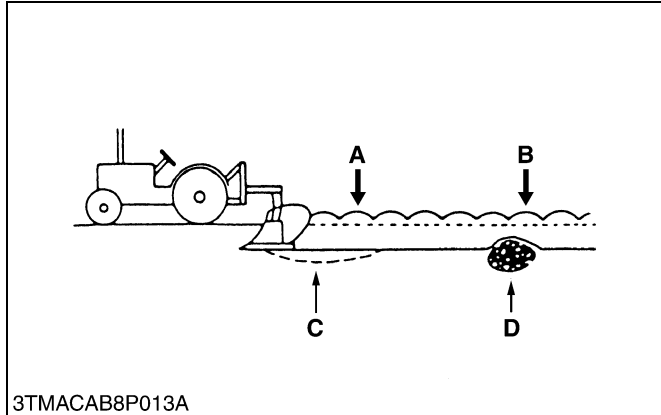

Mixed control is a system combining position control with draft control.

When traction load increases, the draft control functions to raise the lift arms (implement). When traction load reduces, the lift arms (implement) lower to the height set by the position control only, when traction load increases, slippage or engine stop may occur unless the implement is raised.

With the draft control only, plowing depth cannot be kept constant if soil hardness changes greatly.

The mixed control serves to eliminate such disadvantages.

- |                                       |  |
|---------------------------------------|--|
| <b>A : Position Controlled</b>        | <b>D : Shallow where Resistance Occurs</b> |
| <b>B : Draft Controlled</b>           |  |
| <b>C : Not Deep Even in Soft Soil</b> |  |

W1017580

## 10. LOWERING SPEED ADJUSTING VALVE

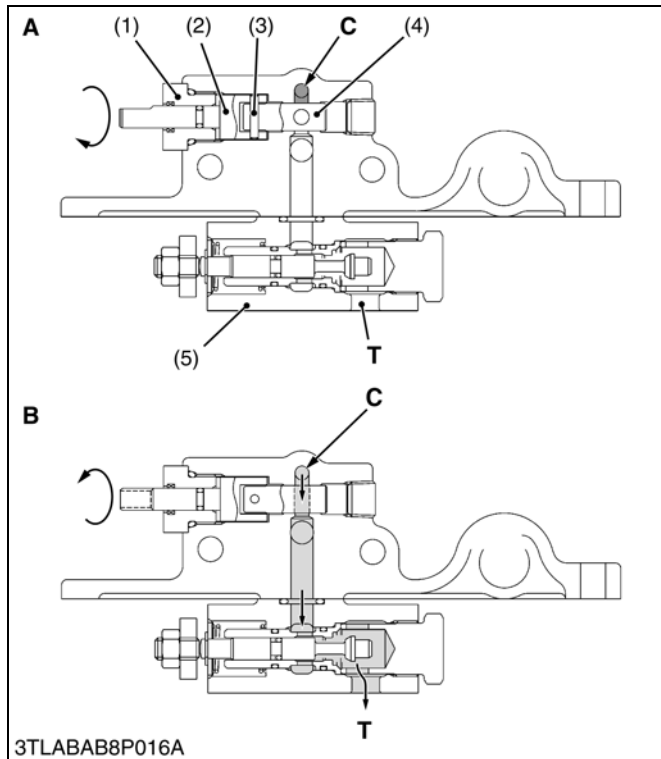

Turning the rotor shaft (2) clockwise decreases the lowering speed, and counterclockwise increases lowering speed of the three points linkage. When the rotor shaft (2) is completely closed, the three point linkage is held at its position since oil in the hydraulic cylinder is sealed between the hydraulic cylinder and rotor (4).

- (1) Holder
- (2) Rotor Shaft
- (3) Pin
- (4) Rotor
- (5) Position Control Valve

- A : Closed Position**
- B : Open Position**
- C : Cylinder Port**
- T : Tank Port**

W1015173



# 11. HYDRAULIC CYLINDER

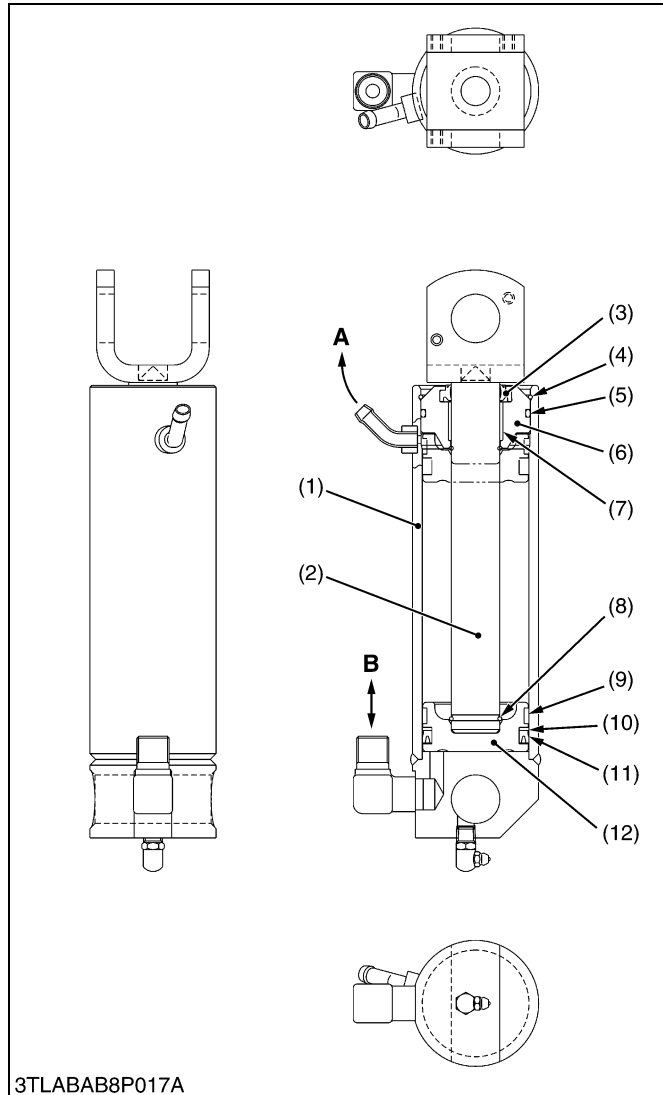

3TLABAB8P017A

The external type hydraulic cylinders are used for three point linkage system. This hydraulic cylinder is single acting type, and it is installed directly between hydraulic lift arm and lower link.

The main components of the hydraulic cylinder are shown in the figure.

- |                   |                  |
|-------------------|------------------|
| (1) Cylinder Tube | (9) Bearing Ring |
| (2) Rod           | (10) Backup Ring |
| (3) Wiper         | (11) Seal        |
| (4) Snap Ring     | (12) Piston      |
| (5) O-ring        |                  |
| (6) Head          |                  |
| (7) Bushing       |                  |
| (8) Snap Ring     |                  |

**A : To Transmission Case**  
**B : To or From Position**  
**Control Valve**

W1015282

# 12. AUXILIARY CONTROL VALVE

## [1] DOUBLE ACTING TYPE 1

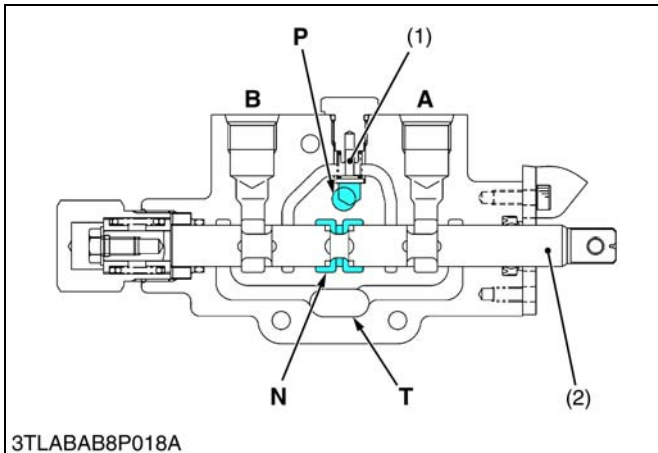

### ■ Neutral

Pressure-fed oil from the hydraulic pump is delivered into the **P** port, and flows to the position control valve via **N** port.

- |  |                         |
|--|-------------------------|
| (1) Check Valve                        | <b>P : Pump Port</b>    |
| (2) Spool                              | <b>N : Neutral Port</b> |
| <b>A : A Port (Implement Cylinder)</b> | <b>T : Tank Port</b>    |
| <b>B : B Port (Implement Cylinder)</b> |                         |

W1015469

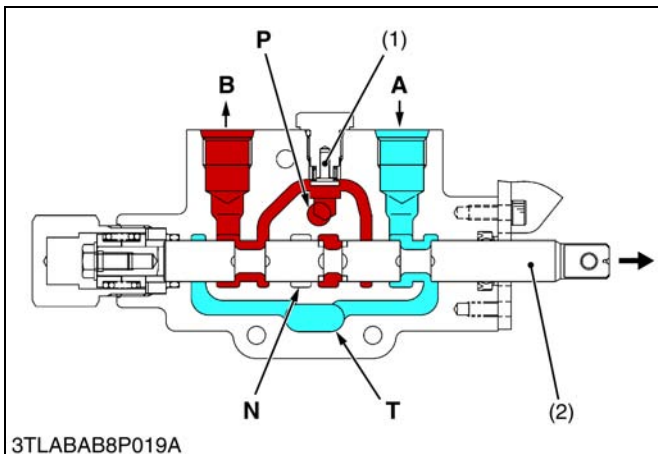

### ■ Lift

When the spool (2) is moved in the direction of the arrow, the pressure-fed oil in the **P** port opens the check valve (1) and flows to the implement cylinder via **B** port.

Return oil from the implement cylinder flows from the **A** port to the transmission case through **T** port.

- |  |                         |
|--|-------------------------|
| (1) Check Valve                        | <b>P : Pump Port</b>    |
| (2) Spool                              | <b>N : Neutral Port</b> |
| <b>A : A Port (Implement Cylinder)</b> | <b>T : Tank Port</b>    |
| <b>B : B Port (Implement Cylinder)</b> |                         |

W1015571

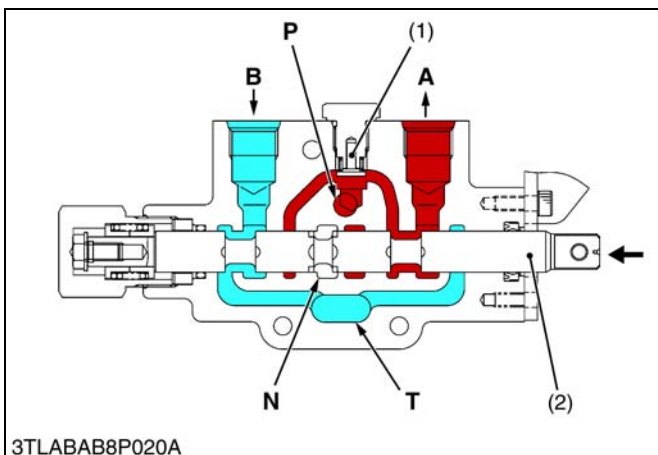

### ■ Down

When the spool (2) is moved in the direction of the arrow, the pressure-fed oil in the **P** port opens the check valve (1) and flows to the implement cylinder via **A** port.

Return oil from the implement cylinder flows from the **B** port to the transmission case through **T** port.

- |  |                         |
|--|-------------------------|
| (1) Check Valve                        | <b>P : Pump Port</b>    |
| (2) Spool                              | <b>N : Neutral Port</b> |
| <b>A : A Port (Implement Cylinder)</b> | <b>T : Tank Port</b>    |
| <b>B : B Port (Implement Cylinder)</b> |                         |

W1015748

## [2] DOUBLE ACTING TYPE 2 (FLOATING WITH DETENT)

### ■ Neutral

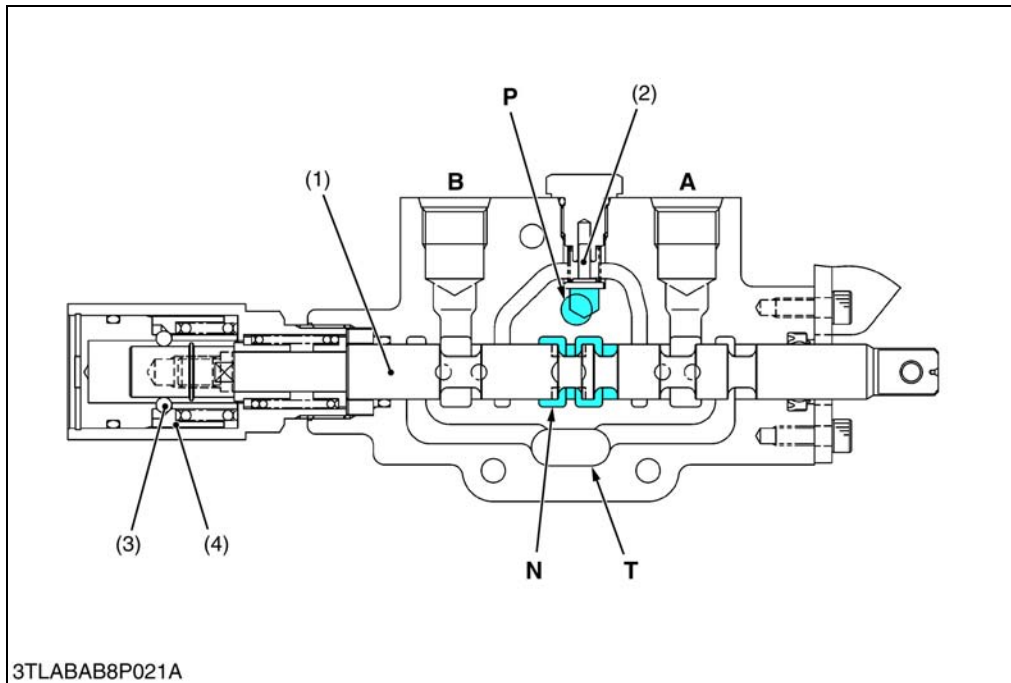

- (1) Spool
- (2) Check Valve
- (3) Detent Ball
- (4) Detent Sleeve

**A : A Port  
(Implement Cylinder)**  
**B : B Port  
(Implement Cylinder)**  
**P : Pump Port**  
**N : Neutral Port**  
**T : Tank Port**

W1015904

3TLABAB8P021A

Pressure-fed oil from the hydraulic pump is delivered into the **P** port, and flows to the position control valve via **N** port.

### ■ Lift

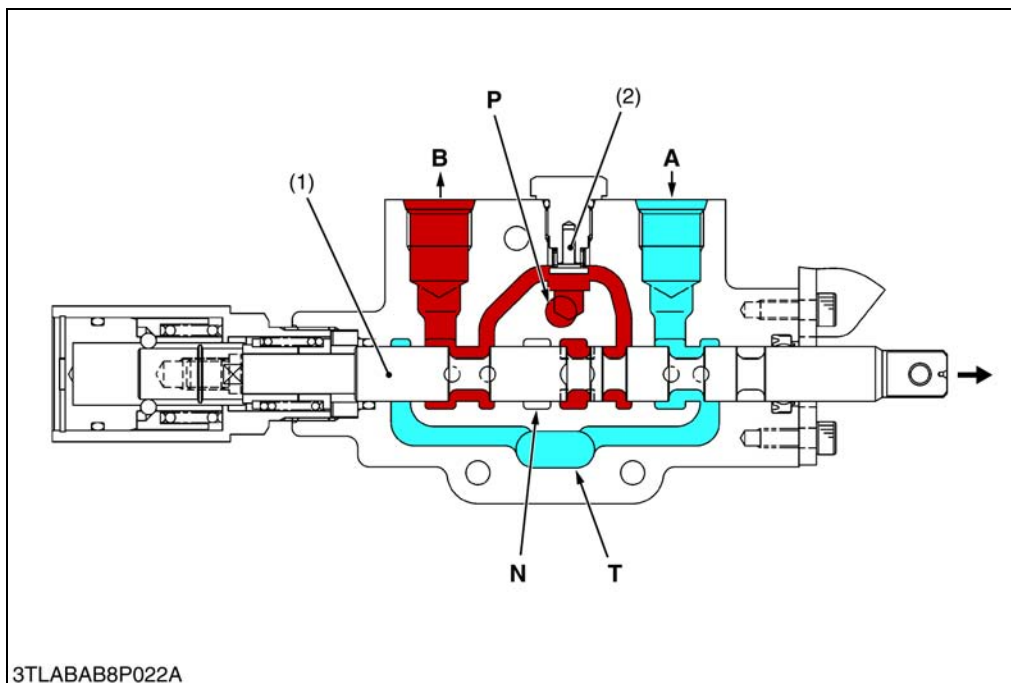

- (1) Spool
- (2) Check Valve

**A : A Port  
(Implement Cylinder)**  
**B : B Port  
(Implement Cylinder)**  
**P : Pump Port**  
**N : Neutral Port**  
**T : Tank Port**

W1016058

3TLABAB8P022A

When the spool (1) is moved in the direction of the arrow, the pressure-fed oil in the **P** port opens the check valve (2) and flows to the implement cylinder via **B** port.

Return oil from the implement cylinder flows from the **A** port to the transmission case through **T** port.

### Down

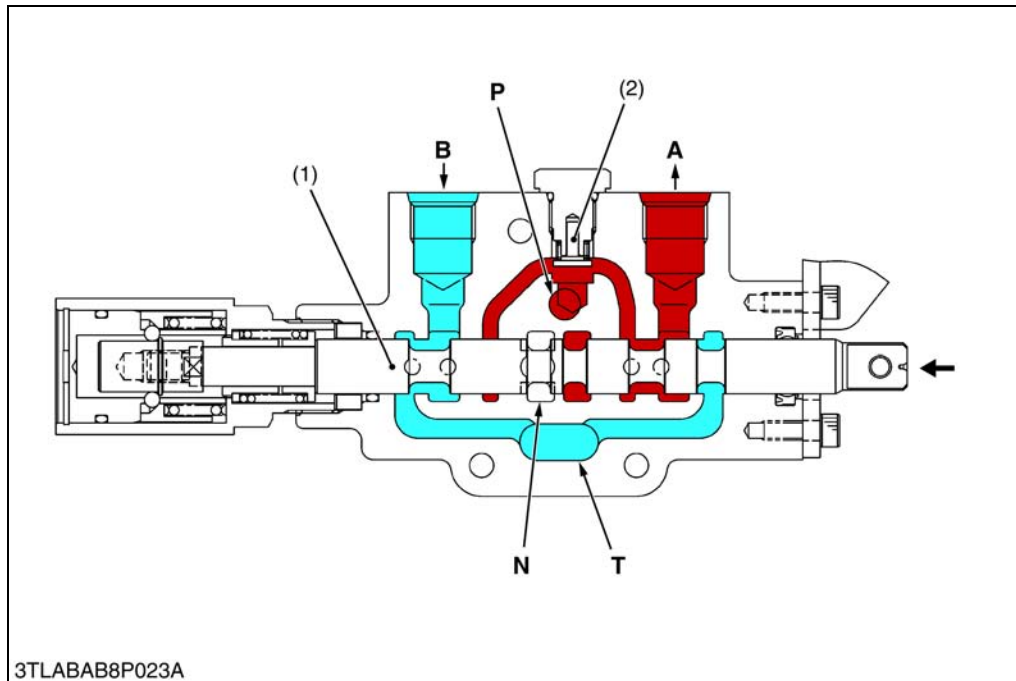

- (1) Spool
- (2) Check Valve

**A : A Port  
(Implement Cylinder)**  
**B : B Port  
(Implement Cylinder)**  
**P : Pump Port**  
**N : Neutral Port**  
**T : Tank Port**

W1016237

When the spool (1) is moved in the direction of the arrow, the pressure-fed oil in the **P** port opens the check valve (2) and flows to the implement cylinder via **A** port.

Return oil from the implement cylinder flows from the **B** port to the transmission case through **T** port.

### Floating

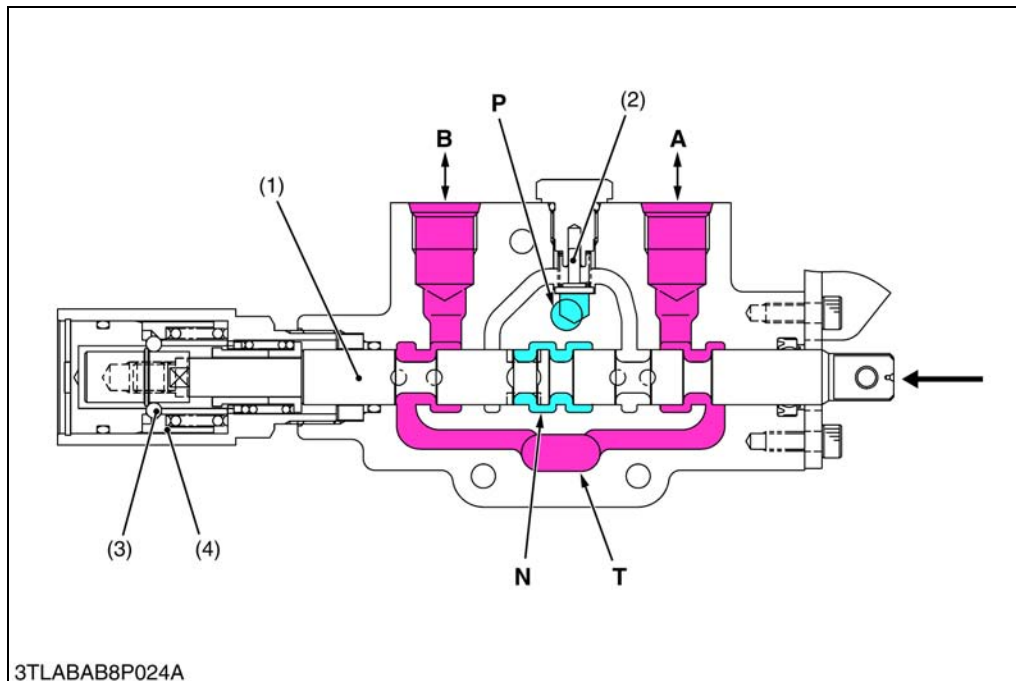

- (1) Spool
- (2) Check Valve
- (3) Detent Ball
- (4) Detent Sleeve

**A : A Port  
(Implement Cylinder)**  
**B : B Port  
(Implement Cylinder)**  
**P : Pump Port**  
**N : Neutral Port**  
**T : Tank Port**

W1016319

When the spool (1) moves to extreme left, the detent ball (3) and detent sleeve (4) hold the spool (1) at the floating position as shown in the figure. The pressure-fed oil from the hydraulic pump flows to position control valve via **N** port. And, the **A** port and **B** port lead to the **T** port along the notched sections of the spool (1). This result in the attached implement to follow the contour of the terrain.

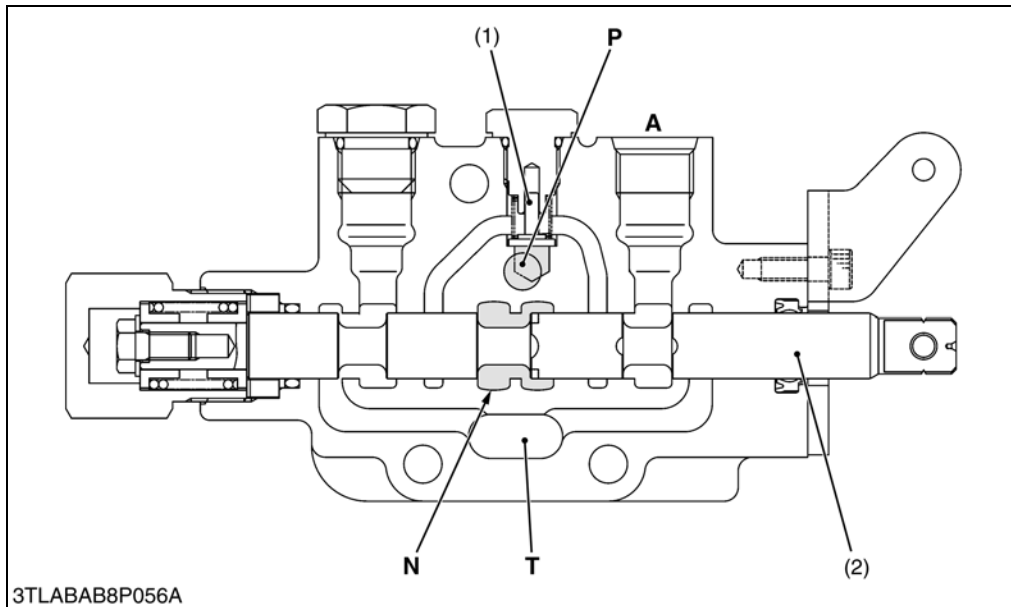
**[3] SINGLE ACTING TYPE****■ Neutral**

- (1) Check Valve  
(2) Spool

**A** : A Port  
(Implement Cylinder)  
**P** : Pump Port  
**N** : Neutral Port  
**T** : Tank Port

3TLABAB8P056A

Pressure-fed oil from the hydraulic pump is delivered into the **P** port, and flows to the position control valve via **N** port.

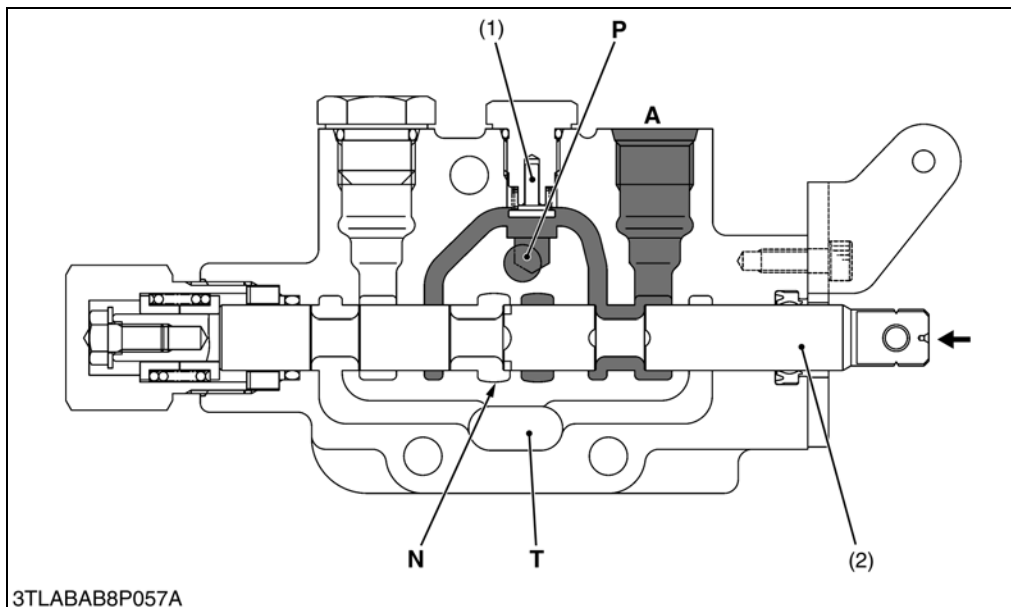
**■ Lift**

- (1) Check Valve  
(2) Spool

**A** : A Port  
(Implement Cylinder)  
**P** : Pump Port  
**N** : Neutral Port  
**T** : Tank Port

3TLABAB8P057A

When the spool (2) is moved in the direction of the arrow, the pressure-fed oil in the **P** port opens the check valve (1) and flows to the implement cylinder via **A** port.

## ■ Down

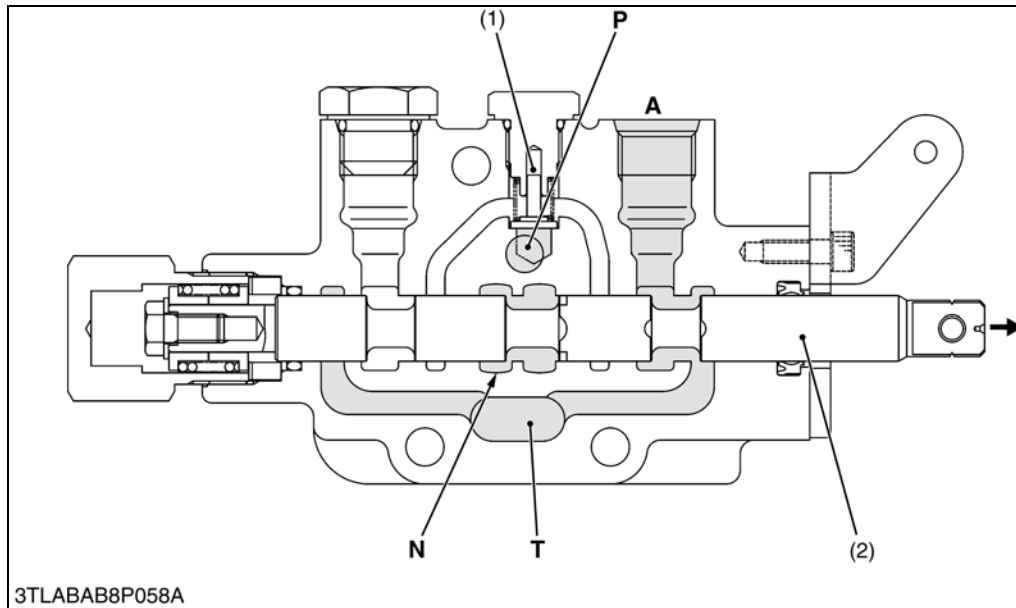

When the spool (2) is moved in the direction of the arrow, return oil from the implement cylinder flows from the **A** port.



# SERVICING

## CONTENTS

1. TROUBLESHOOTING .....	8-S1
2. SERVICING SPECIFICATIONS .....	8-S2
3. TIGHTENING TORQUES .....	8-S4
4. CHECKING, DISASSEMBLING AND SERVICING.....	8-S5
[1] HYRAULIC PUMP.....	8-S5
(1) Checking.....	8-S5
(2) Disassembling and Assembling.....	8-S7
(3) Servicing .....	8-S9
[2] RELIEF VALVE .....	8-S11
(1) Checking and Adjusting .....	8-S11
(2) Disassembling and Assembling.....	8-S11
[3] REAR HYDRAULIC BLOCK AND VALVES.....	8-S12
(1) Checking and Adjusting .....	8-S12
(2) Disassembling and Assembling.....	8-S14
(3) Servicing .....	8-S18
[4] LIFT ARM SUPPORT AND HYDRAULIC CYLINDER.....	8-S18
(1) Disassembling and Assembling.....	8-S18
(2) Servicing .....	8-S21

# 1. TROUBLESHOOTING

Symptom	Probable Cause	Solution	Reference Page
<b>Implement Does Not Rise (Not Noise)</b>	<ul style="list-style-type: none"> <li>Control linkage improperly adjusted</li> <li>Control linkage improperly assembled or damaged</li> <li>Position control valve malfunctioning</li> </ul>	Adjust Repair or replace  Repair or replace	8-S12 –  8-S15 to S17
<b>(Noise)</b>	<ul style="list-style-type: none"> <li>Relief valve spring weaken or broken</li> <li>Hydraulic piston O-ring, cylinder damaged</li> <li>Transmission fluid improper or insufficient</li> <li>Oil filter clogged</li> <li>Suction pipe loosen or broken</li> <li>Relief valve setting pressure too low</li> <li>Relief valve spring weaken or damaged</li> <li>Hydraulic pump malfunctioning</li> </ul>	Replace Replace  Change or replenish Replace Repair or replace Adjust Replace Repair pr replace	8-S11 8-S19  G-7, 8 G-16 – 8-S11 8-S11 8-S7 to S10
<b>Implement Does Not Reach Maximum Height</b>	<ul style="list-style-type: none"> <li>Position control feedback rod improperly adjusted</li> <li>Top link length improperly adjusted</li> <li>Hydraulic arm shaft, lift arm improperly assembled</li> <li>3 point link improperly set</li> </ul>	Adjust  Adjust Adjust Adjust	8-S12 – 8-S20 –
<b>Implement Does Not Lower</b>	<ul style="list-style-type: none"> <li>Position control valve malfunctioning               <ul style="list-style-type: none"> <li>- Spool damaged</li> <li>- Poppet 2, push rod improperly adjusted</li> </ul> </li> </ul>	Replace Adjust	8-S17 8-S17
<b>Implement Drops by Weight</b>	<ul style="list-style-type: none"> <li>Hydraulic cylinder worn or damaged</li> <li>Safety valve damaged</li> <li>Hydraulic piston and O-ring worn or damaged</li> <li>Lowering speed adjusting valve damaged</li> <li>Position control valve malfunctioning               <ul style="list-style-type: none"> <li>- Poppet 2 seat surface damaged</li> <li>- Poppet 2 seat sleeve O-ring damaged</li> </ul> </li> </ul>	Replace Replace Replace Replace  Replace Replace	8-S19 8-S16 8-S19 8-S15  8-S17 8-S17
<b>Implement Hunts (Moves Up and Down)</b>	<ul style="list-style-type: none"> <li>Position control valve malfunctioning               <ul style="list-style-type: none"> <li>- Poppet 2 seat surface damaged</li> <li>- Poppet 2 seat sleeve O-ring damaged</li> </ul> </li> <li>Poppet 2, push rod improperly adjusted</li> </ul>	Replace Replace Adjust	8-S17 8-S17 8-S17
<b>Oil Temperature Increases Rapidly</b>	<ul style="list-style-type: none"> <li>Relief valve operating               <ul style="list-style-type: none"> <li>- Relief valve malfunctioning</li> <li>- Hydraulic line is clogged</li> </ul> </li> <li>Hydraulic pump leak or damaged</li> <li>Oil leaks from valves</li> </ul>	Adjust or replace Clean or replace Repair or replace Repair or replace	8-S11 – 8-S7 to S10 –

W10143220

## 2. SERVICING SPECIFICATIONS

### HYDRAULIC PUMP

Item		Factory Specification	Allowable Limit
Hydraulic Pump <b>Condition</b> <ul style="list-style-type: none"> <li>Engine Speed : Approx. 2700 min<sup>-1</sup> (rpm)</li> <li>Rated pressure L3130, L3430, L3830 : 17.1 to 18.1 MPa 174.4 to 184.6 kgf/cm<sup>2</sup> 2480 to 2625 psi</li> <li>L4630, L5030 : 18.1 to 19.1 MPa 184.6 to 194.8 kgf/cm<sup>2</sup> 2625 to 2770 psi</li> <li>Oil Temperature : 40 to 60 °C 104 to 140 °F</li> </ul>	Delivery at No Pressure L3130, L3430, L3830	Above 31.5 L/min. 8.32 U.S.gals/min. 6.93 Imp.gals/min.	–
	L4630, L5030	Above 37.0 L/min. 9.78 U.S.gals/min. 8.14 Imp.gals/min.	–
	Delivery at Rated Pressure L3130, L3430, L3830	Above 30.9 L/min. 8.16 U.S.gals/min. 6.80 Imp.gals/min.	27.6 L/min. 7.29 U.S.gals/min. 6.07 Imp.gals/min.
	L4630, L5030	Above 36.3 L/min. 9.59 U.S.gals/min. 7.99 Imp.gals/min.	32.4 L/min. 8.56 U.S.gals/min. 7.13 Imp.gals/min.
Housing Bore	Depth of Scratch	–	0.09 mm 0.0035 in.
Bushing to Gear Shaft	Clearance	0.020 to 0.081 mm 0.0008 to 0.0032 in.	0.15 mm 0.0059 in.
Gear Shaft	O.D.	14.970 to 14.980 mm 0.5894 to 0.5898 in.	–
Bushing	I.D.	15.000 to 15.051 mm 0.5906 to 0.5926 in.	–
Side Plate	Thickness	2.48 to 2.50 mm 0.0976 to 0.0984 in.	2.40 mm 0.0945 in.

W10138740

### RELIEF VALVE

Relief Valve <b>Condition</b> <ul style="list-style-type: none"> <li>Engine Speed : Maximum</li> <li>Oil Temperature : 40 to 60 °C 104 to 140 °F</li> </ul>	Setting Pressure L3130, L3430, L3830	17.1 to 18.1 MPa 174.4 to 184.4 kgf/cm <sup>2</sup> 2480 to 2625 psi	–
	L4630, L5030	18.1 to 19.1 MPa 184.6 to 194.8 kgf/cm <sup>2</sup> 2625 to 2770 psi	–

W10138740

### REAR HYDRAULIC BLOCK AND VALVES

Lift Arm	Free Play (at Maximum Raising Position)	10 to 15 mm 0.39 to 0.59 in.	–
----------	---	---------------------------------	---

W10138740

**CYLINDER SAFETY VALVE**

Item		Factory Specification	Allowable Limit
Cylinder Safety Valve	Operating Pressure	19.6 to 22.6 MPa 200 to 230 kgf/cm <sup>2</sup> 2845 to 3271 psi	—

W10115520

**LIFT ARM SUPPORT AND HYDRAULIC CYLINDER**

Hydraulic Cylinder	I.D.	55.000 to 55.074 mm 2.16535 to 2.16827 in.	55.100 mm 2.16929 in.
--------------------	------	---	--------------------------

W10118710

### 3. TIGHTENING TORQUES

Tightening torques of screws, bolts and nuts on the table below are especially specified.  
(For general use screws, bolts and nuts : See page G-10.)

Item	N-m	kgf-m	ft-lbs
Main delivery pipe joint bolt	49.0 to 68.6	5.0 to 7.0	36.2 to 50.6
Power steering delivery pipe joint bolt (Except HST model)	49.0 to 68.6	5.0 to 7.0	36.2 to 50.6
GST/PTO delivery pipe joint bolt	34.3 to 39.2	3.5 to 4.0	25.3 to 28.9
Regulator delivery pipe joint bolt	39.2 to 49.0	4.0 to 5.0	28.9 to 36.2
Regulator valve mounting screw	17.7 to 20.6	1.8 to 2.1	13.0 to 15.2
Power steering delivery pipe joint bolt (HST model)	39.2 to 49.0	4.0 to 5.0	28.9 to 36.2
Hydraulic pump assembly mounting screw and nut	23.5 to 27.5	2.4 to 2.8	17.4 to 20.3
Pump cover mounting screw	39.2 to 44.1	4.0 to 4.5	28.9 to 32.5
Relief valve plug	49.0 to 68.6	5.0 to 7.0	36.2 to 50.6
Hydraulic cylinder hose	34.3 to 48.1	3.5 to 4.9	25.3 to 35.4
Delivery pipe joint bolt	49.0 to 68.6	5.0 to 7.0	36.2 to 50.6
Cylinder safety valve assembly	39.2 to 49.0	4.0 to 5.0	28.9 to 36.2
Cylinder safety valve lock nut	58.8 to 78.5	6.0 to 8.0	43.4 to 57.9
Unload plug	39.2 to 58.8	4.0 to 6.0	28.9 to 43.4
Plug 2	39.2 to 58.8	4.0 to 6.0	28.9 to 43.4
Plug 1	39.2 to 58.8	4.0 to 6.0	28.9 to 43.4
Lift arm pin mounting nut	77.5 to 90.2	7.9 to 9.2	57.1 to 66.5
Lift arm pin lock nut	62.8 to 72.6	6.4 to 7.4	46.3 to 53.5
Drawbar frame mounting screw (M14)	166.7 to 196.1	17.0 to 20.0	123.0 to 144.7
(M12)	77.5 to 90.2	7.9 to 9.2	57.1 to 66.5
Top link holder mounting screw	77.5 to 90.2	7.9 to 9.2	57.1 to 66.5

W1012736

## 4. CHECKING, DISASSEMBLING AND SERVICING

### [1] HYRAULIC PUMP

#### (1) Checking

##### (A) Pump Test Using Flow-meter

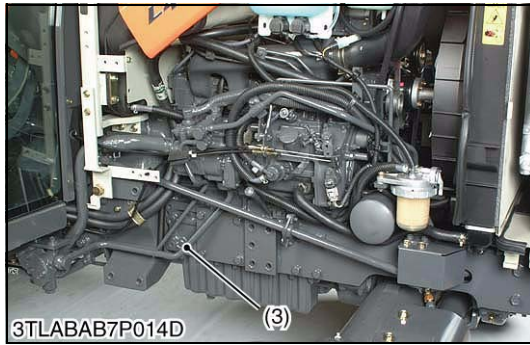

#### Preparation

1. Open the bonnet (1).
2. Remove the side skirt RH (2).
3. Remove the main delivery pipe (3).

#### **(When reassembling)**

- Install the copper washers firmly.

Tightening torque	Main delivery pipe joint bolt	49.0 to 68.6 N·m 5.0 to 7.0 kgf·m 36.2 to 50.6 ft-lbs
-------------------	-------------------------------	---

- (1) Bonnet  
(2) Side Skirt RH

- (3) Main Delivery Pipe

W1012121





### Hydraulic Flow Test

#### ■ IMPORTANT

- When using a flowmeter other than KUBOTA specified flowmeter, be sure to use the instructions with that flowmeter.
- Do not close the flowmeter loading valve completely, before testing, because it has no relief valve.

1. Install the pump adaptor (see page G-54) with O-ring to the pump discharge port.
2. Connect the hydraulic test hose to the adaptor and flowmeter inlet port.
3. Connect the other hydraulic test hose to the flowmeter outlet port and to transmission fluid filling plug hole.
4. Open the flowmeter loading valve completely. (Turn counterclockwise.)
5. Start the engine and set the engine speed at **2000 to 2200 min<sup>-1</sup> (rpm)**.
6. Slowly close the loading valve to generate pressure approx. **14.7 MPa (150 kgf/cm<sup>2</sup>, 2133 psi)**. Hold in this condition until oil temperature reached approx. **40 °C (104 °F)**
7. Open the loading valve completely.
8. Set the engine speed. (Refer to **Condition**.)
9. Read and note the pump delivery at no pressure.
10. Slowly close the loading valve to increase (Rated pressure). As the load is increased, engine speed drops, therefore, reset the engine speed.
11. Read and note the pump delivery at rated pressure.
12. Open the loading valve completely and stop the engine.
13. If the pump delivery does not reach the allowable limit, check the pump suction line, oil filter or hydraulic pump.

#### Condition

- Engine Speed.....Approx. 2700 min<sup>-1</sup> (rpm)
- Rated pressure
 

L3130, L3430, L3830 ....	17.1 to 18.1 MPa
	174.4 to 184.6 kgf/cm <sup>2</sup>
	2480 to 2625 psi
L4630, L5030 .....	18.1 to 19.1 MPa
	184.6 to 194.8 kgf/cm <sup>2</sup>
	2625 to 2770 psi
- Oil Temperature ..... 40 to 60 °C  
104 to 140 °F

**A : Manual and Glide Shift  
Transmission**

**B : Hydrostatic Transmission**

W10187910

**Hydraulic Flow Test (Continued)****[L3130, L3430, L3830]**

Hydraulic pump delivery at no pressure	Factory spec.	Above 31.5 L/min. 8.32 U.S.gals/min. 6.93 Imp.gals/min.
Hydraulic pump delivery at rated pressure	Factory spec.	Above 30.9 L/min. 8.16 U.S.gals/min. 6.80 Imp.gals/min.
	Allowable limit	27.6 L/min. 7.29 U.S.gals/min. 6.07 Imp.gals/min.

**[L4630, L5030]**

Hydraulic pump delivery at no pressure	Factory spec.	Above 37.0 L/min. 9.78 U.S.gals/min. 8.14 Imp.gals/min.
Hydraulic pump delivery at rated pressure	Factory spec.	Above 36.3 L/min. 9.59 U.S.gals/min. 7.99 Imp.gals/min.
	Allowable limit	32.4 L/min. 8.56 U.S.gals/min. 7.13 Imp.gals/min.

W1013113

**(2) Disassembling and Assembling****■ IMPORTANT**

- The hydraulic pump is precision machined and assembled : if disassemble once, it may be unable to maintain its original performance. Therefore, when the hydraulic pump fails, replacement should be carried out with the hydraulic pump assembled except when emergency repair is unavoidable.
- When repair is required, follow the disassembly and servicing procedures shown below with utmost care.
- Be sure to test the hydraulic pump with a flowmeter before disassembling.
- After reassembly, be sure to perform break-in operation and ensure that there is nothing abnormal with the hydraulic pump.

**(A) Removing Hydraulic Pump Assembly****Bonnet and Side Skirt RH**

1. Open the bonnet (1).
2. Remove the side skirt RH (2).

(1) Bonnet

(2) Side Skirt RH

W1014408

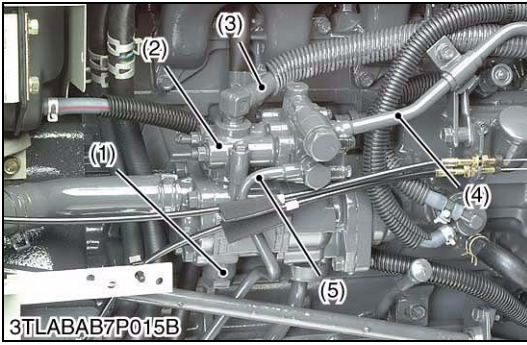

### Regulator Valve (Manual and Glide Shift Transmission Models)

1. Disconnect the power steering delivery pipe (4) and return hose (3).
2. Disconnect the GST/PTO delivery pipe (5) and regulator delivery pipe (1).
3. Remove the regulator valve (2).

#### (When reassembling)

- Apply grease to the O-ring and take care not to damage it.
- Install the copper washers firmly.

Tightening torque	Power steering delivery pipe joint bolt	49.0 to 68.6 N-m 5.0 to 7.0 kgf-m 36.2 to 50.6 ft-lbs
	GST/PTO delivery pipe joint bolt	34.3 to 39.2 N-m 3.5 to 4.0 kgf-m 25.3 to 28.9 ft-lbs
	Regulator delivery pipe joint bolt	39.2 to 49.0 N-m 4.0 to 5.0 kgf-m 28.9 to 36.2 ft-lbs
	Regulator valve mounting screw	17.7 to 20.6 N-m 1.8 to 2.1 kgf-m 13.0 to 15.2 ft-lbs

- (1) Regulator Delivery Pipe                      (4) Power Steering Delivery Pipe  
 (2) Regulator Valve                              (5) GST/PTO Delivery Pipe  
 (3) Return Hose

W1014496

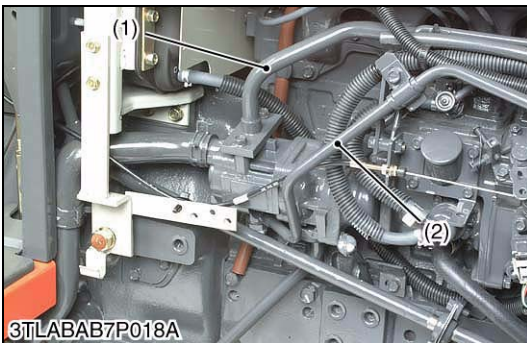

### Power Steering Delivery Pipe and Oil Cooler Return Pipe (HST Models)

1. Disconnect the power steering delivery pipe (2) and oil cooler return pipe (1).

#### (When reassembling)

- Install the copper washers firmly.
- Take care not to damage the O-ring.

Tightening torque	Power steering delivery pipe joint bolt	39.2 to 49.0 N-m 4.0 to 5.0 kgf-m 28.9 to 36.2 ft-lbs
-------------------	---	---

- (1) Oil Cooler Return Pipe                      (2) Power Steering Delivery Pipe

W1014726

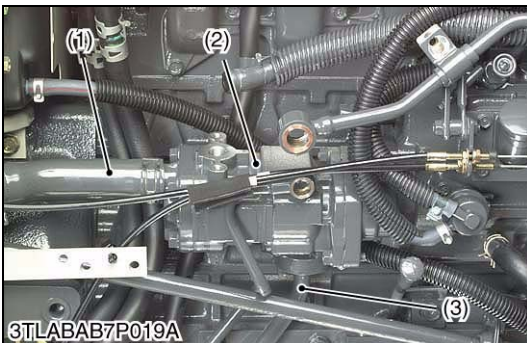

### Hydraulic Pump Assembly

1. Disconnect the suction hose (1) and main delivery pipe (3).
2. Remove the hydraulic pump assembly (2).

#### (When reassembling)

- Apply grease to the O-ring and take care not to damage it.

Tightening torque	Hydraulic pump assembly mounting screw and nut	23.5 to 27.5 N-m 2.4 to 2.8 kgf-m 17.4 to 20.3 ft-lbs
-------------------	--	---

- (1) Suction Hose                                      (3) Main Delivery Pipe  
 (2) Hydraulic Pump Assembly

W1014977

## (B) Disassembling Hydraulic Pump

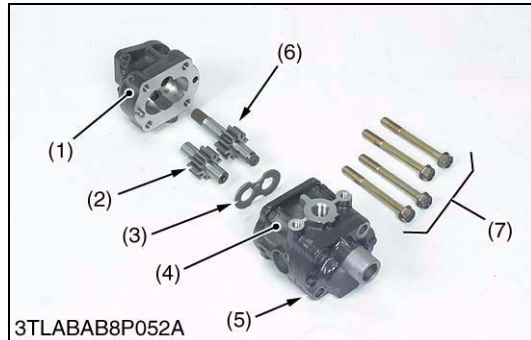

### Hydraulic Pump Assembly

1. Remove the pump cover mounting screws (7).
2. Remove the drive gear (6), driven gear (2) and side plate (3) from the casing.

### (When reassembling)

- Take care not to damage the gasket.
- Align the hole of the pump cover (5) and casing 2 (4).
- Install the side plate, noting its location and direction.
- Install the gears, noting its direction.

Tightening torque	Pump cover mounting screw	39.2 to 44.1 N·m 4.0 to 4.5 kgf·m 28.9 to 32.5 ft·lbs
-------------------	---------------------------	---

- |                 |                |
|-----------------|----------------|
| (1) Casing 1    | (5) Pump Cover |
| (2) Driven Gear | (6) Drive Gear |
| (3) Side Plate  | (7) Screw      |
| (4) Casing 2    |                |

W10135590

### Hydraulic Pump Running-In

After reassembly, perform break-in operation in the following manner, and check the pump for abnormality before use. If the pump temperature should rise noticeably during running-in, recheck should be performed.

1. Install the hydraulic pump to the tractor, and mount the suction pipe and delivery pipe securely.
2. Set the engine speed at 1300 to 1500  $\text{min}^{-1}$  (rpm), and operate the hydraulic pump at no load for about 10 minutes.
3. Set the engine speed at 2000 to 2200  $\text{min}^{-1}$  (rpm), and with the hydraulic pump applied with 2.94 MPa (30  $\text{kgf/cm}^2$ , 427 psi) to 4.90 MPa (50  $\text{kgf/cm}^2$ , 711 psi) pressure, operate it for approx. 15 minutes.
4. With the engine set to maximum speed, fully turn the steering wheel to the left or right, then actuate the relief valve five times for 25 seconds (one time 5 seconds).

W10145360

## (3) Servicing



### Housing Bore (Depth of Scratch)

1. Check for the scratch on the interior surface of the housing caused by the gear.
2. If the scratch reaches more than half the area of the interior surface of the housing, replace at pump assembly.
3. Measure the housing I.D. where the interior surface is not scratched, and measure the housing I.D. where the interior surface is scratched.
4. If the values obtained in the two determinations differ by more than the allowable limit, replace the hydraulic pump as a unit.

Depth of scratch	Allowable limit	0.09 mm 0.0035 in.
------------------	-----------------	-----------------------

### (Reference)

- Use a cylinder gauge to measure the housing I.D.

W10146490





### Clearance between Bushing and Gear Shaft

1. Measure the gear shaft O.D. with an outside micrometer.
2. Measure the bushing I.D. with an inside micrometer or cylinder gauge, and calculate the clearance.
3. If the clearance exceeds the allowable limit, replace the gear shaft and the bushings as a unit.

Clearance between bushing and gear shaft	Factory spec.	0.020 to 0.081 mm 0.0008 to 0.0032 in.
	Allowable limit	0.15 mm 0.0059 in.

Gear shaft O.D.	Factory spec.	14.970 to 14.980 mm 0.5894 to 0.5898 in.
Bushing I.D.	Factory spec.	15.000 to 15.051 mm 0.5906 to 0.5926 in.

W1015746



### Side Plate Thickness

1. Measure the side plate thickness with an outside micrometer.
2. If the thickness is less than the allowable limit, replace it.

Side plate thickness	Factory spec.	2.48 to 2.50 mm 0.0976 to 0.0984 in.
	Allowable limit	2.40 mm 0.0945 in.

W10134960

## [2] RELIEF VALVE

### (1) Checking and Adjusting

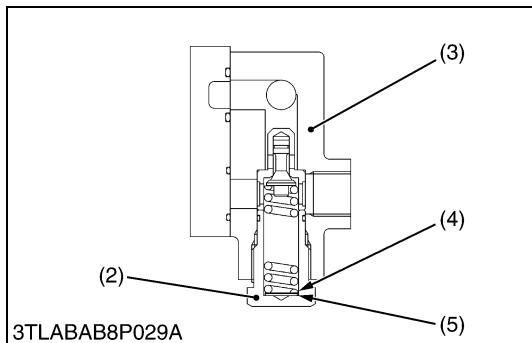
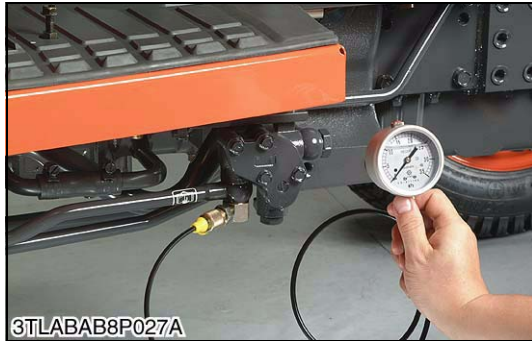

#### Relief Valve Setting Pressure Test

1. Remove the delivery pipe joint bolt from front hydraulic block.
2. Install the adaptor E. Then connect the cable and pressure gauge to adaptor E.
3. Start the engine and set at maximum speed.
4. Move the position control lever (1) all way up to operate the relief valve and read the gauge.
5. If the pressure is not within the factory specifications, remove the relief plug (2) of front hydraulic block (3) and adjust with the adjusting shims (4).
6. After the relief valve setting pressure test, reset the position control lever stopper firmly.

Relief valve setting pressure	Factory spec.	L3130	17.1 to 18.1 MPa
		L3430	174.4 to 184.6 kgf/cm <sup>2</sup>
		L3830	2480 to 2625 psi
		L4630	18.1 to 19.1 MPa
		L5030	184.6 to 194.8 kgf/cm <sup>2</sup>
			2625 to 2770 psi

#### Condition

- Engine speed.....Maximum
- Oil temperature.....40 to 60 °C  
104 to 140 °F

#### (Reference)

- Thickness of shims (4) : 0.1 mm (0.0039 in.)  
0.2 mm (0.0079 in.)  
0.4 mm (0.0157 in.)
- Pressure change per  
0.1 mm (0.0039 in.) shim : Approx. 264.8 kPa  
2.7 kgf/cm<sup>2</sup>  
38.4 psi

- |                            |                    |
|----------------------------|--------------------|
| (1) Position Control Lever | (4) Adjusting Shim |
| (2) Relief Plug            | (5) Washer         |
| (3) Front Hydraulic Block  |                    |

W1014806

### (2) Disassembling and Assembling

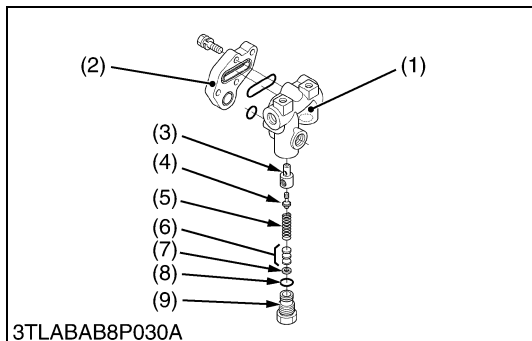

#### Relief Valve

1. Remove the plug (9), and draw out the spring (5) and the poppet (4).
2. Take out the valve seat (3).

#### (When reassembling)

- Take care not to damage the O-ring.

Tightening torque	Relief valve plug	49.0 to 68.6 N-m 5.0 to 7.0 kgf-m 36.2 to 50.6 ft-lbs
-------------------	-------------------	---

#### ■ IMPORTANT

- After disassembling and assembling the relief valve, be sure to adjust the relief valve setting pressure.

- |                           |                    |
|---------------------------|--------------------|
| (1) Front Hydraulic Block | (6) Adjusting Shim |
| (2) Cap                   | (7) Washer         |
| (3) Valve Seat            | (8) O-ring         |
| (4) Poppet                | (9) Plug           |
| (5) Spring                |                    |

W1015237



## [3] REAR HYDRAULIC BLOCK AND VALVES

### (1) Checking and Adjusting

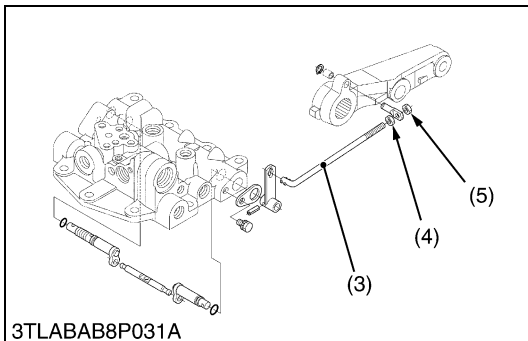

#### Position Control Feedback Rod Adjustment

1. Set the position control lever (1) to the lowest position.
2. Start the engine, and after warming-up, set the engine speed at the idling.
3. Move the position control lever (1) to the uppermost position. [The lever is raised until spring finishes shrinking, and the lever position is put into the state to release.]
4. While pulling the feedback rod to the rear, turn the adjusting nut (4) clockwise until the relief valve begins to be operated.
5. From the relief valve operating position, turn back the adjusting nut (4) counterclockwise by 2 turns.
6. Tighten the lock nut (5).
7. Set the engine speed at the maximum.
8. Move the position control lever (1) to the lowest position and uppermost position to check the relief valve does not operate.
9. Set the position control lever (1) to the uppermost position, then move the lift arm to the upper end by hand and measure the free play.
10. If the measurement is not within the factory specifications, adjust the position control feedback rod setting length.
  - To reduce lift arm free play → Shorten the position control feedback rod setting length.
  - To increase lift arm free play → Lengthen the position control feedback rod setting length.

Lift arm free play at maximum raising position	Factory spec.	10 to 15 mm 0.39 to 0.59 in.

- (1) Position Control Lever                      (4) Adjusting Nut  
 (2) Stopper    (5) Lock Nut  
 (3) Position Control Feedback Rod

W1015610

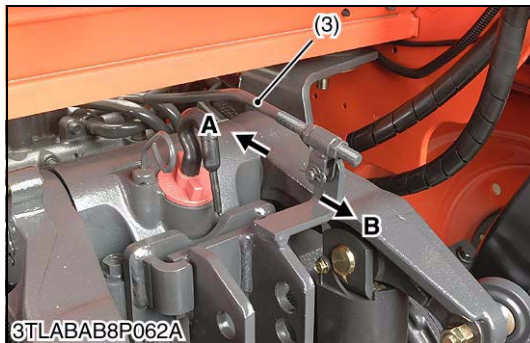
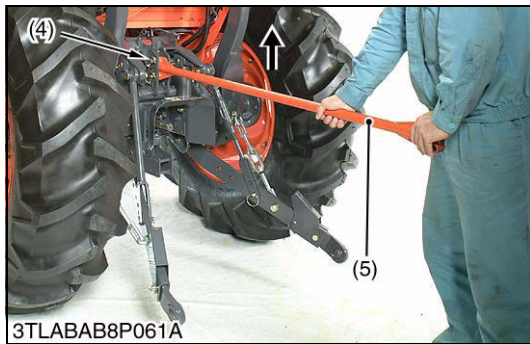
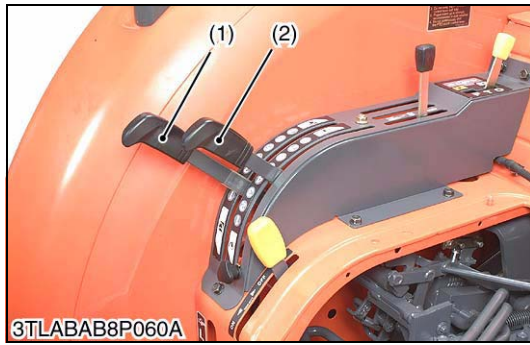

### **Draft Control Feedback Rod Adjustment (If equipped)**

1. Attach the test bar (5) to the top link bracket (3).
2. Start the engine and set the speed at maximum.
3. Set the position control lever (2) between 4 and 5.
4. Set the draft control lever (1) between lever guide 1 and 2.
5. Lift the test bar (5) upward until the top link bracket (4) comes in contact with the stopper.
6. Confirm that the lower link begin to rise.
7. If the specified play is not obtained, adjust the feedback rod (3) to **A** or **B** position.

- (1) Draft Control Lever
- (2) Position Control Lever
- (3) Feedback Rod
- (4) Top Link Bracket
- (5) Test Bar

**A : Insensitive**  
**B : Sensitive**

W1017519

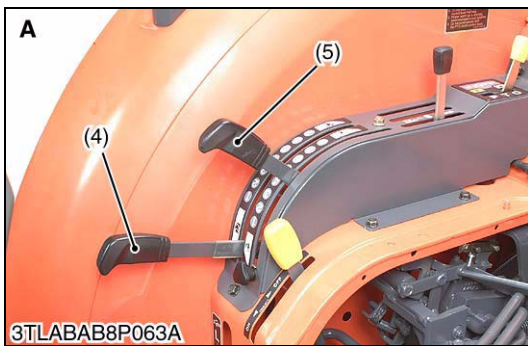
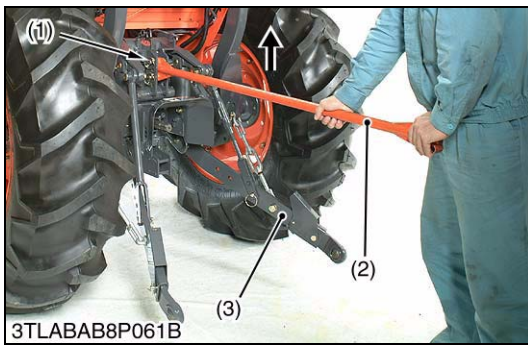

### Checking Draft Control Sensitivity (If equipped)

1. Attach the test bar (2) to the top link bracket.
2. Start the engine, set at maximum speed.
3. Set the draft control lever (5) to the lowest position. (Refer to figure A.)
4. Set the position control lever (4) between lever guide 4 and 5. (Refer to figure A.)
5. Lift the test bar (2) upward until the top link bracket (1) comes in contact with the stopper.
6. Confirm the lower link does not rise.
7. Set the draft control lever (4) to 7 position of the lever guide. (Refer to figure B.)
8. Lift the test bar (2).
9. Confirm the lower links (3) must rise before the top link bracket (1) contact the stopper.
10. If the specified play is not obtained, readjust the feedback rod. (Refer "Adjusting Draft Control Position Section".)

- |                      |                            |
|----------------------|----------------------------|
| (1) Top Link Bracket | (4) Draft Control Lever    |
| (2) Test Bar         | (5) Position Control Lever |
| (3) Lower Link       |                            |

W1018582

## (2) Disassembling and Assembling

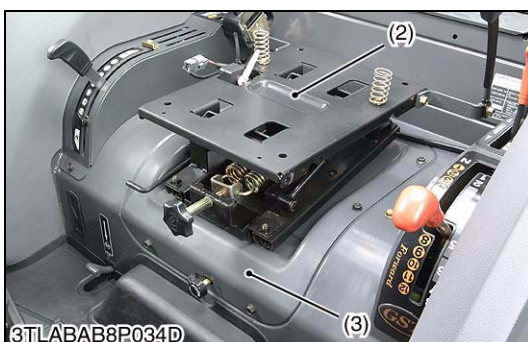

### Seat, Seat Bracket and Cover

1. Remove the seat (1).
  2. Remove the seat bracket (2) together with cover (3).
- |                  |           |
|------------------|-----------|
| (1) Seat         | (3) Cover |
| (2) Seat Bracket |           |

W1015907



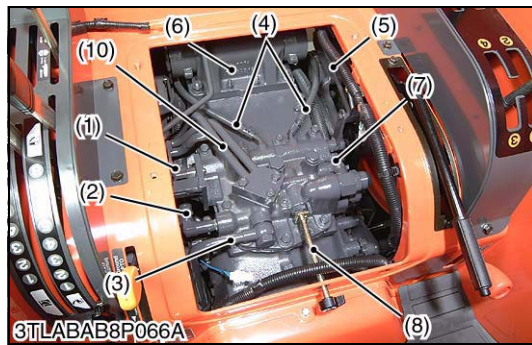

### Rear Hydraulic Block

1. Disconnect the position control feedback rod (5) and return hoses (4).
2. Remove the lowering speed adjusting valve joint shaft (8).
3. Disconnect the hydraulic cylinder hose RH (2) and delivery pipe (3).
4. Tap out the spring pin from position control lever (1).
5. Remove the auxiliary control valve (9) and pipes (10).
6. Remove the rear hydraulic block mounting screws.
7. Remove the rear hydraulic block (6) and disconnect the position control lever (1) and hydraulic cylinder hose LH (7).

### (When reassembling)

- Install the copper washers firmly.
- Visually inspect the gasket, if damaged replace with new one.
- After reassembling, be sure to adjust the position control feedback rod length. (See page 8-S12.)

Tightening torque	Hydraulic cylinder hose	34.3 to 48.1 N·m 3.5 to 4.9 kgf·m 25.3 to 35.4 ft·lbs
	Delivery pipe joint bolt	49.0 to 68.6 N·m 5.0 to 7.0 kgf·m 36.2 to 50.6 ft·lbs

- |                                   |  |
|-----------------------------------|--|
| (1) Position Control Lever        | (7) Hydraulic Cylinder Hose LH                 |
| (2) Hydraulic Cylinder Hose RH    | (8) Lowering Speed Adjusting Valve Joint Shaft |
| (3) Delivery Pipe                 | (9) Auxiliary Control Valve                    |
| (4) Return Hose                   | (10) Auxiliary Pipe                            |
| (5) Position Control Feedback Rod |  |
| (6) Rear Hydraulic Block          |  |

W1016371

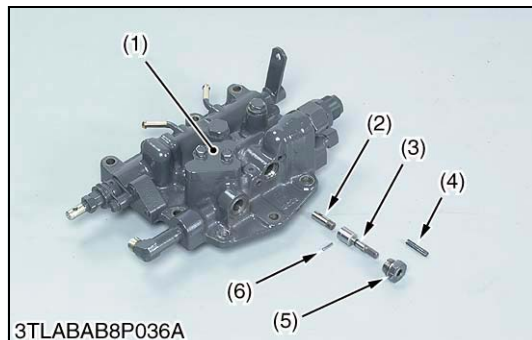

### Lowering Speed Adjusting Valve

1. Draw out the spring pin (4).
2. Remove the holder (5).
3. Draw out the lowering speed adjusting shaft (3), dowel pin (6) and rotor (2).

### (When reassembling)

- Take care not to damage the O-rings.

- |                                    |                |
|------------------------------------|----------------|
| (1) Rear Hydraulic Block           | (4) Spring Pin |
| (2) Rotor                          | (5) Holder     |
| (3) Lowering Speed Adjusting Shaft | (6) Dowel Pin  |

W1016653

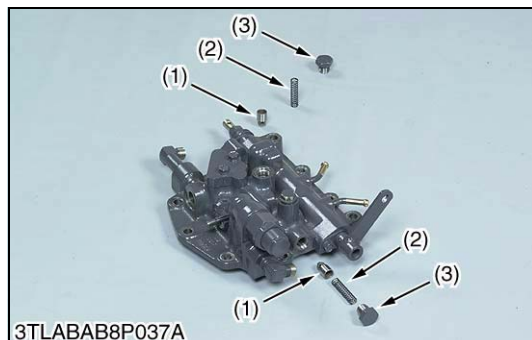

### Check Valves

1. Remove the plug (3).
2. Draw out the spring (2) and poppet (1).

### (When reassembling)

- Take care not to damage the O-ring.

- |            |          |
|------------|----------|
| (1) Poppet | (3) Plug |
| (2) Spring |          |

W1016889

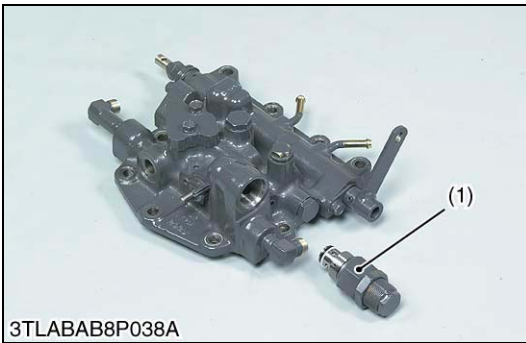

### Cylinder Safety Valve

1. Remove the cylinder safety valve assembly (1).
2. Secure the cylinder safety valve assembly in a vise.
3. Loosen the lock nut (3), and remove the adjust screw (2).
4. Draw out the spring (4), seat (5), and ball (6).

#### (When reassembling)

- Take care not to damage the O-rings.

Tightening torque	Cylinder safety valve assembly	39.2 to 49.0 N·m 4.0 to 5.0 kgf·m 28.9 to 36.2 ft-lbs
	Cylinder safety valve lock nut	58.8 to 78.5 N·m 6.0 to 8.0 kgf·m 43.4 to 57.9 ft-lbs

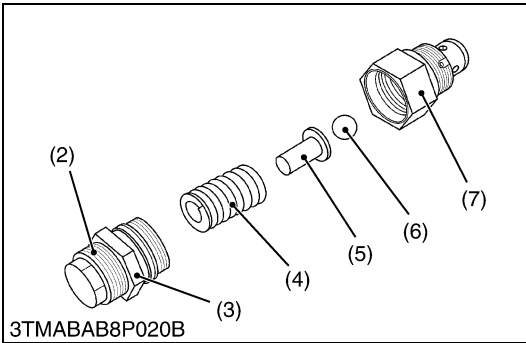

#### ■ IMPORTANT

- After disassembling and assembling the cylinder safety valve assembly, be sure to check the operating pressure.

- |                                    |             |
|------------------------------------|-------------|
| (1) Cylinder Safety Valve Assembly | (5) Seat    |
| (2) Adjusting Screw                | (6) Ball    |
| (3) Lock Nut                       | (7) Housing |
| (4) Spring                         |             |

W1017017

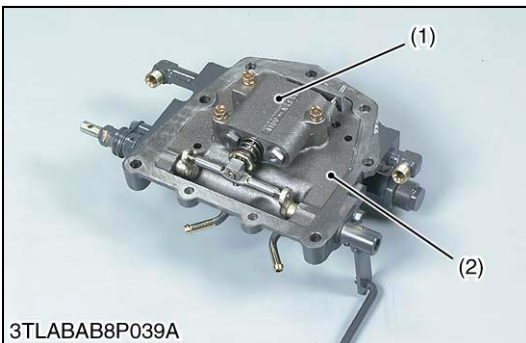

### Position Control Valve

1. Remove the position control valve (1) from rear hydraulic block (2).

#### (When reassembling)

- Take care not to damage the O-rings.

- |                            |                          |
|----------------------------|--------------------------|
| (1) Position Control Valve | (2) Rear Hydraulic Block |
|----------------------------|--------------------------|

W1017276

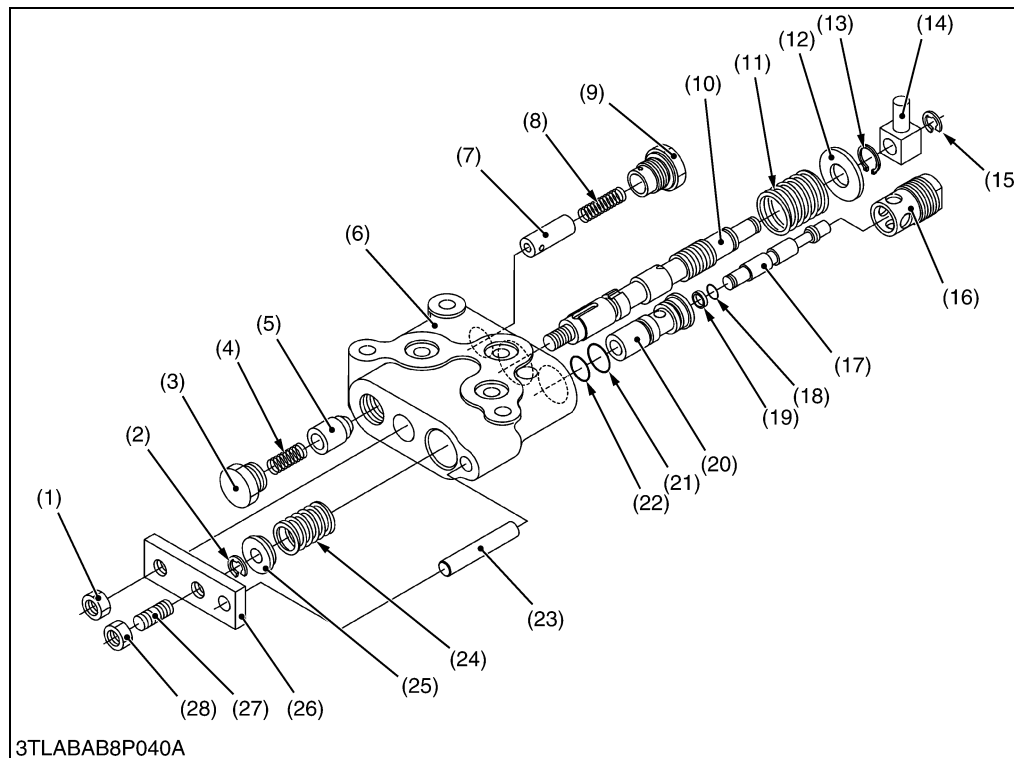
**Disassembling Position Control Valve**

- (1) Nut
- (2) External Snap Ring
- (3) Unload Plug
- (4) Spring
- (5) Unload Poppet
- (6) Valve Body
- (7) Unload Poppet 2
- (8) Spring
- (9) Plug 2
- (10) Spool
- (11) Spring
- (12) Plain Washer
- (13) External Snap Ring
- (14) Spool Joint
- (15) External Snap Ring
- (16) Plug 1
- (17) Poppet 2
- (18) O-ring
- (19) Backup Ring
- (20) Sleeve
- (21) O-ring
- (22) O-ring
- (23) Dowel Pin
- (24) Spring
- (25) Spring Seat
- (26) Connecting Plate
- (27) Adjusting Screw
- (28) Nut

W1017417

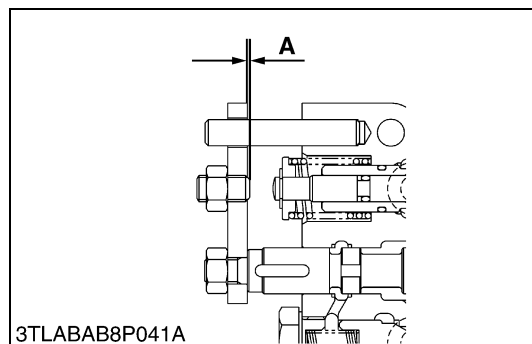

1. Remove the nut (1), and draw out the spool (10).
2. Remove the unload plug (3), and draw out the spring (4), unload poppet (5).
3. Remove the plug 2 (9), and draw out the spring (8), unload poppet 2 (7).
4. Remove the external snap ring (2), spring seat (25) and spring (24).
5. Remove the plug 1 (16), and draw out the poppet 2 (17), sleeve (20).

**NOTE**

- **Do not loosen the adjusting screw (27) unless necessary. If disassembled due to unavoidable reasons, be sure to set the dimension (A) to 0.2 mm (0.0079 in.).**

**(When reassembling)**

- Take care not to damage the backup ring and O-rings.

Tightening torque	Unload plug	39.2 to 58.8 N·m 4.0 to 6.0 kgf·m 28.9 to 43.4 ft-lbs
	Plug 2	39.2 to 58.8 N·m 4.0 to 6.0 kgf·m 28.9 to 43.4 ft-lbs
	Plug 1	39.2 to 58.8 N·m 4.0 to 6.0 kgf·m 28.9 to 43.4 ft-lbs

W1017707



### (3) Servicing

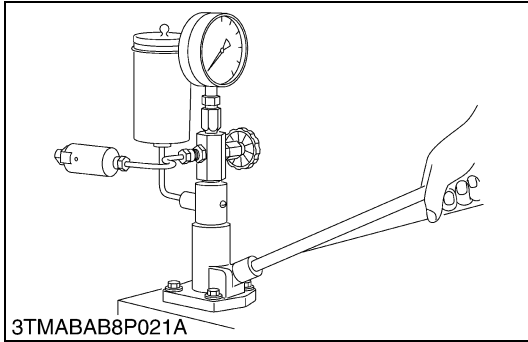

#### Operating Pressure of Cylinder Safety Valve

1. Attach the cylinder safety valve to a injection nozzle tester with a safety valve setting adaptor.
2. Measure the operating pressure of the cylinder safety valve.
3. If the operating pressure is not within the factory specifications, adjust by turning the adjusting screw (1).
4. After adjustment, tighten the lock nut (2) firmly.

**NOTE**

- Use specified transmission fluid (see page G-7, 8) to test the operating pressure of the cylinder safety valve.

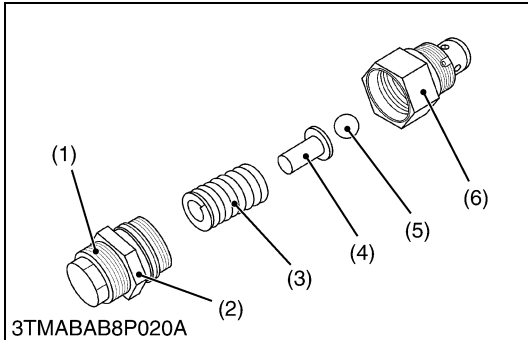

Cylinder safety valve operating pressure	Factory spec.	19.6 to 22.6 MPa 200 to 230 kgf/cm <sup>2</sup> 2845 to 3271 psi
--	---------------	--

Tightening torque	Cylinder safety valve lock nut	58.8 to 78.5 N-m 6.0 to 8.0 kgf-m 43.4 to 57.9 ft-lbs
-------------------	--------------------------------	---

- |                     |             |
|---------------------|-------------|
| (1) Adjusting Screw | (4) Seat    |
| (2) Lock Nut        | (5) Ball    |
| (3) Spring          | (6) Housing |

W10205610

## [4] LIFT ARM SUPPORT AND HYDRAULIC CYLINDER

### (1) Disassembling and Assembling



#### Top Link, Lift Rod and PTO Cover

1. Remove the top link (1) and PTO cover (3).
2. Disconnect the lift rods (2), (4) from lift arm.

**(When reassembling)**

Tightening torque	Lift arm pin mounting nut	77.5 to 90.2 N-m 7.9 to 9.2 kgf-m 57.1 to 66.5 ft-lbs
	Lift arm pin lock nut	62.8 to 72.6 N-m 6.4 to 7.4 kgf-m 46.3 to 53.5 ft-lbs

- |                 |                 |
|-----------------|-----------------|
| (1) Top Link    | (3) PTO Cover   |
| (2) Lift Rod RH | (4) Lift Rod LH |

W1018168

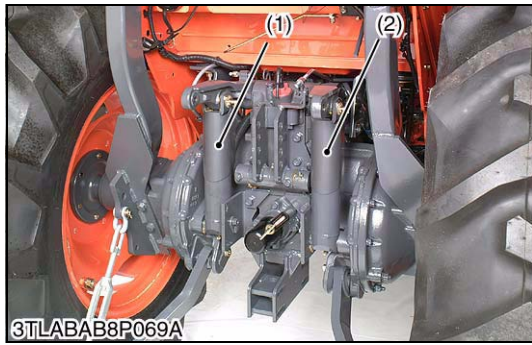

**Drawbar Frame and Hydraulic Cylinder**

1. Remove the drawbar frame (3).
2. Remove the hydraulic cylinder pins.
3. Disconnect the hydraulic cylinder hoses and return hoses, then remove the hydraulic cylinders (1), (2).

**(When reassembling)**

- Apply grease to the hydraulic cylinder pins.
- Install the cylinder pin (lower) from right hand side.

Tightening torque	Drawbar frame mounting screw (M14)	166.7 to 196.1 N·m 17.0 to 20.0 kgf·m 123.0 to 144.7 ft-lbs
	Drawbar frame mounting screw (M12)	77.5 to 90.2 N·m 7.9 to 9.2 kgf·m 57.1 to 66.5 ft-lbs
	Hydraulic cylinder hose	34.3 to 48.1 N·m 3.5 to 4.9 kgf·m 25.3 to 35.4 ft-lbs

- (1) Hydraulic Cylinder LH (2) Hydraulic Cylinder RH (3) Drawbar Frame

W1018343

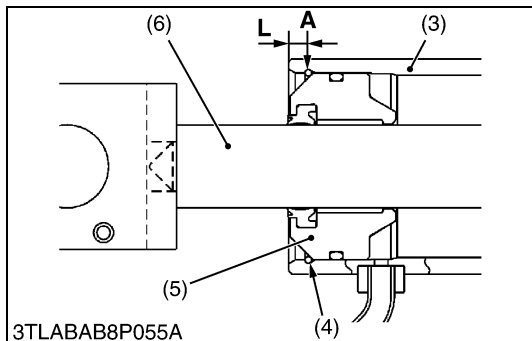
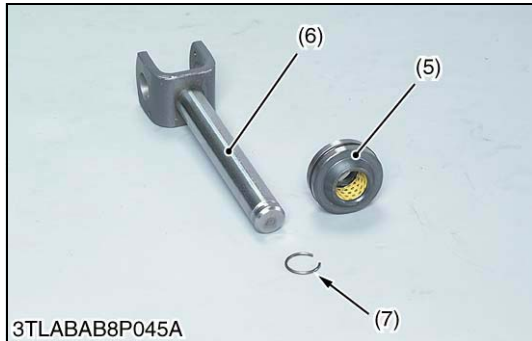
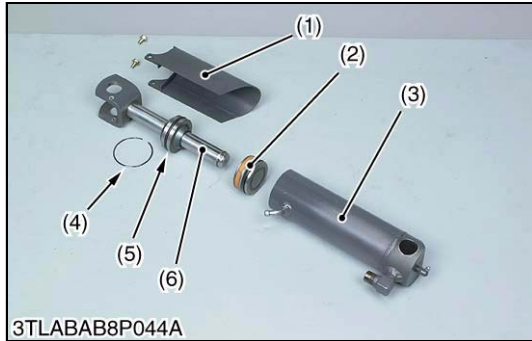

**Disassembling Hydraulic Cylinder**

1. Remove the cylinder cover (1).
2. Remove the liquid gasket from top of head (5).
3. Slightly tap-in the head (5) to inside, and remove the internal snap ring (4) by using the small screwdriver.
4. If the internal snap ring (4) cannot be removed by above-mentioned method, remove it by the following procedure.
  - Carefully clamp the cylinder tube (3) in a vise.
  - Drill approx. 2.5 mm (0.1 in.) diameter hole on the cylinder tube (position A) just over the internal snap ring (4) as shown in figure.
  - Use a small screwdriver and remove the internal snap ring (4). Simultaneously support this action by pushing from the outside of the cylinder tube with another small screwdriver or similar tool.
5. Draw out the rod (6) and head (5).
6. Inject the compressed air through the oil inlet port of the cylinder tube (3), and remove the piston (2).
7. Remove the external snap ring (7), and remove the head (5).

**(When reassembling)**

- Apply transmission fluid to the piston (2), head (5) and cylinder tube (3).
- Take care not to damage the O-ring, backup ring and seal.
- Apply liquid gasket (Three Bond 1208D or equivalent) to the top of head (5), while pressing the head (5) against internal snap ring (4).
- After reassembling the cylinder, be sure to close the drilled hole by liquid gasket.

- (1) Cylinder Cover (2) Piston (3) Cylinder Tube (4) Internal Snap Ring (5) Head (6) Rod (7) External Snap Ring
- A : Position for drilling**  
**L : 6.0 mm (0.236 in.)**

W1018811

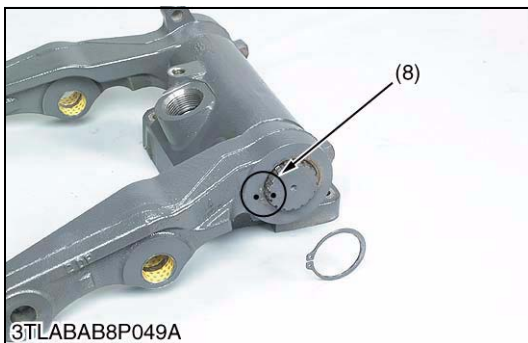
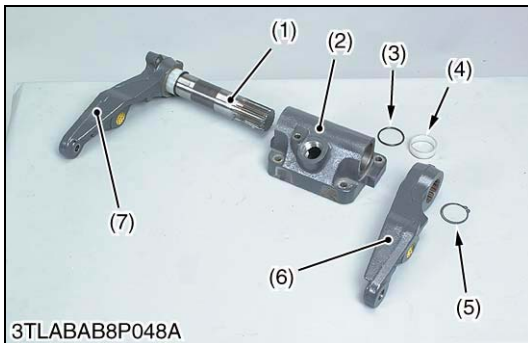
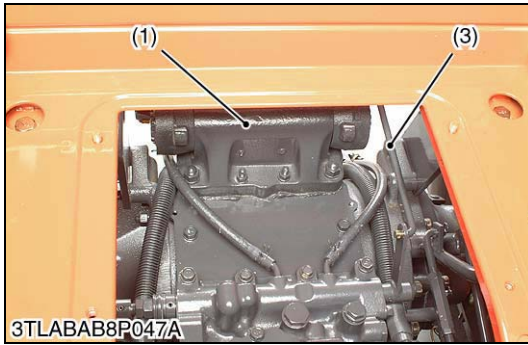
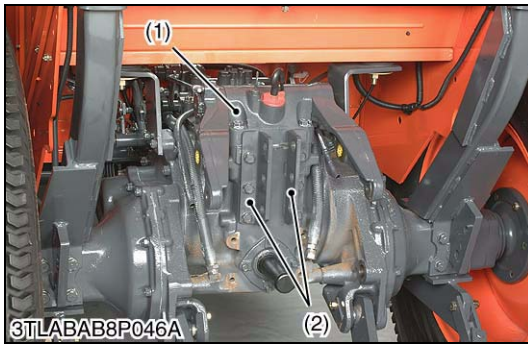

### Top Link Holder and Lift Arm Support

1. Disconnect the position control feedback rod (3).
2. Remove the top link holder (2).
3. Remove the lift arm support (1).

#### (When reassembling)

- Apply liquid gasket (Three Bond 1208D or equivalent) to joint face of the lift arm support and transmission case after eliminate the water, oil and stuck liquid gasket.
- After reassembling, be sure to adjust the position control feedback rod length. (See page 8-S12.)

Tightening torque	Top link holder mounting screw	77.5 to 90.2 N·m 7.9 to 9.2 kgf·m 57.1 to 66.5 ft·lbs
-------------------	--------------------------------	---

- (1) Lift Arm Support  
(2) Top Link Holder

- (3) Position Control Feedback Rod

W1019071

### Lift Arm and Lift Arm Shaft

1. Remove the external snap ring (5).
2. Remove the lift arm RH (6).
3. Draw out the lift arm shaft (1) and lift arm LH (7) as a unit.
4. Remove the collar (4) and O-ring (3).

#### (When reassembling)

- Align the alignment marks (8) of the lift arm shaft and lift arms.
- Apply grease to the right and left bushings of lift arm support and O-rings.
- Take care not to damage the O-rings.

- (1) Lift Arm Shaft  
(2) Lift Arm Support  
(3) O-ring  
(4) Collar

- (5) External Snap Ring  
(6) Lift Arm RH  
(7) Lift Arm LH  
(8) Alignment Mark

W1019375

**(2) Servicing**



3TLABAB8P045B

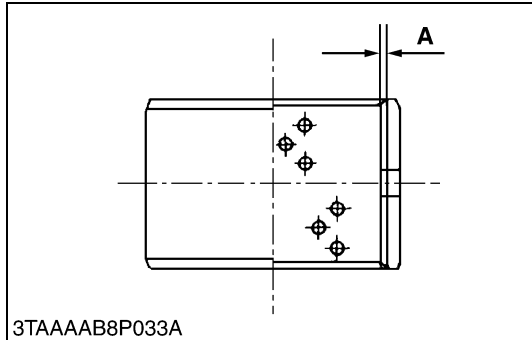

3TAAAAB8P033A



3TLABAB8P050A



3TLABAB8P051A

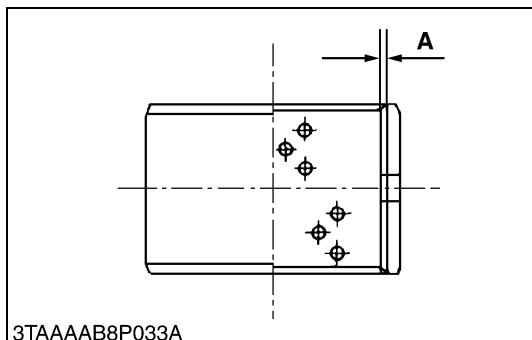

3TAAAAB8P033A

**Hydraulic Cylinder Rod Bushing**

1. Visually inspect the DX bushings for signs of wear or damage. (The DX bushing tends to show concentrated wear.)
2. If the DX bushing is worn beyond the alloy portion (**A**), replace it.

**(Reference)**

Hydraulic cylinder rod bushing	Alloy thickness ( <b>A</b> )	0.57 mm 0.0224 in.
--------------------------------	------------------------------	-----------------------

W1019611

**Hydraulic Cylinder I.D.**

1. Measure the hydraulic cylinder I.D. with a cylinder gauge.
2. If the cylinder I.D. exceed the allowable limit, replace the cylinder tube.

Hydraulic cylinder I.D.	Factory spec.	55.000 to 55.074 mm 2.16535 to 2.16827 in.
	Allowable limit	55.100 mm 2.16929 in.

W1019902

**Lift Arm Support Bushing**

1. Visually inspect the DX bushings for signs of wear or damage. (The DX bushing tends to show concentrated wear.)
2. If the DX bushing is worn beyond the alloy portion (**A**), replace it.

**(Reference)**

Lift arm support bushing	Alloy thickness ( <b>A</b> )	0.57 mm 0.0224 in.
--------------------------	------------------------------	-----------------------

W1020043



### Lift Arm Bushing

1. Visually inspect the DX bushings for signs of wear or damage.  
(The DX bushing tends to show concentrated wear.)
2. If the DX bushing is worn beyond the alloy portion (**A**), replace it.

#### (Reference)

Lift arm bushing	Alloy thickness ( <b>A</b> )	0.57 mm 0.0224 in.
------------------	------------------------------	-----------------------

W1020165

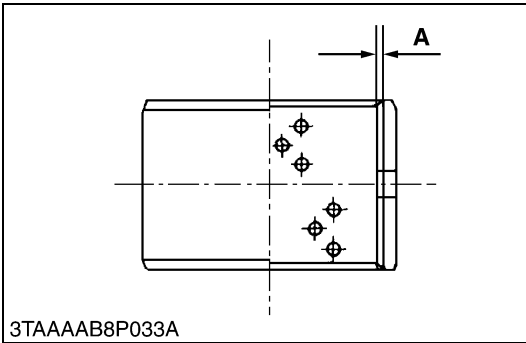

# **9 ELECTRICAL SYSTEM**



# MECHANISM

## CONTENTS

1. WIRING DIAGRAM .....	9-M1
[1] MANUAL TRANSMISSION MODEL .....	9-M1
(1) ROPS Type .....	9-M1
(2) Cabin Type .....	9-M2
[2] GST MODEL .....	9-M3
[3] HST MODEL .....	9-M4
[4] CABIN TYPE .....	9-M5
[5] COLOR OF WIRING .....	9-M6
2. ELECTRONIC CONTROL PANEL .....	9-M7
[1] SYSTEM OUTLINE AND ELECTRICAL CIRCUIT .....	9-M7
(1) System Outline .....	9-M7
(2) Control Items .....	9-M8
[2] CONSTRUCTION AND FUNCTION OF COMPONENTS .....	9-M9
[3] CONTROL SYSTEM .....	9-M18
(1) Basic Control System .....	9-M18
(2) Assistant Control System .....	9-M25
3. STARTING SYSTEM .....	9-M28
[1] MANUAL ROPS MODEL .....	9-M28
[2] MANUAL CABIN MODEL .....	9-M1
[3] GST MODEL .....	9-M1
[4] HST MODEL .....	9-M31
4. CHARGING SYSTEM .....	9-M32
5. LIGHTING SYSTEM .....	9-M33
[1] ROPS TYPE .....	9-M33
[2] CABIN TYPE .....	9-M34

# 1. WIRING DIAGRAM

## [1] MANUAL TRANSMISSION MODEL

### (1) ROPS Type

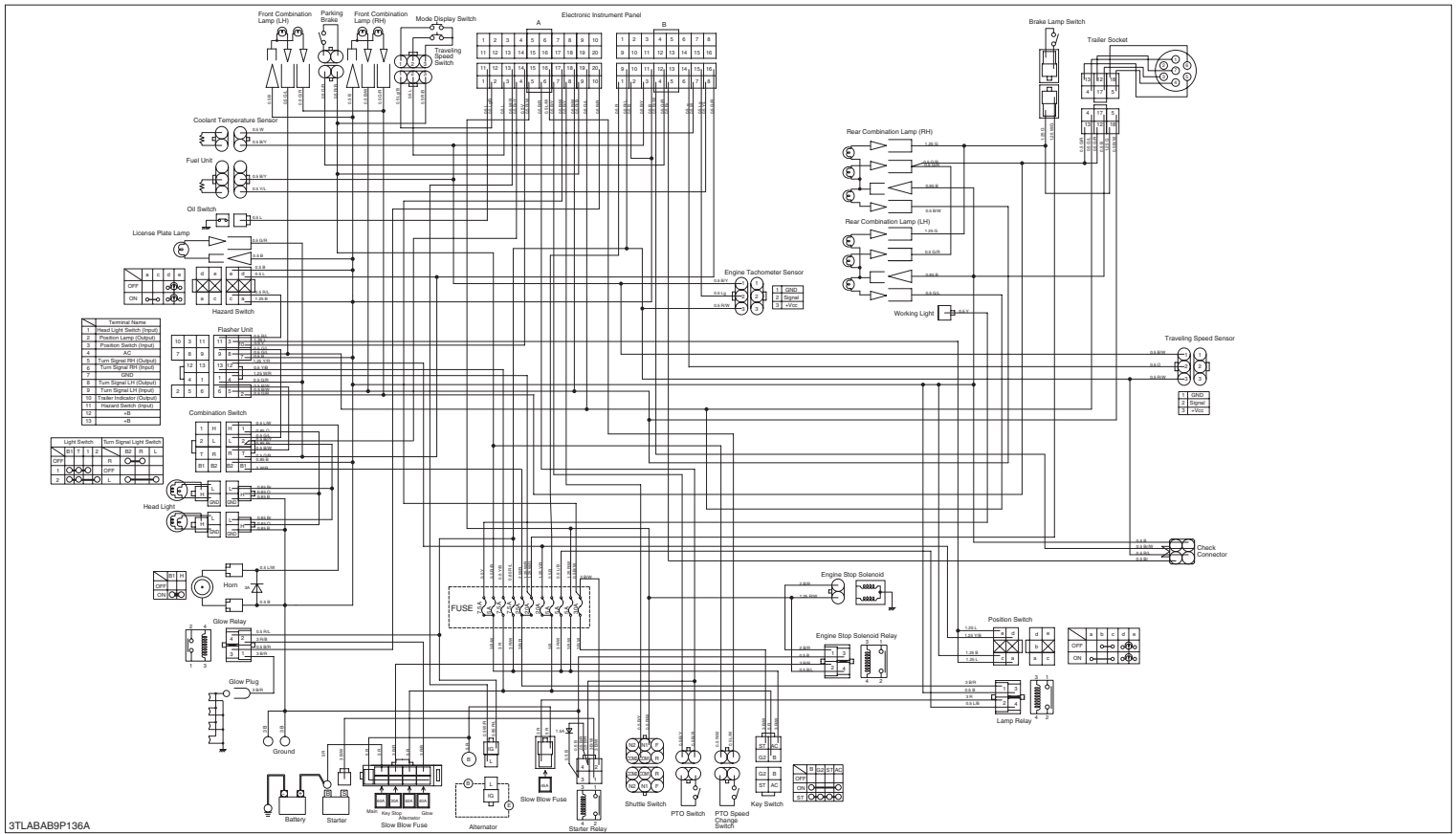

(2) Cabin Type

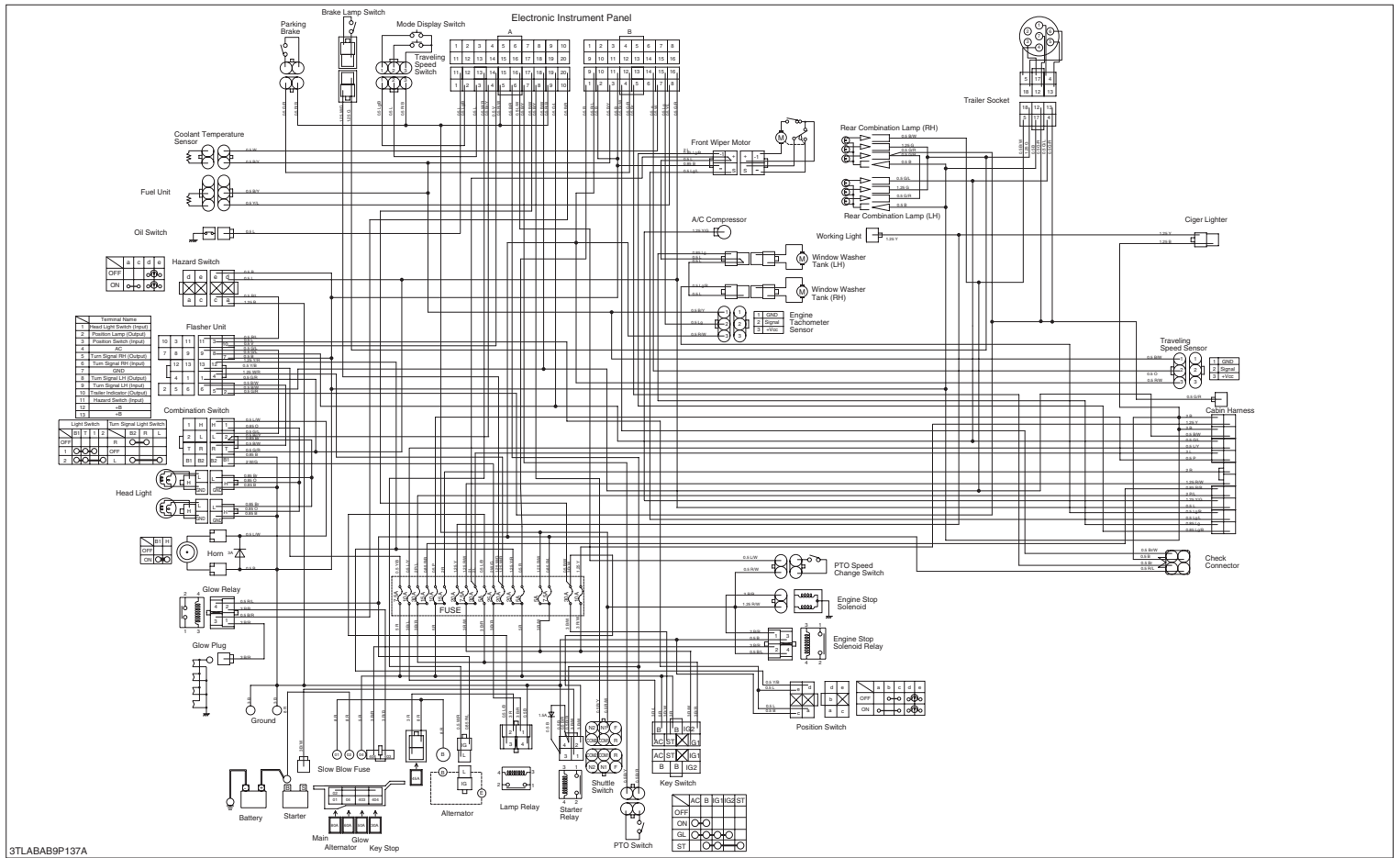

3TLABAB9P137A

9-M2

KISC issued 02, 2007 A

[2] GST MODEL

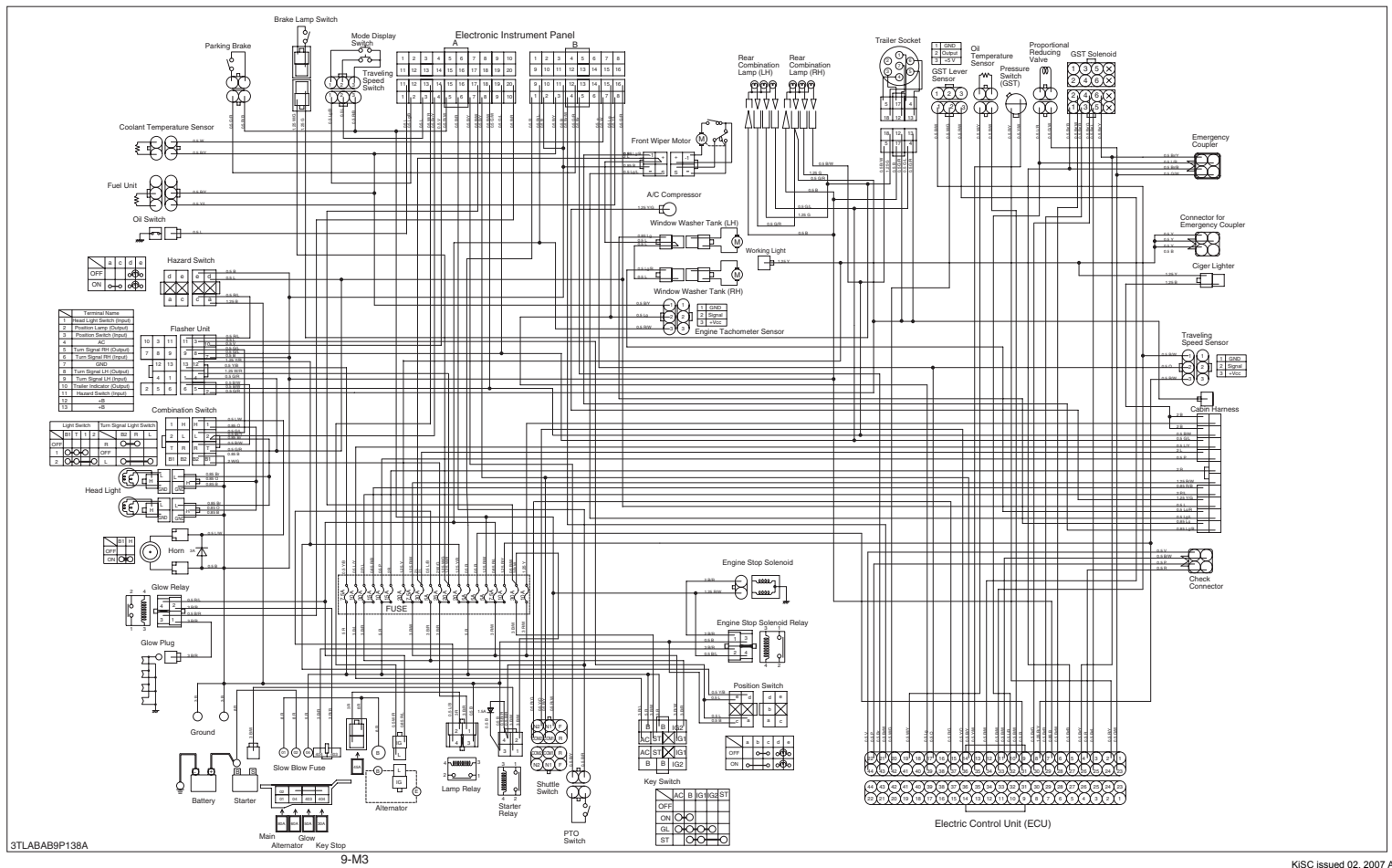

[3] HST MODEL

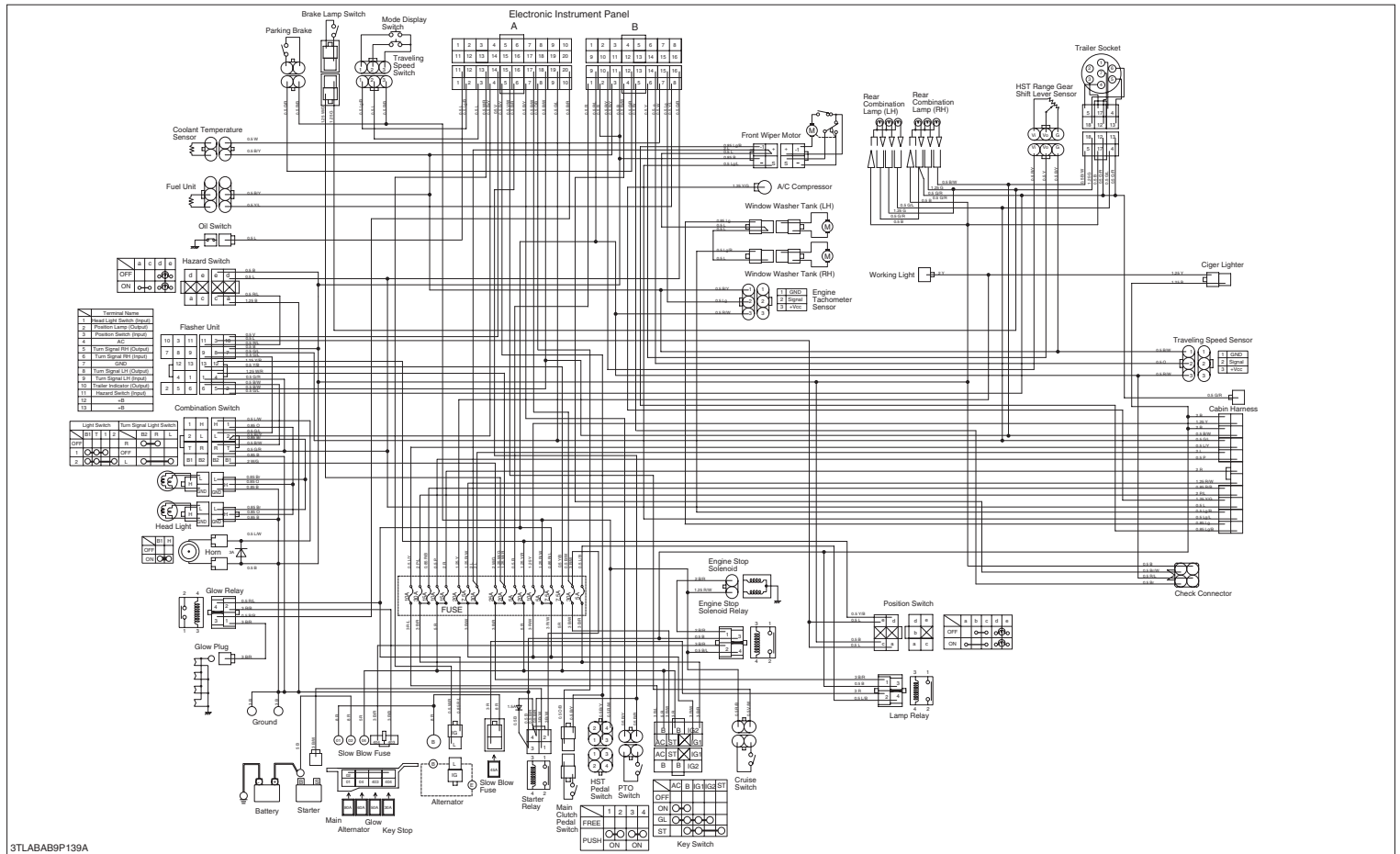

3TLAB89P139A

9-M4

KISC issued 02, 2007 A

[4] CABIN TYPE

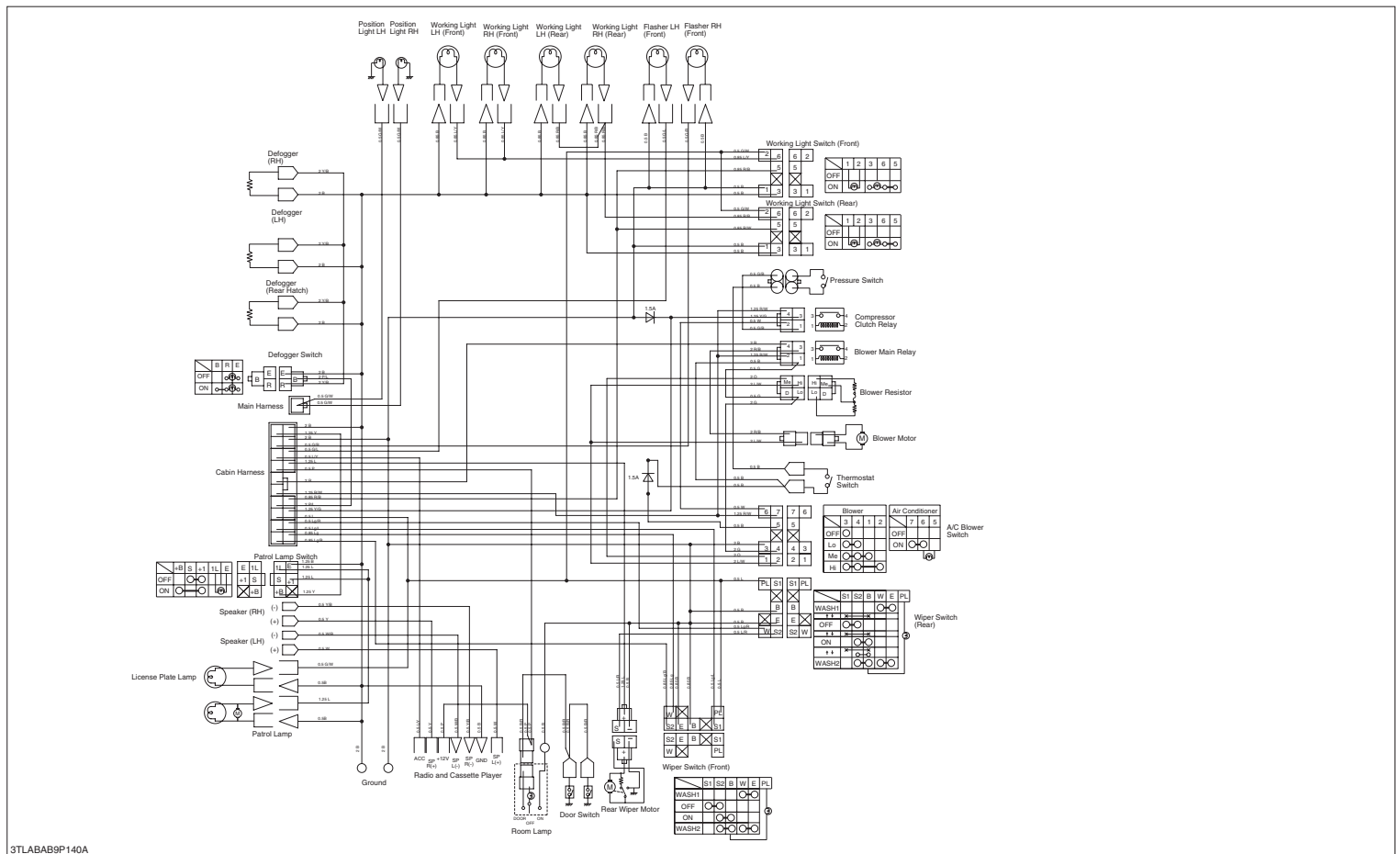

3TLABAB9P140A

9-M5

KISIC issued 02, 2007 A



**[5] COLOR OF WIRING**

B ..... Black	B/W ..... Black / White	Lg/Y ..... Light Green / Yellow
G ..... Green	B/Y ..... Black / Yellow	Or/W ..... Orange / White
L ..... Blue	Br/B ..... Brown / Black	R/B ..... Red / Black
P ..... Pink	Br/Y ..... Brown / Yellow	R/G ..... Red / Green
R ..... Red	G/B ..... Green / Black	R/L ..... Red / Blue
V ..... Violet	G/L ..... Green / Blue	R/W ..... Red / White
W ..... White	G/R ..... Green / Red	R/Y ..... Red / Yellow
Y ..... Yellow	G/W ..... Green / White	W/B ..... White / Black
Br ..... Brown	G/Y ..... Green / Yellow	W/G ..... White / Green
Lg ..... Light Green	L/B ..... Blue / Black	W/L ..... White / Blue
Or ..... Orange	L/G ..... Blue / Green	W/R ..... White / Red
Sb ..... Sky Blue	L/Or ..... Blue / Orange	W/Y ..... White / Yellow
B/G ..... Black / Green	L/R ..... Blue / Red	Y/B ..... Yellow / Black
B/L ..... Black / Blue	L/W ..... Blue / White	Y/G ..... Yellow / Green
B/P ..... Black / Pink	L/Y ..... Blue / Yellow	Y/L ..... Yellow / Blue
B/Pu ..... Black / Purple	Lg/B ..... Light Green / Blue	Y/R ..... Yellow / Red
B/R ..... Black / Red	Lg/W ..... Light Green / White	

W1019456

## 2. ELECTRONIC CONTROL PANEL

### [1] SYSTEM OUTLINE AND ELECTRICAL CIRCUIT

#### (1) System Outline



- |  |                         |
|--|-------------------------|
| (1) Combination Switch                         | (4) Hazard Switch       |
| (2) Liquid Crystal Display (LCD)               | (5) Travel Speed Switch |
| (3) Electronic Instrument Panel (IntelliPanel) | (6) Display Mode Switch |

W1012906

The Electronic Instrument Panel (IntelliPanel) adopted in the L30 series tractors consists of an 8-bit Central Processing Unit (CPU<sup>\*1</sup>), sensors and input devices, memory devices such as RAM and ROM, and others. The CPU executes multiplex-communication<sup>\*2</sup> with ECU (Electronic Control Unit) and various sensors, switches and other related devices in order to give the functions that accurately and timely provide an operator with various information necessary for tractor operation. The contents include corrective procedure in case of an erroneous operation, precautions, and various alerts. If the tractor gets in trouble, a defective location, for example, is displayed with a message (sign) on the liquid crystal display (LCD<sup>\*3</sup>) or indicated with a monitor lamp.

The messages are displayed with segments, which gives approximately 130 patterns.

In the LCD, characters appear over reflected illumination, and are always back-lit by a small yellow lamp while the main switch is "ON".

#### \*1 CPU

This CPU is the core part of computers that controls the input/output devices to receive data, processes the data, and sends out the computing results.

The CPU comes in different types : 8 bits, 16 bits, 32 bits, etc., according to the number of bits as the unit of internal data processing. In general, the larger the number is, the higher the performance is.

#### \*2 Multiplex communication

In multiplex communication, just one transmission (signal) line is effectively used to send and receive signals for digital transmission. In data communication, the transmission capacity of the line and the capacity of signal transmission/reception are represented by the number of bits that can be transmitted or received for one second. When the capacity of the transmission line is extremely larger than the ability of the transmission/reception performed by a terminal device, signals from plural terminals can be transmitted by means of time-sharing and multiplexing of one transmission path.

The merits of multiplex communication are as follows :

1. It permits high-performance control that allows three units to share information from sensors and information required for control.
2. It provides the smaller number of wire harnesses.
3. It allows each control unit to independently control the connected devices if communication should fail for some reason and become impossible.

#### \*3 LCD

LCD is a displaying device that utilizes the characteristic of liquid crystal, in which the application of voltage triggers the molecules to change their orientations. The principle of indication is that when a voltage is applied on a liquid crystal sandwiched between two glass plates, the direction of molecules changes, with the resultant variation of the oscillatory direction of light that penetrates the liquid crystal. The set-up of a polarizing plate makes light go through or get blocked according to a change in voltage. Since the use of only the polarizing plate results in peculiar color, the film to counteract colored light is superimposed. However, the liquid crystal itself does not generate light, so it is back-lit by a fluorescent tube, for example, which makes the display easy to read in a dark space.

## (2) Control Items

For HST models and manual transmission models, the electronic instrument panel (IntelliPanel) functions to receive data from sensors and switches, and displays them on the meter. For GST models, the IntelliPanel also receives data also from the GST control ECU (Electronic Control Unit) through multiplex communication, and displays them on the panel. Further, the GST control ECU receives model data and sensor data from IntelliPanel to determine the control status.

In addition, the IntelliPanel controls the following items.

### 1. Various Information Display Function

#### - Normal Display

Receive various data from each sensor, and display the hour meter, the traveling speed, the PTO speed, the fuel level, and the coolant temperature, etc. on the LCD which are basic information necessary for the tractor operation.

#### - Attention Display (at engine starting)

Display the operator's guidance of levers and pedals at the engine starting on the LCD.

#### - Service Interval Display

Display and alert the service interval periodically on the LCD and panel.

#### - Warning Display

Display the fuel level warning and overheat warning on the LCD and panel.

#### - Error Display

Display the occurrence of trouble with the sign on the LCD by the self-diagnosis function.

### 2. Lamp Control Function

Control the lighting and blinking of the warning lamp and the monitor lamp for operation.

### 3. Self-diagnosis Function

### 4. Fail-safe Function

It is a function that the entire system operates safely when the part of system gets in trouble.

### 5. Glow Control Function

### 6. Data Input, Fine-adjustment and Test Function

The function such as an input of various data, fine-adjustment of GST, and a testing of each sensor, etc. can be done by using LCD and switch operation.

## [2] CONSTRUCTION AND FUNCTION OF COMPONENTS

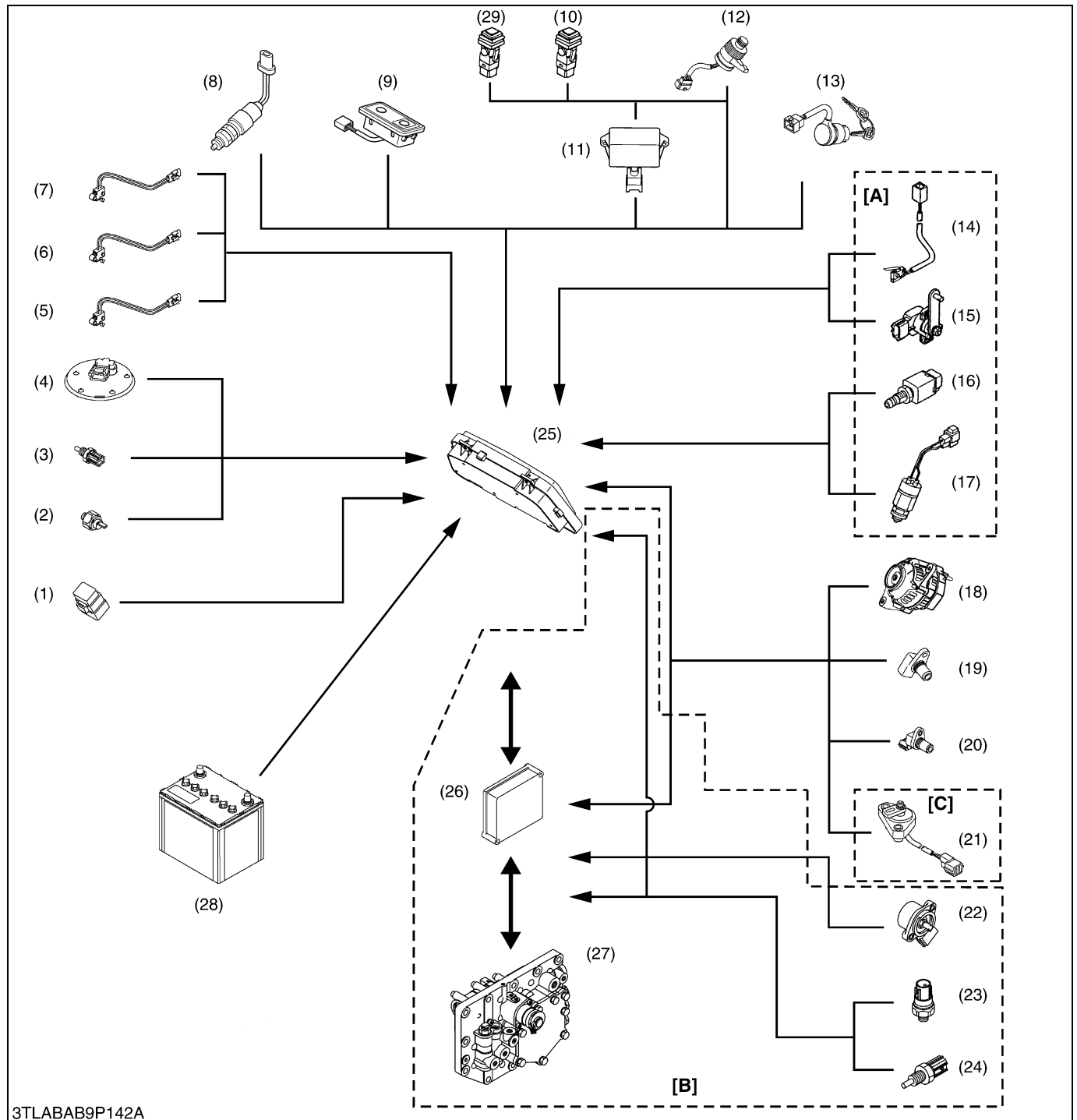

3TLABAB9P142A

- |   |                                   |   |   |
|---|-----------------------------------|---|---|
| (1) Glow Relay  | (10) Hazard Switch                | (19) Engine Tachometer Sensor                   | (27) GST Valve (Solenoid Valve and Proportional Reducing Valve) |
| (2) Engine Oil Pressure Switch                          | (11) Flasher Unit                 | (20) Traveling Speed Sensor                     | (28) Battery  |
| (3) Coolant Temperature Sensor                          | (12) Combination Switch           | (21) Shuttle Switch                             | (29) Position Switch  |
| (4) Fuel Sensor   | (13) Main Switch                  | (22) GST Lever Sensor                           |   |
| (5) PTO Switch  | (14) Cruise Switch                | (23) Oil Pressure Switch                        |   |
| (6) PTO Speed Change Switch (Manual Transmission Model) | (15) HST Range Shift Lever Sensor | (24) Oil Temperature Sensor                     |   |
| (7) Parking Brake Switch                                | (16) HST Pedal Neutral Switch     | (25) Electronic Instrument Panel (IntelliPanel) | <b>[A] For HST Model</b>  |
| (8) Parking Brake Lamp Switch                           | (17) Clutch Pedal Switch          | (26) Electronic Control Unit (ECU)              | <b>[B] For GST Model</b>  |
| (9) Display Mode Switch and Travel Speed Switch         | (18) Alternator                   |   | <b>[C] For Manual Transmission Model and GST Model</b>          |



### ■ Electronic Instrument Panel (IntelliPanel)

An 8 bit CPU is incorporated into the IntelliPanel, and outputs the status of the tractor to the LCD, monitor lamp, tachometer, and buzzer. The built-in buzzer starts sounding, interlocked with alert/failure indications as well as with indication switching, and permits to make sure of the operational status of each part.

- (1) Electronic Instrument Panel (IntelliPanel)

W1013947

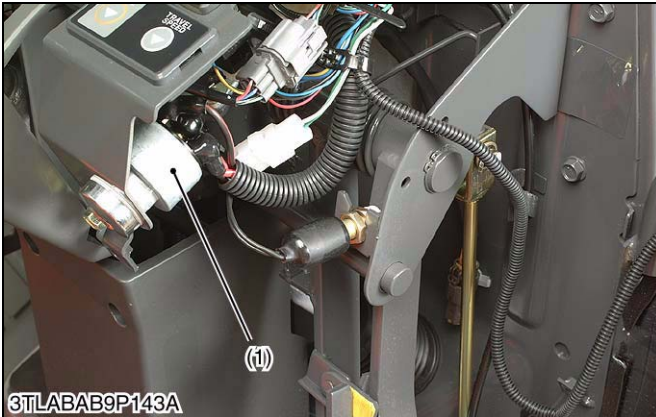

### ■ Main Switch

The main switch (1) transmits a main switch "ON" signal and an "ST" signal at the time of engine start to the IntelliPanel. When each lever switch and the associated are in the neutral position, the computer in the IntelliPanel detects the signals and determines whether the engine can be started safely.

- (1) Main Switch

W1014104



### ■ Combination Switch

The illumination lamp within the IntelliPanel lights up by the operation of the headlight switch (1), interlocked with the light-up of the headlight. When the high beam headlight is used, the monitor lamp at the panel lights up.

The pilot lamp at the panel lights up by the operation of turn signal switch (2), interlocked with the turn signal lamp flashing through the hazard unit.

- (1) Headlight Switch                      (2) Turn Signal Switch

W1014167



### ■ Hazard Switch

The pilot lamp at the panel lights up by the operation of hazard switch (1), interlocked with the hazard lamp flashing through the flasher unit.

- (1) Hazard Switch

W1014047





### ■ Position Switch

Position switch (1) is used to lighting the position lamp. The lamp in this switch is lighted up when this switch is ON.

(1) Position Switch

W1019828



### ■ Display Mode Switch and Travel Speed Switch

These switches are located at the right of the IntelliPanel and both are of tact type. Usually, the display mode switch (1) is used at the switching of display indication, and the traveling speed switch (2) is used to switching to the traveling speed display as well as at data input and fine adjustment.

(1) Display Mode Switch                      (2) Traveling Speed Switch

W1014375

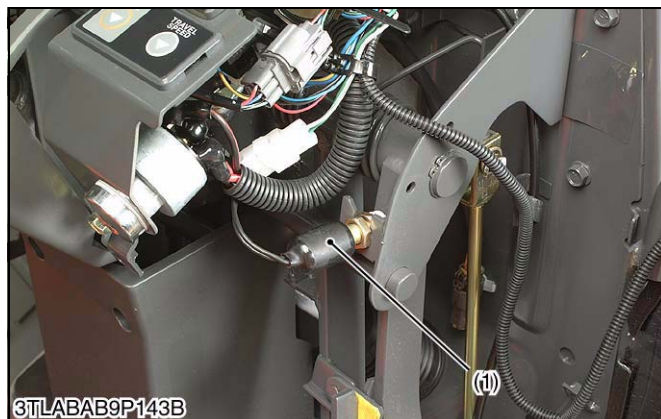

### ■ Brake Lamp Switch

This switch is mounted on the brake pedal. When the brake pedal is depressed, this switch is turned on and the brake lamp is lighting.

(1) Brake Lamp Switch

W1020505

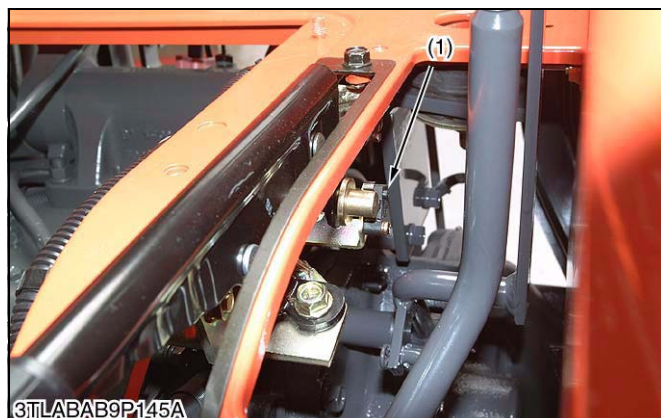

### ■ Parking Brake Switch

This switch (1) is turned on and off interlocked with the parking brake lever. It is switched on when the parking brake lever is pulled up, thereby sending a signal to light up the pilot lamp at the IntelliPanel.

(1) Parking Brake Switch

W1014449



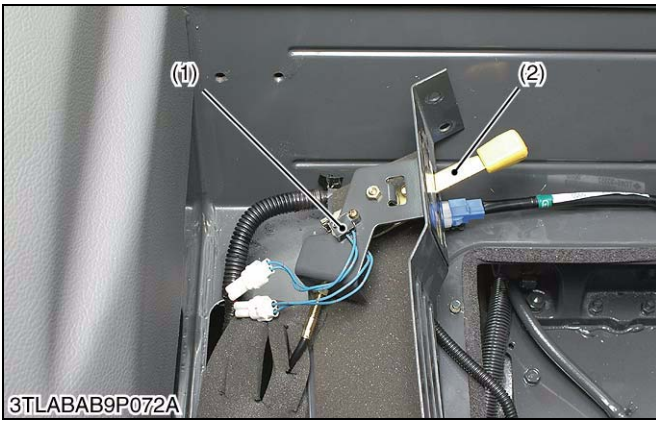

### ■ PTO Switch

This switch (1) is mounted on the PTO shift lever (2), and sends a signal to light up the lamp at the IntelliPanel when PTO is used. It also serves as a safety switch when the engine is started.

(1) PTO Switch

(2) PTO Shift Lever

W1014516

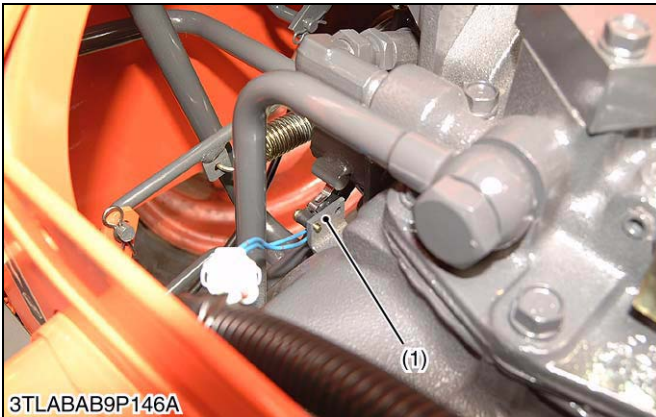

### ■ PTO Speed Change Switch : for Manual Transmission Model

This switch (1) is turned on by the PTO speed change lever operation, and sends a signal to the IntelliPanel.

(1) PTO Speed Change Switch

W1014252

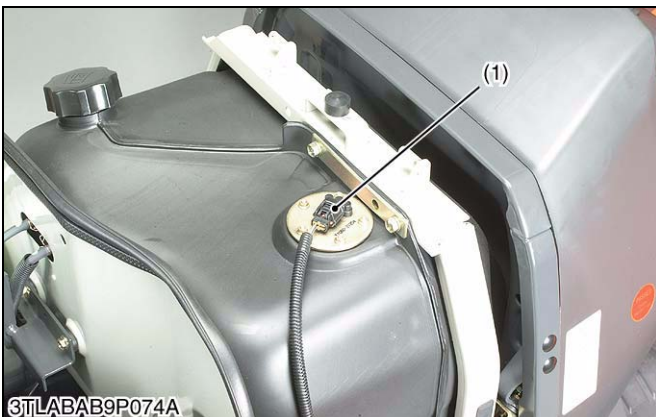

### ■ Fuel Sensor

This sensor (1) is designed to detect the fuel level in the fuel tank. It detects the position of the float that moves according to the quantity of fuel through the variation in resistance of the variable resistor, in order to indicate the fuel level on the LCD. It also sends a signal to light up the monitor lamp at the IntelliPanel when fuel becomes less than 5 L (1.3 U.S.gals, 1.1 Imp.gals).

(1) Fuel Sensor

W1014733



### ■ Coolant Temperature Sensor

This sensor (1) is designed to detect the temperature of coolant. It employs a thermistor, and detects the variation in resistance due to a change in temperature to indicate the temperature on the LCD. It also sends a signal to light up the alarm lamp in case of overheat, and indicate an alert message.

(1) Coolant Temperature Sensor

W1014804

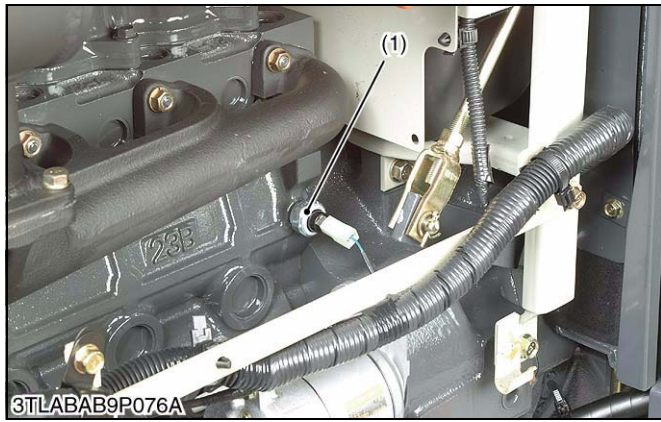

### ■ Engine Oil Pressure Switch

This switch (1) is turned on when the main switch is turned on and the engine oil pressure becomes lower than 49 kPa (0.5 kgf/cm<sup>2</sup>, 7.1 psi), and sends a signal to light up the alarm lamp.

(1) Engine Oil Pressure Switch

W1014871

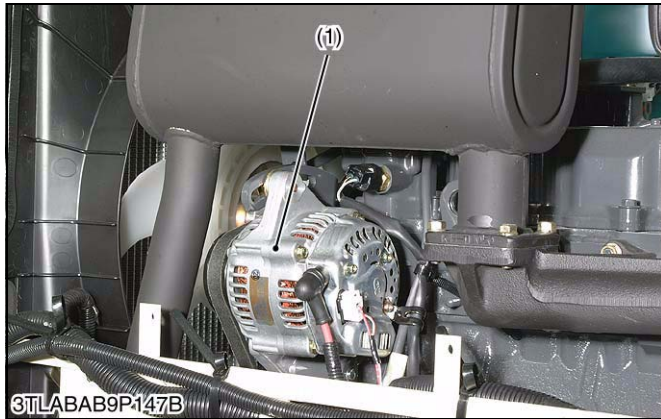

### ■ Alternator

The terminal **L** of this alternator detects a signal from the battery charge. The alternator sends a signal for making the alarm lamp at the IntelliPanel to light up if the electricity charge system becomes abnormal.

(1) Alternator

W1014934

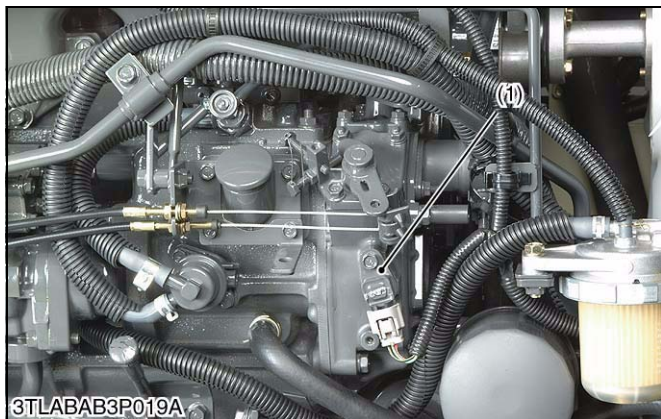

### ■ Engine Tachometer Sensor

This sensor (1) is mounted at the right side of the engine gear case, and generates pulses proportional to the rotation of the fuel camshaft and the number of the cam gear teeth. The engine speed is calculated from the frequency of the pulse. The tachometer of the IntelliPanel is of cross coil type, and analogically indicates by and after converting the frequency of the engine tachometer sensor. The PTO speed is calculated by means of using the frequency detected by this sensor and operational coefficient preset from model to model.

(1) Engine Tachometer Sensor

W1015004



### ■ Traveling Speed Sensor

This sensor (1) is mounted at the right bottom of the transmission case, and generates pulses proportional to the rotating speed and the number of teeth of the front-wheel drive gear on the PTO drive shaft. The speed of the tractor is calculated by means of using the frequency of the pulse and the operational coefficient preset for the model and tire size in question.

(1) Traveling Speed Sensor

W1015075





### ■ Glow Relay

This tractor has a system in which glow control is performed through the IntelliPanel, and controls the coil current that starts or stops the preheating circuit through the electronic meter. The time required for preheating is adjusted by means of the water temperature sensor.

(1) Glow Relay

W1015142

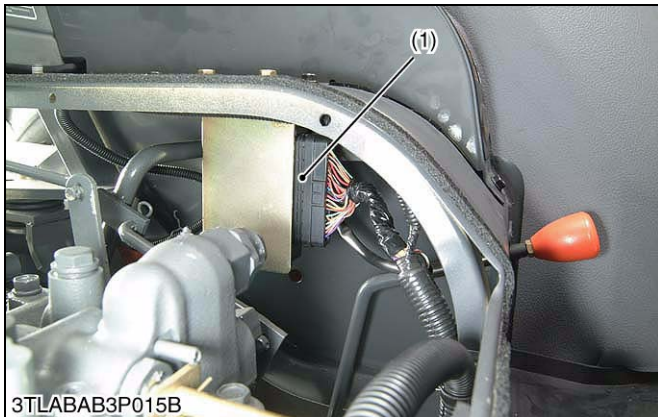

### ■ Electronic Control Unit (ECU) : for GST Model

The ECU (1) functions to operate GST in accordance with information coming from various sensors.

It has the role of controlling all the components while sharing sensor information necessary for control and control information with the IntelliPanel, and consists of 16 bit CPU and interface that corresponds to the signal inlet and outlet.

(1) Electric Control Unit (ECU)

W1015355

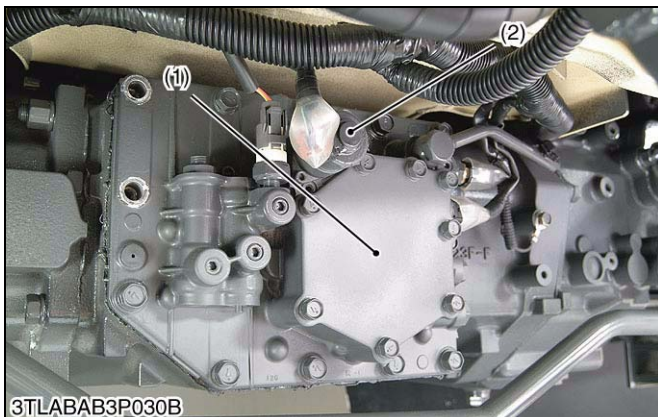

### ■ GST Valve (Solenoid Valves and Proportional Reducing Valve) : for GST Model

This valve (1) includes the sensors and switches and the associated necessary for GST control, solenoid that actuates GST, shift pin, proportional reducing valve, and others. It sends information from sensors and the associated to ECU, and then a signal from ECU actuates each solenoid valve.

(1) GST Valve Assembly

(2) Proportional Reducing Valve

W1015434

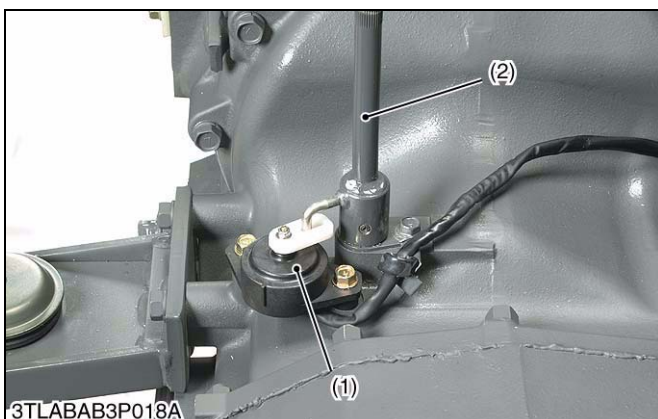

### ■ Shuttle Switch : for Manual Transmission and GST Model

This switch (1) is mounted at the bottom of the shuttle lever shaft (2) and is turned on when the position of **F**, **N**, or **R** is detected through the movement of the sensor lever, thereby outputting a 12 V signal to the IntelliPanel and ECU.

It also serves as a safety switch when the engine is started.

(1) Shuttle Switch

(2) Shuttle Lever Shaft

W1015505



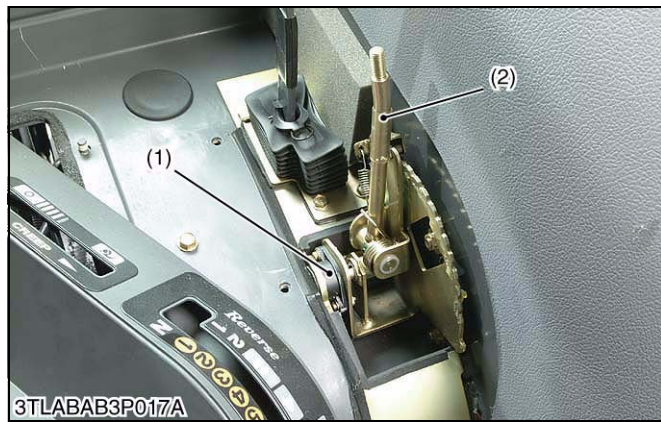

#### ■ GST Lever Sensor : for GST Model

This sensor (1) is designed to detect the position at which the GST lever changes speed, and is mounted at the bottom of the GST lever (2). It has the variable resistor of revolution angle type, the maximum resistance value is 2 k $\Omega$ , and the electrically effective angle is 140 degrees. It also outputs the position of the lever from N to 12th speed stage in the range of approximately 0.5 to 3.5 V, and then sends a signal to the IntelliPanel and ECU.

(1) GST Lever Sensor                      (2) GST Lever

W1015572



#### ■ Oil Pressure Switch : for GST Model

This switch (1) is designed to detect that the gear shift completion of GST and pressurizing of GST clutch pressure, and is mounted at the side of GST valve. It is turned on when the pilot pressure has become higher than 0.49 MPa (5 kgf/cm<sup>2</sup>, 71 psi) and is turned off when the pressure has become lower than 0.34 MPa (3.5 kgf/cm<sup>2</sup>, 50 psi).

(1) Oil Pressure Switch

W1015635



#### ■ Oil Temperature Sensor : for GST Model

This sensor (1) is designed to detect the temperature of transmission oil and is mounted at the side of GST valve. It is provided in order to compensate the operating time and electric current of the proportional reducing valve within GST valve, according to the transmission oil temperature.

The sensor employs the thermistor in which a rise in oil temperature causes smaller resistance and a fall in the temperature causes larger one.

(1) Oil Temperature Sensor

W1015709

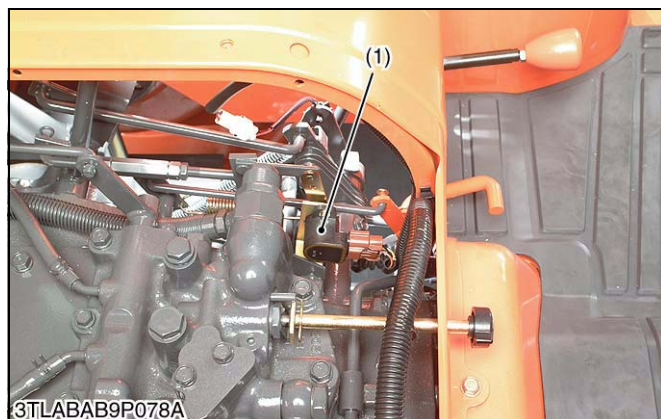

#### ■ HST Range Gear Shift Lever Sensor : for HST Model

This sensor (1) is designed to detect the position at which the HST range gear shift lever changes the speed, and is mounted at the bottom of the lever.

It has the variable resistor of revolution angle type, and the maximum resistance value is 5.4 k $\Omega$ . It outputs the lever position of **L**, **M**, **N** or **H** in the range of approximately 1.0 to 4.0 V.

(1) HST Range Gear Shift Lever  
Sensor

W1015780

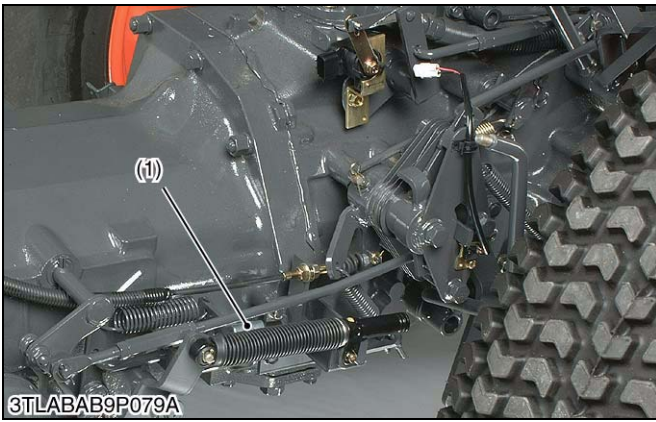

#### ■ HST Pedal Neutral Switch : for HST Model

This switch (1) is mounted on the HST pedal link, and is turned on when the HST pedal is in the neutral position. It serves as a safety switch when the engine is started.

(1) HST Pedal Neutral Switch

W1015847

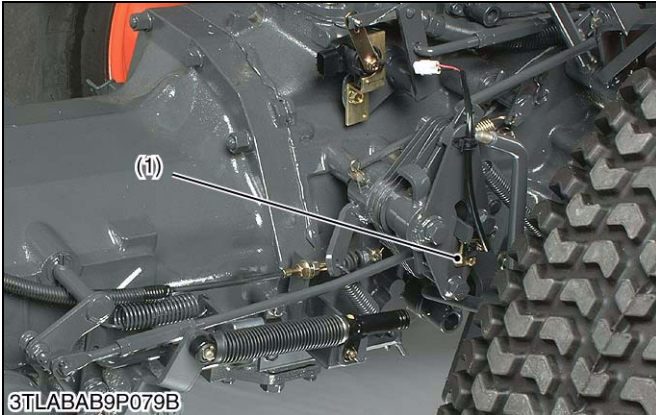

#### ■ Cruise Control Switch : for HST Model

This switch (1) is mounted at the bottom of the cruise lever assembly, and is turned on when the lever is operated, thereby sending a signal to light up the pilot lamp at the electronic instrument panel.

(1) Cruise Control Switch

W1015910

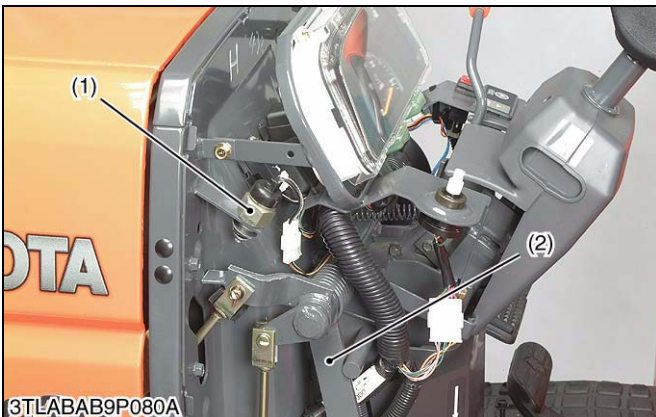

#### ■ Clutch Pedal Switch : for HST Model

This switch (1) is mounted close to the fulcrum of the clutch pedal, and is turned on when the pedal is depressed (clutch "OFF"). It serves as a safety switch when the engine is started.

(1) Clutch Pedal Switch

(2) Clutch Pedal

W1014615



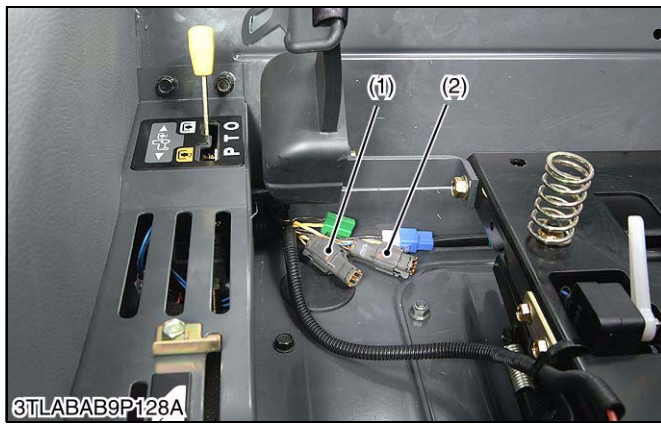

### ■ Emergency Connector : for GST Model

This is a device which compulsorily operates the shift solenoid when the tractor does not move due to the trouble of the GST system and moves the tractor.

#### (Situation for necessity of emergency connector)

- The defect in ECU
- The tractor does not move at all even if the shuttle lever and GST lever are operated though the trouble is repaired.

#### (Use of emergency connector)

1. Stop the engine.
2. Disconnect the ECU connector (3).
3. Remove the each cap from connectors (1), (2).
4. Connect the connector **A** and **B**.
5. Start the engine and move the tractor.

#### ■ NOTE

- When connecting the emergency connectors, the GST valve is set at 1st speed position even if the GST lever is at any position. And the stop and the start of the tractor is operated by shuttle lever.

#### ■ IMPORTANT

- Be sure to disconnect the ECU connector when using the emergency connector.

- (1) Emergency Connector A      (3) ECU Connector  
 (2) Emergency Connector B

W1031207



### [3] CONTROL SYSTEM

#### (1) Basic Control System

##### (A) Normal Display

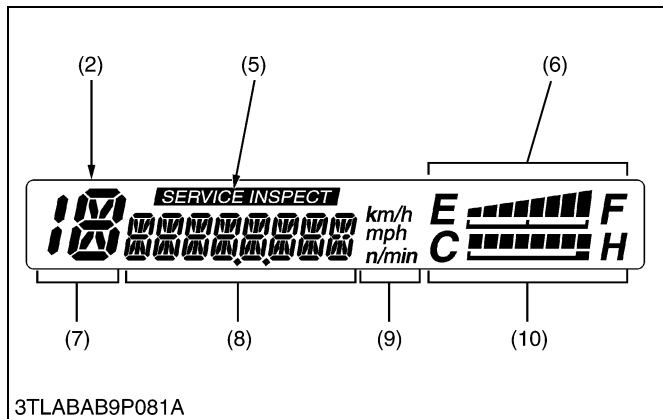

The normal display is a message indicated in the liquid crystal display (LCD) while the main switch is turned **ON** or the engine is starting.

The fuel gauge and coolant temperature gauge are always displayed on a right edge of LCD, and the position of gear shifting is displayed on a left edge for GST and HST model.

By pushing the display mode switch (3), it is switched to five kinds of displays shown in the table below.

- |  |  |
|--|--|
| (1) IntelliPanel (Electronic Instrument Panel) | (6) Fuel Gauge   |
| (2) Liquid Crystal Display (LCD)               | (7) Selected Speed Indication (HST and GST Model Only) |
| (3) Display Mode Switch                        | (8) Message Display                                    |
| (4) Travel Speed Switch                        | (9) Unit Indication                                    |
| (5) Periodic Service Required Readout          | (10) Coolant Temperature Gauge                         |

W1017233

Procedure	Display Item	Manual Transmission Model	GST Model	HST Model
1	Normal Display 1 Hour Meter (Multiplication hours)			
2	Normal Display 2 Trip Meter (Unit hours)			
3	Normal Display 3 Traveling Speed (mph)			
4	Normal Display 4 Traveling Speed (km/h)			
5	Normal Display 5 PTO Speed (PTO OFF)			
	(PTO ON)*1			
6	Return to Top			

**NOTE**

- Trip meter can be reset to 0.0 h by pushing and holding the display mode switch for about two seconds with trip meter displayed.

\*1 : Let's suppose that the PTO gear shift lever is at the neutral position. When you turn ON the PTO clutch control lever, the PTO shaft stays off but the meter displays the rpm at the L position. This is normal, not a machine failure.

W1015278

## (B) Attention Display (At Engine Starting)

If neither of the levers or pedals are in neutral positions when the main switch is turned to the “**START**” position, the engine cannot be started. The IntelliPanel displays a message for the operator to correct the situation by placing the appropriate lever or pedal in the neutral position.

### ■ Manual Transmission and GST Model

The safety switch for engine starting is adapted for the shuttle lever and the PTO shift lever in these models.

#### (Reference)

- As for the manual transmission model, selected speed displayed on left edge is not indicated.

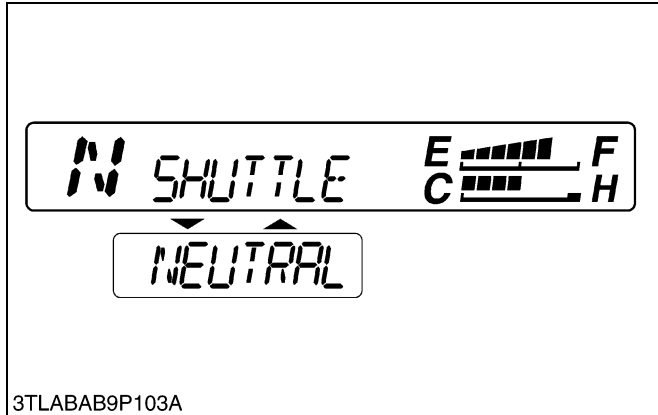

### ■ When the shuttle lever is not set at a Neutral position

Shift the shuttle lever to **Neutral** position.

W1017623

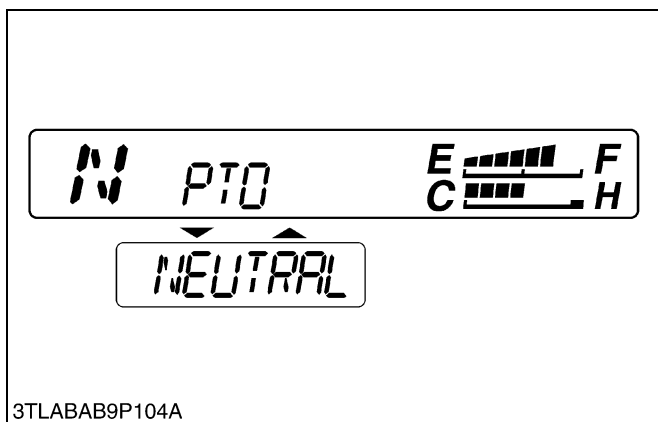

### ■ When the PTO shift lever is not set at a Neutral Position

Shift the PTO shift lever to **Neutral** position.

W1017667

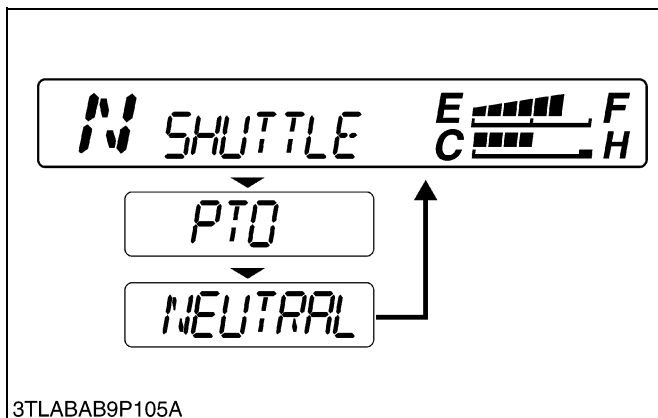

### ■ When both the shuttle lever and the PTO shift lever are not set at a Neutral position

Shift both shuttle lever and PTO shift lever to **Neutral** position.

W1017711

### ■ HST Model

The safety switch for engine starting is adapted for HST pedal, PTO shift lever and clutch pedal in this model.

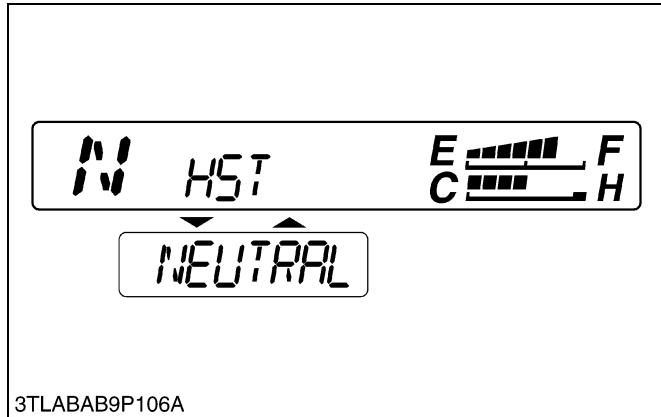

### ■ When the HST pedal is not set at a Neutral position

Release the HST pedal to set the **Neutral** Position.

W1017819

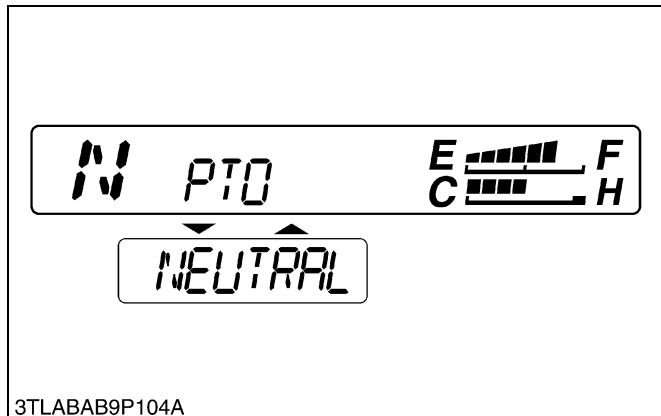

### ■ When the PTO shift lever is not set at a Neutral position

Shift the PTO shift lever to **Neutral** position.

W1017869

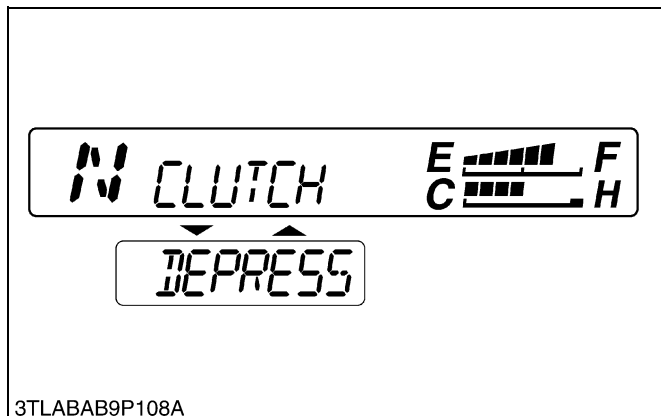

### ■ When the clutch pedal is not depressed

Depress the clutch pedal.

W1017913

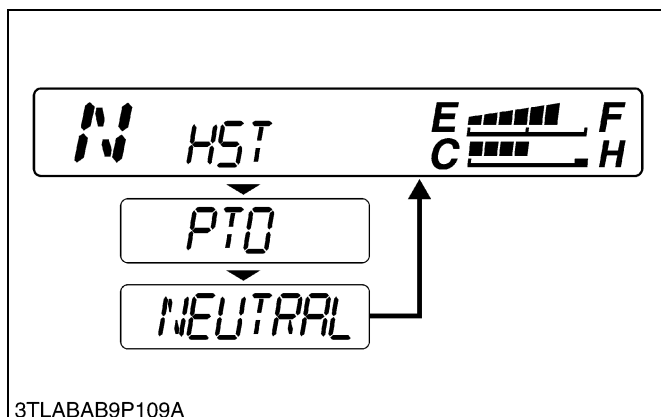

### ■ When the HST pedal and PTO shift lever are not set a Neutral position

Release the HST pedal and shift the PTO shift lever to set the **Neutral** position.

W1017957

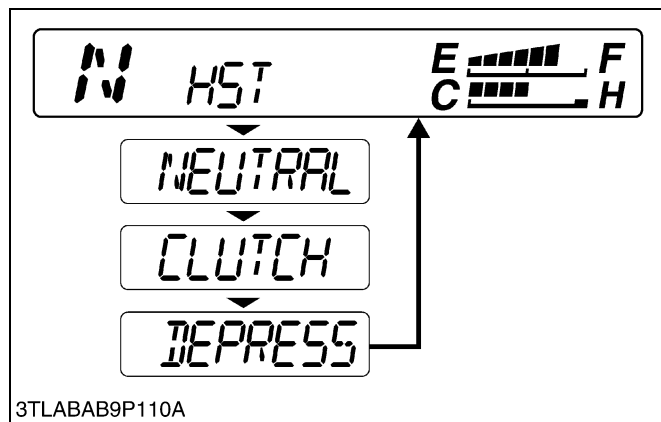

- When the HST pedal is not set at a Neutral position and the clutch pedal is not depressed

Release the HST pedal to set **Neutral** position and depress the clutch pedal.

W1018012

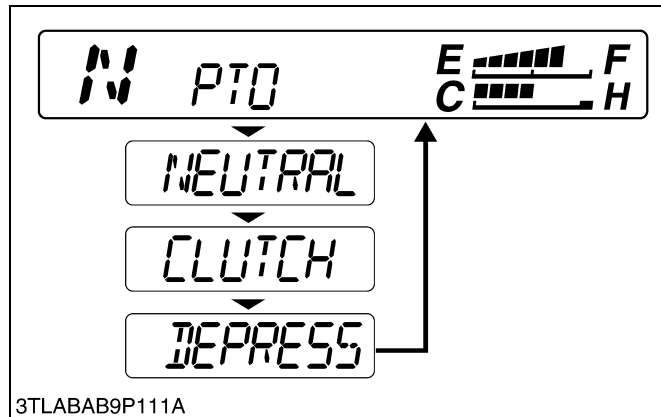

- When the PTO shift lever is not set a Neutral position and the clutch pedal is not depressed

Shift the PTO shift lever to **Neutral** position and depress the clutch pedal.

W1018064

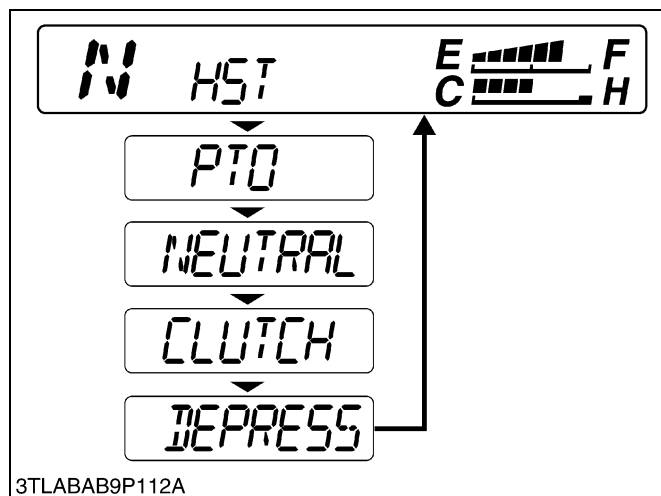

- When the HST pedal and PTO shift lever are not set a Neutral position, and clutch pedal is not depressed

Release the HST pedal and shift the PTO shift lever to set a **Neutral** position, and depress the clutch pedal.

W1017516

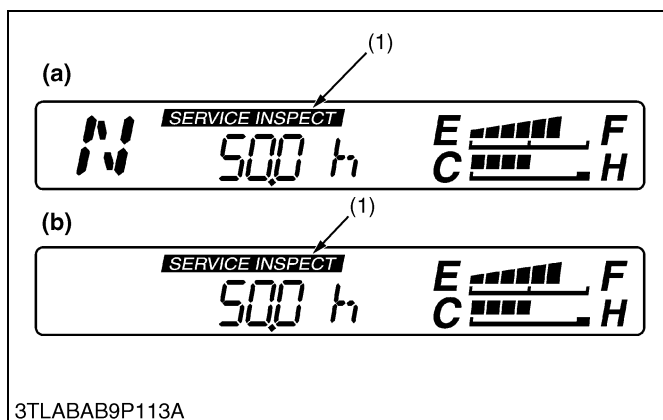
**(C) Service Interval Alert**

The IntelliPanel display will alert the operator when the scheduled service is required.

**■ IMPORTANT**

- This display, **SERVICE INSPECT**, informs the operator that periodic maintenance service is due. It does not indicate system or product malfunction.

“SERVICE INSPECT” (1), is displayed in the LCD and the service indicator lamp (2) illuminates every 50 hours. This service alert indicator remains illuminated until the clearing operation is completed after the periodic maintenance is performed.

**(Reference)**

- It is possible to change to other standard display by pushing the display mode switch (3).

**Clearing Operation :**

- Keep pushing both switches (3), (4) for two seconds or more while displaying the hour meter (Normal Display 1).

- (1) Periodic Service Required Readout
- (2) Service Indicator Lamp
- (3) Display Mode Switch
- (4) Travel Speed Switch

- (a) GST and HST Model
- (b) Manual Transmission Model

W1018218

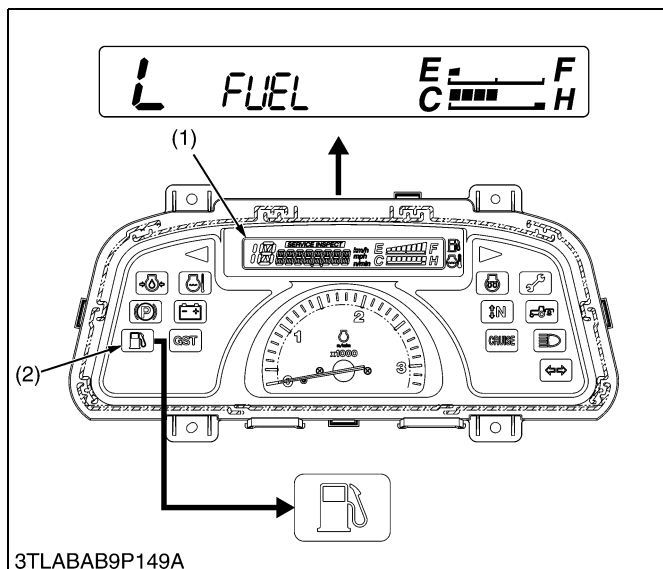
**(D) Warning Display or Warning Information****■ Fuel Level Warning**

If the fuel in the tank goes below the prescribed level (less than 5 L, 1.3 U.S.gals, 1.1 Imp.gals), “FUEL” is displayed on the LCD (1) and the warning lamp (2) in the panel will come on. If this should happen during operation, refuel as soon as possible.

It is possible to return to Normal Display by pushing the display mode switch even if “FUEL” is displayed.

- (1) Liquid Crystal Display (LCD)
- (2) Fuel Level Warning Lamp

W1018698

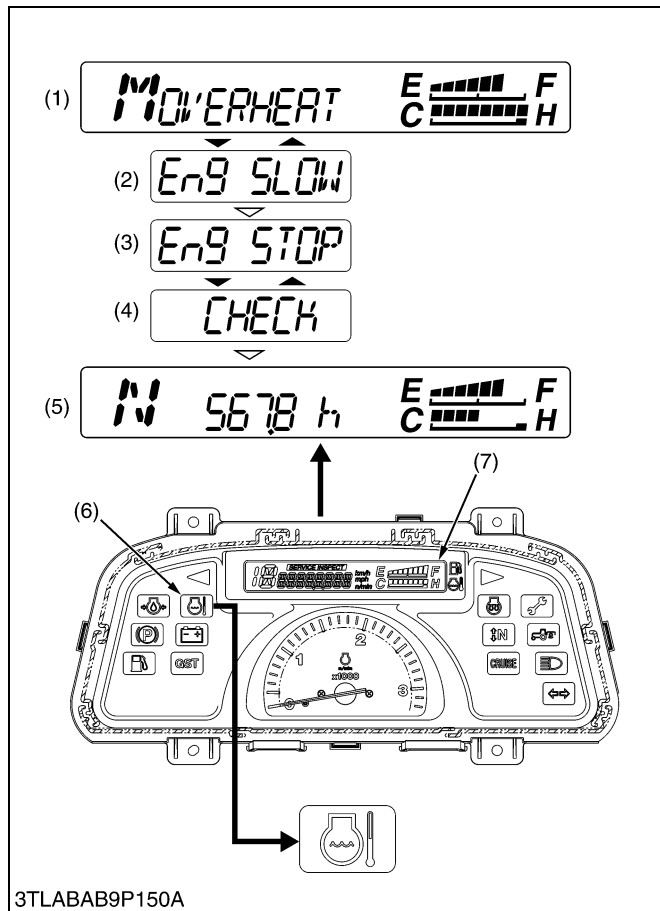

■ Overheating Warning

The IntelliPanel perceive the rise of coolant temperature, and has the function to display the overheat warning on the LCD.

When the coolant temperature becomes 125 °C (257 °F) or more, “OVERHEAT” (1) and “Eng SLOW” (2) are alternately displayed. Therefore, when these are displayed, lower the engine speed at once according to the message.

When the coolant temperature becomes 110 °C (230 °F) or less, “Eng STOP” (3) and “Check” (4) are alternately displayed. Therefore, when these are displayed, stop the engine and check the related place.

When the coolant temperature becomes 100 °C (212 °F) or less, Normal Display is displayed.

The warning lamp (6) comes on when the overheat display-1 (1) is displayed, and it keeps being on until water temperature is becoming 100 °C (212 °F) or less.

- (1) Overheat Display-1
- (2) Overheat Display-2
- (3) Overheat Display-3
- (4) Overheat Display-4
- (5) Normal Display
- (6) Overheat Warning Lamp
- (7) Liquid Crystal Display (LCD)

W1018762

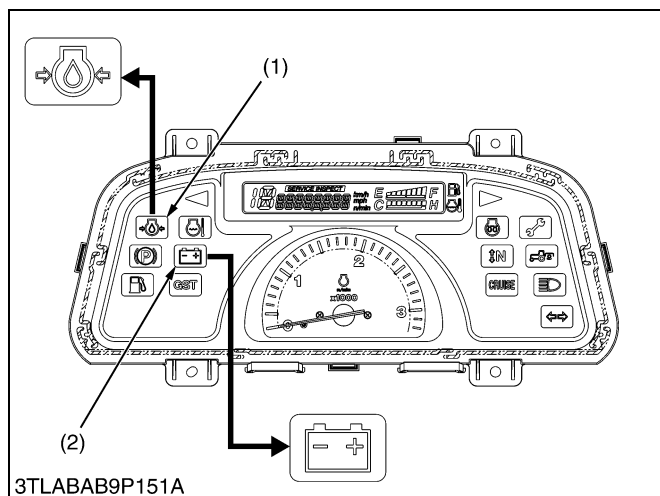

■ Engine Oil Pressure and Electric Charging Warning

If the engine oil pressure goes below the 49 kPa (0.5 kgf/cm<sup>2</sup>, 7.1 psi), the warning lamp (1) will come on. If this should happen during operation, and it does not go off when the engine is accelerated to more than 700 min<sup>-1</sup> (rpm), check level of engine oil.

If the alternator is not charging the battery, warning lamp (2) will come on. If this should happen during operation, check the charging system.

At above-mentioned the warning lamp’s lighting, and it informs warning.

- (1) Engine Oil Pressure Warning Lamp
- (2) Electric Charging Warning Lamp

W1018641

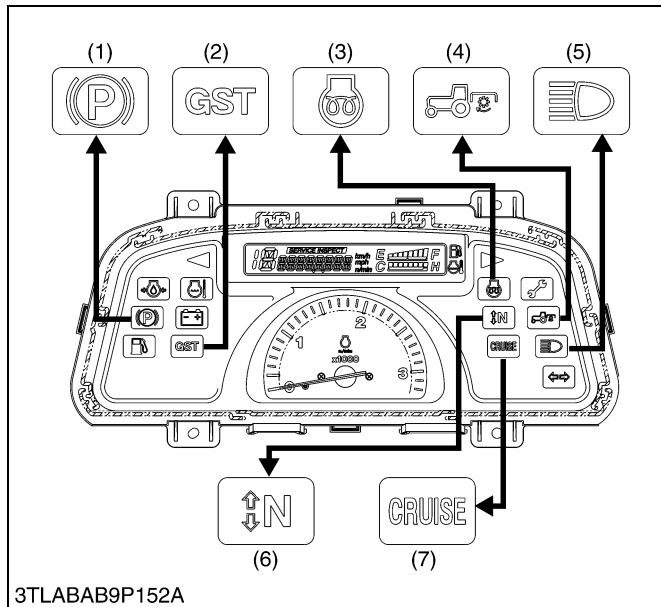

**(E) Lamp Control**

In this IntelliPanel, the control of various monitor lamps shown in figure are equipped in addition to warning lamps.

**(1) Parking Brake Lamp**

If the parking brake is applied, parking brake switch is turned on and monitor lamp will come on.

**(2) GST Warning Indicator Lamp (GST Model Only)**

If there have electrically problem in GST system, the GST warning indicator lamp will come on.

**(3) Glow Indicator Lamp**

If the main switch is turned to "ON" position, the glow indicator lamp comes on, and goes off automatically when preheating is completed.

**(4) Rear PTO Lamp**

If the PTO shift lever is "ON" position, PTO switch is turned on, and monitor lamp will come on.

**(5) High Beam Indicator Lamp**

If the head light switch is turned to High beam position, the indicator lamp comes on.

**(6) Shuttle Neutral Lamp**

**(Manual and GST Model Only)**

If the shuttle lever is set a **Neutral** position, this monitor lamp will come on.

**(7) Cruise Lamp (HST Model Only)**

If the cruise control lever is at speed set position, the cruise lamp will come on.

W1019091

## (2) Assistant Control System

### (A) Fail-safe Function

If a sensor or solenoid valve of the system gets in trouble during operation, an error message appears in the LCD screen of the IntelliPanel. The entire system adjusts itself on the safer side and keeps itself from getting into another trouble.

What's more, if the shift solenoid valve of the GST valve gets in trouble, the system adjusts itself to an accessible shift position or the neutral position no matter which position the shift lever stays in.

### (B) Self-diagnosis Function

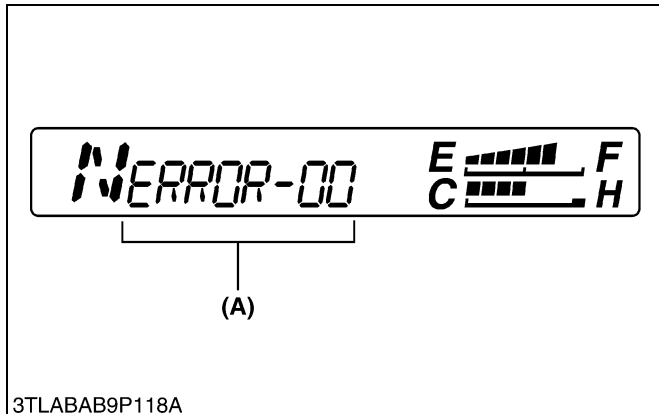

If any of the following troubles occurs, its related error code gets displayed flashing in the panel's LCD screen as shown in figure. With the repair finished, the error code disappears. The error information will be, however, put in the memory device of the IntelliPanel and can be reviewed in the Error Information Display Mode (see page 9-S18). Such error information can also be deleted out of the error history by operating of Error Information Reset Mode (see page 9-S15).

#### (Error Messages)

##### ■ For All Models

**ERROR-00** : Electronic meter in trouble

**ERROR-20** : Communication error (For GST model)  
GST-specified meter wrongly installed  
on HST or Manual Transmission Model

##### ■ For GST Model Only

**ERROR-30** : ECU in trouble

**ERROR-40** : Power supply of sensor from ECU in  
trouble

**ERROR-50** : GST lever sensor in trouble

**ERROR-60** : Proportional reducing valve in trouble

**ERROR-61** : Shift solenoid 1 in trouble

**ERROR-62** : Shift solenoid 2 in trouble

**ERROR-63** : Shift solenoid 3 in trouble

**ERROR-64** : Shift solenoid 4 in trouble

**ERROR-65** : Shift solenoid 6 in trouble

**ERROR-66** : Shift solenoid 5 in trouble

##### ■ NOTE

- See page 9-S4 about a detailed content of the error messages and their action method.

(A) The error message is  
displayed here.

W1019431

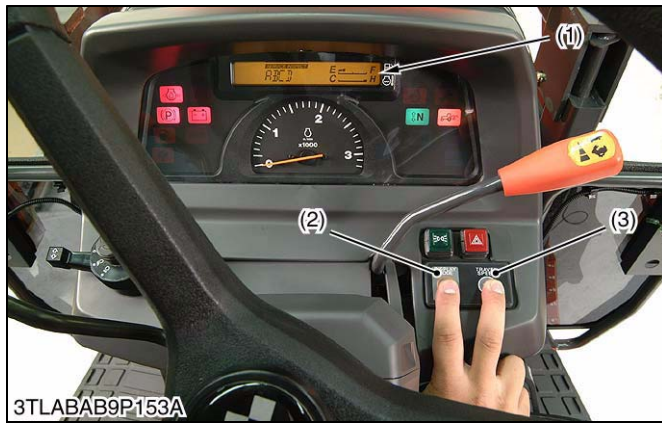
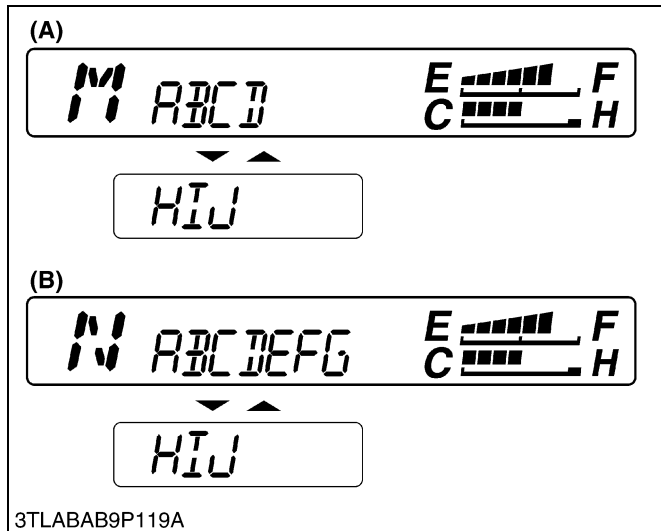
**(C) Testing, Setting and Adjusting Function**

It can do various settings, adjustments and testing by using the electronic instrument panel (IntelliPanel).

When the main switch is turned to **ON** or **START** position while pushing both the display mode switch (2) and the travel speed switch (3), the mode selection display as shown in figure is indicated. And then, a target mode is selected, the data input and the fine adjustment, etc. can be done.

The following table shows the content of each mode display by the alphabet.

Sign	Mode Name	Contents
<b>A</b>	Test Mode	For checking the sensors, battery voltage and engine revolution
<b>B</b>	Traveling Speed Coefficient Input Mode	For inputting operation coefficient of traveling speed to IntelliPanel
<b>C</b>	PTO Coefficient Number Input Mode	For inputting operation coefficient number of PTO to IntelliPanel
<b>D</b>	Error Information Reset Mode	For deleting the error information
<b>E</b>	GST Lever Sensor Fine-adjustment Mode	For setting the Neutral position of GST lever sensor (Input the sensor information to ECU)
<b>F</b>	GST Valve Fine-adjustment Mode	For setting the function of proportional reducing valve (Input the valve information to ECU)
<b>G</b>	GST Shift Shock Fine-adjustment Mode	For adjusting the clutch engaging interval
<b>H</b>	Error Information Display Mode	For reviewing error information (history)
<b>I</b>	Transmission Model Input Mode	For inputting the transmission model to IntelliPanel
<b>J</b>	Speed Unit Input Mode	For inputting the unit of traveling speeds to IntelliPanel

- (1) LCD  
 (2) Display Mode Switch  
 (3) Travel Speed Switch

- (A) Mode Selection Display for HST and Manual Transmission Model**  
**(B) Mode Selection Display for GST Model**

W1019768

## (D) Glow Control

The electronic meter incorporates the glow control which was external single parts so far, and controls it with CPU.

When the main switch is turned **ON**, the temperature of the coolant is detected with the coolant temperature sensor, and the time to supply current to the glow plug and the glow indicator lamp is controlled by CPU according to the detected temperature. And the supply current to the glow plug is stopped automatically when the preheating time is completed, and monitor lamp on the electronic meter panel is turned off. (Refer to “**STARTING SYSTEM**”.)

## 3. STARTING SYSTEM

### [1] MANUAL ROPS MODEL

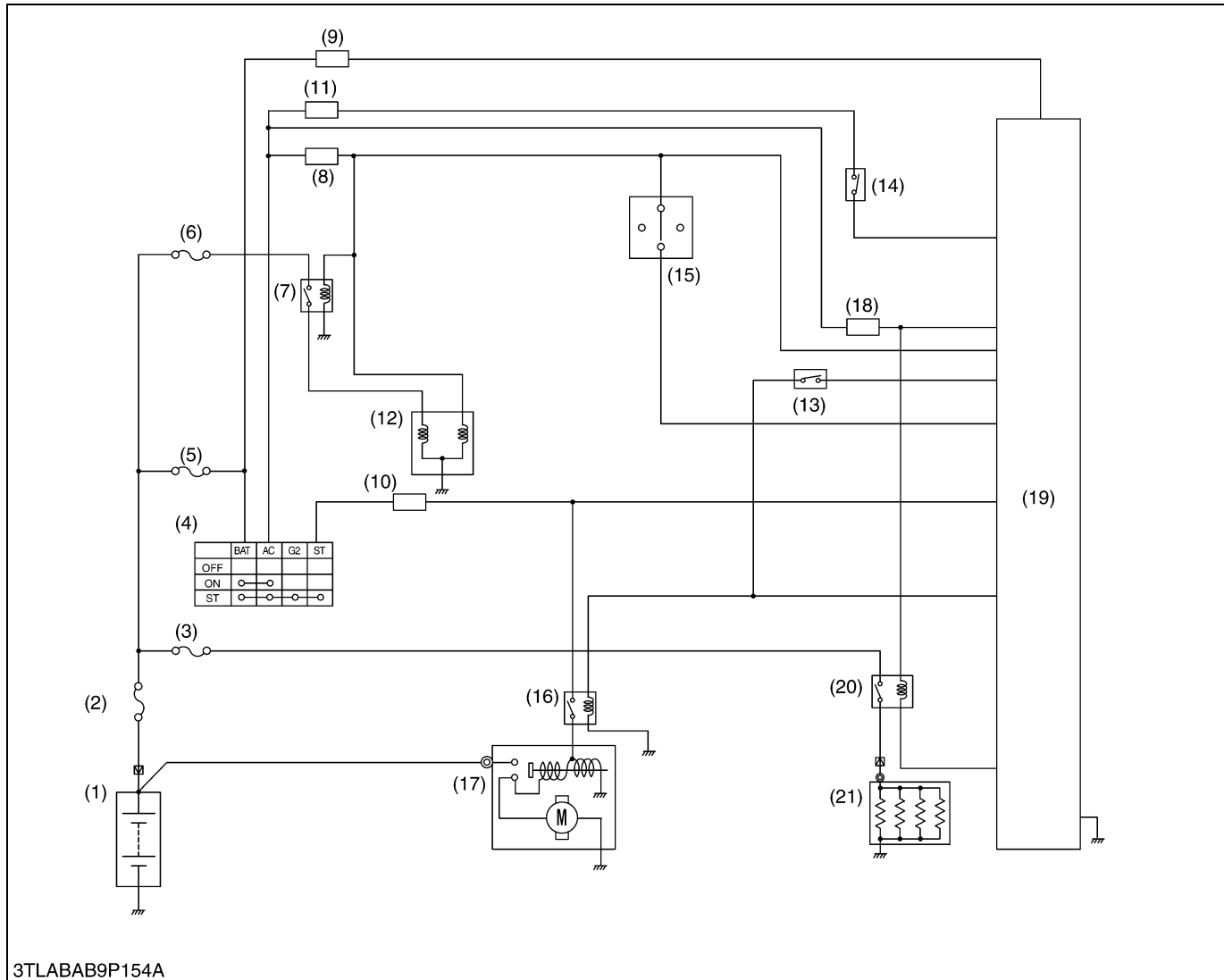

- |                           |                             |                              |   |
|---------------------------|-----------------------------|------------------------------|---|
| (1) Battery               | (7) Key Stop Solenoid Relay | (13) PTO Switch              | (18) Fuse (7.5 A)                               |
| (2) Slow Blow Fuse (60 A) | (8) Fuse (5 A)              | (14) PTO Speed Change Switch | (19) Electronic Instrument Panel (IntelliPanel) |
| (3) Slow Blow Fuse (40 A) | (9) Fuse (5 A)              | (15) Shuttle Switch          | (20) Glow Relay                                 |
| (4) Main Switch           | (10) Fuse (30 A)            | (16) Starter Relay           | (21) Glow Plug                                  |
| (5) Slow Blow Fuse (50 A) | (11) Fuse (5 A)             | (17) Starter                 |   |
| (6) Slow Blow Fuse (30 A) | (12) Key Stop Solenoid      |                              |   |

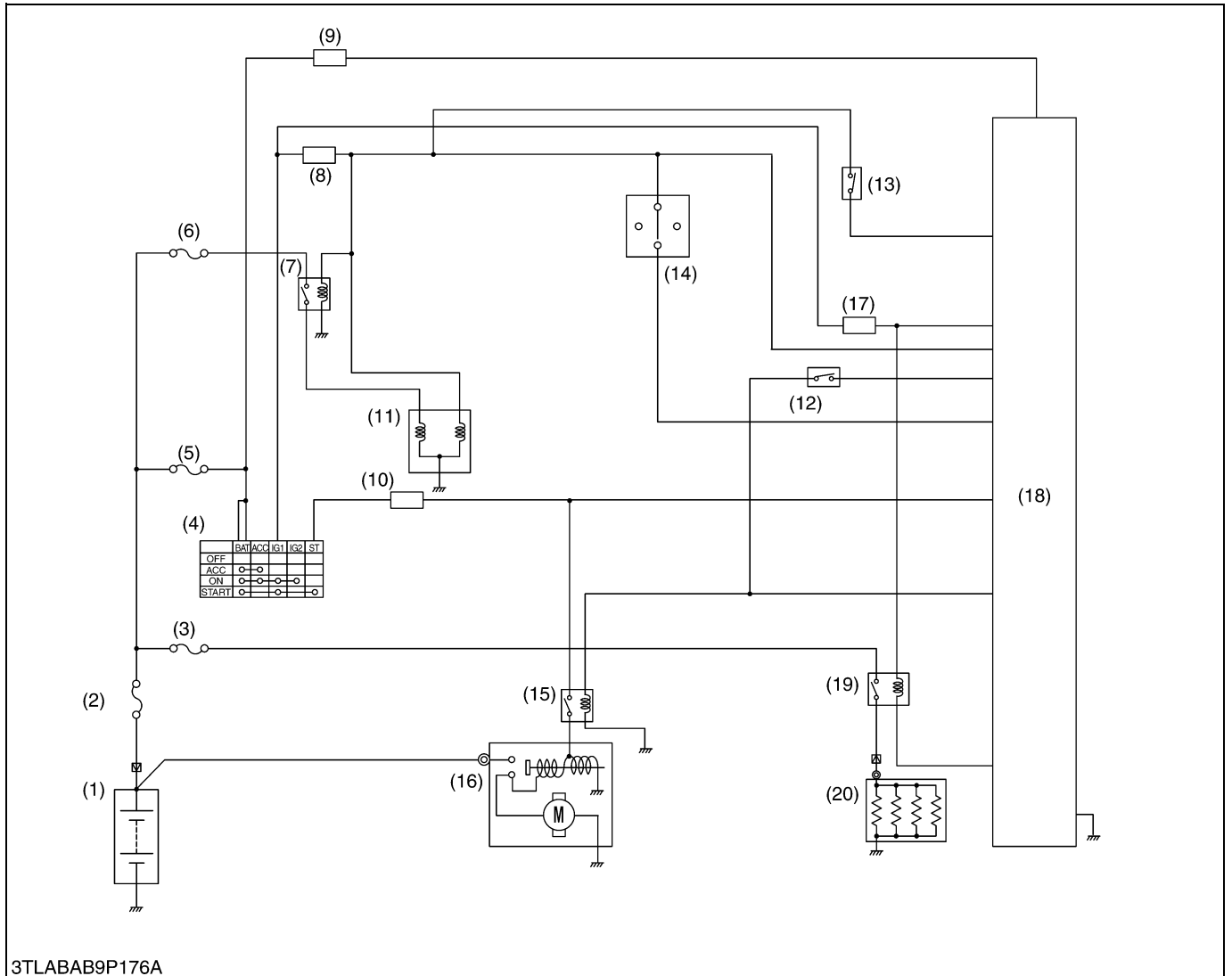
**[2] MANUAL CABIN MODEL**

- |                           |                             |                              |   |
|---------------------------|-----------------------------|------------------------------|---|
| (1) Battery               | (7) Key Stop Solenoid Relay | (12) PTO Switch              | (17) Fuse (7.5 A)                               |
| (2) Slow Blow Fuse (80 A) | (8) Fuse (5 A)              | (13) PTO Speed Change Switch | (18) Electronic Instrument Panel (IntelliPanel) |
| (3) Slow Blow Fuse (50 A) | (9) Fuse (5 A)              | (14) Shuttle Switch          | (19) Glow Relay                                 |
| (4) Main Switch           | (10) Fuse (30 A)            | (15) Starter Relay           | (20) Glow Plug                                  |
| (5) Slow Blow Fuse (60 A) | (11) Key Stop Solenoid      | (16) Starter                 |   |
| (6) Slow Blow Fuse (30 A) |                             |                              |   |

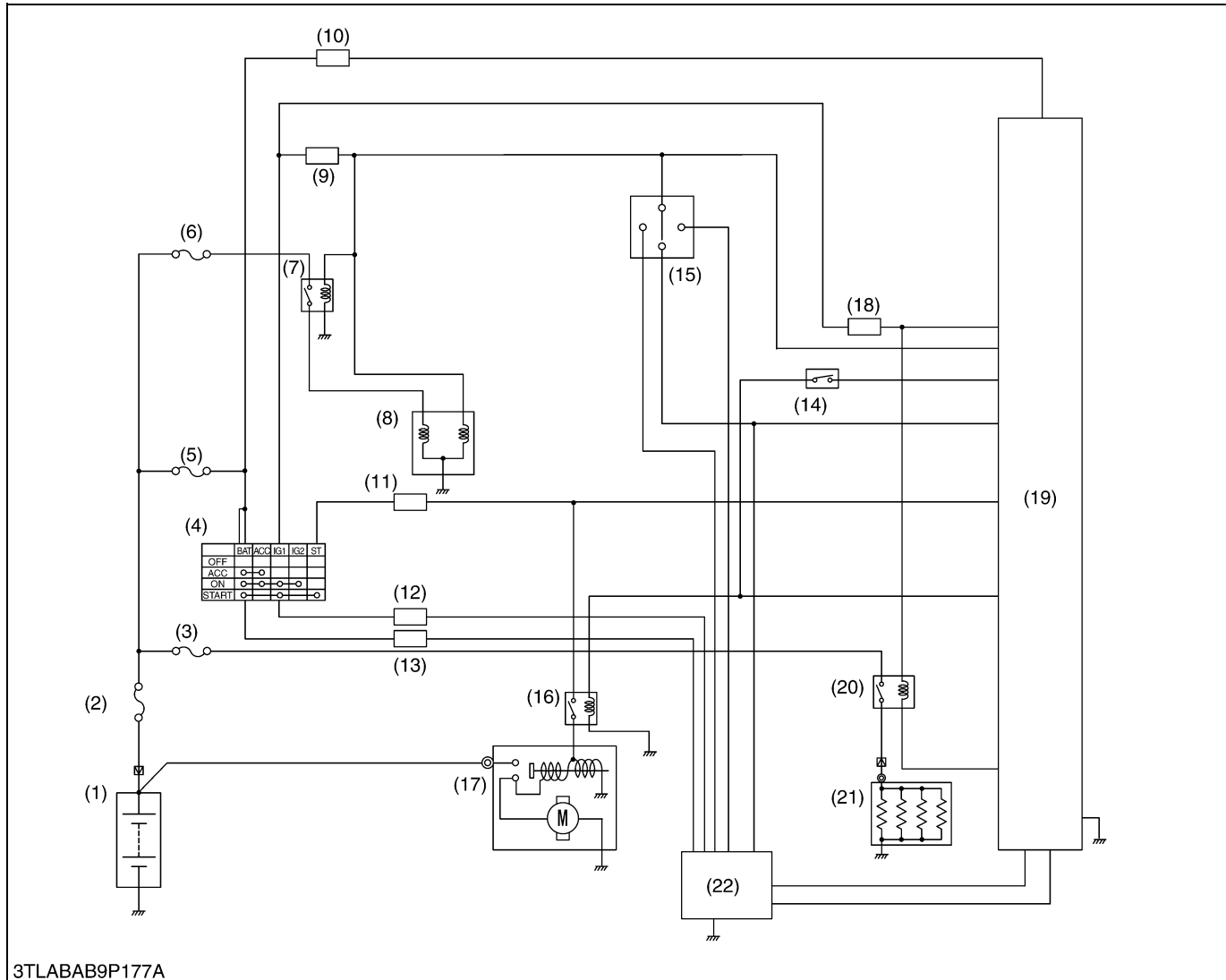

**[3] GST MODEL**

- |                             |                       |                     |   |
|-----------------------------|-----------------------|---------------------|---|
| (1) Battery                 | (8) Key Stop Solenoid | (14) PTO Switch     | (19) Electronic Instrument Panel (IntelliPanel) |
| (2) Slow Blow Fuse (80 A)   | (9) Fuse (5 A)        | (15) Shuttle Switch | (20) Glow Relay                                 |
| (3) Slow Blow Fuse (50 A)   | (10) Fuse (5 A)       | (16) Starter Relay  | (21) Glow Plug                                  |
| (4) Main Switch             | (11) Fuse (30 A)      | (17) Starter        | (22) Electronic Control Unit (ECU)              |
| (5) Slow Blow Fuse (60 A)   | (12) Fuse (10 A)      | (18) Fuse (7.5 A)   |   |
| (6) Slow Blow Fuse (30 A)   | (13) Fuse (5 A)       |                     |   |
| (7) Key Stop Solenoid Relay |                       |                     |   |

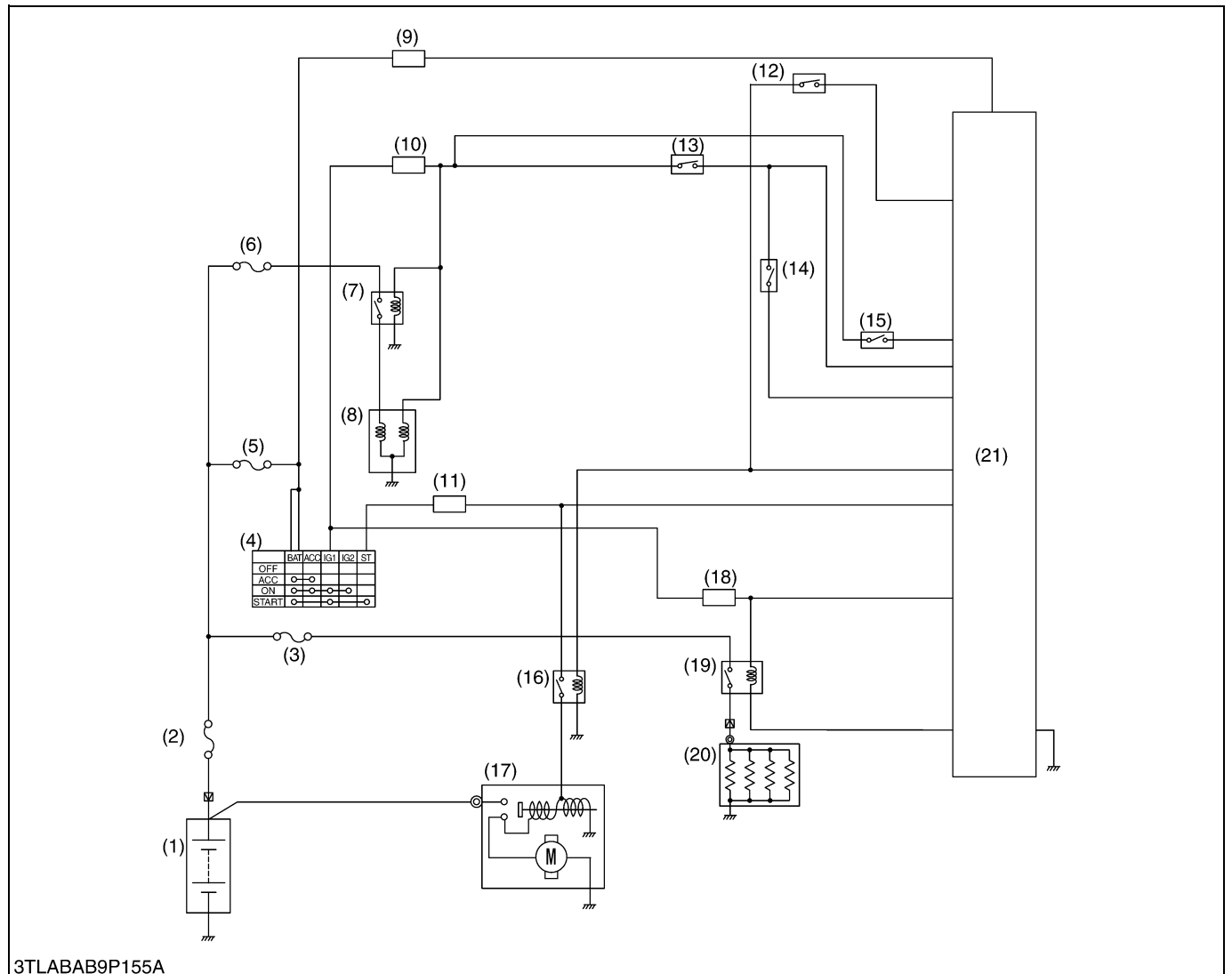
**[4] HST MODEL**

- |                           |                             |                         |  |
|---------------------------|-----------------------------|-------------------------|--|
| (1) Battery               | (7) Key Stop Solenoid Relay | (13) HST Pedal Switch   | (18) Fuse (7.5 A)                                  |
| (2) Slow Blow Fuse (80 A) | (8) Key Stop Solenoid       | (14) Main Clutch Switch | (19) Glow Relay                                    |
| (3) Slow Blow Fuse (50 A) | (9) Fuse (5 A)              | (15) Cruise Switch      | (20) Glow Plug                                     |
| (4) Main Switch           | (10) Fuse (5 A)             | (16) Starter Relay      | (21) Electronic Instrument Panel<br>(IntelliPanel) |
| (5) Slow Blow Fuse (60 A) | (11) Fuse (30 A)            | (17) Starter            |  |
| (6) Slow Blow Fuse (30 A) | (12) PTO Switch             |                         |  |

## 4. CHARGING SYSTEM

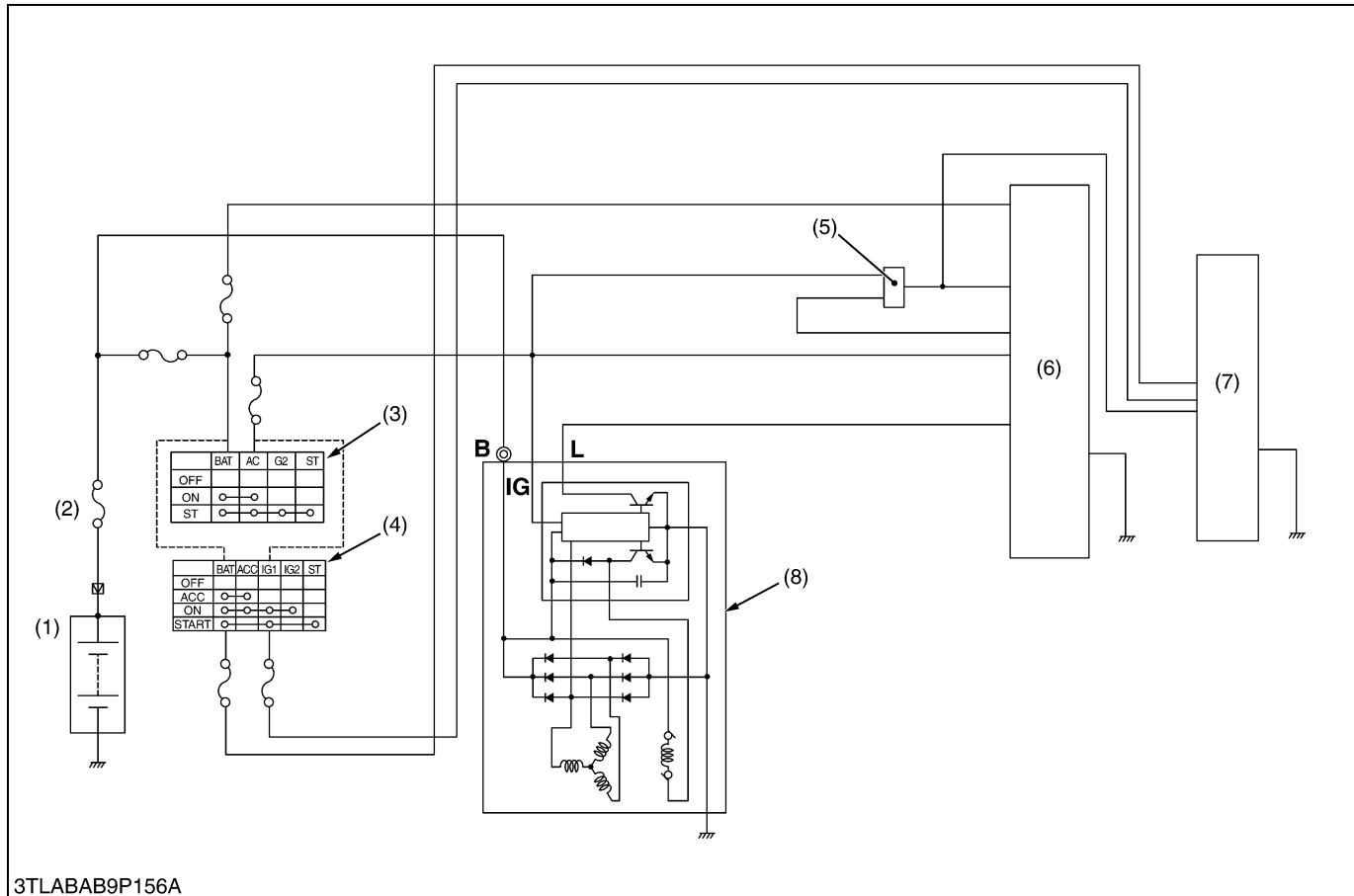

- |   |                              |   |                          |
|---|------------------------------|---|--------------------------|
| (1) Battery                                       | (3) Main Switch (for ROPS)   | (6) Electronic Instrument Panel<br>(IntelliPanel) | (7) ECU (GST Model Only) |
| (2) Slow Blow Fuse<br>(ROPS : 60 A, Cabin : 80 A) | (4) Main Switch (for Cabin)  | (8) Alternator                                    |                          |
|   | (5) Engine Tachometer Sensor |   |                          |

## 5. LIGHTING SYSTEM

### [1] ROPS TYPE

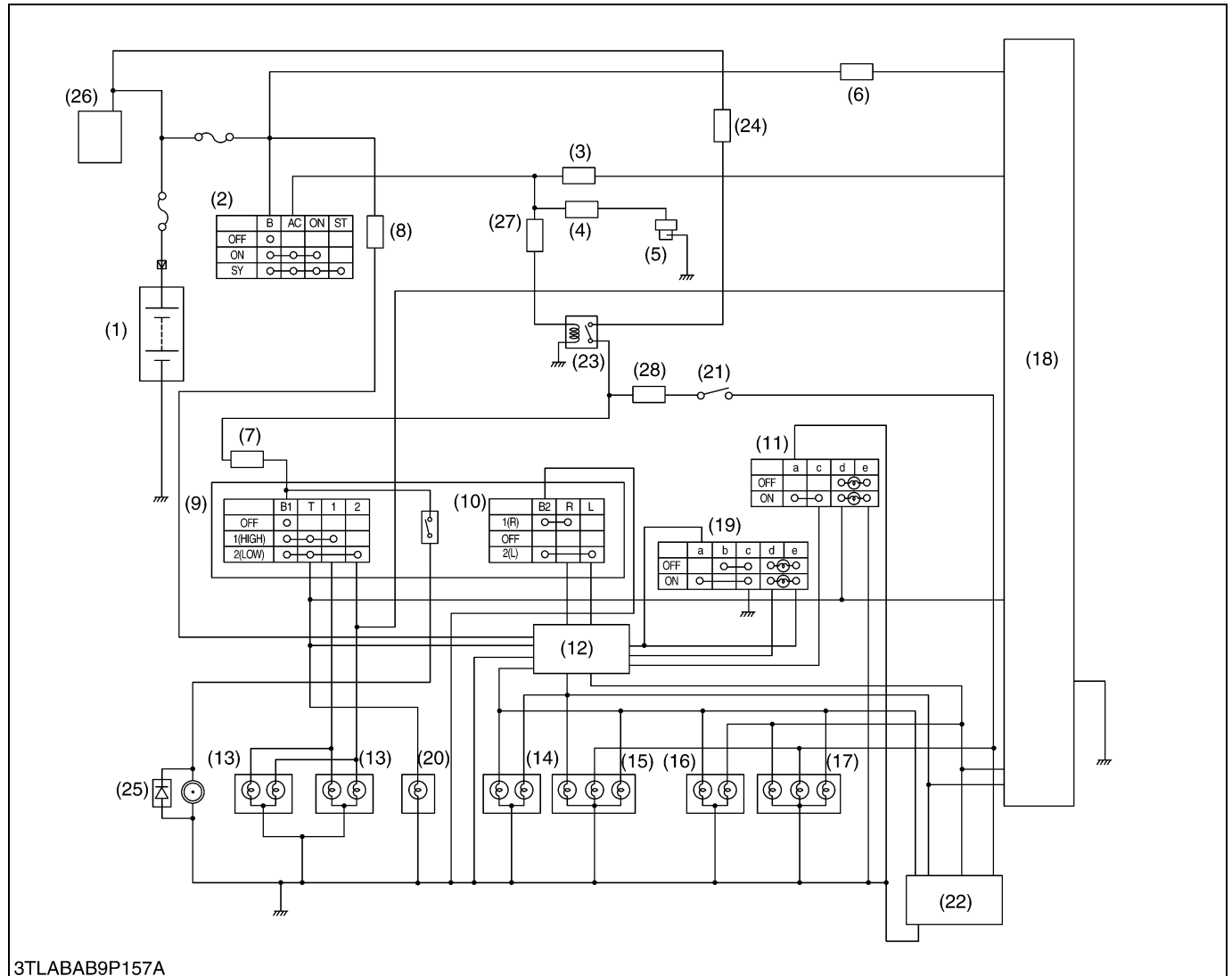

- |                            |                                 |                                  |                     |
|----------------------------|---------------------------------|----------------------------------|---------------------|
| (1) Battery                | (9) Head Light Switch           | (16) Front Combination Lamp, LH  | (22) Trailer Socket |
| (2) Main Switch            | (10) Turn Signal Switch         | (17) Rear Combination Lamp, LH   | (23) Lamp Relay     |
| (3) Fuse (7.5 A)           | (11) Hazard Switch              | (18) Electronic Instrument Panel | (24) Fuse (45 A)    |
| (4) Fuse (7.5 A)           | (12) Flasher Unit               | (IntelliPanel)                   | (25) Horn           |
| (5) Working Light (Option) | (13) Head Light                 | (19) Position Switch             | (26) Alternator     |
| (6) Fuse (5 A)             | (14) Front Combination Lamp, RH | (20) License Plate Lamp          | (27) Fuse (5 A)     |
| (7) Fuse (25 A)            | (15) Rear Combination Lamp, RH  | (21) Brake Lamp Switch           | (28) Fuse (20 A)    |
| (8) Fuse (7.5 A)           |                                 |                                  |                     |

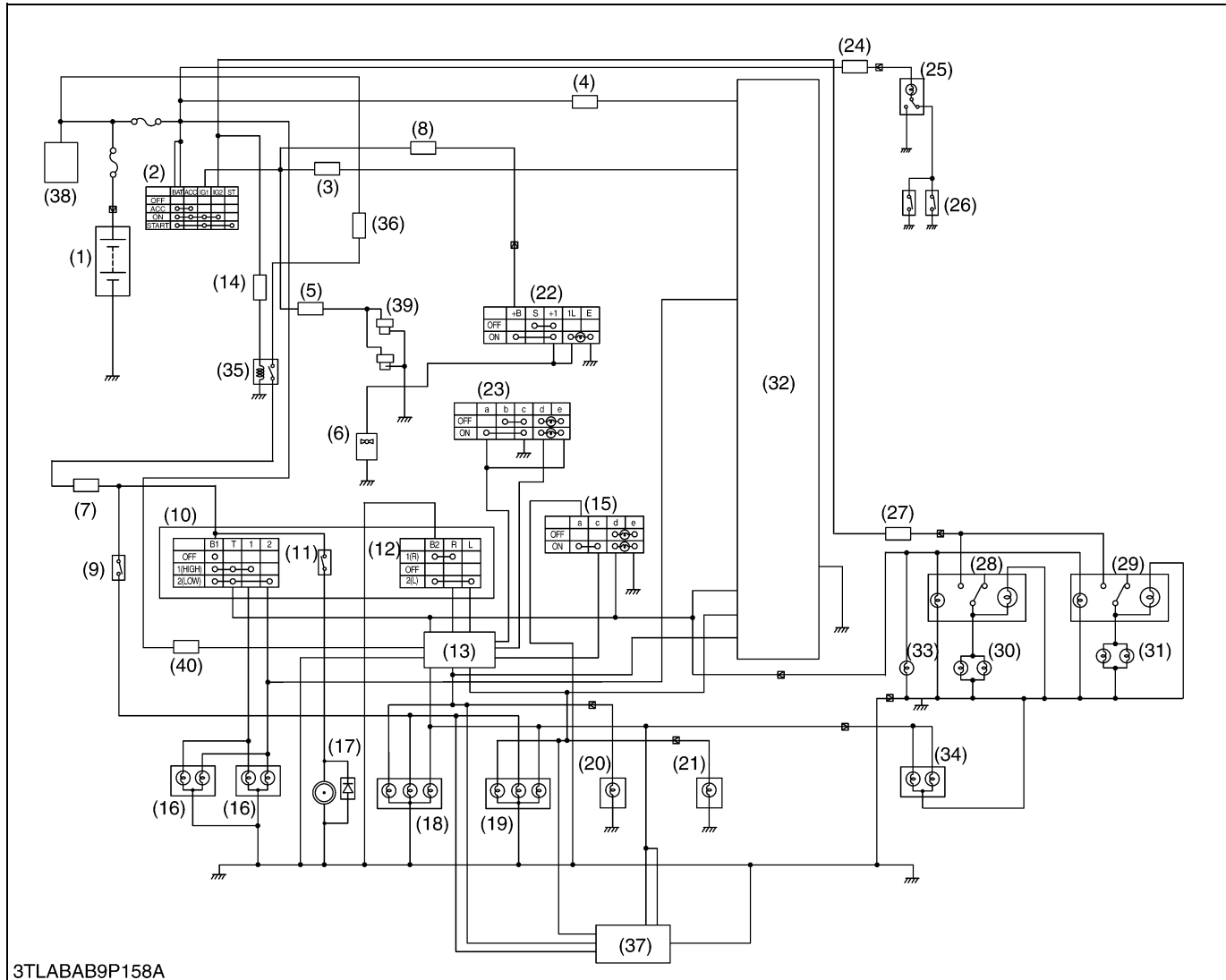
**[2] CABIN TYPE**

3TLBAB9P158A

- |                        |                                |                                  |   |
|------------------------|--------------------------------|----------------------------------|---|
| (1) Battery            | (12) Turn Signal Switch        | (22) Patrol Lamp Switch          | (32) Electronic Instrument Panel (IntelliPanel) |
| (2) Main Switch        | (13) Flasher Unit              | (23) Position Switch             | (33) License Plate Lamp                         |
| (3) Fuse (7.5 A)       | (14) Fuse (5 A)                | (24) Fuse (10 A)                 | (34) Position Light                             |
| (4) Fuse (5 A)         | (15) Hazard Switch             | (25) Room Lamp                   | (35) Lamp Relay                                 |
| (5) Fuse (20 A)        | (16) Head Light                | (26) Door Switch                 | (36) Fuse (45 A)                                |
| (6) Patrol Lamp        | (17) Horn                      | (27) Fuse (15 A)                 | (37) Trailer Socket                             |
| (7) Fuse (20 A)        | (18) Rear Combination Lamp, RH | (28) Working Light Switch, Front | (38) Alternator                                 |
| (8) Fuse (10 A)        | (19) Rear Combination Lamp, LH | (29) Working Light Switch, Rear  | (39) Working Light (Option)                     |
| (9) Brake Lamp Switch  | (20) Turn Signal Light, RH     | (30) Working Light, Front        | (40) Fuse (7.5 A)                               |
| (10) Head Light Switch | (21) Turn Signal Light, LH     | (31) Working Light, Rear         |   |
| (11) Horn Switch       |                                |                                  |   |

# SERVICING

## CONTENTS

1. TROUBLESHOOTING .....	9-S1
2. SERVICING SPECIFICATIONS .....	9-S8
3. TIGHTENING TORQUES .....	9-S9
4. CHECKING, DISASSEMBLING AND SERVICING.....	9-S10
[1] BATTERY.....	9-S10
(1) Checking.....	9-S10
[2] ELECTRONIC INSTRUMENT PANEL (INTELLIPANEL).....	9-S12
(1) Testing, Setting and Adjusting by Electronic Instrument Panel (IntelliPanel).....	9-S12
(2) Checking Electrical Control System.....	9-S20
(3) Checking GST Electric Control System (GST Model Only) .....	9-S27
[3] STARTING SYSTEM .....	9-S33
(1) Checking.....	9-S33
(2) Disassembling and Assembling.....	9-S41
(3) Servicing .....	9-S41
[4] CHARGING SYSTEM.....	9-S44
(1) Checking.....	9-S44
(2) Disassembling and Assembling.....	9-S45
(3) Servicing .....	9-S47
[5] LIGHTING SYSTEM .....	9-S49
(1) Checking.....	9-S49
[6] WARNING LAMPS.....	9-S53
(1) Checking.....	9-S53
[7] MONITOR LAMP .....	9-S54
(1) Checking.....	9-S54
[8] GAUGES.....	9-S56
(1) Checking.....	9-S56



# 1. TROUBLESHOOTING

Symptom	Probable Cause	Solution	Reference Page
<b>All Electrical Equipment Do Not Operate</b>	• Battery discharged or defective	Recharge or replace	G-25
	• Battery positive cable disconnected or improperly connected	Repair or replace	–
	• Battery negative cable disconnected or improperly connected	Repair or replace	–
	• Slow blow fuse blown	Replace	G-36
<b>Fuse Blown Frequently</b>	• Short-circuited	Repair or replace	–

W10143220

## BATTERY

<b>Battery Discharges Too Quickly</b>	• Battery defective	Replace	–
	• Alternator defective	Repair or replace	9-S44
	• IC Regulator defective	Replace	9-S44
	• Wiring harness disconnected or improperly connected (between battery positive terminal and regulator <b>B</b> terminal)	Repair or replace	–
	• Cooling fan belt slipping	Adjust tension	G-23

W10137180

## STARTING SYSTEM

<b>Starter Motor Does Not Operate</b>	• Battery discharged or defective	Recharge or replace	G-25
	• Slow blow fuse blown	Replace	G-36
	• Safety switch improperly adjusted or defective	Repair or replace	9-S35
	• Wiring harness disconnected or improperly connected (between main switch terminal and safety switches, between safety switches and starter motor, between battery positive terminal and starter motor)	Repair or replace	–
	• Starter motor defective	Repair or replace	9-S41
	• Main switch defective	Replace	9-S33
	• Connector <b>A</b> for electronic instrument panel (IntelliPanel) disconnected or improperly connected	Repair or replace	9-S23
	• IntelliPanel defective	Replace	9-S23
<b>Glow Lamp Does Not Light</b>	• Coolant temperature sensor defective	Replace	9-S55
	• Bulb blown	Replace	G-37
	• Main switch defective	Replace	9-S33
	• Circuit in IntelliPanel defective	Replace	–
	• Wiring harness disconnected or improperly connected (between main switch terminal and IntelliPanel, between IntelliPanel and glow relay, between glow relay and ground)	Repair or replace	–
	• IntelliPanel defective	Replace	9-S23

W10137180

**CHARGING SYSTEM**

Symptom	Probable Cause	Solution	Reference Page
<b>Charging Lamp Does Not Light when Main Switch is Turned ON</b>	• Wiring harness disconnected or improperly connected (between main switch terminal and IntelliPanel, between IntelliPanel and alternator)	Repair or replace	–
	• Alternator defective	Repair or replace	9-S44
<b>Charging Lamp Does Not Go Off When Engine is Running</b>	• Wiring harness disconnected or improperly connected (between main switch terminal and alternator, between IntelliPanel and alternator)	Repair or replace	–
	• Alternator defective	Repair or replace	9-S44

W10135800

**LIGHTING SYSTEM**

<b>Head Light Does Not Light</b>	<ul style="list-style-type: none"> <li>• Fuse blown</li> <li>• Bulb blown</li> <li>• Wiring harness disconnected or improperly connected (between main switch terminal and combination switch <b>B1</b> terminal, between combination switch <b>1</b> terminal and head light, between combination switch <b>2</b> terminal and head light)</li> </ul>	Replace Replace Repair or replace	G-36 G-37 –
<b>Hazard Light Does Not Light</b>	<ul style="list-style-type: none"> <li>• Fuse blown</li> <li>• Bulb blown</li> <li>• Wiring harness disconnected or improperly connected</li> <li>• Flasher unit defective</li> <li>• Hazard switch defective</li> </ul>	Replace Replace Repair or replace  Replace Replace	G-36 G-37 –  9-S52 9-S51
<b>Position Light Does Not Light</b>	<ul style="list-style-type: none"> <li>• Fuse blown</li> <li>• Bulb blown</li> <li>• Wiring harness disconnected or improperly connected</li> <li>• Flasher unit defective</li> <li>• Position switch defective</li> </ul>	Replace Replace Repair or replace  Replace Replace	G-36 G-37 –  9-S52 9-S52

W10137180

**EASY CHECKER**

<b>Engine Oil Pressure Lamp Lights Up When Engine Is Running</b>	<ul style="list-style-type: none"> <li>• Engine oil pressure too low</li> <li>• Engine oil insufficient</li> <li>• Engine oil pressure switch defective</li> <li>• Short circuit between engine oil pressure switch lead and chassis</li> <li>• Circuit in panel defective</li> </ul>	Repair engine Replenish Replace Repair  Replace	– G-7, 8 9-S53 –  9-S23
<b>Engine Oil Pressure Lamp Does Not Light When Main Switch Is Turned ON and Engine Is Not Running</b>	<ul style="list-style-type: none"> <li>• Bulb blown</li> <li>• Engine oil pressure switch defective</li> <li>• Wiring harness disconnected or improperly connected (between IntelliPanel and engine oil pressure switch)</li> <li>• Circuit in panel defective</li> </ul>	Replace Replace Repair or replace  Replace	G-37 9-S53 –  9-S23

W10137180

**GAUGES**

Symptom	Probable Cause	Solution	Reference Page
<b>Fuel Gauge Does Not Function</b>	<ul style="list-style-type: none"> <li>Fuel unit (tank unit) defective</li> <li>Wiring harness disconnected or improperly connected (between IntelliPanel and fuel level sensor)</li> </ul>	Replace Repair or replace	9-S56 –
	<ul style="list-style-type: none"> <li>Circuit in IntelliPanel defective</li> </ul>	Replace	9-S23
<b>Coolant Temperature Gauge Does Not Function</b>	<ul style="list-style-type: none"> <li>Coolant temperature sensor defective</li> <li>Wiring harness disconnected or improperly connected (between IntelliPanel and coolant temperature sensor)</li> </ul>	Replace Repair or replace	9-S56 –
	<ul style="list-style-type: none"> <li>Circuit in IntelliPanel defective</li> </ul>	Replace	9-S23

W10137180

**ELECTRONIC INSTRUMENT PANEL (INTELLIPANEL)**

<b>Nothing is Displayed in LCD</b>	<ul style="list-style-type: none"> <li>Battery discharged or defective (Battery voltage is below 7 V)</li> </ul>	Recharge or replace	G-25 9-S10
	<ul style="list-style-type: none"> <li>Slow blow fuse blown</li> </ul>	Replace	–
	<ul style="list-style-type: none"> <li>IntelliPanel connector disconnect</li> </ul>	Connect	9-S23
	<ul style="list-style-type: none"> <li>IntelliPanel defective</li> </ul>	Replace	9-S23
<b>Indication on LCD Does Not Change When Pushing the Display Mode Switch</b>	<ul style="list-style-type: none"> <li>Display mode switch defective</li> </ul>	Replace	9-S26
	<ul style="list-style-type: none"> <li>Wiring harness disconnected</li> </ul>	Repair	–
<b>Traveling Speed is Not Indicating</b>	<ul style="list-style-type: none"> <li>Wiring harness disconnected</li> </ul>	Repair	–
	<ul style="list-style-type: none"> <li>Traveling speed sensor defective</li> </ul>	Replace	9-S25
<b>PTO Speed is Not Indicating</b>	<ul style="list-style-type: none"> <li>Wiring harness disconnected</li> </ul>	Repair	–
	<ul style="list-style-type: none"> <li>Engine tachometer sensor defective</li> </ul>	Replace	9-S26
<b>Fuel Gauge is Indicating Always E</b>	<ul style="list-style-type: none"> <li>Wiring harness (GND) disconnected</li> </ul>	Repair or replace	–
	<ul style="list-style-type: none"> <li>Fuel unit defective</li> </ul>		9-S56
<b>Fuel Gauge is Indicating Always F</b>	<ul style="list-style-type: none"> <li>Wiring harness short-circuited</li> </ul>	Repair or replace	–
	<ul style="list-style-type: none"> <li>Fuel unit defective</li> </ul>	Replace	9-S56
<b>Position of Range Gear Shift Lever Is Not Indicated (for HST Model)</b>	<ul style="list-style-type: none"> <li>Wiring harness disconnected</li> </ul>	Repair or replace	–
	<ul style="list-style-type: none"> <li>Range gear shift lever sensor defective</li> </ul>	Replace	9-S24

W10233580

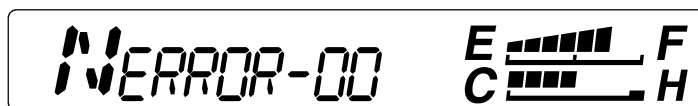

## ■ Error Display



→ Error message is displayed here

Display on LCD Screen	Trouble Item (Affected Model)	Probable Cause	Solution	Reference Page
	IntelliPanel memory device has failed (All model)	<ul style="list-style-type: none"> <li>IntelliPanel memory device failure</li> </ul>	<ul style="list-style-type: none"> <li>Replace IntelliPanel</li> </ul>	9-S23
 <b>Selected Travel Speed Is Not Displayed on LCD</b>	HST range gear shift lever sensor failure (HST model)	<ul style="list-style-type: none"> <li>Lever sensor output terminal is out of adjustment</li> <li>Lever sensor wire connector is broken or short-circuited</li> <li>Lever sensor defective</li> </ul> <p><b>NOTE:</b>  <b>ERROR-10 : is not automatically displayed in the LCD, but it is memorized in the IntelliPanel as error information</b></p>	<ul style="list-style-type: none"> <li>Check lever sensor wire connector</li> <li>Check sensor voltage by Test mode (<b>Mode A</b>)</li> <li>Check sensor voltage by connector</li> <li>Check sensor resistance</li> <li>Replace lever sensor</li> </ul>	9-S24 9-S13 9-S24 9-S26 9-S26
	Wrong setting of IntelliPanel (Manual Transmission and HST model)	<ul style="list-style-type: none"> <li>GST specified IntelliPanel installed wrong on HST or Manual transmission model</li> </ul>	<ul style="list-style-type: none"> <li>Input appropriate transmission model by Transmission model Input Mode (<b>Mode I</b>)</li> </ul>	9-S19
	Communication error between ECU and IntelliPanel (GST model)	<ul style="list-style-type: none"> <li>Fuse blown out</li> <li>Communication line between ECU and IntelliPanel is broken or short-circuited</li> <li>No signals from ECU for longer than 5 seconds (error cleared if signal sent and received later)</li> <li>ECU defective</li> </ul>	<ul style="list-style-type: none"> <li>Check fuse</li> <li>Check ECU connector</li> <li>Check communication line between ECU and IntelliPanel at ECU connector</li> <li>Replace ECU</li> </ul>	9-S27 9-S27 9-S31 9-S28
	ECU memory device has failed (GST model)	<ul style="list-style-type: none"> <li>ECU memory device failure</li> </ul>	<ul style="list-style-type: none"> <li>Replace ECU</li> </ul>	9-S28

W1013580

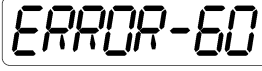
Display on LCD Screen	Trouble Item (Affected Model)	Probable Cause	Solution	Reference Page
	Input voltage to lever sensor from ECU is failed (GST model)	<ul style="list-style-type: none"> <li>Lever sensor input voltage drop below 2.6 V for 0.1 second or more</li> <li>Ground wire of lever sensor short-circuited</li> </ul>	<ul style="list-style-type: none"> <li>Check ground wire</li> <li>Check input voltage at ECU connector</li> <li>Check sensor connector</li> </ul>	9-S27 9-S29 –
	GST lever sensor is failed (GST model)	<ul style="list-style-type: none"> <li>Lever sensor output terminal is out of adjustment</li> <li>Lever sensor output wire terminal broken or short-circuited</li> <li>Input line broken</li> <li>Lever sensor defective</li> </ul>	<ul style="list-style-type: none"> <li>It is possible to run at its selected speed position until engine is stopped.</li> <li>Check sensor connector</li> <li>Check sensor voltage by Test mode (Mode A)</li> <li>Check lever sensor wire connector (voltage) or check sensor resistance</li> <li>Replace lever sensor</li> </ul>	– – 9-S13 9-S29, S31 9-M15
	Proportional reducing valve failure (GST model)	<ul style="list-style-type: none"> <li>Output voltage of proportional reducing valve terminal or return current is out of specification</li> <li>Valve wire broken or short-circuited</li> <li>Proportional reducing valve defective</li> </ul>	<ul style="list-style-type: none"> <li>Check connector of proportional reducing valve</li> <li>Check proportional reducing valve resistance at valve or ECU connector</li> <li>Check grounding wire</li> <li>Connect emergency connector and move</li> </ul>	– 9-S30, S32 9-S27 9-M17

W1053954

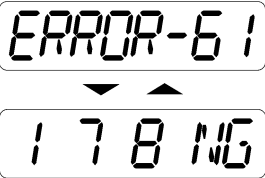
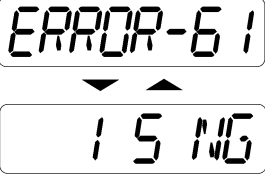
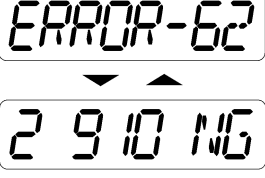
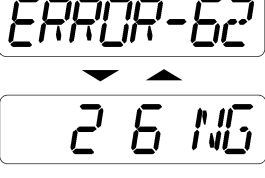
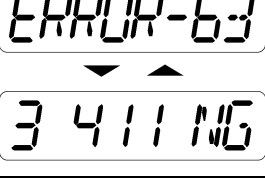
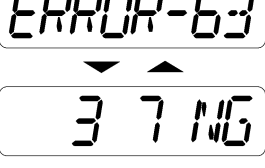
Display on LCD Screen	Trouble Item (Affected Model)	Probable Cause	Solution	Reference Page
	Solenoid 1 failure (At forward or neutral) (GST model)	<ul style="list-style-type: none"> <li>• Solenoid output terminal's voltage is out of specification</li> <li>• Solenoid broken or short-circuited</li> <li>• Wiring harness broken or short-circuited</li> <li>• Grounding plate of solenoid is poor contact with chassis</li> </ul>	<ul style="list-style-type: none"> <li>• Able to travel at speeds other than 1, 7 and 8 (Forward) or 1 and 5 (Reverse)</li> <li>• Check the wiring connector of solenoid</li> <li>• Check a resistance between solenoid and GND</li> <li>• Replace GST valve</li> </ul>	—
	Solenoid 1 failure (At reverse) (GST model)			9-S30, S32 3-S79
	Solenoid 2 failure (At forward or neutral) (GST model)			—
	Solenoid 2 failure (At reverse) (GST model)			9-S30, S32 9-S79
	Solenoid 3 failure (At forward or neutral) (GST model)			—
	Solenoid 3 failure (At reverse) (GST model)			9-S30, S32 3-S79

W1011845

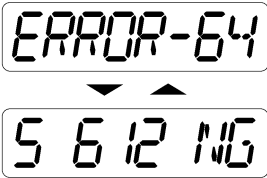
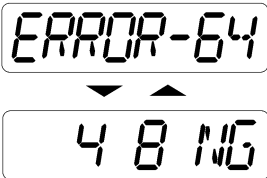
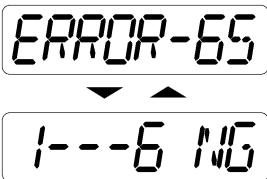
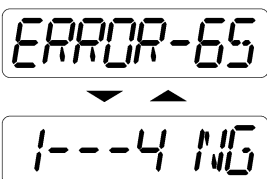
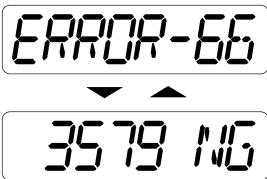

Display on LCD Screen	Trouble Item (Affected Model)	Probable Cause	Solution	Reference Page
	Solenoid 4 failure (At forward or neutral) (GST model)	<ul style="list-style-type: none"> <li>• Solenoid output terminal's voltage is out of specification</li> <li>• Solenoid broken or short-circuited</li> <li>• Wiring harness broken or short-circuited</li> <li>• Grounding plate of solenoid is poor contact with chassis</li> </ul>	<ul style="list-style-type: none"> <li>• Able to travel at speeds other than 5, 6 and 12 (Forward) or 4 and 8 (Reverse)</li> <li>• Check the wiring connector of solenoid</li> <li>• Check a resistance between solenoid and GND</li> <li>• Replace GST valve</li> </ul>	–
	Solenoid 4 failure (At reverse) (GST model)			–
	Solenoid 6 (Main range gear shift) failure (At forward or neutral) (GST model)			–
	Solenoid 6 (Main range gear shift) failure (At reverse) (GST model)			–
	Solenoid 5 (Sub-range gear shift) failure (GST model)			–
			<ul style="list-style-type: none"> <li>• Able to travel at speeds other than 1 to 6 (Forward) or 1 to 4 (Reverse)</li> <li>• Check the wiring connector of solenoid</li> <li>• Check a resistance between solenoid and GND</li> <li>• Replace GST valve</li> </ul>	9-S30, S32 3-S79
			<ul style="list-style-type: none"> <li>• Able to travel at speeds other than 3, 5, 7 and 9 (Forward)</li> <li>• Check the wiring connector of solenoid</li> <li>• Check a resistance between solenoid and GND</li> <li>• Replace GST valve</li> </ul>	9-S30, S32 3-S79

W1024766

## 2. SERVICING SPECIFICATIONS

Item		Factory Specification	Allowable Limit
Starter	Commutator	O.D. 30.0 mm 1.181 in.	29.0 mm 1.142 in.
	Mica	Under Cut 0.50 to 0.80 mm 0.0197 to 0.0315 in.	0.20 mm 0.0079 in.
	Brush	Length 15.0 mm 0.591 in.	11.0 mm 0.433 in.
	Brush Holder and Holder Support	Resistance Infinity	–
Glow Plug	Resistance	Approx. 0.9 $\Omega$	–
Fuel Level Sensor	Float at Upper-most Position	Resistance 1.0 to 5.0 $\Omega$	–
	Float at Lower-most Position	Resistance 103 to 117 $\Omega$	–
Coolant Temperature Sensor	at 130 °C (266 °F)	Resistance Approx. 12.2 $\Omega$	–
	at 105 °C (221 °F)	Resistance Approx. 23.6 $\Omega$	–
	at 80 °C (176 °F)	Resistance Approx. 51.9 $\Omega$	–
	at 50 °C (122 °F)	Resistance Approx. 153.9 $\Omega$	–
Alternator	No-load voltage	More than 14 V	–
	Stator	Resistance Less than 1.0 $\Omega$	–
	Rotor	Resistance 2.9 $\Omega$	–
	Slip Ring	O.D. 14.4 mm 0.567 in.	12.8 mm 0.504 in.
	Brush	Length 10.5 mm 0.413 in.	8.4 mm 0.331 in.
GST Proportional Reducint Valve	Resistance	Approx. 8 to 9 $\Omega$	–
Shift Solenoid Valve	Resistance	Approx. 11 to 15 $\Omega$	–

W10138740

### 3. TIGHTENING TORQUES

Tightening torques of screws, bolts and nuts on the table below are especially specified.  
(For general use screws, bolts and nuts : See page G-10.)

Item	N·m	kgf·m	ft-lbs
Alternator pulley nut	58.3 to 78.9	5.95 to 8.05	43.0 to 58.2
Starter terminal nut	5.9 to 11.8	0.6 to 1.2	4.3 to 8.7

W10127360

## 4. CHECKING, DISASSEMBLING AND SERVICING

### CAUTION

- To avoid accidental short circuit, be sure to attach the positive cable to the positive terminal before the negative cable is attached to the negative terminal.
- Never remove the battery cap while the engine is running.
- Keep electrolyte away from eyes, hands and clothes. If you are splattered with it, wash it away completely with water immediately.
- Keep open sparks and flames away from the battery at all times. Hydrogen gas mixed with oxygen becomes very explosive.

### ■ IMPORTANT

- If the machine is to be operated for a short time without battery (using a slave battery for starting), use additional current (lights) while engine is running and insulate terminal of battery. If this advice is disregarded, damage to alternator and regulator may result.

## [1] BATTERY

### (1) Checking

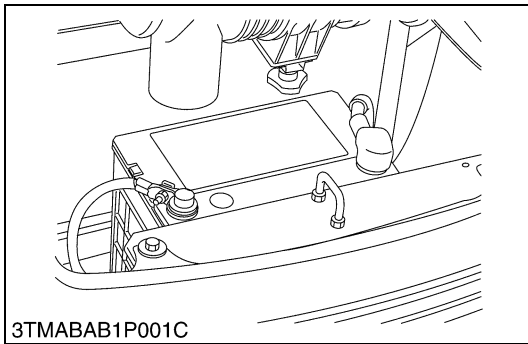

#### Battery Voltage

1. Stop the engine and turn the main switch off.
2. Connect the COM (–) lead of the voltmeter to the battery's negative terminal post and the (+) lead to the positive terminal post, and measure the battery voltage.
3. If the battery voltage is less than the factory specification, check the battery specific gravity and recharge the battery.

Battery voltage	Reference value	More than 12 V
-----------------	-----------------	----------------

W10125620

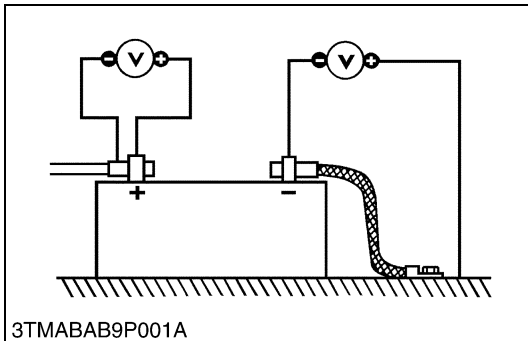

#### Battery Terminal Connection

1. Turn the main switch on, and turn on the head light.
2. Measure the voltage across the battery's positive terminal post and the cable terminal, and the voltage across the battery's negative terminal post and the chassis.
3. If the measurement exceeds the factory specification, clean the battery terminal posts and cable clamps, and tighten them firmly.

Potential difference	Reference value	Less than 0.1 V
----------------------	-----------------	-----------------

W10126630

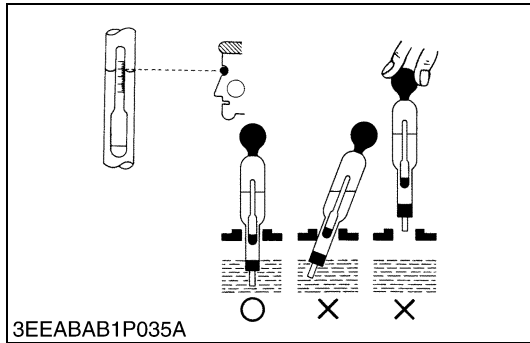
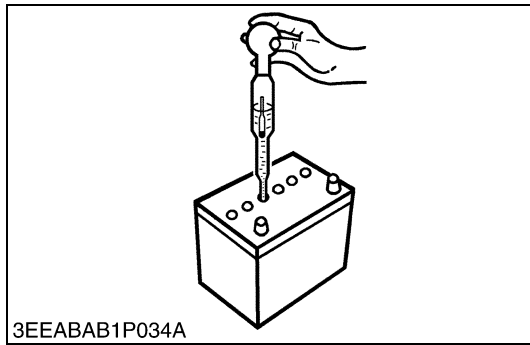

### Battery Specific Gravity

1. Check the specific gravity of the electrolyte in each cell with a hydrometer.
2. When the electrolyte temperature differs from that at which the hydrometer was calibrated, correct the specific gravity reading following the formula mentioned in (Reference).
3. If the specific gravity is less than 1.215 (after it is corrected for temperature), charge or replace the battery.
4. If the specific gravity differs between any two cells by more than 0.05, replace the battery.

#### NOTE

- **HOLD the hydrometer tube vertical without removing it from the electrolyte.**
- **Do not suck too much electrolyte into the tube.**
- **Allow the float to move freely and hold the hydrometer at eye level.**
- **The hydrometer reading must be taken at the highest electrolyte level.**

#### (Reference)

- Specific gravity slightly varies with temperature. To be exact, the specific gravity decreases by 0.0007 with an increase of 1 °C (0.0004 with an increase of 1 °F) in temperature, and increases by 0.0007 with a decreases of 1 °C (0.0004 with a decrease of 1 °F).

Therefore, using 20 °C (68 °F) as a reference, the specific gravity reading must be corrected by the following formula :

- Specific gravity at 20 °C = Measured value + 0.0007 × (electrolyte temperature : 20 °C)
- Specific gravity at 68 °F = Measured value + 0.0004 × (electrolyte temperature : 68 °C)

Specific Gravity	State of Charge
1.260 Sp. Gr.	100 % Charged
1.230 Sp. Gr.	75 % Charged
1.200 Sp. Gr.	50 % Charged
1.170 Sp. Gr.	25 % Charged
1.140 Sp. Gr.	Very Little Useful Capacity
1.110 Sp. Gr.	Discharged

At an electrolyte temperature of 20 °C (68 °F)

W10127630

## [2] ELECTRONIC INSTRUMENT PANEL (INTELLIPANEL)

### (1) Testing, Setting and Adjusting by Electronic Instrument Panel (IntelliPanel)

The following settings, adjustments and testing can be done by using the IntelliPanel.

- Testing : Check a voltage of various sensor or rotation of engine.
- Setting or Adjusting : Input the various data to IntelliPanel or ECU.
- Error Information : Confirm or clear the error information.

#### CAUTION

- To perform the testing of the IntelliPanel the operator must be seated on the tractor.

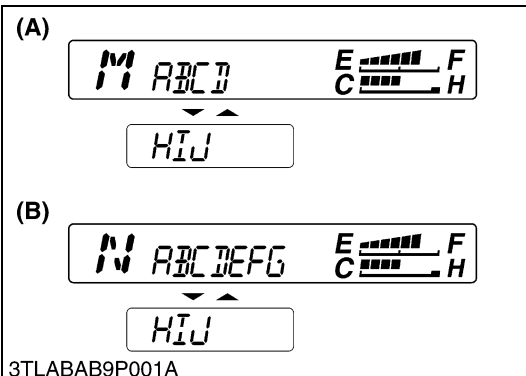

#### ■ Mode Selection

Select a corresponded mode by the following procedure, and do the test, the adjustment, the setting, and the confirmation respectively.

1. While holding down both the display mode switch (2) and the travel speed switch (3) at once, turn the main switch to **ON** or **START** position.
2. Mode selection display is indicated on the LCD.
3. Press the display mode switch (2) and the flashing part moves.
4. Hold down the display mode switch (2) for more than 2 seconds, and the buzzer rings and flashing symbol is selected.

#### ■ NOTE

- To save entire and review the conditions, usually hold down the Display Mode switch (2) until the buzzer rings.
- When a setting has been saved or an adjustment mode in any mode, be sure to turn off the main switch to end the procedure.

- (1) Liquid Crystal Display (LCD)  
 (2) Display Mode Switch  
 (3) Travel Speed Switch

- (A) Mode Selection Display for HST and Manual Transmission Model  
 (B) Mode Selection Display for GST Model

W1010725

Symbol	Mode	Necessary Situation
A	Test Mode	<ul style="list-style-type: none"> <li>• When the checking of sensor voltage or engine revolution is required.</li> </ul>
B	Traveling Speed Coefficient Input Mode	<ul style="list-style-type: none"> <li>• When the IntelliPanel is replaced or changed.</li> <li>• When the tire size is changed.</li> </ul>
C	PTO Coefficient Number Input Mode	<ul style="list-style-type: none"> <li>• When the IntelliPanel is replaced or changed.</li> </ul>
D	Error Information Reset Mode	<ul style="list-style-type: none"> <li>• When deleting the error information.</li> </ul>
E	GST Lever Sensor Fine-adjustment Mode	<ul style="list-style-type: none"> <li>• When the GST lever sensor is replaced or changed.</li> <li>• When the ECU is replaced or changed.</li> </ul>
F	GST Valve Fine-adjustment Mode	<ul style="list-style-type: none"> <li>• When the GST valve is replaced or changed.</li> <li>• When the ECU is replaced or changed.</li> </ul>
G	GST Shift Shock Fine-adjustment Mode	<ul style="list-style-type: none"> <li>• When the shifting shock is not comfortable.</li> </ul>
H	Error Information Display Mode	<ul style="list-style-type: none"> <li>• When checking the error history.</li> </ul>
I	Transmission Model Input Mode	<ul style="list-style-type: none"> <li>• When the IntelliPanel is replaced or changed.</li> <li>• When the HST range shift lever sensor is replaced or changed.</li> </ul>
J	Speed Unit Input Mode	<ul style="list-style-type: none"> <li>• When the IntelliPanel is replaced or changed.</li> </ul>

W1083952



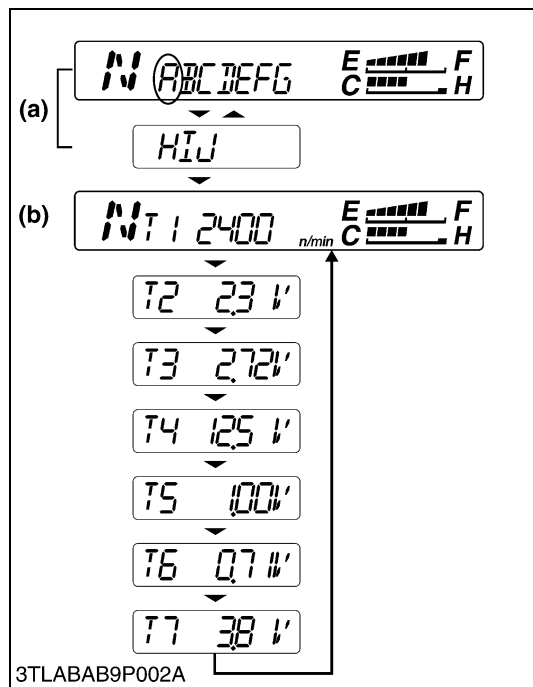

■ Test Mode (Mode “A”)

1. Select the mode “A” (See page 9-S12 “Mode Selection”).
2. “T1” is displayed (b).
3. Each time the display mode switch is pressed, the symbol changes from “T1” to “T7” with the buzzer sound.
4. Turn off the main switch to end the mode “A”.

(a) Mode Selection Display

(b) Testing Display

W1011155

Symbol	Contents	Condition	Value (unit)	Availability*		
				M	G	H
T1	Engine revolution	Idling to Max.	700 to Max. (min <sup>-1</sup> (rpm))	☆	☆	☆
T2	Coolant temperature sensor voltage	-20 → 60 → 100 °C (-4 → 140 → 212 °F)	4.76 to 4.81 → 2.80 to 3.0 → 0.77 to 0.83 (V)	☆	☆	☆
T3	Fuel sensor voltage	F to E	Below 0.31 to above 3.24 (V)	☆	☆	☆
T4	Battery Voltage		More than 12 (V)	☆	☆	☆
T5	HST range gear shift lever sensor voltage	L → N → M → N → H	3.55 to 4.45 → 2.95 to 3.85 → 2.05 to 2.95 → 1.15 to 2.05 → 0.55 to 1.45 (V)			☆
T6	GST shift lever sensor voltage	N → 8 <sup>th</sup> → 12 <sup>th</sup>	0.41 to 1.01 → 2.77 to 3.37 → 3.91 to 4.51 (V)		☆	
T7	Oil temperature sensor voltage	-20 → 60 → 100 °C (-4 → 140 → 212 °F)	4.46 to 4.57 → 1.71 to 1.91 → 0.34 to 0.38 (V)		☆	

\*M : Manual Transmission Model

G : GST Model

H : HST Model

W1012736

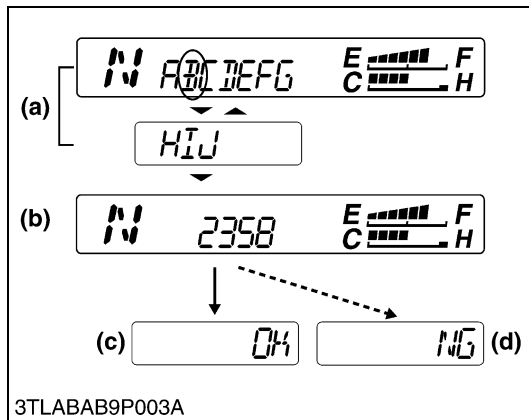

### ■ Traveling Speed Coefficient Input Mode (Mode “B”) (Input the 4 digit tire code for correct travel speed to the IntelliPanel memory panel)

#### ■ NOTE

- When the tire size is changed or IntelliPanel is replaced, this operation is required.

1. Select the mode “B” (See page 9-S12 “Mode Selection”).
2. “0000” or the existing 4-digit numerical setting is displayed (b).
3. To change the code, select the appropriate code, referring to the tractor model and tire size.

#### (Numeric modification)

- Each time the display mode switch is pressed, the flashing number shifts. Press the travel speed switch to change the number.
4. Hold down the display mode switch for more than 2 seconds to preserve the code in the panel’s memory.
  5. “OK” is displayed (c) : The code has been input correctly.  
“NG” is displayed (d) : Incorrect input. Repeat the procedure.
  6. Turn off the main switch to end the mode “B”.

Tractor Model	Rear wheel tire size	Operation Coefficient
L3130 L3430	11.2 – 24	<b>2239</b>
	12.4 – 24	<b>2330</b>
	355/80 – D20	<b>2178</b>
L3830 L4630	12.4 – 24	<b>2321</b>
	13.6 – 24	<b>2453</b>
	13.6 – 26	<b>2558</b>
	355/80 – D20	<b>2178</b>
	475/65 – D20	<b>2271</b>
L5030	13.6 – 28	<b>2463</b>
	475/65 – D20	<b>2099</b>

(a) Mode Selection Display  
(b) Input Display

(c) Correct Preserving Display  
(d) Incorrect Preserving Display

W1012066

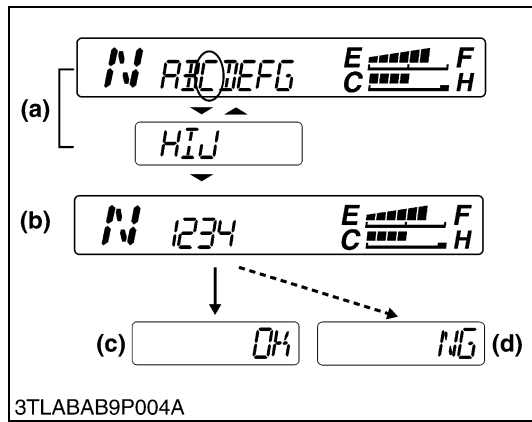

■ **PTO Coefficient Number Input Mode (Mode “C”)**

(Input the numeric code number for PTO speed into the IntelliPanel)

■ **NOTE**

- **When the IntelliPanel is replaced, this operation is required.**
1. Select the mode “C” (See page 9-S12 “Mode Selection”).
  2. “1234” is displayed (b). The existing numerical code setting will flash.
  3. To change the setting, select an appropriate input coefficient number, referring to the tractor model  
**(Numeric modification)**  
- Each time display mode switch is pressed, the flashing number shifts.
  4. Hold down the display mode switch for more than 2 seconds with the correct code number flashing. (Preserve the data to IntelliPanel’s memory)
  5. “OK” is displayed (c) : The code number has been input correctly.  
“NG” is displayed (d) : The code number has not been input correctly. Repeat the procedure.
  6. Turn off the main switch to end the mode “C”.

Operation Coefficient No.	Tractor model	Transmission model
1	L3130, L3430, L3830, L4630, L5030	Manual transmission GST
2	L3130, L3430, L3830, L4630	HST
3	–	–
4	L5030	HST

(a) Mode Selection Display  
(b) Input Display

(c) Correct Preserving Display  
(d) Incorrect Preserving Display

W1013003

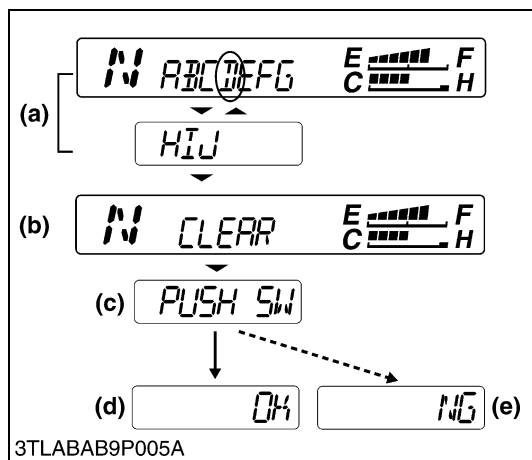

■ **Error Information Reset Mode (Mode “D”)**

(Delete the error information from the IntelliPanel)

1. Select the mode “D” (See page 9-S12 “Mode Selection”).
2. “CLEAR” is displayed (b) and “PUSH SW” is displayed (c) for 2 seconds.
3. Hold down the display mode switch for more than 2 seconds, and the error information is deleted.
4. “OK” is displayed (d) : The IntelliPanel memory has been reset correctly.  
“NG” is displayed (e) : The resetting process has failed. Repeat the procedure.
5. Turn off the main switch to end the mode “D”.

(a) Mode Selection Display  
(b) Information Display  
(c) Resetting Display

(d) Correct Operation Display  
(e) Incorrect Operation Display

W1013628

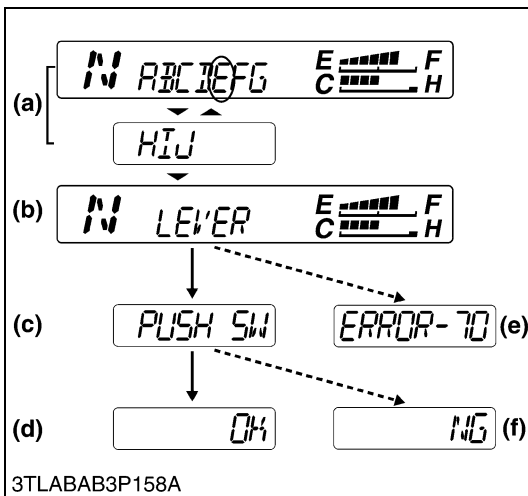

### ■ GST Lever Sensor Fine-adjustment (Mode “E”) (Setting the GST lever’s neutral position with its sensor)

#### ■ IMPORTANT

- As for this fine-adjustment, be sure to set it correctly because the set state becomes the standard of the control thereafter.

#### ■ NOTE

- When the GST lever sensor, the ECU or the IntelliPanel is replaced, this adjustment is required.

1. Set the GST shift lever to **Neutral** position.
2. Select mode “E” (See page 9-S12 “Mode Selection”).
3. “LEVER” is displayed (b) and “PUSH SW” is displayed (c) for five seconds.
4. Hold down the display mode switch for more than 2 seconds. (This preserve the adjusted value to the ECU.)
5. “OK” is displayed (d) on LCD screen to tell that preserving to ECU has been made correctly. Turn off the main switch to end the mode.

If “NG” is displayed (f), it means the preserving has not been made correctly (4). Turn off the main switch and repeat the procedure.

6. If “LEVER” is displayed (b) first and then “ERROR-70” shows up (e), it means the lever sensor voltage is out of specification.

In this case;

- Check to see that GST lever is at the **Neutral** position.
- Check the lever sensor voltage in the Test Mode (Mode “A”) (see page 9-S13). If out of specification, replace the sensor itself.

7. Turn off the main switch to end the mode “E”.

- (1) Liquid Crystal Display (LCD)
- (2) Display Mode Switch
- (3) Travel Speed Switch

- (a) Mode Selection Display
- (b) Information Display
- (c) Adjusting Display
- (d) Correct Preserving Display
- (e) Error Display
- (f) Incorrect Preserving Display

W1018758

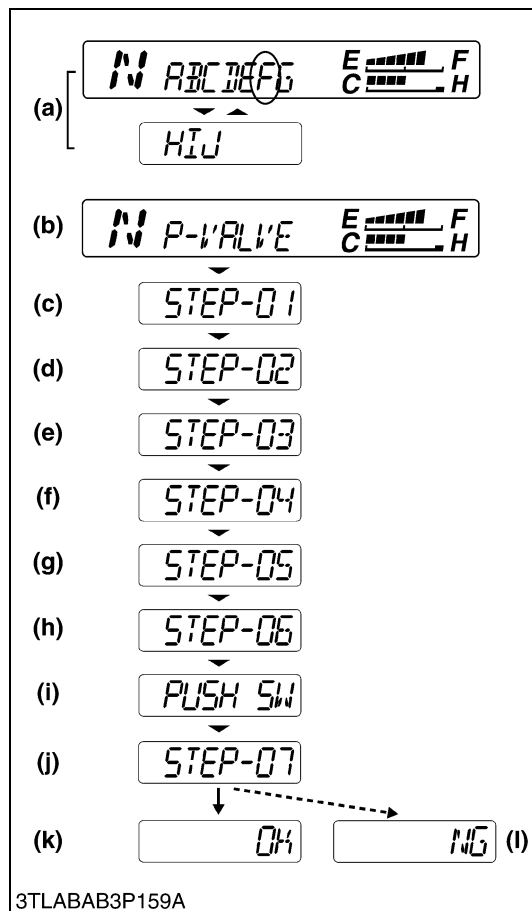

### ■ GST Valve Fine-adjustment Mode (Mode “F”) (Setting the function of proportional reducing valve)

#### ■ NOTE

- When the ECU or GST valve is replaced, this adjustment is required.

1. While holding down the both switches at once, start the engine.
2. Select mode “F” (See page 9-S12 “Mode Selection”).
3. “P-VALVE” is displayed (b) and STEP-01 (c) is displayed the 3 seconds after.

#### ■ NOTE

- To make this adjustment, follow these steps in the exact order described. (Otherwise the switch does not work to go to next step. At “STEP-01” and “STEP-03”, however, the next step can be moved without their settings.)

- Push the display mode switch to move to the next step.
4. **STEP-01 (c)** : Release parking brake.
  5. **STEP-02 (d)** : Set the engine speed at 1000 to 1400 min<sup>-1</sup> (rpm).
  6. **STEP-03 (e)** : Set front tires straight ahead.
  7. **STEP-04 (f)** : Operate the speed selection lever (GST lever) as follows ; disengaged the clutch, select “forward” with the shuttle lever, and shift the GST lever from 1 through 12 several times. Set the GST lever at the positions other than neutral.
  8. **STEP-05 (g)** : Set the GST lever to **Neutral** position.
  9. **STEP-06 (h)** : Set shuttle lever to forward and engage clutch.
  10. **PUSH SW (i)** : Push the display mode switch for more than 3 seconds.
  11. **STEP-07 (j)** : To perform this function the operator must be seated on the tractor.

After a short delay the tractor will begin to move slowly. And then, after it moves a little, the tractor stops automatically. (Fine-adjustment is being executed.)

12. **OK** is displayed (k) : The setting has been preserved correctly to the ECU.

**NG** is displayed (l) : The setting has not been correctly saved in the ECU. Repeat the entire procedure.

- |                            |                                  |
|----------------------------|----------------------------------|
| (a) Mode Selection Display | (g) Setting Display-5            |
| (b) Information Display    | (h) Setting Display-6            |
| (c) Setting Display-1      | (i) Adjusting Display            |
| (d) Setting Display-2      | (j) Setting Display-7            |
| (e) Setting Display-3      | (k) Correct Preserving Display   |
| (f) Setting Display-4      | (l) Incorrect Preserving Display |

W1020355

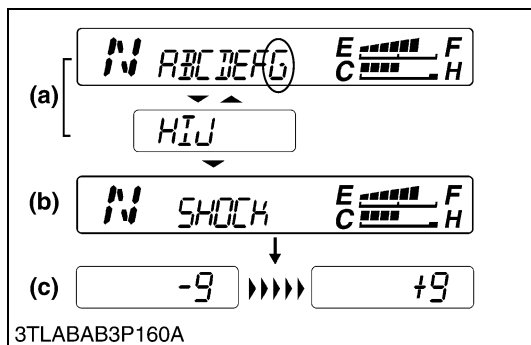

### ■ GST Shift Shock Fine-adjustment Mode (Mode "G") (Adjusting the clutch engaging interval)

#### ■ NOTE

- When the sense of shifting shock is not suitable, shifting shock can be changed by this adjustment.

1. While holding down the both switches at once, start the engine.
2. Select mode "G" (See page 9-S12 "Mode Selection").
3. "SHOCK" is displayed (b) first and then the numerical code setting is displayed (c).

The number "-9" through "+9" can be displayed. This has been factory-adjusted to "0".

4. Setting;
  - For lighter shifting shock;  
Press the travel speed switch to reduce the number.
  - For higher shifting shock;  
Press the display mode switch to increase the number.
5. Move the tractor to confirm the shifting shock.
6. Turn off the key. Then setting will be put in memory.

#### ■ NOTE

- If the shift shock has been adjusted but no remarkable effect can be felt, keep the setting at "0".

(a) Mode Selection Display

(c) Setting Number Display

(b) Information Display

W1020862

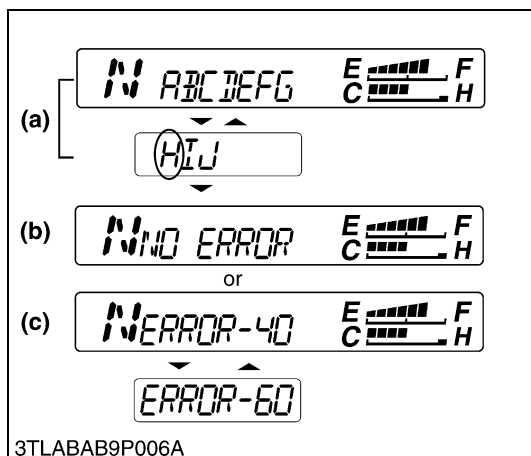

### ■ Error Information Display Mode (Mode "H") (Confirming or Reviewing the Error Information)

1. Select mode "H" (See page 9-S12 "Mode Selection").
2. If there is not error information in memory, "NO ERROR" is displayed (b).

If there is error information in memory, its information is displayed (c).

3. If there are two or more error information readouts, presses the display mode switch and the stored information can be reviewed one by one.
4. Turn off the main switch to end the mode "H".

#### ■ NOTE

- Even if a problem has been corrected or repaired, the information is displayed until it is deleted.
- Refer to "Error Information Reset Mode (Mode "D") for deleting the error information.

(a) Mode Selection Display

(b) Information Display

W1014747



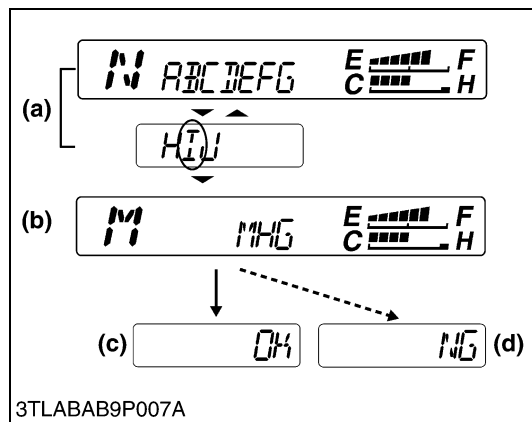

### ■ Transmission Model Input Mode (Mode “I”) (Input the transmission model into IntelliPanel)

#### ■ NOTE

- When the IntelliPanel is replaced, this operation is required.
- On the HST models, the range gear shift lever sensor must be adjusted at the same time.

1. Select mode “I” (See page 9-S12 “Mode Selection”).
2. “MHG” is displayed (b), and the existing symbol setting is flashing.

#### (Reference)

- “M” : Manual Transmission Model
- “H” : HST Model
- “G” : GST Model

3. To change the setting, select either “G” or “M”, and input to the IntelliPanel. Each time display mode switch is pressed, the flashing symbol shifts. And then, hold down switch for more than 2 seconds with the symbol flashing.
4. “OK” is displayed (c) : The tractor model has been input correctly.  
If “NG” is displayed (d) : The tractor model has not been input correctly. Repeat the procedure.
5. Turn off the main switch to end the mode “I”.

(a) Mode Selection Display

(b) Input Display

(c) Correct Preserving Display

(d) Incorrect Preserving Display

W1014885

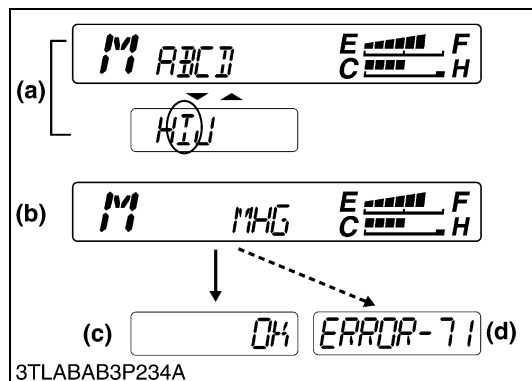

### ■ Adjustment of HST range gear shift lever sensor (for HST Model)

#### ■ NOTE

- When the IntelliPanel or range gear shift sensor was replaced, this adjustment is required.

1. Set the range gear shift lever to the M position.
2. Select mode “I” and then select “H” of the HST model according to above procedure.
3. “OK” is displayed (c) : Lever sensor voltage is as specified.  
“ERROR 71” is displayed (d) with buzzer : Lever sensor voltage is not specified.

In this case;

- Check to see that the range gear shift lever is at M position.
- Check the lever sensor voltage in the Test Mode (Mode “A”) (see page 9-S13). If out of specification, replace the sensor.

4. Turn off the main switch to end the mode “I”.

(a) Mode Selection Display

(b) Information Display

(c) Correct Preserving Display

(d) Error Display

W1021589

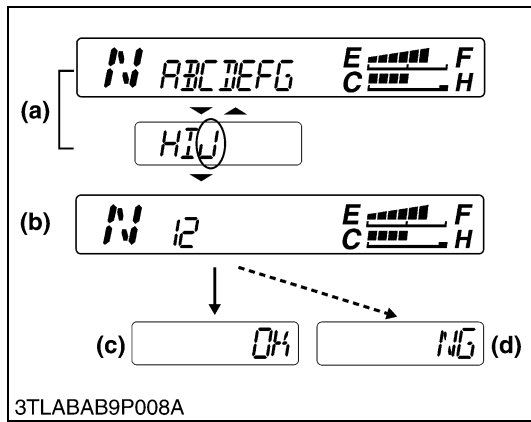

### ■ Speed Unit Selection Mode (Mode “J”)

(Input the traveling speed unit to the IntelliPanel)

1. Select mode “J” (See page 9-S12 “Mode Selection”).
2. “12” is displayed (b), and existing number is flashing.

(Reference)

- “1” : Traveling speed unit is “mph”
  - “2” : Traveling speed unit is “km/h”
3. To change the setting, select an appropriate number, and input to the IntelliPanel. Each time display mode switch is pressed, the flashing number shifts. And then, hold down switch for more than 2 seconds with the number flashing.
  4. “OK” is displayed (c) : The code number has been input correctly.  
“NG” is displayed (d) : The code number has not been input correctly. Repeat the procedure.
  5. Turn off the main switch to end the mode “J”.

(a) Mode Selection Display  
(b) Input Display

(c) Correct Preserving Display  
(d) Incorrect Preserving Display

W1015386

## (2) Checking Electrical Control System



### CAUTION

- For checking of electric circuit, use the circuit tester and test function of IntelliPanel (See page 9-S13).
- As for the checking of sensors, switches and solenoid, do the following order; check the battery, fuse and grounding line first, check by the test function of IntelliPanel next, and check the connectors of panel or electronic control unit. If any defect is found there, check individual sensors, switches or solenoids to see whether the defect exists at the sensor, switch and solenoid side or at the wire harness side.
- When the normal function is restored as the result of replacement of the part which is suspected to see that the trouble is regenerated.

### ■ IMPORTANT

- When connecting or disconnecting the connector for the purpose of checking, be sure to turn OFF the main switch before hand. Moreover, pay attention not to allow the terminal to come in contact with other terminal or chassis while checking.
- When applying the test pin of the tester to the connector terminals, use care not to damage to the connector terminal.

### (A) Check the Fuse and Connector



#### Checking Fuse

1. Check the fuse.
2. If any of the fuses is blown, replace it with the one having same capacity. (Refer to page G-36.)

### ■ IMPORTANT

- If a fuse is blown, check the cause and be sure to replace it with the one having same capacity.

W1034998

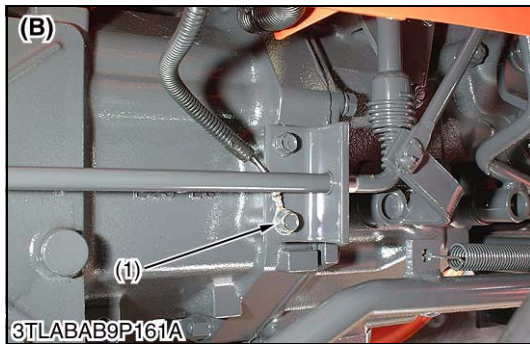
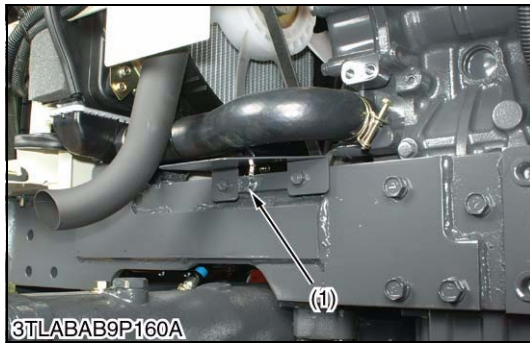

### **Checking Grounding Wire**

1. Check the whether the grounding wire (1) is connected securely to the tractor chassis.
2. If the grounding wire is broken or disconnected, replace it.

(1) Grounding Wire

**(A) Located at Left Side of Front Axle Frame**

**(B) Located at Left Side of Transmission Case**

W1035073

### **Checking Panel Connector**

1. Disconnect the connectors (1), (2) and check their terminals for contamination and deformation.
2. Check to see that cable does not broken or terminals are not shelled off.
3. If any defective parts are found, repair or replace them.

#### **■ IMPORTANT**

- **Connect connectors surely after checked.**

(1) Connector B (16P)

(2) Connector A (20P)

W1035253

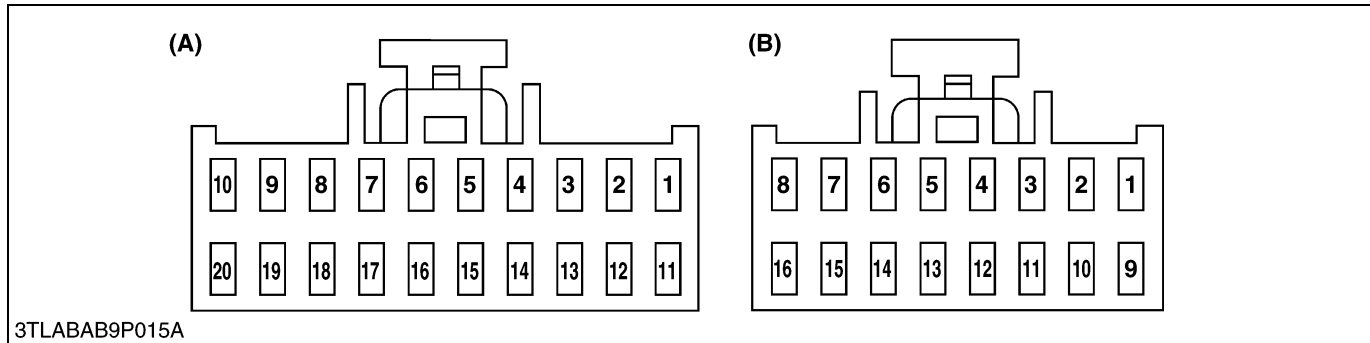
**(B) Checking by Electronic Instrument Panel Connector****(A) Connector A (20P Connector) of Wire Harness Side**

No.	Color of wiring			Terminal Name		
	M/T*	GST	HST	M/T*	GST	HST
1	-			-		
2	Light green / Black			Display mode switch		
3	Blue			Travel speed switch		
4	Brown / Yellow			Low-beam		
5	Red / White	Black / Yellow		Main switch ON		HST pedal neutral switch
6	Black / Red			PTO switch output		
7	Black / Yellow			PTO switch input		
8	Black / Yellow			Shuttle switch		Clutch switch
9	Red / Black	Green / White		PTO speed change switch input	-	
10	-			-		
11	Blue			Oil switch		
12	-			-		
13	White / Red			Charge		
14	Violet			Trailer indicator		
15	-		Violet / White	-		Cruise switch
16	Blue / White	-		PTO speed change switch output	-	
17	Black / White			Main switch ST		
18	Black / White			Turn signal switch RH		
19	Green / Blue			Turn signal switch LH		
20	Black / Red			Glow relay		

\*M/T : Manual Transmission

**(B) Connector B (16P Connector) of Wire Harness Side**

No.	Color of wiring			Terminal Name		
	M/T*	GST	HST	M/T*	GST	HST
1		Red			Power supply 12 V	
2		Black			GND (for circuit line)	
3		Black / Yellow			GND (for sensor)	
4		Brown / White		Check connector	ECU (RS485 (+))	Check connector
5		Brown		Check connector	ECU (RS485 (-))	Check connector
6		–	Yellow		–	HST lever sensor
7		White			Coolant temperature sensor	
8		Yellow / Blue			Fuel unit	
9		Red / Blue			Main switch ON	
10		–	Red / Yellow		–	HST lever sensor
11		Black			GND (for circuit line)	
12		Green / Red			Parking brake switch	
13		–			–	
14		Orange			Traveling speed sensor	
15		Light Green			Engine tachometer sensor	
16		Green / Red			Lighting	

\*M/T : Manual Transmission

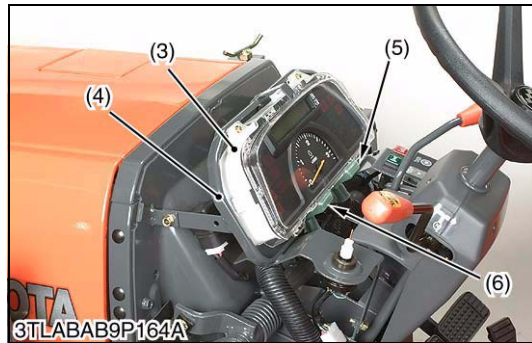
**Disconnecting IntelliPanel Connector**

1. Remove the combination switch (2).
2. Remove the panel cover (1).
3. Disconnect the panel connectors (5), (6).
4. Remove the IntelliPanel (3) from panel frame (4).

- |                        |                       |
|------------------------|-----------------------|
| (1) Panel Cover        | (4) Panel Frame       |
| (2) Combination Switch | (5) Connector A (20P) |
| (3) IntelliPanel       | (6) Connector B (16P) |

W1036395

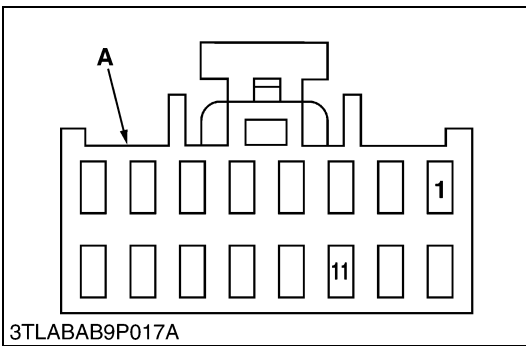

3TLABAB9P017A

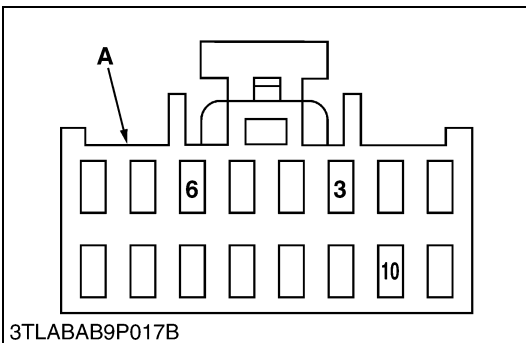

3TLABAB9P017B

### Connector Voltage

#### ■ Main Voltage

1. Measure the voltage between the terminal **1 (+)** and terminal **11 (-)**.
2. If the voltage differs from the battery voltage (11 to 14 V), the wiring harness or battery is faulty.

Voltage	Terminal <b>1</b> to <b>11</b>	Approx. battery voltage
---------	--------------------------------	-------------------------

**A : Connector B (16P) of Wire Harness Side**

W1036564

### Checking HST Range Gear Shift Lever Sensor (HST model)

#### ■ Connector Voltage

1. Turn on the main switch.
2. Measure the voltage between the terminal **10 (+)** and terminal **3 (-)** of the connector **B**.
3. If the voltage is not indicated as table below, wire harness or fuse is faulty.

Voltage	Terminal <b>10</b> to terminal <b>3</b>	Approx. 5 V
---------	---	-------------

#### ■ Sensor Voltage

1. Turn on the main switch.
2. Measure the voltage between the terminal **6 (+)** and terminal **3** of the connector **B** while shifting the range gear shift lever.
3. If the voltage is not indicated as table below, wire harness or lever sensor is faulty.

Lever position	Measuring terminal	Voltage
L	Terminal <b>6</b> to terminal <b>3</b>	Approx. 4.0 V
N		Approx. 3.4 V
M		Approx. 2.5 V
N		Approx. 1.6 V
H		Approx. 1.0 V

**A : Connector B (16P) of Wire Harness Side**

W1045520

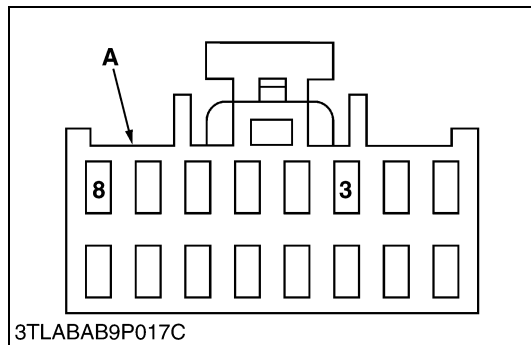

**Checking Fuel Unit**

1. Connect the connectors to the IntelliPanel.
2. Turn on the main switch.
3. Measure the voltage between the terminal **8 (+)** and terminal **3 (-)** of the connector **B**.
4. If the voltage is not indicated as table below, wire harness or fuel unit is faulty.

Voltage	Terminal <b>8</b> to terminal <b>3</b>	0.13 to 3.62 V (E to F)
---------	--	-------------------------

**A : Connector B (16P) of Wire Harness Side**

W1046153

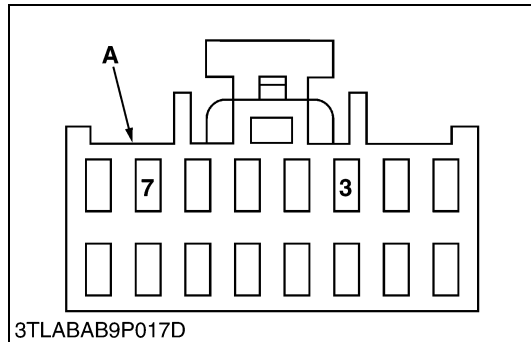
**Checking Coolant Temperature Sensor**

1. Connect the connectors to the IntelliPanel.
2. Turn on the main switch.
3. Measure the voltage between the terminal **7 (+)** and terminal **3 (-)** of the connector **B**.
4. If the voltage is not indicated as table below, wire harness or coolant temperature sensor is faulty.

Voltage	Terminal <b>7</b> to terminal <b>3</b>	0.29 to 2.86 V (60 to 0°C, 140 to 32°F)
---------	--	---

**A : Connector B (16P) of Wire Harness Side**

W1046594

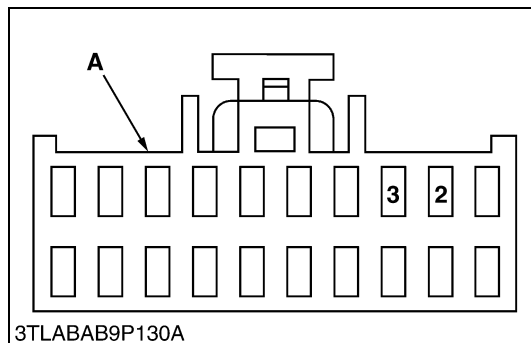
**Checking Display mode Switch and Travel Speed Switch**

1. Connect the connectors to the IntelliPanel.
  2. Turn on the main switch. (Do not start engine.)
- (Display Mode Switch)**
3. Measure the voltage with voltmeter between the terminal **2 (+)** of connector **A** and chassis.
  4. It is OK if the battery voltage (12 V) is indicated while pushing the display mode switch.
- (Travel Speed Switch)**
3. Measure the voltage with voltmeter between terminal **3 (+)** of connector **A** and chassis.
  4. It is OK if the battery voltage (12 V) is indicated while pushing the travel speed switch.

Voltage with switch pushing	Terminal <b>2</b> to chassis	12 V
	Terminal <b>3</b> to chassis	

**A : Connector A (20P) of wire harness Side**

W1046806

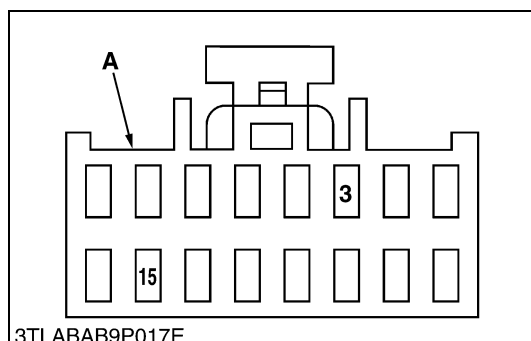
**Checking Engine Tachometer Sensor**

1. Connect the panel connectors to the IntelliPanel.
2. Start the engine.
3. Measure the **AC** voltage between terminal **15** and terminal **3** of connector **B**.
4. If the voltage is not indicated as table below, wire harness or engine tachometer is faulty.

Voltage	Terminal <b>15</b> to terminal <b>3</b>	Approx. AC 2.0 V
---------	---	------------------

**A : Connector B (16P) of Wire Harness Side**

W1047444

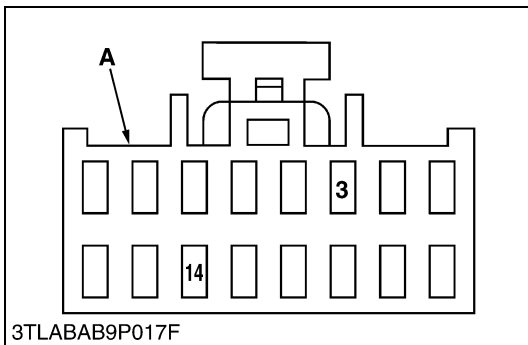

### Checking Traveling Speed Sensor

1. Connect the panel connectors to the IntelliPanel.
2. Jack up front and rear wheels or jack up rear wheels.  
Be sure to shift the front wheel drive lever to 2WD position
3. Start the engine and shift the shift lever or pedal so that the rear wheels can be turn.
4. Measure the **AC** voltage between terminal **14** and terminal **3** of connector **B**.
5. If the voltage is not indicated as table below, wire harness or traveling speed sensor is faulty.

Voltage	Terminal <b>14</b> to terminal <b>3</b>	Approx. AC 2.0 V
---------	---	------------------

**A** : Connector B (16P) of Wire Harness Side

W1048327

### (C) Unit Checking

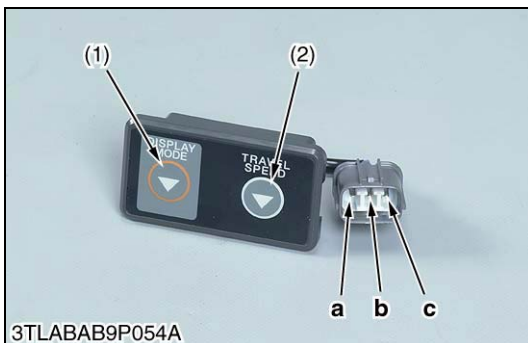

### Display Mode Switch and Travel Speed Switch

1. Check the resistance between the terminal **a** and terminal **c** while pushing the display mode switch (1).
2. It is OK if 0  $\Omega$  is indicated.
3. Check the resistance between the terminal **b** and terminal **c** while pushing the travel speed switch (2).
4. It is OK if 0  $\Omega$  is indicated.

(1) Display Mode Switch

(2) Travel Speed Switch

W1048960



### HST Range Gear Shift Lever Sensor Resistance

1. Measure the resistance between the terminal **a** and terminal **b** while shifting the range gear shift lever.
2. It is OK if the resistance is smoothly changing.

#### (Reference)

- The maximum resistance value is 4.32 to 6.48 k $\Omega$ .

(1) Range Gear Shift Lever Sensor

W1080989

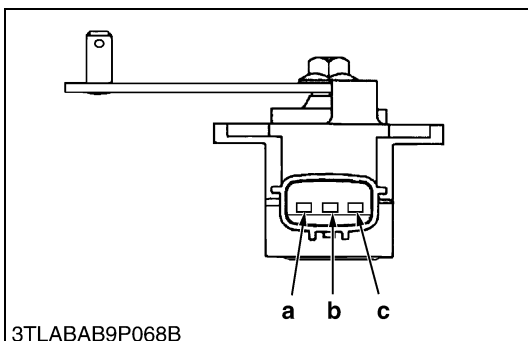

### (3) Checking GST Electric Control System (GST Model Only)

#### (A) Checking Fuse and Connector



##### Checking Fuse

1. Check the fuse.
2. If any of the fuses is blown, replace it with the one having same capacity. (Refer to page G-36.)

##### ■ IMPORTANT

- If a fuse is blown, check the cause and be sure to replace it with the one having same capacity.

W1058136

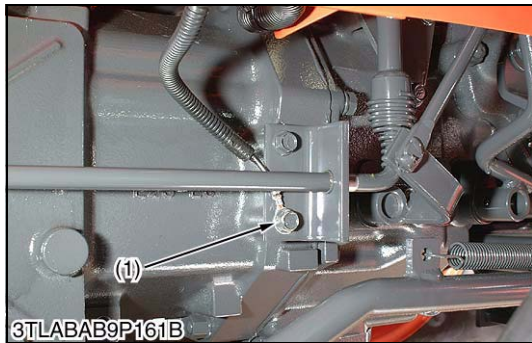

##### Checking Grounding Wire

1. Check the whether the grounding wire (1) is connected securely to the tractor chassis.
2. If the grounding wire is broken or disconnected, replace it.

(1) Grounding Wire

W1058245



##### Checking ECU Connector

1. Disconnect the connector (1), and check their terminals for contamination and deformation.
2. Check to see that cable does not broken or terminals are not shelled off.
3. If any defective parts are found, repair or replace them.

##### ■ IMPORTANT

- Connect connectors surely after checked.

(1) ECU Connector (44P)

W1037538

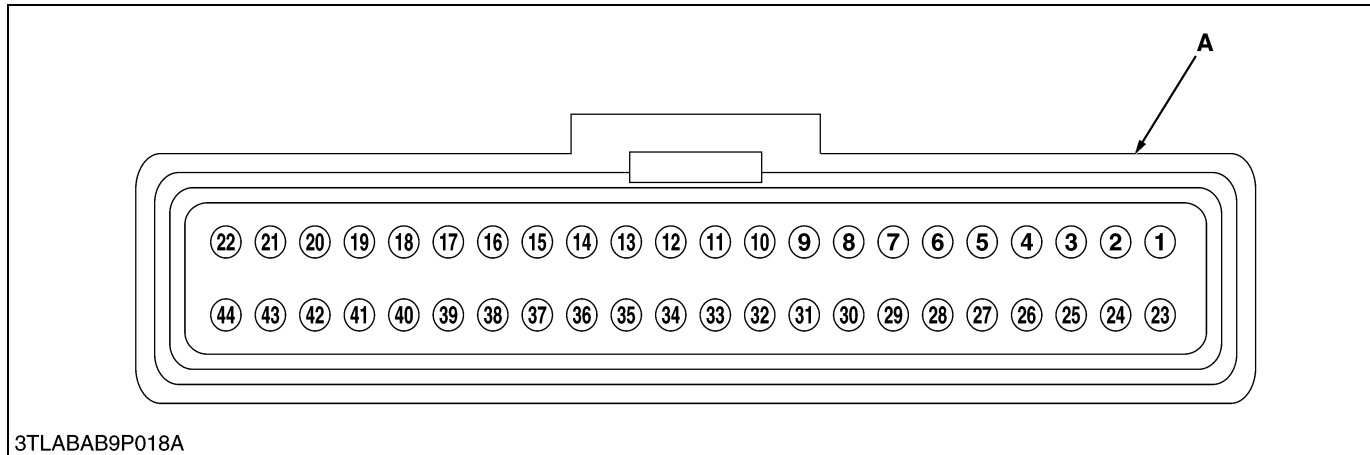
**(B) Checking by Electric Control Unit (ECU)**

No.	Color of wiring	Terminal Name	No.	Color of wiring	Terminal Name
1	—	—	23	Green / White	Output terminal for proportional reducing valve
2	Red / Yellow	Output voltage 12 V (for pressure switch)	24	—	—
3	—	—	25	Brown / Blue	Output terminal for sub-range shift solenoid
4	Red	Output voltage 12 V (for Check connector)	26	Brown / Yellow	Output terminal for main range shift solenoid
5	—	—	27	Brown / Black	Output terminal for 1st shift solenoid
6	—	—	28	Brown / White	Output terminal for 2nd shift solenoid
7	Black	GND (ground for circuit line)	29	Brown / Red	Output terminal for 3rd shift solenoid
8	Red / Yellow	+12 V (power source from main switch)	30	Brown / Green	Output terminal for 4th shift solenoid
9	—	—	31	Red	+12 V (power source from battery)
10	Black / White	GND (ground for oil temp. sensor)	32	Blue / Red	Return line terminal for proportional reducing valve
11	Black / White	GND (ground for check connector)	33	Black / White	GND (ground for sensor)
12	—	—	34	Red / White	+5 V (power source for sensor)
13	—	—	35	Yellow / White	Pressure switch
14	Black / Yellow	Shuttle switch (Neutral)	36	Yellow / Orange	Shuttle switch (Forward)
15	—	—	37	Red / Green	Shuttle switch (Reverse)
16	—	—	38	—	—
17	Orange	Traveling speed sensor	39	Light green	Engine tachometer sensor
18	—	—	40	—	—
19	White / Yellow	Oil temperature sensor	41	—	—
20	—	—	42	White / Green	GST lever sensor
21	Brown / White	RS485 (—)	43	Brown	RS485 (+)
22	Pink	TXD (for check connector)	44	Violet	RXD (for check connector)

**A : ECU Connector of Wire Harness Side**

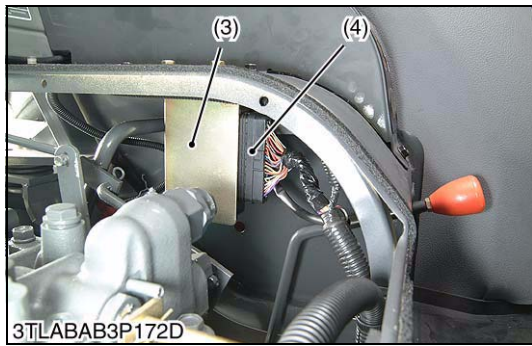
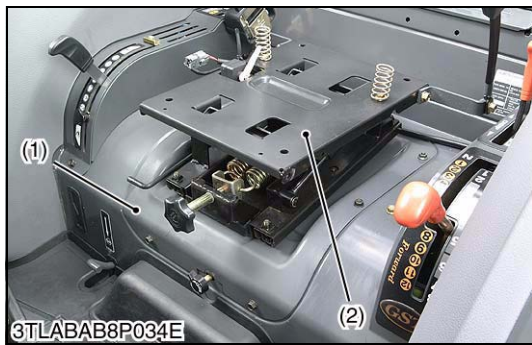

**ECU Connector**

1. Remove the seat.
2. Remove the seat bracket (1) with seat suspension (2) as a unit.
3. Disconnect the ECU connector (4).

- (1) Seat Bracket
- (2) Seat Suspension
- (3) ECU (Electric Control Unit)
- (4) ECU Connector

W1039817

**Connector Voltage**

**(Main Circuit)**

1. Turn on the main switch. (Do not start engine.)
2. Measure the voltage between terminal 31 (+) and terminal 7 (-).
3. It is OK if the voltage equals to the battery voltage.

**(Sensor Voltage)**

1. Turn on the main switch. (Do not start engine.)
2. Measure the voltage between terminal 34 (+) and terminal 33 (-).
3. It is OK if the voltage is approx. 5 V.

Voltage	Terminal 31 to 7	Approx. battery voltage
	Terminal 34 to 33	Approx. 5 V

A : Connector of wire harness side

W1039947

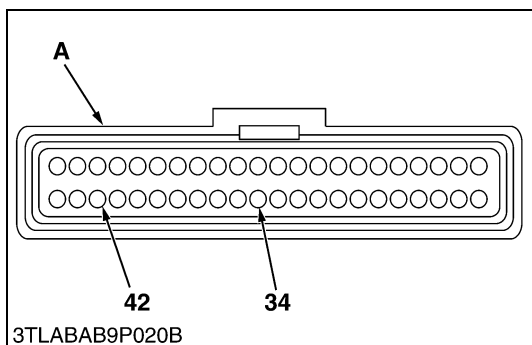
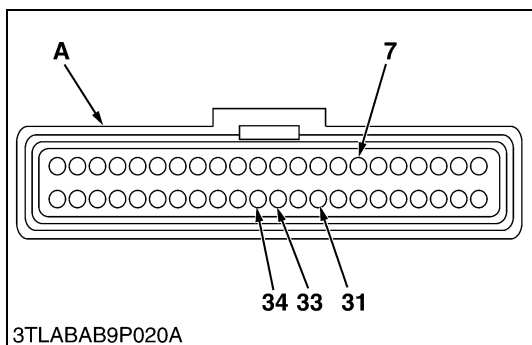

**GST Lever Sensor Voltage**

1. Turn on the main switch. (Do not start engine.)
2. Measure the voltage between terminal 42 (+) and terminal 34 (-).
3. It is OK if the voltage comes to show in the table below.

Voltage between terminal 42 to 34	GST lever at Neutral	Approx. 0.7 V
	GST lever at 8th	Approx. 3.07 V
	GST lever at 12th	Approx. 4.21 V

A : Connector of wire harness side

W1040168



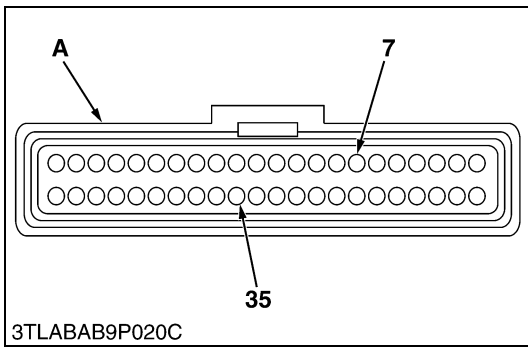

**Pressure Switch Voltage**

1. Connect the **44P** connector to ECU.
2. Connect the tester positive cable to terminal **35** of wire harness side connector and negative cable to terminal **7**.
3. Start the engine and depress the clutch, and shift the shuttle lever to Forward position.
4. Measure the voltage when the GST lever is in neutral and the voltage when GST lever is shifting.
5. It is OK if the voltage comes to show in the table below.

Voltage between terminal <b>35</b> to <b>7</b>	GST lever at Neutral	0 V
	GST lever at Shifting	Above 12 V

**A** : Connector of wire harness side

W1040692

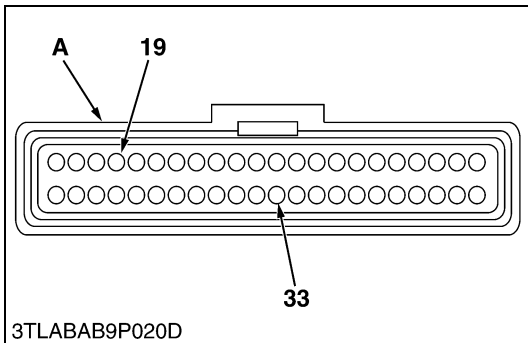

**Oil Temperature Sensor Voltage**

1. Measure the voltage between terminal **19** (+) and terminal **33** (-).
2. It is OK if the voltage value approximates to the value shown in the table below.

Voltage between terminal <b>19</b> to <b>33</b>	Reference value	Approx. 4.7 V at -30°C (-22°F)
		Approx. 3.8 V at 0°C (32°F)
		Approx. 2.3 V at 30°C (86°F)
		Approx. 1.0 V at 60°C (140°F)
		Approx. 0.4 V at 100°C (212°F)

**A** : Connector of wire harness side

W1040859

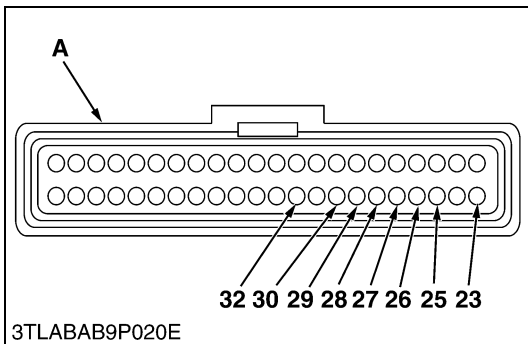

**Proportional Reducing Valve Solenoid Valve Resistance**

1. Measure the resistance between each valve terminal and terminal **32**.
2. It is OK if the resistance value approximates to the value shown in the table below.

Item	Measuring terminal	Resistance
Proportional Reducing valve	Terminal <b>23</b> and <b>32</b>	Approx. 8 to 9 Ω
Solenoid 1	Terminal <b>27</b> and <b>32</b>	Approx. 11 to 15 Ω
Solenoid 2	Terminal <b>28</b> and <b>32</b>	
Solenoid 3	Terminal <b>29</b> and <b>32</b>	
Solenoid 4	Terminal <b>30</b> and <b>32</b>	
Solenoid 5 (Sub-range)	Terminal <b>25</b> and <b>32</b>	
Solenoid 6 (Main range)	Terminal <b>26</b> and <b>32</b>	

W1041158



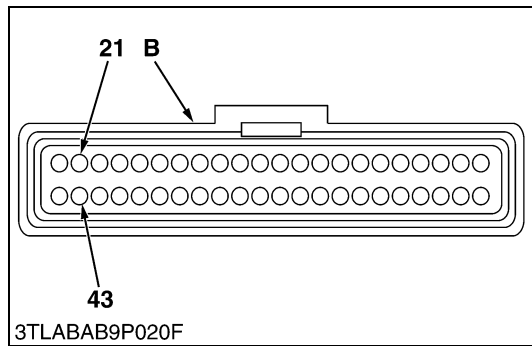
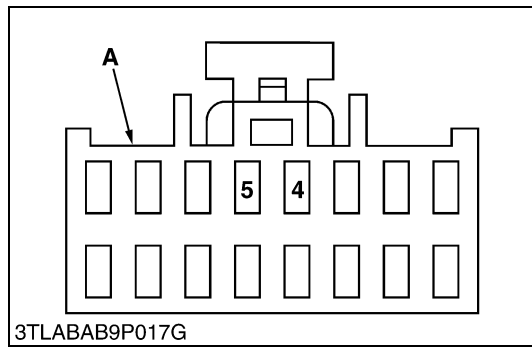

**IntelliPanel and ECU Continuity**

1. Disconnect the connector **B** (16P) from IntelliPanel. (See page 9-S23.)
2. Measure the resistance between terminal **4** of panel connector and terminal **21** of ECU connector, and between terminal **5** of panel connector and terminal **43**.
3. If 0 Ω is not indicated, the wiring harness is faulty.

Resistance	Terminal <b>4</b> of panel connector -Terminal <b>21</b> of ECU connector	0 Ω
	Terminal <b>5</b> of panel connector -Terminal <b>43</b> of ECU connector	

**A** : Panel Connector **B** of Wire Harness Side

**B** : ECU Connector **B** of Wire Harness Side

W1041490

**(C) Checking Sensor and Switch**

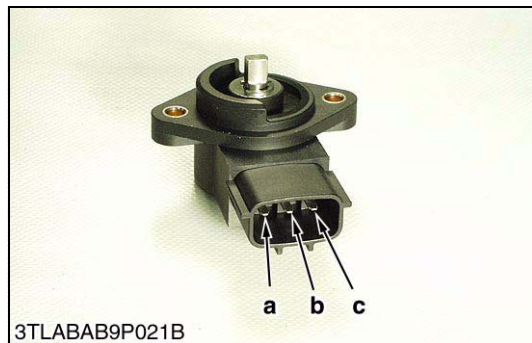

**GST Lever Sensor Resistance**

1. Measure the resistance between terminal **a** and **c** when the shaft is fully turned left.
2. Then, check resistance between terminal **a** and **b** while slowly turning the sensor shaft.
3. It is OK if the resistance value approximates to the value shown in the table below.

**(Reference)**

- The change of resistance can be checking easily when an analog tester is employed.

Resistance	Terminal <b>a</b> - Terminal <b>c</b>	1.6 to 2.4 kΩ
	Terminal <b>a</b> - Terminal <b>b</b>	Resistance is normal if smoothly changing

W1041711



**Pressure Switch Resistance**

1. Disconnect the pressure switch connector (1).
2. Connect the circuit tester pins to each terminal of pressure switch (2).
3. Start the engine and depress the clutch pedal.
4. Check the resistance at time when shuttle lever or GST lever is shifted.
5. It is OK if the resistance comes to have shown in the table below.

**CAUTION**

- Be sure to depress the clutch pedal so that the tractor should not move while shifting each lever.

Resistance between terminals	When the shuttle lever or GST lever is shifted	Continuity exists
	Both levers are at Neutral	0 Ω

(1) Pressure Switch Connector

(2) Pressure Switch

W1042028

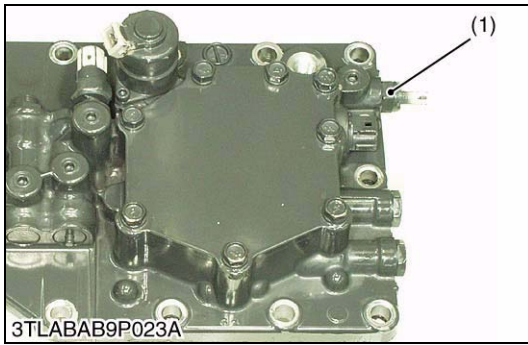

**Oil Temperature Sensor Resistance**

1. Measure the resistance between the sensor terminals.
2. It is OK if the resistance value approximates to the value shown in the table below.
3. If there exists a large difference, replace the sensor.

Resistance	Reference value	16.4 to 21.1 kΩ at -20°C (-4°F) 1.04 to 1.23 kΩ at 40°C (104°F) 0.15 to 0.16 kΩ at 100°C (212°F)
------------	-----------------	--

(1) Oil Temperature Sensor

W1042316

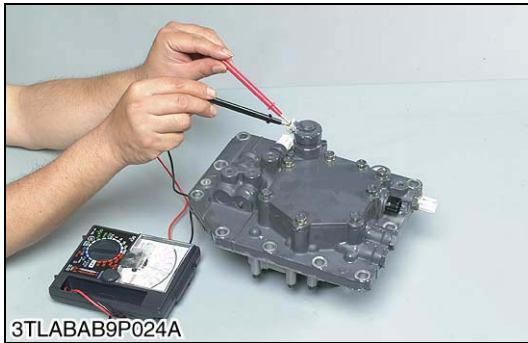

**Proportional Reducing Valve Resistance**

1. Measure the resistance between the valve terminals.
2. It is OK if the resistance comes to have shown in the table below.

Resistance	Reference value	8 to 9 Ω
------------	-----------------	----------

W1042539

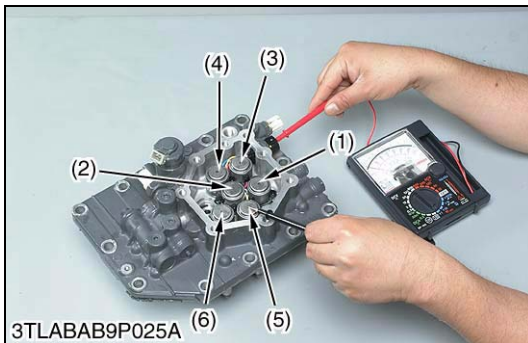

**Shift Solenoid Resistance**

1. Measure the resistance between each connector terminal and each valve body.
2. It is OK if the resistance comes to have shown in the table below.

Measuring point		Resistance
Solenoid	Connector terminal	
(1) Solenoid 1	1	11 to 15 Ω
(2) Solenoid 2	2	
(3) Solenoid 3	3	
(4) Solenoid 4	4	
(5) Solenoid 5 (Sub-range)	5	
(6) Solenoid 6 (Main range)	6	

A : Connector of Solenoid Side

W1042693

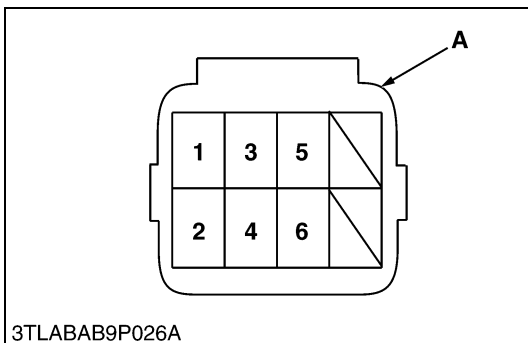

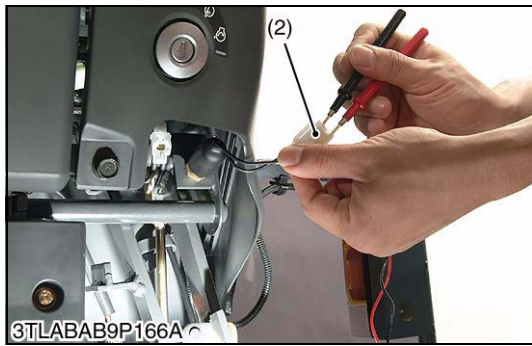
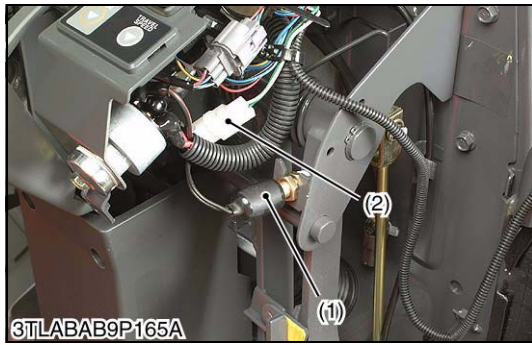

**Brake Lamp Switch Continuity**

1. Disconnect the connector, and measure the resistance with an ohmmeter between connector terminal.
2. If the measurement differs from the table below, the brake switch is faulty.

Resistance between connector terminals	When brake pedal is released	Infinity
	When brake pedal is depressed	0 Ω

(1) Brake Lamp Switch

(2) Brake Lamp Switch Connector

W1024163

**[3] STARTING SYSTEM**

**(1) Checking**

**(A) Main Switch (ROPS Type)**

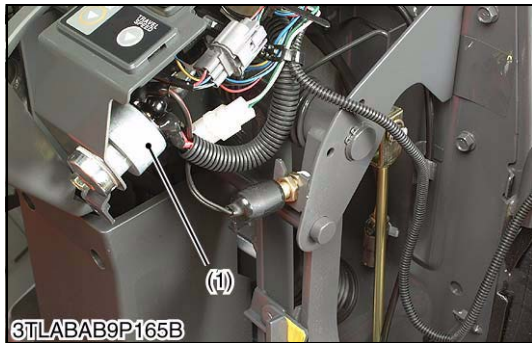

**Remove the Main Switch**

1. Remove the combination switch.
2. Remove the panel cover.
3. Disconnect the main switch connector.
4. Perform the following checking.

(1) Main Switch

W1013848

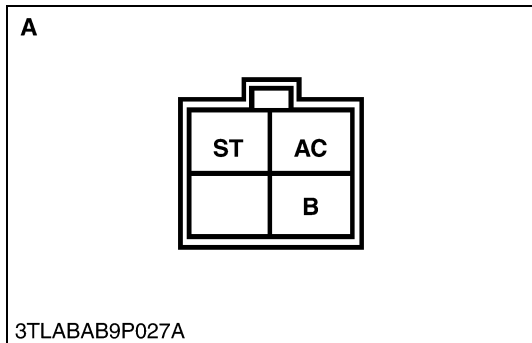

**Connector Voltage**

1. Measure the voltage between the terminal **B** and chassis.
2. If the voltage differs from the battery voltage (11 to 14 V), the wiring harness is faulty.

Voltage	Terminal <b>B</b> – Chassis	Approx. battery voltage
---------	-----------------------------	-------------------------

**A : Wire Harness Side Connector 4C**

W1014366

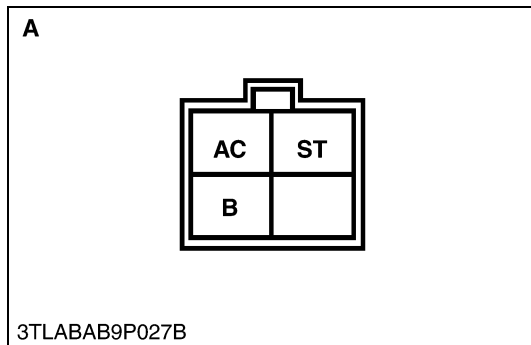
**Main Switch at ON Position**

1. Turn the main switch **ON** position.
2. Measure the resistance between the terminal **B** and the terminal **AC**.
3. If  $0\ \Omega$  is not indicated, renew the main switch.

Resistance	Terminal <b>B</b> – Terminal <b>AC</b>	$0\ \Omega$
------------	---	-------------

**A : Main Switch Side Connector 4C**

W1014494

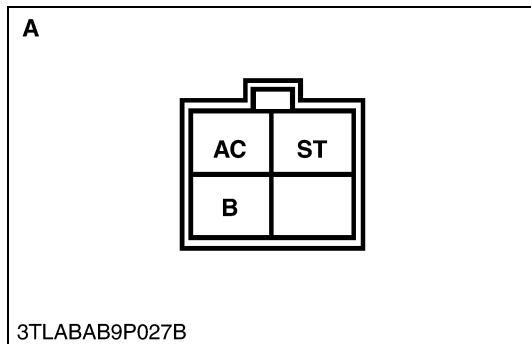
**Main Switch at START Position**

1. Turn and hold the main switch at the **START** position.
2. Measure the resistances between the terminal **B** and the terminal **AC**, and between the terminal **B** and the terminal **ST**.
3. If  $0\ \Omega$  is not indicated, renew the main switch.

Resistance	Terminal <b>B</b> – Terminal <b>AC</b>	$0\ \Omega$
	Terminal <b>B</b> – Terminal <b>ST</b>	$0\ \Omega$

**A : Main Switch Side Connector 4C**

W1014907

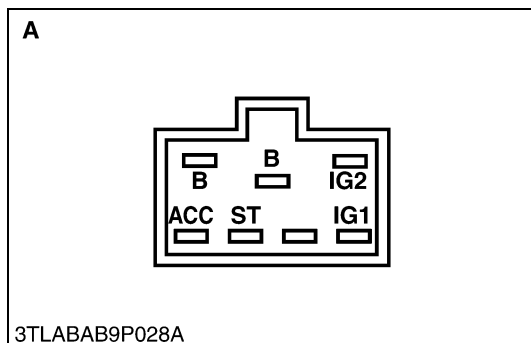
**(B) Main Switch (CABIN Type)****Connector Voltage**

1. Measure the voltage between the terminal **B** and chassis.
2. If the voltage differs from the battery voltage (11 to 14 V), the wiring harness is faulty.

Voltage	Terminal <b>B</b> – Chassis	Approx. battery voltage
---------	--------------------------------	-------------------------

**A : Wire Harness Side Connector 6G**

W1014732

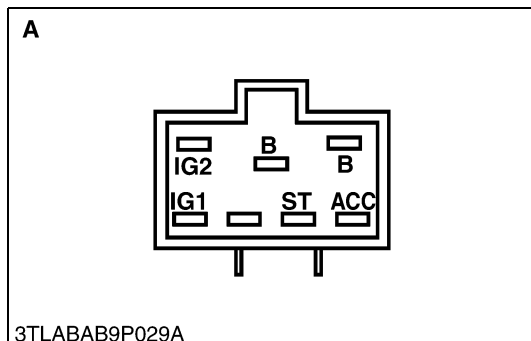
**Main Switch at ACC Position**

1. Turn the main switch **ACC** position.
2. Measure the resistance between the terminal **B** and the terminal **ACC**.
3. If  $0\ \Omega$  is not indicated, renew the main switch.

Resistance	Terminal <b>B</b> – Terminal <b>ACC</b>	$0\ \Omega$
------------	--	-------------

**A : Main Switch Side Connector 6G**

W1014824

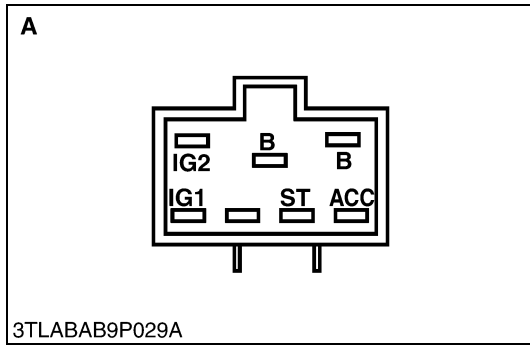

**Main Switch at Key ON Position**

1. Turn and hold the main switch at the **ON** position.
2. Measure the resistances between the terminal **B** and the terminal **ACC**, the terminal **IG1**, the terminal **IG2**.
3. If 0 Ω is not indicated, renew the main switch.

Resistance	Terminal <b>B</b> – Terminal <b>ACC</b>	0 Ω
	Terminal <b>B</b> – Terminal <b>IG1</b>	0 Ω
	Terminal <b>B</b> – Terminal <b>IG2</b>	0 Ω

**A : Main Switch Side Connector 6G**

W1014641

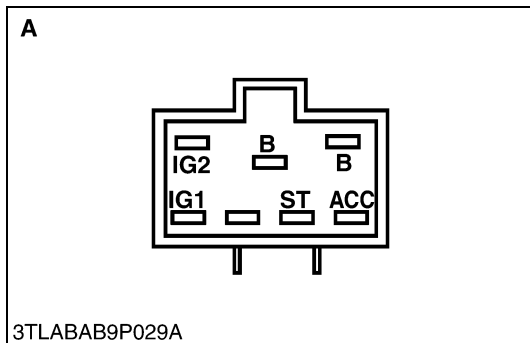

**Main Switch at START Position**

1. Turn and hold the main switch at the **START** position.
2. Measure the resistances between the terminal **B** and the terminal **IG1**, the terminal **ST**.
3. If 0 Ω is not indicated, renew the main switch.

Resistance	Terminal <b>B</b> – Terminal <b>IG1</b>	0 Ω
	Terminal <b>B</b> – Terminal <b>ST</b>	0 Ω

**A : Main Switch Side Connector 6G**

W1015222

**(C) Safety Switch**



**PTO Switch Continuity**

1. Disconnect the PTO switch connector (1).
2. Measure the resistance between connector terminal as shown in table below.
3. If the switch is defective, replace it.

Resistance between connector terminal	When switch spring is pushed (Neutral)	0 Ω
	When switch spring is Released	Infinity

- (1) PTO Switch Connector  
 (2) PTO Switch

- (3) Connector of Switch Side

W1044513

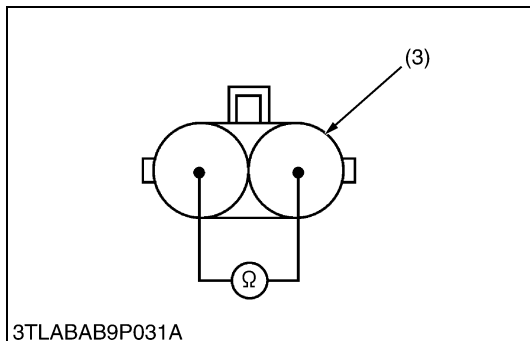



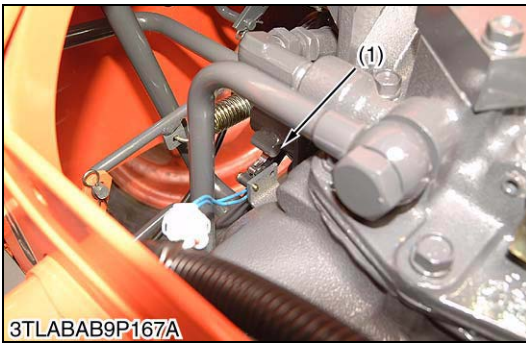

**PTO Speed Change Switch Continuity (For Manual Transmission Model)**

1. Disconnect the PTO speed change switch connector.
2. Measure the resistance between connector terminal as shown in table below.
3. If the switch is defective, replace it.

Resistance between connector terminal	When switch spring is pushed (Neutral)	0 Ω
	When switch spring is Released	Infinity

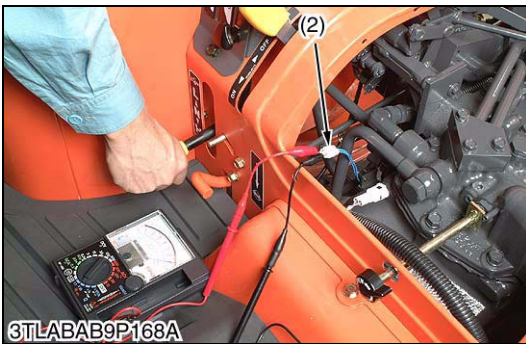

(1) PTO Speed Change Switch                      (2) Connector of Switch Side

W1042180



**Shuttle Switch Continuity (For Manual Transmission and GST Model)**

**(Shuttle Switch)**

1. Remove the steering post under cover.
2. Disconnected the shuttle switch connector (1).
3. Measure the resistance across four terminal referring to the table below.

Shuttle lever position	Connector terminal						Resistance
	F	N1	N2	R	COM1	COM2	
Forward	●				●		0 Ω
Neutral		●	●		●	●	
Reverse				●	●		

4. If 0 Ω is not indicated, the shuttle switch is faulty.

**(Reference)**

- There are only terminal **N1** and **COM1** for manual transmission model.

(1) Shuttle Switch    (2) Connector of Switch Side

W1044817

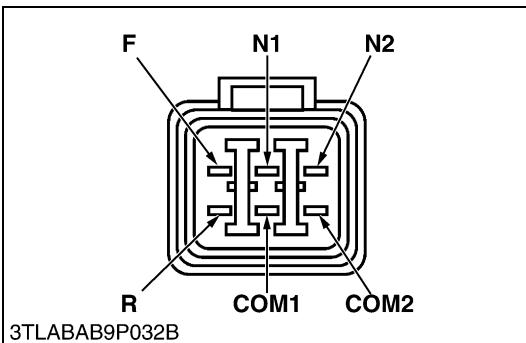



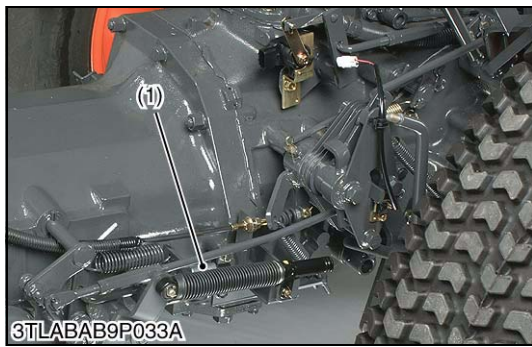

**HST Pedal Switch (For HST Model)**

1. Disconnect the HST neutral switch connector.
2. Remove the HST neutral switch (1).
3. Push the switch and measure the resistance between terminal 1 and 2, and between terminal 3 and 4.
4. If 0 Ω is not indicated, switch is faulty.

Resistance while pushing the switch	Terminal 1 - 2	0 Ω
	Terminal 3 - 4	

(1) HST Neutral Switch

(2) Switch Connector

W1045046

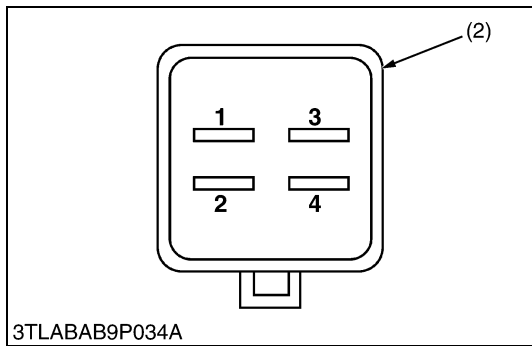

**Clutch Pedal Switch (For HST Model)**

1. Remove the panel cover.
2. Disconnect the clutch pedal switch connector (2).
3. Measure the resistance between connector terminals while pushing the clutch pedal switch.
4. If 0 Ω is not indicated, switch is faulty.

(1) Clutch Pedal Switch

(2) Clutch Pedal Switch Connector

W1045306

**(D) Starter and Starter Relay**



**Starter Motor B Terminal Voltage**

1. Measure the voltage between the B terminal and chassis.
2. If the voltage differs from the battery voltage, check the battery's cable.

Voltage	Factory spec.	Approx. battery voltage
---------	---------------	-------------------------

W1016256

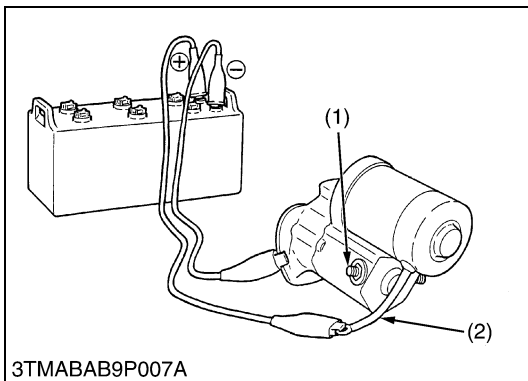

### Motor Test

#### ⚠ CAUTION

- **Secure the starter to prevent it from jumping up and down while testing the motor.**

1. Disconnect the battery negative cable from the battery.
2. Disconnect the battery positive cable and the leads from the starter **B** terminal.
3. Remove the starter from the engine.
4. Disconnect the connecting lead (2) from the starter **C** terminal (1).
5. Connect a jumper lead from the connecting lead (2) to the battery positive terminal post.
6. Connect a jumper lead momentarily between the starter motor housing and the battery negative terminal post.
7. If the motor does not run, check the motor.

(1) C Terminal

(2) Connecting Lead

W10142670

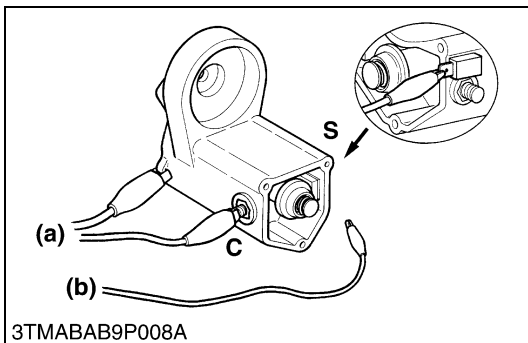

### Magnet Switch Test (Pull-in, Holding Coils)

1. Remove the motor from the starter housing.
2. Prepare a 12 V battery for the test.
3. Connect jumper leads from the battery negative terminal to the housing and the starter **C** terminal.
4. The plunger should be attached and the pinion gear should pop out when a jumper lead is connected from the battery positive terminal to the **S** terminal. It's a correct.
5. Disconnect the jumper lead to the starter **C** terminal. Then the pinion gear should remain popped out. It's a correct.

#### ■ IMPORTANT

- **Testing time must be 3 to 5 sec..**

(a) To Negative Terminal

(b) To Positive Terminal

W10146900

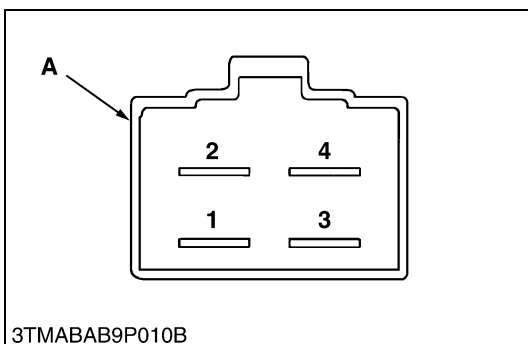

### Checking Starter Relay

1. Remove the panel cover and meter panel. (See page 9-S23.)
2. Remove the starter relay.
3. Apply battery voltage between the terminal **3** and the terminal **4**, and check the continuity of between the terminal **1** and the terminal **2**.
4. If the continuity is not established, renew the starter relay.

A : Connector of Starter Relay

W1026991

**(E) Glow Control System**

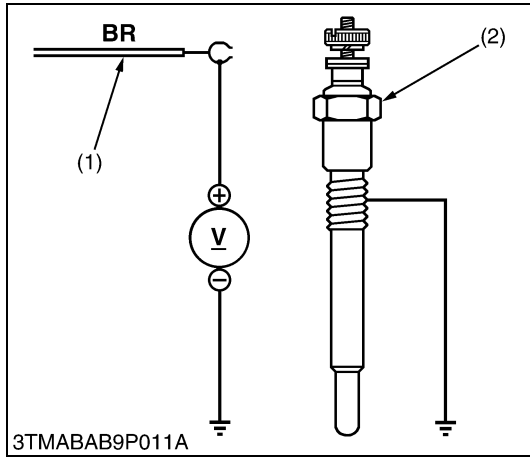

**Glow Plug Lead Terminal Voltage**

1. Disconnect the wiring lead (1) from the glow plug (2) after turning the main switch off.
2. Turn the main switch key to the “ON” position, and measure the voltage between the lead terminal and the chassis.
3. Turn the main switch key to the “START” position, and measure the voltage between the lead terminal and the chassis.
4. If the voltage at either position differs from the battery voltage, the wiring harness or main switch is faulty.

Voltage (Lead terminal – Chassis)	Main switch key at “ON”	Approx. battery voltage
	Main switch key at “START”	Approx. battery voltage

(1) Wiring Lead (Positive)

(2) Glow Plug

W10149130

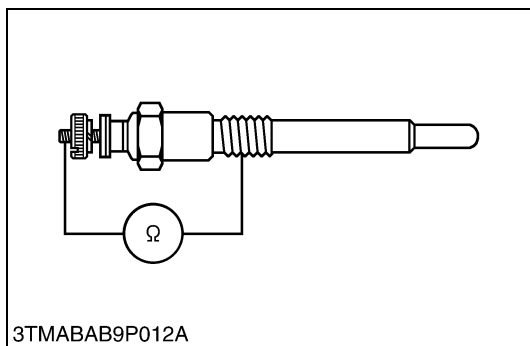

**Glow Plug Continuity**

1. Disconnect the lead from the glow plugs.
2. Measure the resistance between the glow plug terminal and the chassis.
3. If 0 Ω is indicated, the screw at the tip of the glow plug and the housing are short-circuited.
4. If the factory specification is not indicated, the glow plug is faulty.

Glow plug resistance	Factory spec.	Approx. 0.9 Ω
----------------------	---------------	---------------

W10151150

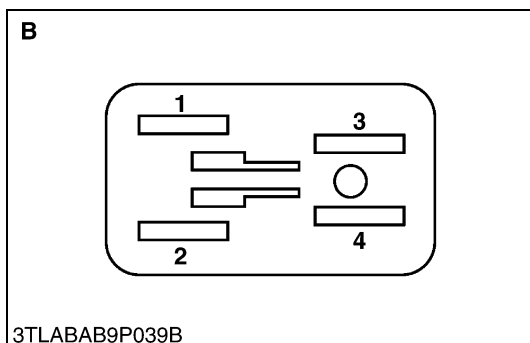
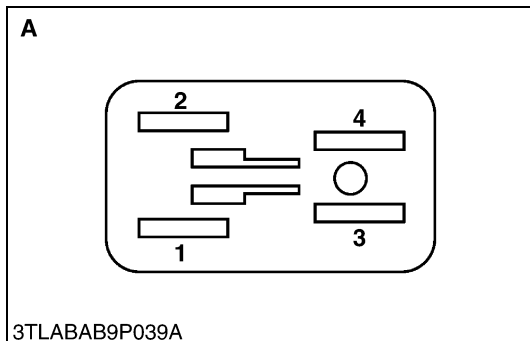

**Glow Relay**

**1) Connector Voltage**

1. Turn the main switch off.
2. Disconnect the 4P connector from glow relay.
3. Measure the voltage across the terminal 3 (Positive) and chassis (Negative).
4. If the voltage differs from the battery voltage, the wiring harness is faulty.
5. Turn the main switch on.
6. Measure the voltage across the terminal 1 (Positive) and chassis (Negative).
7. If the voltage differs from the battery voltage, the wiring harness is faulty.

**2) Glow Relay Test**

1. Remove the glow relay.
2. Apply battery voltage between the terminal 3 and the terminal 4, and check the continuity of the terminal 1 and the terminal 2.
3. If the continuity is not established between terminal 1 and the terminal 2, replace the glow relay.

**A : Connector of Wire Harness Side    B : Connector of Glow Relay**

W1014050

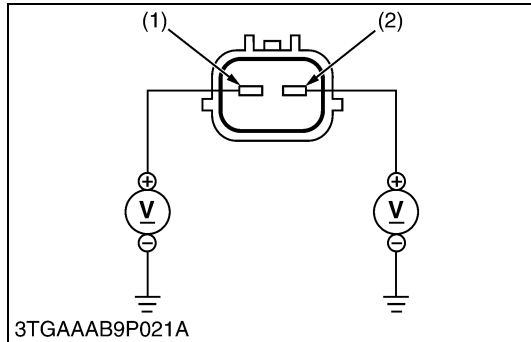
**(F) Engine Stop Solenoid****Connector Voltage**

1. Disconnect the **2P** connector from engine stop solenoid.
2. Turn the main switch key to the “**ON**” position.
3. Measure the voltage between the terminal **1** (1), terminal **2** (2) and body.
4. If the voltage differs from the battery voltage, the wiring harness or main switch is faulty.

Voltage	Terminal 1 – Body	Approx. battery voltage
	Terminal 2 – Body	

(1) Terminal 1

(2) Terminal 2

W1015556

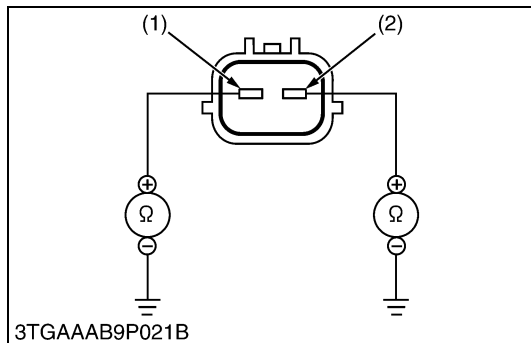
**Stop Solenoid Coil**

1. Disconnect the **2P** connector from engine stop solenoid.
2. Measure the resistance between the terminal **1**, terminal **2** and body.
3. If the resistance differs from the factory specification, the coil is faulty.

Resistance	Terminal 1 – Body	Approx. 0.375 Ω
	Terminal 2 – Body	Approx. 15.6 Ω

(1) Terminal 1 (Pulling Coil)

(2) Terminal 2 (Holding Coil)

W1015848

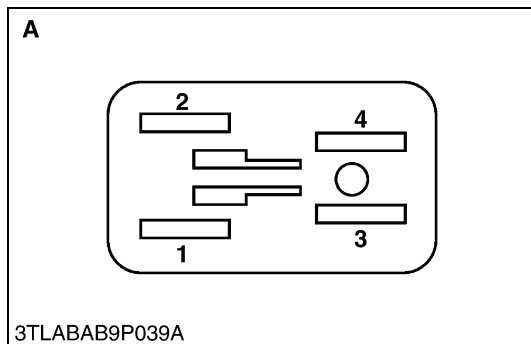
**Engine Stop Solenoid Relay****1) Connector Voltage**

1. Turn the main switch off.
2. Disconnect the **4P** connector from engine stop solenoid relay.
3. Measure the voltage between the terminal **3** (Positive) and chassis (Negative).
4. If the voltage differs from the battery voltage, the wiring harness is faulty.
5. Turn the main switch on.
6. Measure the voltage between the terminal **1** (Positive) and chassis (Negative).
7. If the voltage differs from the battery voltage, the wiring harness is faulty.

**2) Engine Stop Solenoid Relay**

1. Remove the engine stop solenoid relay.
2. Apply battery voltage between the terminal **3** and the terminal **4**, and check the continuity of the terminal **1** and the terminal **2**.
3. If the continuity is not established across terminal **1** and **2**, replace the engine stop solenoid relay.

**A** : Connector of Wire Harness Side    **B** : Connector of Engine Stop Solenoid Relay

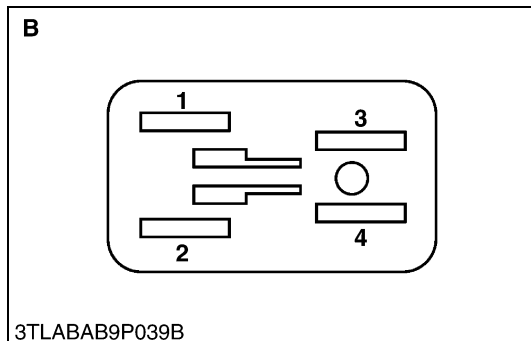

W1053582

## (2) Disassembling and Assembling

### (A) Starter

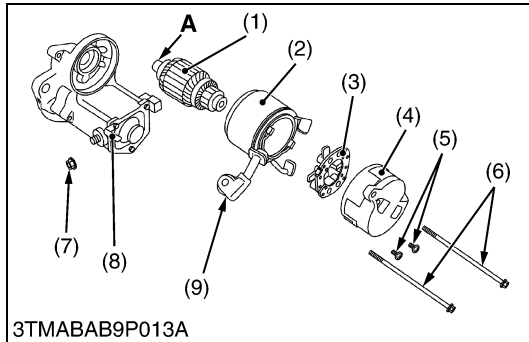

3TMABAB9P013A

#### Disassembling Motor

1. Disconnect the connecting lead (9) from the magnet switch (8).
2. Remove the screws (6), and then separate the end frame (4), yoke (2) and armature (1).
3. Remove the two screws (5), and then take out the brush holder (3) from the end frame (4).

#### (When reassembling)

- Apply grease to the spline teeth **A** of the armature (1).

Tightening torque	Nut (7)	5.9 to 11.8 N·m 0.6 to 1.2 kgf·m 4.3 to 8.7 ft·lbs
-------------------	---------	--

- |                  |                         |
|------------------|-------------------------|
| (1) Armature     | (7) Nut                 |
| (2) Yoke         | (8) Magnet Switch       |
| (3) Brush Holder | (9) Connecting Lead     |
| (4) End Frame    |                         |
| (5) Screw        | <b>A : Spline Teeth</b> |
| (6) Screw        |                         |

W10162880

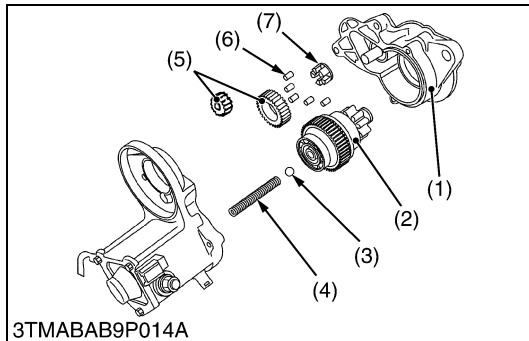

3TMABAB9P014A

#### Disassembling Magnet Switch

1. Remove the drive end frame (1) mounting screws.
2. Take out the overrunning clutch (2), ball (3), spring (4), gears (5), rollers (6) and retainer (7).

#### (When reassembling)

- Apply grease to the gear teeth of the gears (5) and overrunning clutch (2), and ball (3).

- |                        |              |
|------------------------|--------------|
| (1) Drive End Frame    | (5) Gear     |
| (2) Overrunning Clutch | (6) Roller   |
| (3) Ball               | (7) Retainer |
| (4) Spring             |              |

W10167280

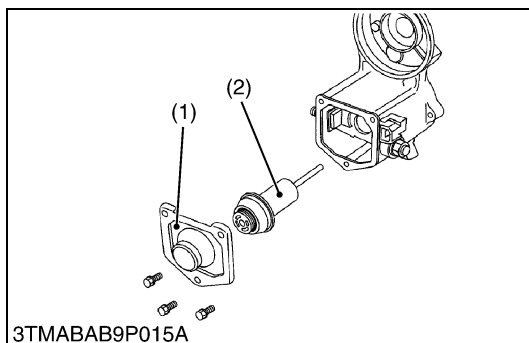

3TMABAB9P015A

#### Plunger

1. Remove the end cover (1).
2. Take out the plunger (2).

- |               |             |
|---------------|-------------|
| (1) End Cover | (2) Plunger |
|---------------|-------------|

W10168830

### (3) Servicing

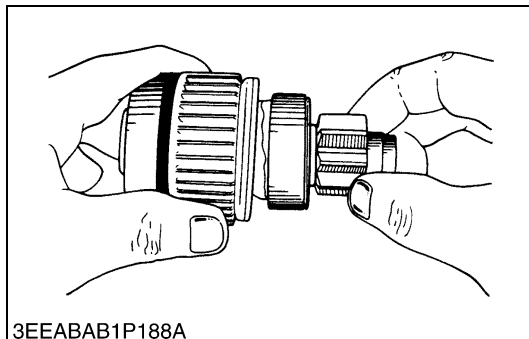

3EEABAB1P188A

#### Overrunning Clutch

1. Inspect the pinion for wear or damage.
2. If there is any defect, replace the overrunning clutch assembly.
3. Check that the pinion turns freely and smoothly in the overrunning direction and does not slip in the cranking direction.
4. If the pinion slips or does not rotate in the both directions, replace the overrunning clutch assembly.

W10169900

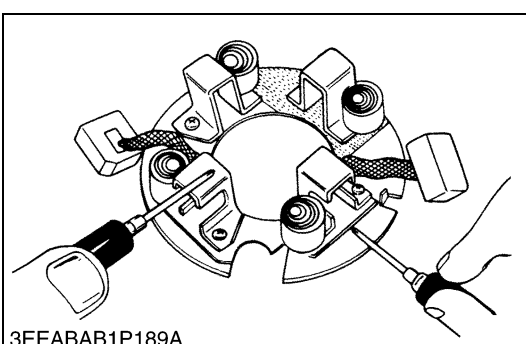
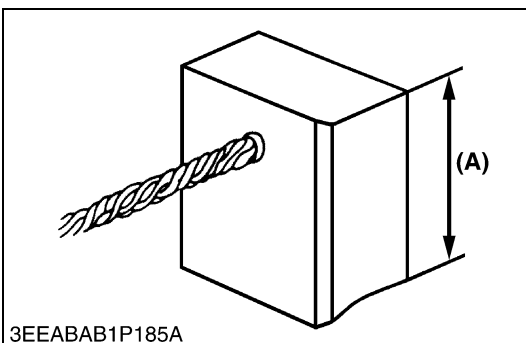
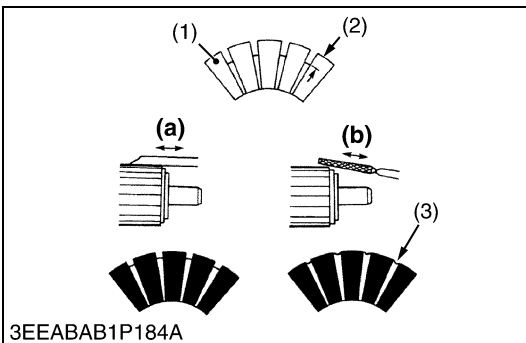
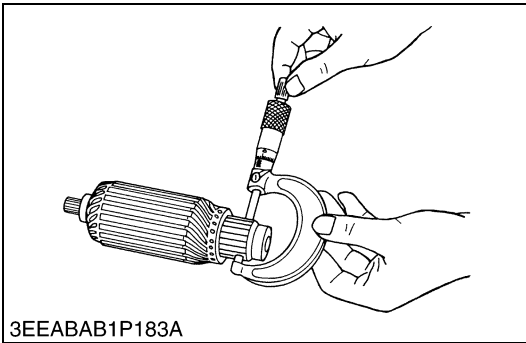
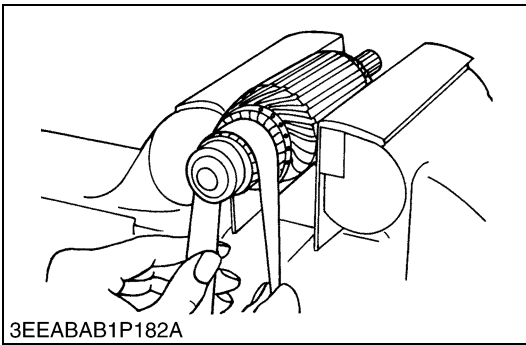

**Commutator and Mica**

1. Check the contact face of the commutator for wear, and grind the commutator with emery paper if it is slightly worn.
2. Measure the commutator O.D. with an outside micrometer at several points.
3. If the minimum O.D. is less than the allowable limit, replace the armature.
4. If the difference of the O.D.'s exceeds the allowable limit, correct the commutator on a lathe to the factory specification.
5. Measure the mica undercut.
6. If the undercut is less than the allowable limit, correct it with a saw blade and chamfer the segment edges.

Commutator O.D.	Factory spec.	30.0 mm 1.181 in.
	Allowable limit	29.0 mm 1.142 in.

Difference of O.D.'s	Factory spec.	Less than 0.02 mm 0.0008 in.
	Allowable limit	0.05 mm 0.0020 in.

Mica undercut	Factory spec.	0.50 to 0.80 mm 0.0197 to 0.0315 in.
	Allowable limit	0.20 mm 0.0079 in.

- (1) Segment
- (2) Undercut
- (3) Mica
- (a) Correct
- (b) Incorrect

W10170920

**Brush Wear**

1. If the contact face of the brush is dirty or dusty, clean it with emery paper.
2. Measure the brush length **A** with vernier calipers.
3. If the length is less than the allowable limit, replace the yoke assembly and brush holder.

Brush length A	Factory spec.	15.0 mm 0.591 in.
	Allowable limit	11.0 mm 0.433 in.

W10175440

**Brush Holder**

1. Check the continuity across the brush holder and the holder support with an ohmmeter.
2. If there is continuity, replace the brush holder.

Resistance	Brush holder – Holder support	Infinity
------------	----------------------------------	----------

W10176720



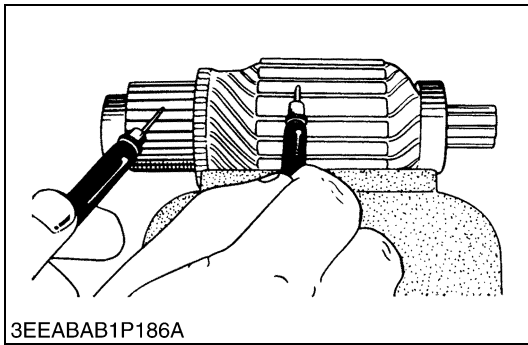

### Armature Coil

1. Check the continuity across the commutator and armature coil core with an ohmmeter.
2. If there is continuity, replace the armature.
3. Check the continuity across the segments of the commutator with an ohmmeter.
4. If there is continuity, replace the armature.

W10177670

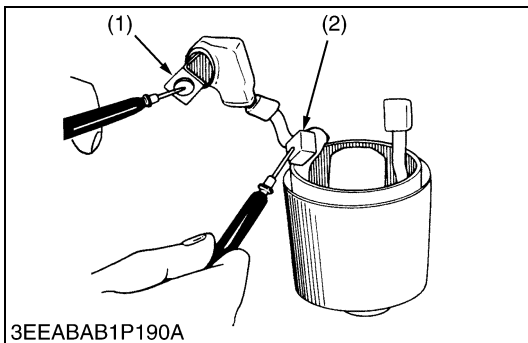
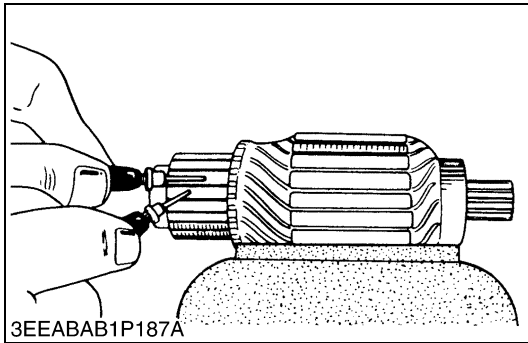

### Field Coil

1. Check the continuity of the lead (1) and brush (2) with an ohmmeter.
2. If it does not conduct, replace the yoke assembly.
3. Check the continuity of the brush (2) and yoke (3) with an ohmmeter.
4. If it conducts, replace the yoke assembly.

(1) Lead  
(2) Brush

(3) Yoke

W10180150

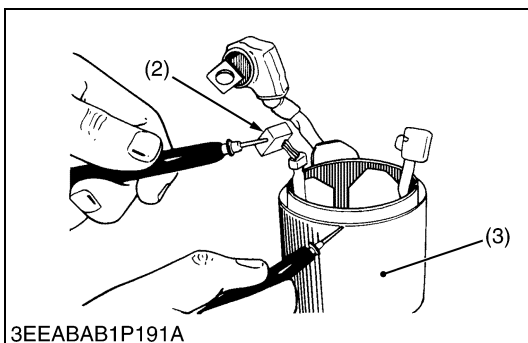

## [4] CHARGING SYSTEM

### (1) Checking

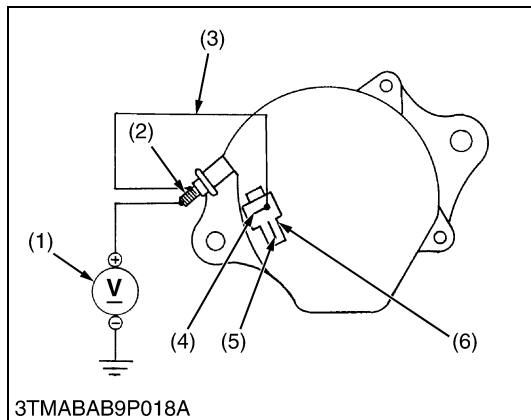
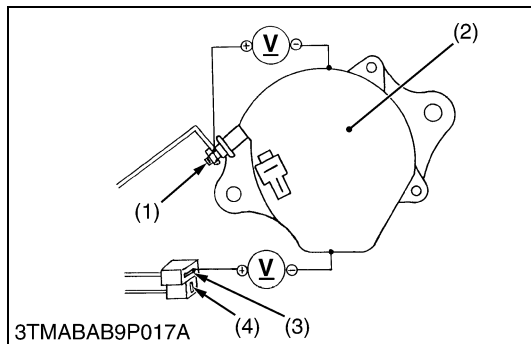
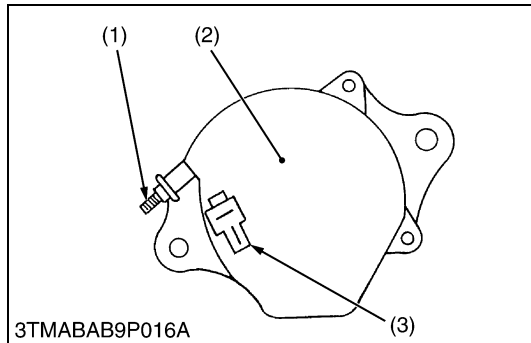

#### Alternator

1. Disconnect the **2P** connector (3) from alternator after turning the main switch **OFF**.
2. Perform the following checkings.

- (1) **B** Terminal (3) **2P** Connector  
 (2) Alternator

W10181750

#### Connector Voltage

1. Turn the main switch **OFF**. Measure the voltage between the terminal **B** (1) and the chassis.
2. Turn the main switch **ON**. Measure the voltage between the terminal **IG** (3) and the chassis.

Voltage (Main switch at <b>OFF</b> )	Terminal <b>B</b> – Chassis	Approx. battery voltage
Voltage (Main switch at <b>ON</b> )	Terminal <b>IG</b> – Chassis	Approx. battery voltage

- (1) Terminal **B** (3) Terminal **IG**  
 (2) Alternator (4) Terminal **L**

W10182790

#### No-Load Test

1. Connect the **2P** connector (6) to previous positions of the alternator after turning the main switch **OFF**.
2. Connect the jumper lead (3) between terminal **IG** (4) and terminal **B** (2).
3. Start the engine and then set at idling speed.
4. Disconnect the negative cable from the battery.
5. Measure the voltage between the terminal **B** (2) and the chassis.
6. If the measurement is less than the factory specification, disassemble the alternator and check the IC regulator.

Voltage	Factory spec.	More than 14 V
---------	---------------	----------------

#### (Reference)

- Once the engine has started, the alternator temperature rises quickly up to an ambient temperature of 70 to 90 °C (158 to 194 °F). As the temperature goes higher than 50 °C (122 °F), the alternator voltage slowly drops; at higher than 100 °C (212 °F), it drops by about 1 V.

- (1) Voltmeter (4) Terminal **IG**  
 (2) Terminal **B** (5) Terminal **L**  
 (3) Jumper Lead (6) **2P** Connector

W10184780

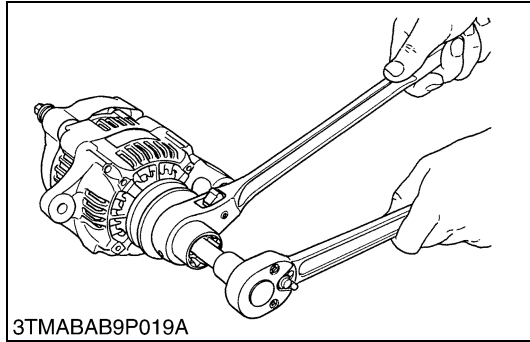
**(2) Disassembling and Assembling****Pulley**

1. Secure the hexagonal end of the pulley shaft with a double-ended ratchet wrench as shown in the figure, loosen the pulley nut with a socket wrench and remove it.

**(When reassembling)**

Tightening torque	Pulley nut	58.3 to 78.9 N·m 5.95 to 8.05 kgf·m 43.0 to 58.2 ft·lbs
-------------------	------------	---

W10187280

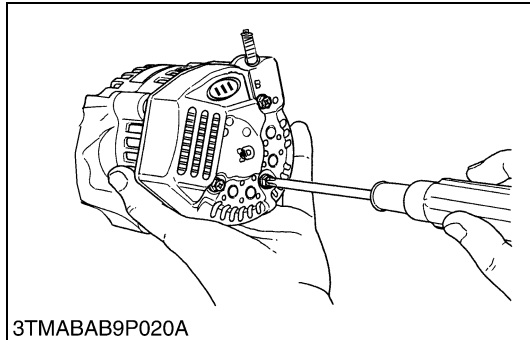
**Rear End Cover**

1. Unscrew the three rear end cover screws and the **B** terminal nut, and remove the rear end cover.

W10189820

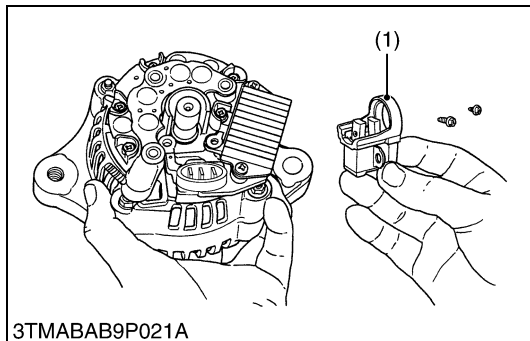
**Brush Holder**

1. Unscrew the two screws holding the brush holder (1), and remove the brush holder (1).

(1) Brush Holder

W10190540

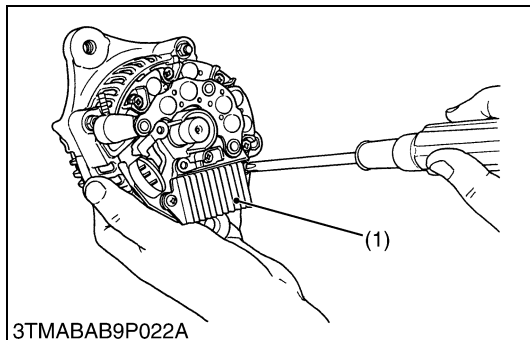
**IC Regulator**

1. Unscrew the three screws holding the IC regulator (1), and remove the IC regulator (1).

(1) IC Regulator

W10191230

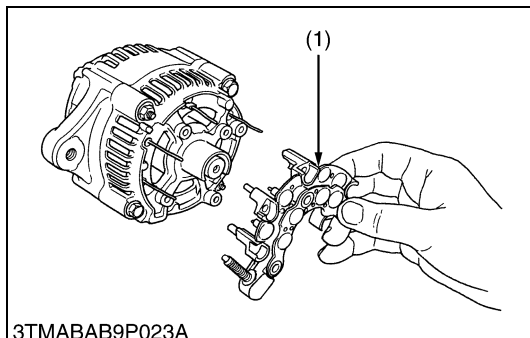
**Rectifier**

1. Remove the four screws holding the rectifier (1) and the stator lead wires.
2. Remove the rectifier (1).

(1) Rectifier

W10191920

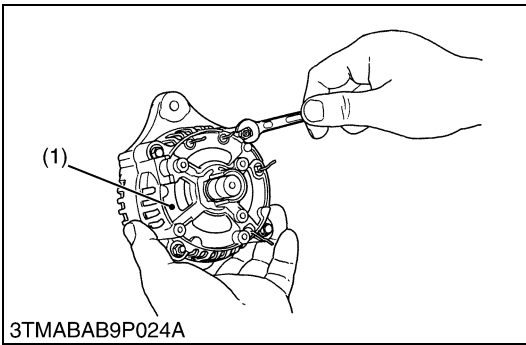

### Rear End Frame

1. Unscrew the two nuts and two screws holding the drive end frame and the rear end frame (1).
2. Remove the rear end frame (1).

(1) Rear End Frame

W10192740

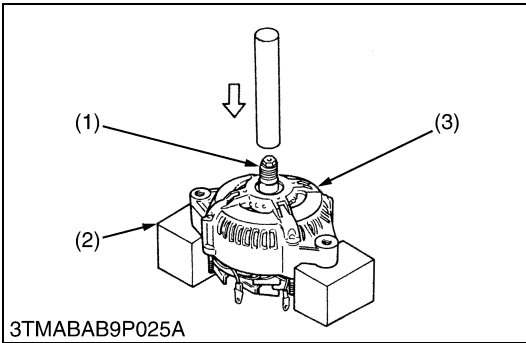

### Rotor

1. Press out the rotor (1) from drive end frame (3).

#### ■ IMPORTANT

- Take special care not to drop the rotor and damage the slip ring or fan, etc..

(1) Rotor  
(2) Block

(3) Drive End Frame

W10194380

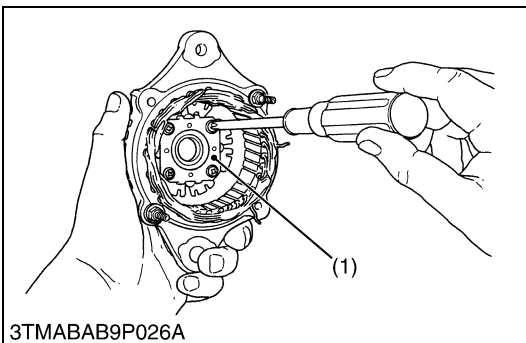

### Retainer Plate

1. Unscrew the four screws holding the retainer plate (1), and remove the retainer plate (1).

(1) Retainer Plate

W10195420

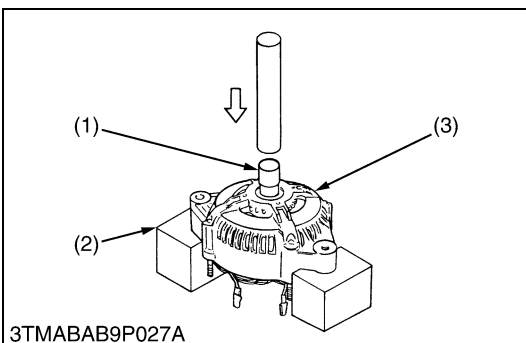

### Bearing on Drive End Side

1. Press out the bearing from drive end frame (3) with a press and jig (1).

(1) Jig  
(2) Block

(3) Drive End Frame

W10196110

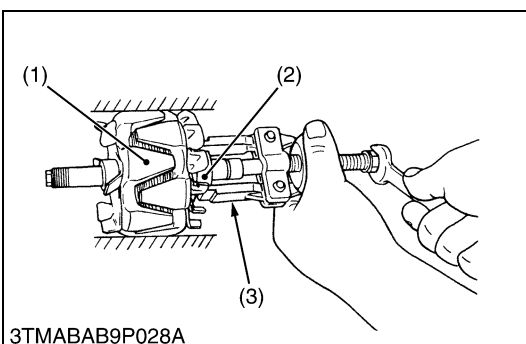

### Bearing at Slip Ring Side

1. Lightly secure the rotor (1) with a vise to prevent damage, and remove the bearing (2) with a puller (3).

(1) Rotor  
(2) Bearing

(3) Puller

W10197010

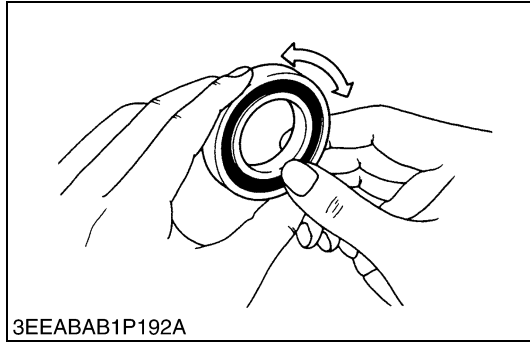
**(3) Servicing**

3EEABAB1P192A

**Bearing**

1. Check the bearing for smooth rotation.
2. If it does not rotate smoothly, replace it.

W10197900

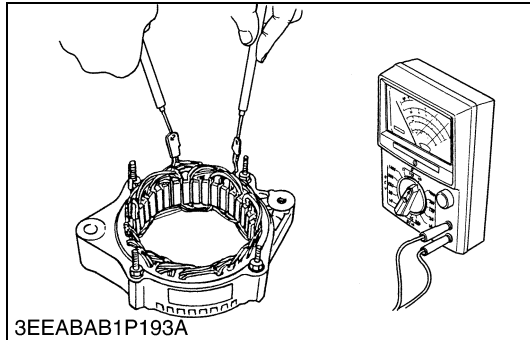

3EEABAB1P193A

**Stator**

1. Measure the resistance across each lead of the stator coil with an ohmmeter.
2. If the measurement is not within factory specification, replace it.
3. Check the continuity of each stator coil lead and core with an ohmmeter.
4. If infinity is not indicated, replace it.

Resistance	Factory spec.	Less than 1.0 $\Omega$
------------	---------------	------------------------

W10199640

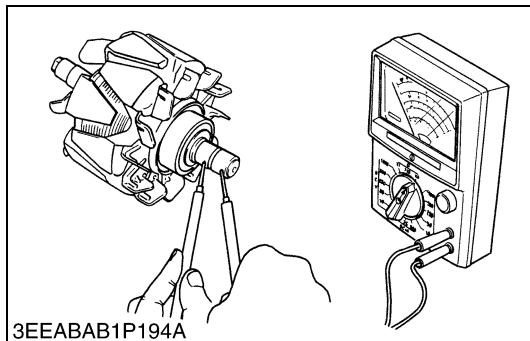

3EEABAB1P194A

**Rotor**

1. Measure the resistance across the slip rings with an ohmmeter.
2. If the resistance is not the factory specification, replace it.
3. Check the continuity of the slip ring and core with an ohmmeter.
4. If infinity is not indicated, replace it.

Resistance	Factory spec.	2.9 $\Omega$
------------	---------------	--------------

W10200940

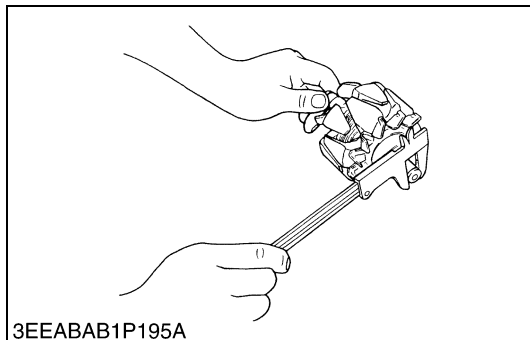

3EEABAB1P195A

**Slip Ring**

1. Check the slip ring for score.
2. If scored, correct with an emery paper or on a lathe.
3. Measure the O.D. of slip ring with vernier calipers.
4. If the measurement is less than the allowable limit, replace it.

Slip ring O.D.	Factory spec.	14.4 mm 0.567 in.
	Allowable limit	12.8 mm 0.504 in.

W10202080

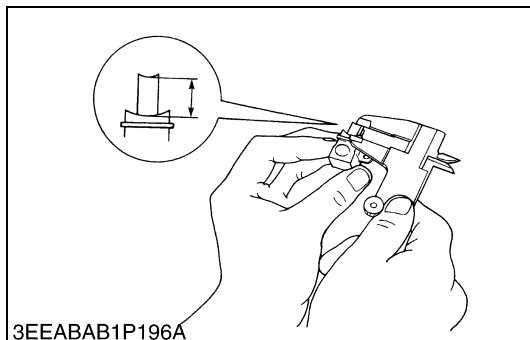

3EEABAB1P196A

**Brush Wear**

1. Measure the brush length with vernier calipers.
2. If the measurement is less than allowable limit, replace it.
3. Make sure that the brush moves smoothly.
4. If the brush is defective, replace it.

Brush length	Factory spec.	10.5 mm 0.413 in.
	Allowable limit	8.4 mm 0.331 in.

W10203290

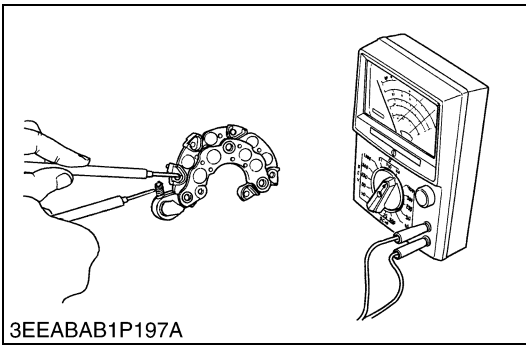

### Rectifier

1. Check the continuity of each diode of rectifier with an analog ohmmeter. Conduct the test in the (R × 1) setting.
2. The rectifier is normal if the diode in the rectifier conducts in one direction and does not conduct in the reverse direction.

#### ■ IMPORTANT

- Do not use a 500 V megger for measuring because it will destroy the rectifier.

#### ■ NOTE

- Do not use an auto digital multimeter. Because it's very hard to check the continuity of rectifier by using it.

W10204520

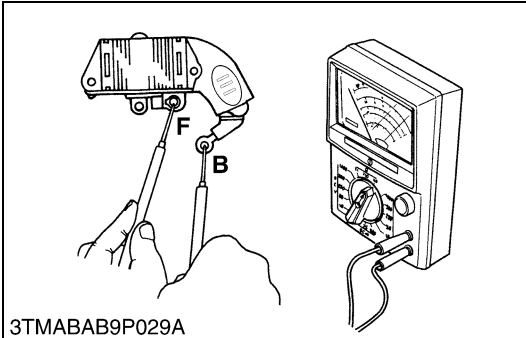

### IC Regulator

1. Check the continuity of the terminal **B** and the terminal **F** of IC regulator with an analog ohmmeter. Conduct the test in the (R × 1) setting.
2. The IC regulator is normal if the IC regulator conducts in one direction and does not conduct in the reverse direction.

#### ■ IMPORTANT

- Do not use a 500 V megger for measuring because it will destroy the IC regulator.

#### ■ NOTE

- Do not use an auto digital multimeter. Because it's very hard to check the continuity of IC regulator by using it.

W10206450



## [5] LIGHTING SYSTEM

### (1) Checking

#### (A) Combination Switch

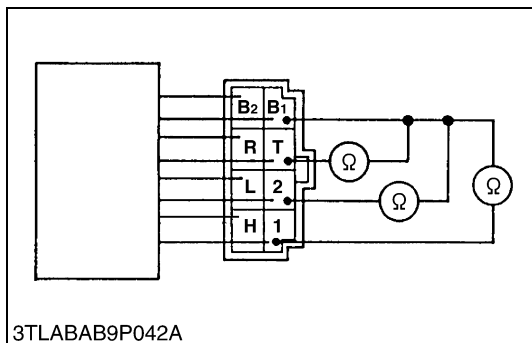
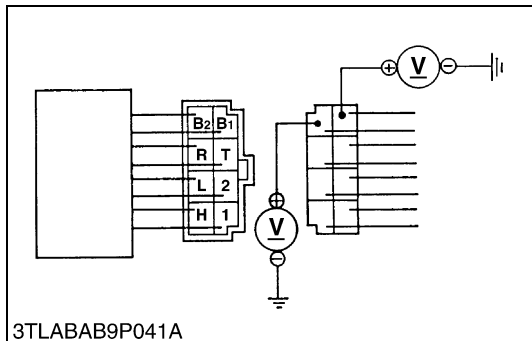

#### Remove the Combination Switch

1. Remove the panel cover, and disconnect the combination switch connector (2) after turning the main switch **OFF** position.
2. Perform the following checkings.

- (1) Combination Switch                      (2) Combination Switch Connector

W10207990

#### 1) Connector Voltage

1. Disconnect the **8P** connector from the combination switch.
2. Measure the voltage between the terminal **B1** and chassis, and between the terminal **B2** and chassis when the main switch is “**OFF**” position.
3. If the voltage differs from 0 V, the wiring harness is faulty.

Voltage	Main switch at “ <b>OFF</b> ” position	Terminal <b>B1</b> – Chassis	0 V
		Terminal <b>B2</b> – Chassis	

W1073019

#### 2) Light Switch Continuity when Setting Switch at OFF Position

1. Disconnect the combination switch connector.
2. Set the light switch to the **OFF** position.
3. Measure the resistance between the terminal **B1** and the terminal **T**, the terminal **1**, the terminal **2**.
4. If infinity is not indicated, the head light switch is faulty.

Resistance (Switch at <b>OFF</b> position)	Terminal <b>B1</b> – Terminal <b>T</b>	Infinity
	Terminal <b>B1</b> – Terminal <b>1</b>	
	Terminal <b>B1</b> – Terminal <b>2</b>	

W1042584

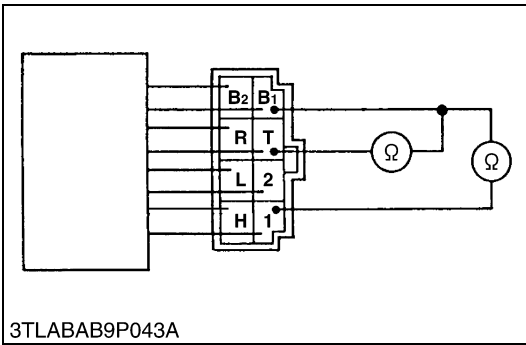

**3) Light Switch Continuity when Setting Switch at HIGH-BEAM Position**

1. Measure the resistance between the terminal **B1** and the terminal **T**, the terminal **1**.
2. If 0 Ω is not indicated, the head light switch is faulty.

Resistance (Switch at <b>HIGH-BEAM</b> position)	Terminal <b>B1</b> – Terminal <b>T</b>	0 Ω
	Terminal <b>B1</b> – Terminal <b>1</b>	

W1043473

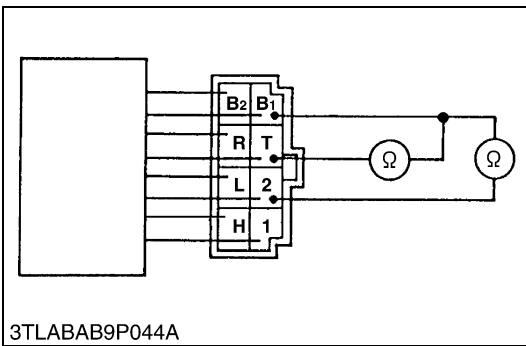

**4) Light Switch Continuity when Setting Switch at LOW-BEAM Position**

1. Measure the resistance between the terminal **B1** and the terminal **T**, the terminal **2**.
2. If 0 Ω is not indicated, the head light switch is faulty.

Resistance (Switch at <b>LOW-BEAM</b> position)	Terminal <b>B1</b> – Terminal <b>T</b>	0 Ω
	Terminal <b>B1</b> – Terminal <b>2</b>	

W1044119

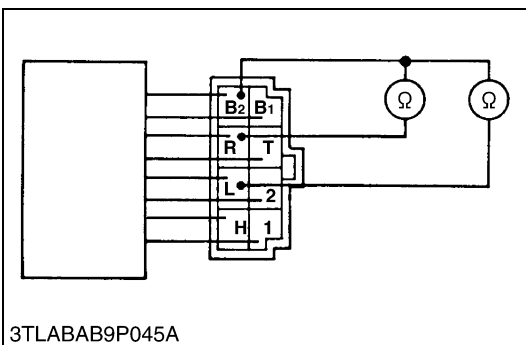

**5) Turn Signal Light Switch when Setting Switch Knob at OFF Position**

1. Set the turn signal light switch to the **OFF** position.
2. Measure the resistance between the terminal **B2** and the terminal **R**, the terminal **L**.
3. If infinity is not indicated, the turn signal light switch is faulty.

Resistance (Switch at <b>OFF</b> position)	Terminal <b>B2</b> – Terminal <b>R</b>	Infinity
	Terminal <b>B2</b> – Terminal <b>L</b>	

W1044501

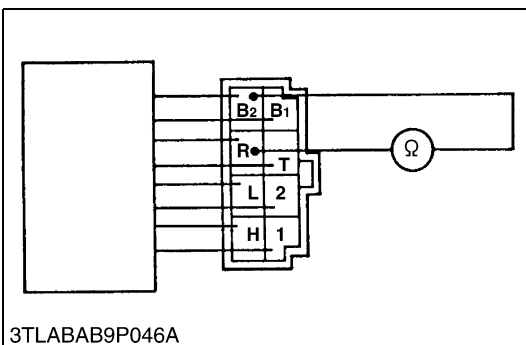

**6) Turn Signal Light Switch when Setting Switch Knob at R Position**

1. Set the turn signal light switch to the **R** position.
2. Measure the resistance between the terminal **B2** and the terminal **R**.
3. If 0 Ω is not indicated, the turn signal light switch is faulty.

Resistance (Switch at <b>R</b> position)	Terminal <b>B2</b> – Terminal <b>R</b>	0 Ω
--	--	-----

W1044955

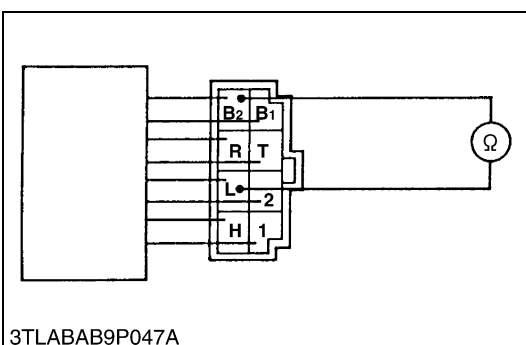

**7) Turn Signal Light Switch when Setting Switch Knob at L Position**

1. Set the turn signal light switch to the **L** position.
2. Measure the resistance between the terminal **B2** and the terminal **L**.
3. If 0 Ω is not indicated, the turn signal light switch is faulty.

Resistance (Switch at <b>L</b> position)	Terminal <b>B2</b> – Terminal <b>L</b>	0 Ω
--	--	-----

W1045932

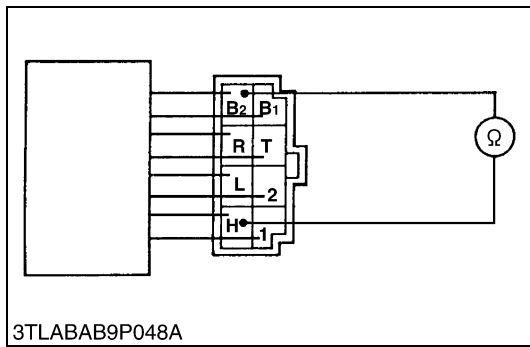

### 8) Horn Switch (If equipped)

1. Measure the resistance across the **B1** terminal to the **H** terminal.
2. If 0 ohm is not indicated, the horn switch is faulty.

Resistance (Horn switch is pushed)	<b>B1</b> terminal – H terminal	0 Ω
------------------------------------	---------------------------------	-----

W1074245

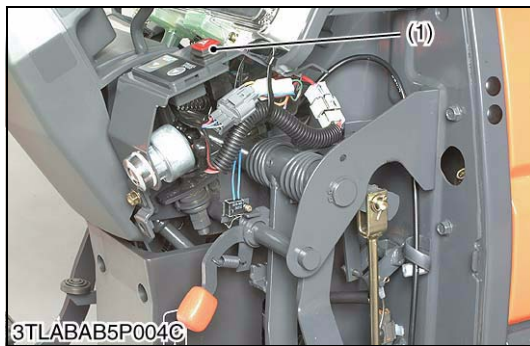

### Hazard Switch

1. Remove the meter panel and disconnect the **4P** connector from hazard switch (1) after disconnect the battery negative code.
2. Remove the hazard switch (1).
3. Perform the following checking.

(1) Hazard Switch

W1059839

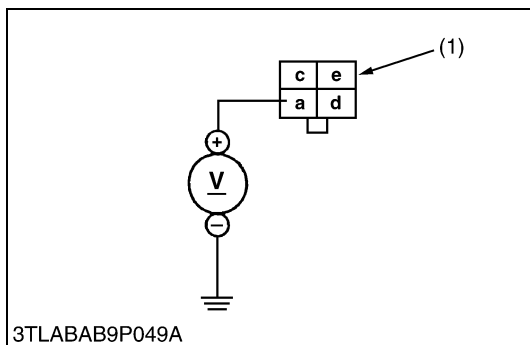

### 1) Connector Voltage

1. Connect the battery negative code, then measure the voltage across the terminal **a** and chassis.
2. If the voltage differ from the battery voltage, the wiring harness is faulty.

Voltage	Terminal <b>a</b> – Chassis	Approx. battery voltage
---------	-----------------------------	-------------------------

(1) **4P** Connector

W1060059

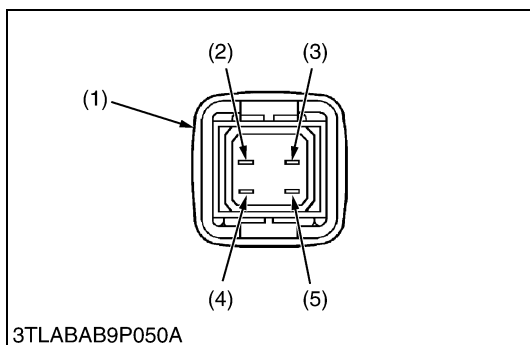

### 2) Hazard Switch Continuity

1. Measure the resistance with ohmmeter across the terminal **a** and terminal **c**, and across the terminal **d** and terminal **e**.
2. If the measurement is not following below, the hazard switch or the bulb are faulty.

Resistance (Switch at <b>OFF</b> )	Terminal <b>a</b> – Terminal <b>c</b>	Infinity
Resistance (Switch at <b>ON</b> )	Terminal <b>a</b> – Terminal <b>c</b>	0 Ω
Resistance (Bulb)	Terminal <b>d</b> – Terminal <b>e</b>	Approx. 13 Ω

(1) Hazard Switch Connector

(4) Terminal **c**

(2) Terminal **a**

(5) Terminal **e**

(3) Terminal **d**

W1060293



### Position Switch

1. Remove the meter panel and disconnect the connector from position switch (1) after disconnect the battery negative code.
2. Remove the position switch (1).
3. Perform the following checking.

(1) Position Switch

W1046485

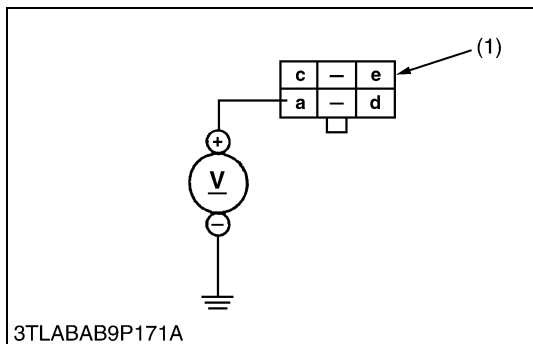

### 1) Connector Voltage

1. Connect the battery negative code, then measure the voltage between the terminal **a** and chassis.
2. If the voltage differ from the battery voltage, the wiring harness is faulty.

Voltage	Terminal <b>a</b> – Chassis	Approx. battery voltage
---------	-----------------------------	-------------------------

(1) Connector

W1046902

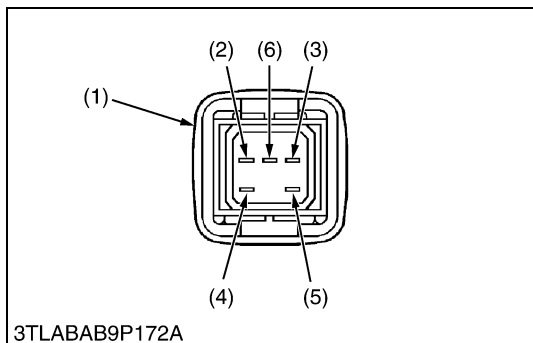

### 2) Position Switch Continuity

1. Measure the resistance with ohmmeter between the terminal **a** and terminal **c**, and between the terminal **d** and terminal **e**.
2. If the measurement is not following below, the position switch or the bulb are faulty.

Resistance (Switch at <b>OFF</b> )	Terminal <b>a</b> – Terminal <b>c</b>	Infinity
Resistance (Switch at <b>ON</b> )	Terminal <b>a</b> – Terminal <b>c</b>	0 Ω
Resistance (Bulb)	Terminal <b>d</b> – Terminal <b>e</b>	Approx. 13 Ω

(1) Position Switch Connector

(4) Terminal **c**

(2) Terminal **a**

(5) Terminal **e**

(3) Terminal **d**

(6) Terminal **b** (not used)

W1047271

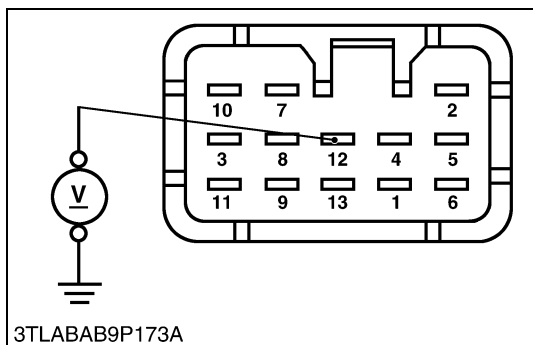

### Flasher Unit

1. Disconnect the connector from the flasher unit.
2. Turn the main switch at **ON** position.
3. Measure the voltage between the terminal **12** and chassis.
4. If the voltage differ from the battery voltage, the wiring harness is faulty.

Voltage	Terminal <b>12</b> – Chassis	Approx. battery voltage
---------	------------------------------	-------------------------

W1047788

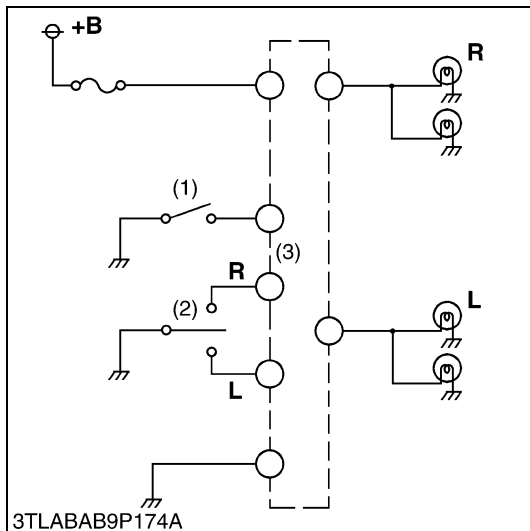

3TLABAB9P174A

**Flasher Unit Actuation Test**

1. Set the hazard switch to the **ON** position, and make sure the hazard light gives 60 to 85 flashes for a minute.
2. Set the main switch to the **ON** position and move the turn signal switch to the left. Make sure the left-hand light gives flashes. Then move the turn signal switch to the right and make sure the right-hand light gives flashes. Make sure the same actions as above result.
3. If both the hazard switch and the turn signal switch function but the above actions do not take place, replace the flasher unit with new one.

- (1) Hazard Switch  
 (2) Turn Signal Switch  
 (3) Flasher Unit

W1048275

**[6] WARNING LAMPS**

**(1) Checking**

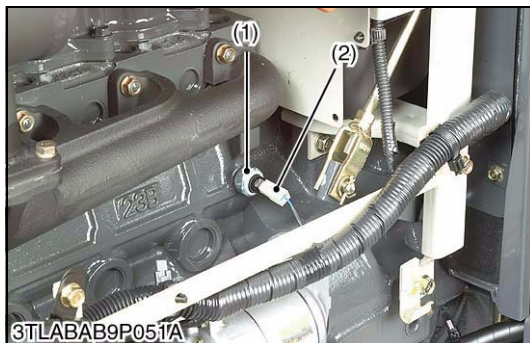

3TLABAB9P051A

**Engine Oil Pressure Switch Panel Board and Wiring Harness**

1. Disconnect the lead (2) from the engine oil pressure switch after turning the main switch **OFF**.
2. Turn the main switch **ON** and connect a jumper lead from the lead to the chassis.
3. If the engine oil pressure indicator lamp does not light, the panel circuit or the wiring harness is faulty.

- (1) Engine Oil Pressure Switch  
 (2) Switch Lead  
 (a) From Oil Pressure Lamp

W10259540

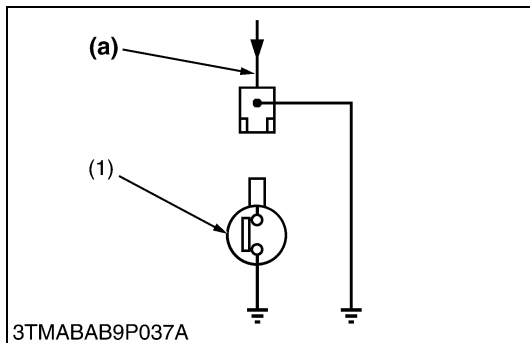

3TMABAB9P037A

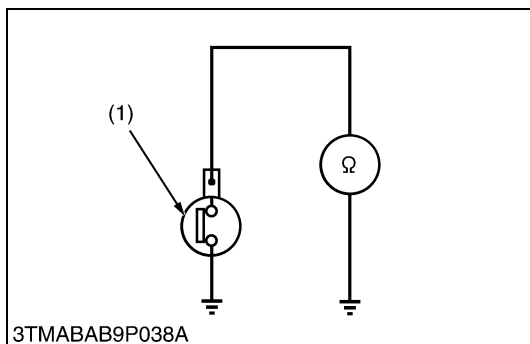

3TMABAB9P038A

**Engine Oil Pressure Switch Continuity**

1. Measure the resistance across the switch terminal and the chassis.
2. If 0 Ω is not indicated in the normal state, the switch is faulty.
3. If infinity is not indicated at pressure over 4.9 kPa (0.5 kgf/cm<sup>2</sup>, 7 psi), the switch is faulty.

Resistance (Switch terminal – Chassis)	In normal state	0 Ω
	At pressure over approx. 4.9 kPa (0.5 kgf/cm <sup>2</sup> , 7 psi)	Infinity

- (1) Engine Oil Pressure Switch

W10260840



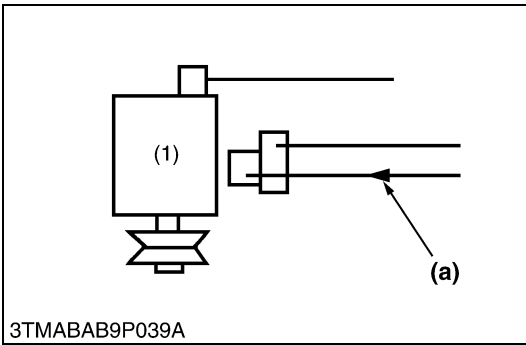

**Charging Circuit (Panel Board and Wiring Harness)**

1. Disconnect the **2P** connector from the alternator after turning the main switch **OFF**.
2. Turn the main switch **ON** and connect a jumper lead from the wiring harness connector terminal (**WR**) to the chassis.
3. If the charge lamp does not light, the panel board circuit, alternator, wiring harness, or fuse is fault.

(1) Alternator

(a) From Charge Lamp

W10262530

**[7] MONITOR LAMP**

**(1) Checking**

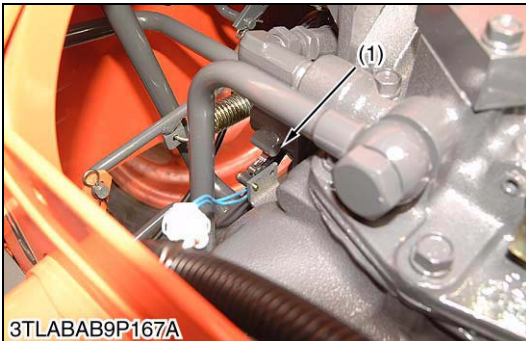

**Parking Brake Switch Continuity**

1. Disconnect the connector from the parking brake switch (1) after turning the main switch **OFF**.
2. Measure the resistance between the two terminals.
3. If infinity is not indicated, the switch is faulty.

Resistance (Across switch terminals)	In normal state	Infinity

(1) Parking Brake Switch

(2) Connector of Parking Brake Switch

W1026390

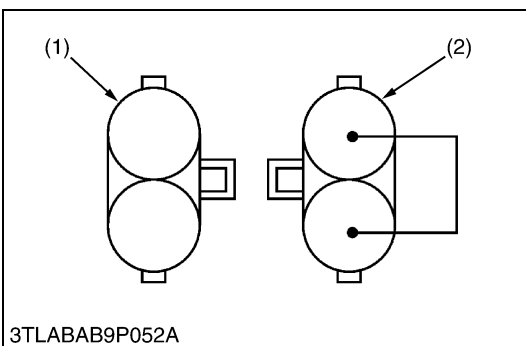
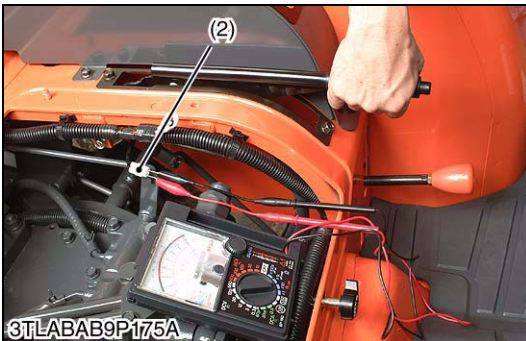

**Parking Brake Switch Panel and Wiring Harness**

1. Disconnect the connector from the parking brake switch after turning the main switch **OFF**.
2. Turn the main switch **ON** and connect a jumper lead between the connector terminals of wiring harness.
3. If the parking brake indicator lamp does not light, the panel circuit or wiring harness is faulty.

(1) Connector of Parking Brake Switch

(2) Connector of Wiring Harness

W1026754



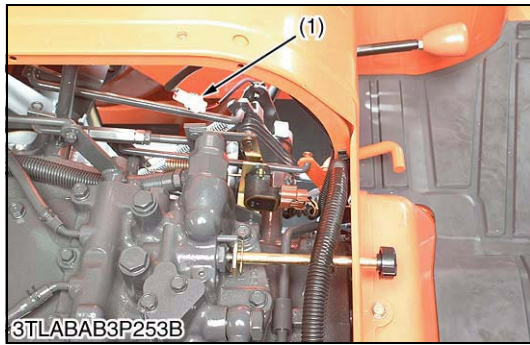

### Cruise Switch Continuity

1. Disconnect the connector (1) from the cruise switch after turning the main switch **OFF**.
2. Measure the resistance across the two terminals.
3. If infinity is not indicated, the switch is faulty.

Resistance (Across switch terminals)	In normal state	Infinity
--------------------------------------	-----------------	----------

(1) Cruise Switch Connector

W1075997

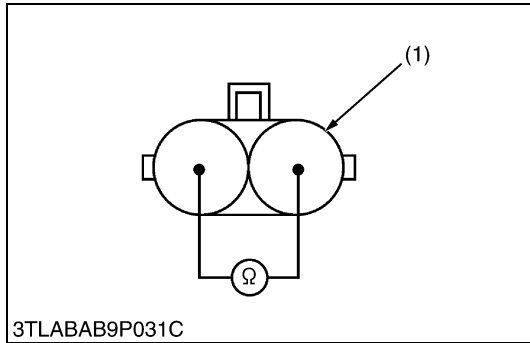

### Cruise Switch Panel and Wiring Harness

1. Disconnect the connector from the cruise switch after turning the main switch **OFF**.
2. Turn the main switch **ON** and connect a jumper lead between the connector terminals of wiring harness.
3. If the cruise indicator lamp does not light, the panel circuit or wiring harness is faulty.

(1) Connector of Cruise Switch

(2) Connector of Wiring Harness

W1076155

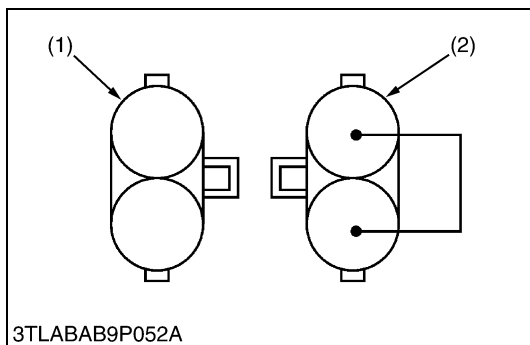

## [8] GAUGES

### (1) Checking

#### (A) Fuel Level Sensor

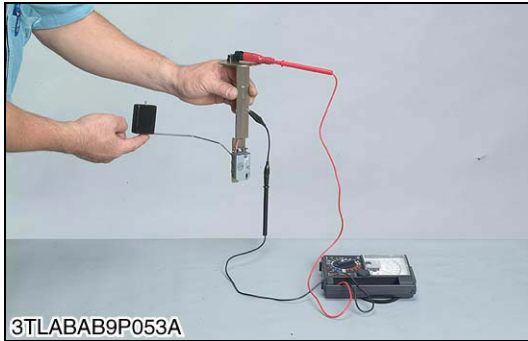

3TLABAB9P053A

#### Fuel Level Sensor

##### 1) Sensor Continuity

1. Remove the fuel level sensor from the fuel tank.
2. Measure the resistance across the sensor terminal and its body.
3. If the reference value are not indicated, the sensor is faulty.

Resistance (Sensor terminal – its body)	Reference value	Float at upper-most position	1 to 5 $\Omega$
		Float at lower-most position	103 to 117 $\Omega$

W10248650

#### (B) Coolant Temperature Sensor

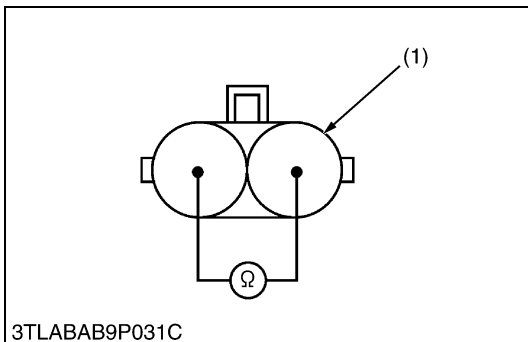

3TLABAB9P031C

#### Coolant Temperature Sensor Continuity

1. Measure the resistance across the sensor terminal and the chassis.
2. If the measurement is not indicated, the sensor is faulty.

Resistance (Sensor terminal – Chassis)	Factory spec.	Approx. 16 $\Omega$ at 120 °C (248 °F)
		Approx. 50 $\Omega$ at 80 °C (176 °F)
		Approx. 149 $\Omega$ at 50 °C (122 °F)

(1) Coolant Temperature Sensor

W1022725

# 10 CABIN

# MECHANISM

## CONTENTS

1. AIR CONDITIONER SYSTEM .....	10-M1
[1] OUTLINE OF AIR CONDITIONING SYSTEM .....	10-M1
(1) A/C Model .....	10-M1
(2) Heater Model .....	10-M3
[2] SYSTEM CONTROL.....	10-M4
(1) A/C Model .....	10-M4
(2) Heater Model .....	10-M5
[3] ELECTRICAL SYSTEM .....	10-M6
(1) Electrical Circuit .....	10-M6
(2) Air Conditioner Relay, Blower Relays and Compressor Relay .....	10-M7
(3) Air Conditioner Blower Switch.....	10-M8

# 1. AIR CONDITIONER SYSTEM

## [1] OUTLINE OF AIR CONDITIONING SYSTEM

### (1) A/C Model

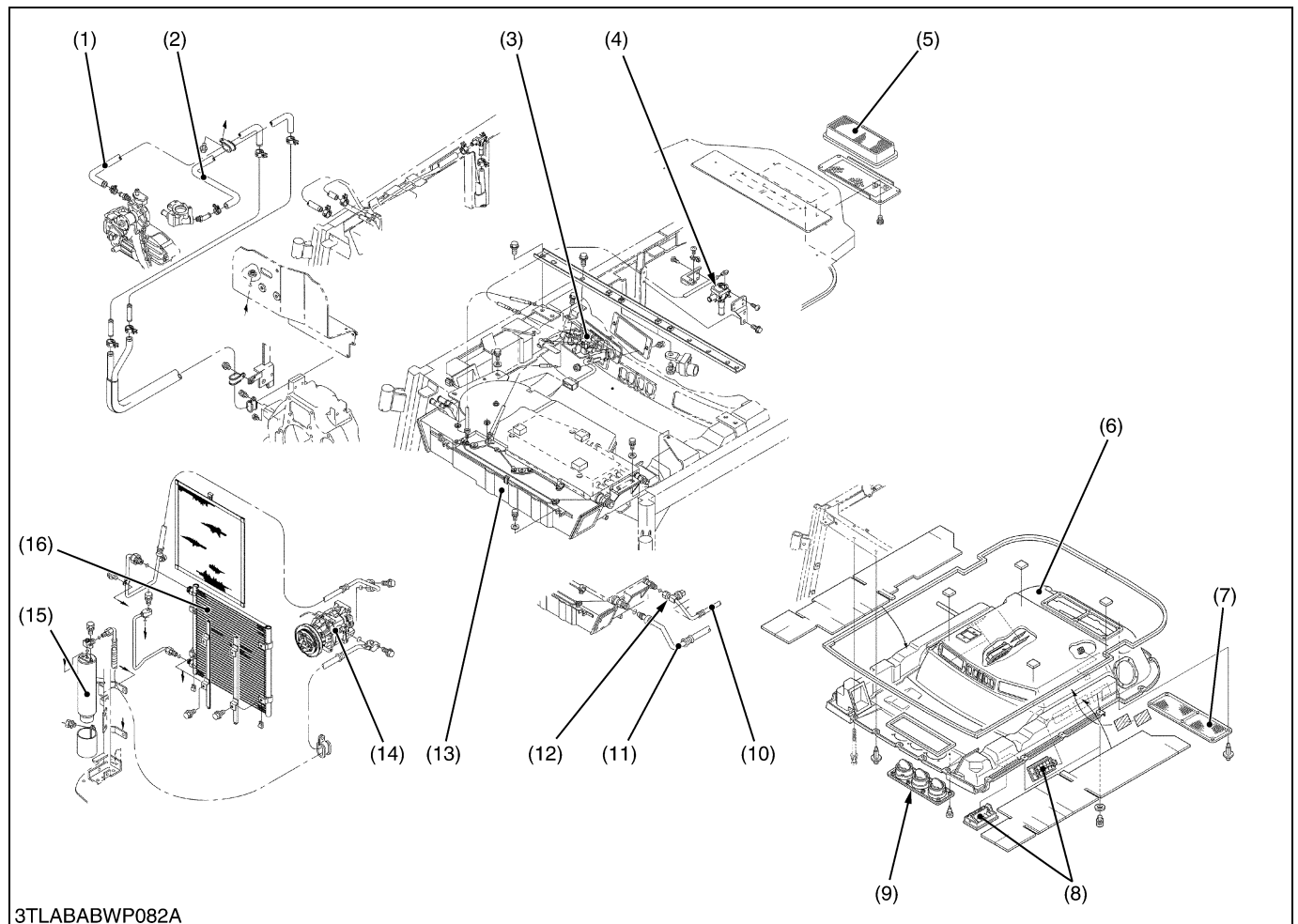

- |                            |                        |                         |                           |
|----------------------------|------------------------|-------------------------|---------------------------|
| (1) Heater Hose (Out Side) | (5) Outside Air Filter | (9) Front Air Outlet    | (13) Air Conditioner Unit |
| (2) Heater Hose (In Side)  | (6) Inner Roof         | (10) High Pressure Pipe | (14) Compressor           |
| (3) Control Panel          | (7) Inside Air Filter  | (11) Low Pressure Pipe  | (15) Receiver             |
| (4) Water Valve            | (8) Side Air Outlet    | (12) Pressure Switch    | (16) Condensor            |

The machine is equipped with a thin large-capacity air conditioner with outside air intake. Through the inside air filter (7) as well as the outside air filter (5), the inner roof (6) and reaches the air conditioner unit (13). The air is then cooled and defumidified by this unit.

The resulting air is heated to a comfortable level. In this way, the air being blown via the blow port can be kept at comfortable temperature and humidity.

The front air outlet (9) can be opened and closed using the center knob of each port. The side air outlet (8) are opened and closed using the mode lever on the control panel (3). With these ports open or closed, you can feel your head cool and your feet warm.

Capacity (Cooling)	Factory spec.	2.7 to 3.3 kW
Capacity (Warming)	Factory spec.	3.85 to 4.71 kW
Kinds of refrigerant (Charge amount)	Factory spec.	R134a 0.95 to 1.05 kg 2.09 to 2.31 lbs
Pressure sensor (Low)	Factory spec.	0.196 MPa 2.0 kgf/cm <sup>2</sup> 28.4 psi
Pressure sensor (High)	Factory spec.	3.14 MPa 32.0 kgf/cm <sup>2</sup> 455 psi

W1014918

#### ■ NOTE

- As for the mechanism and function of each component part, refer to Workshop Manual of "MECHANISM".

#### ■ Compressor Oil

The compressor oil dissolves in the refrigerant, circulates through the air-conditioning cycle, and functions to lubricate the compressor. But the conventional compressor oil for R12 doesn't dissolve in R134a, so it doesn't circulate through the cycle, and the lifespan of the compressor is considerably shortened.

It is still essential to ensure that the correct refrigerant oil is used. R12 systems were lubricated with mineral oil, which is totally unsuitable for R134a systems. The letter require PAG oil, which mixes very well with the refrigerant and provides ideal lubrication throughout the system.

Quantity (Total)	Brand Name
50 to 70 cm <sup>3</sup> 3.1 to 4.3 cu.in.	ND-OIL 8 <PAG* oil>

\*PAG : Polyalkyleneglycol (Synthetic oil)

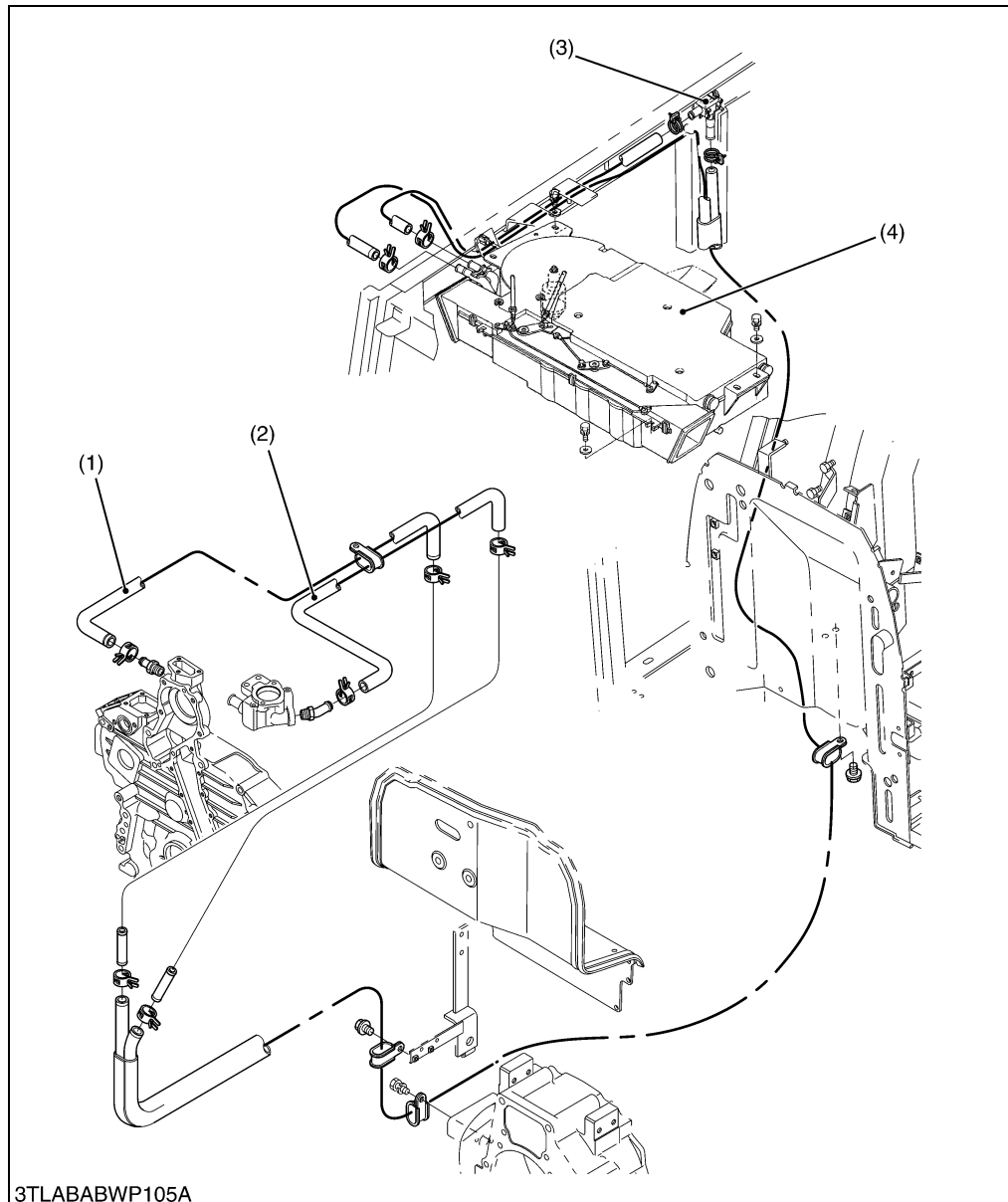

**(2) Heater Model**

- (1) Heater Hose (From Cabin)
- (2) Heater Hose (To Cabin)
- (3) Water Valve
- (4) Heater Unit

W1016479

## [2] SYSTEM CONTROL

### (1) A/C Model

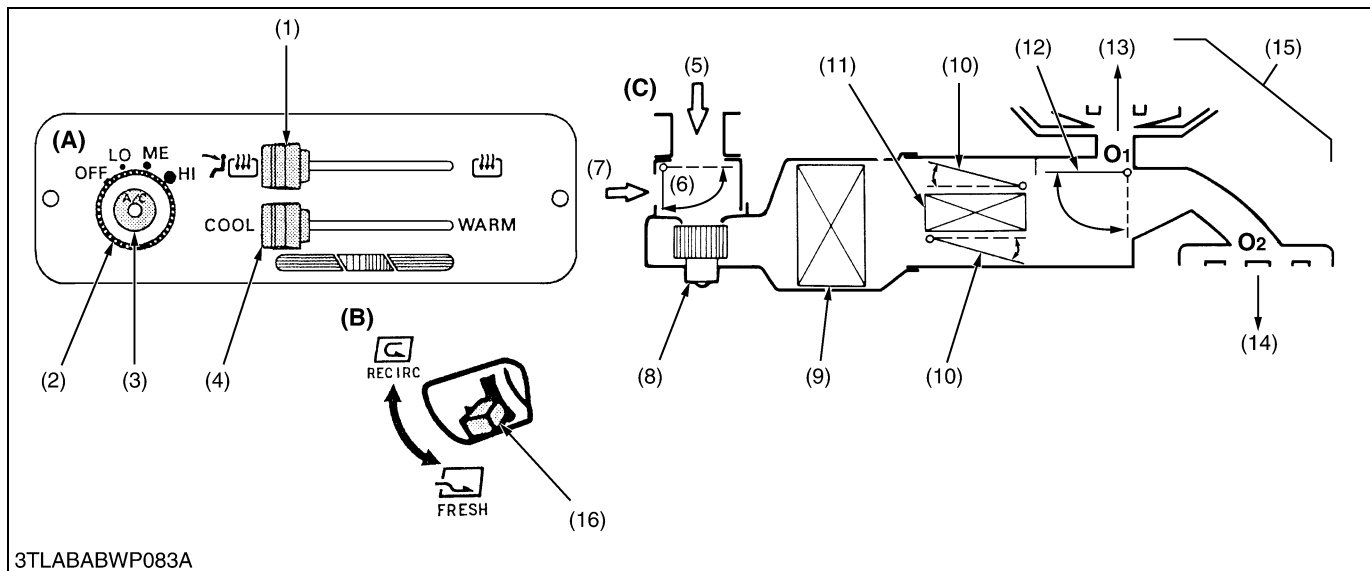

- |                               |  |  |  |
|-------------------------------|--|--|--|
| (1) Air Mode Lever            | (7) Recirculated Air                         | (12) Air Outlet Door D3<br>(Mode Door) | <b>(A) Control Plate</b>                         |
| (2) Blow Switch               | (8) Blower                                   | (13) DEFOGGER                          | <b>(B) Air Selection Lever</b>                   |
| (3) Air Conditioner Switch    | (9) Evaporator                               | (14) FACE                              | <b>(C) Block Diagram of Air Flow<br/>Passage</b> |
| (4) Temperature Control Lever | (10) Temperature Door D2<br>(Air Mixed Door) | (15) DEF and FACE                      | <b>O1 :Front air outlet</b>                      |
| (5) Fresh Air                 | (11) Heater Core                             | (16) Air Selection Lever               | <b>O2 :Side air outlet</b>                       |

#### 1) Selection of recirculated air (7) or fresh air (5) is done with door D1.

##### ■ RECIRC

By setting the air selection lever (16) in rear control panel to **RECIRC** position, door **D1** (6) shuts the fresh air inlet port. Air inside the cabin is recirculated.

##### ■ FRESH

By moving the air selection lever (16) to **FRESH** position, door **D1** opens the fresh air inlet port. Outside air comes into cabin.

#### 2) Temperature control of outlet air is done with door D2.

##### ■ COOL

By setting the temperature control lever (4) in control panel to **COOL** position, door **D2** (10) is moved to close water valve. The air flows to door **D3** (12) side without passing the heater core.

##### ■ WARM

By moving the temperature lever to **WARM** position door **D2** (10) is moved to open water valve. The air flows to door **D3** (12) side passing through the heater core.

#### 3) Outlet air flow is controlled by door D3.

Moving the air mode lever (1) opens and shuts door **D3** and establishes the air passage according to the lever position.

##### ■ DEF + FACE

By moving the mode lever to **DEF + FACE** position, the door **D3** (12) is moved to establish the air passages to outlets **O1** and **O2**. Air comes out from both outlets.

##### ■ DEF

Moving the mode lever to **DEF** position, door **D3** is moved to set up the air passage to outlet **O1**. Air comes out from outlet **O1**.

## (2) Heater Model

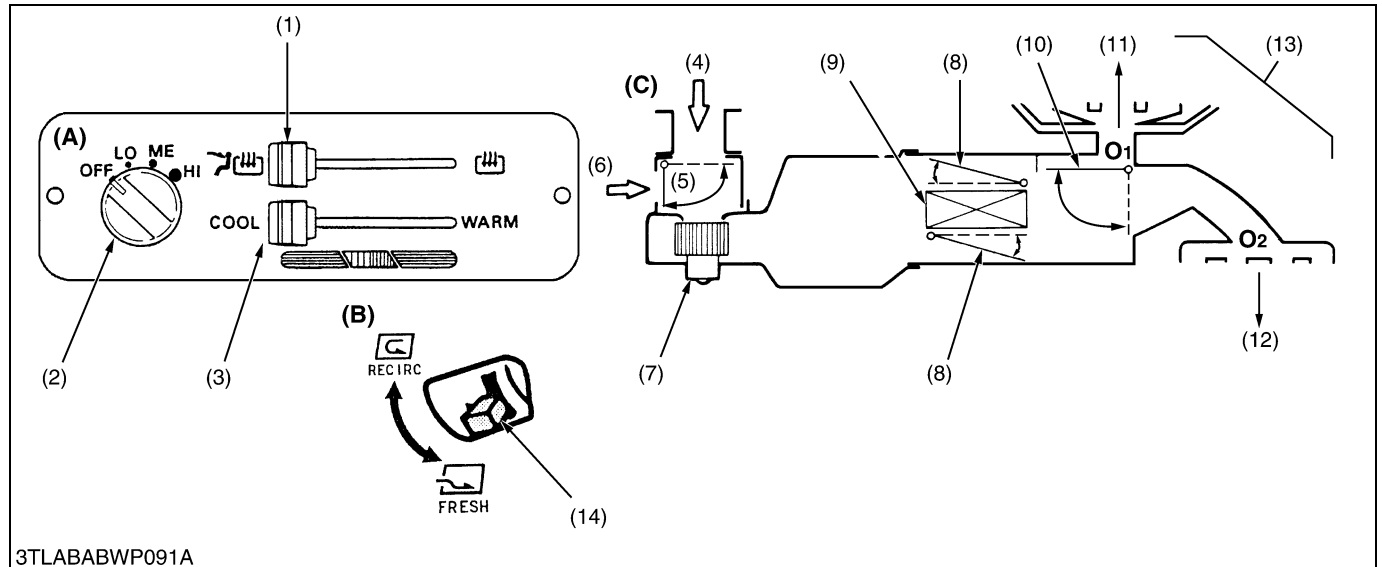

3TLABABWP091A

- |                               |   |                          |  |
|-------------------------------|---|--------------------------|--|
| (1) Air Mode Lever            | (7) Blower                                  | (11) DEFOGGER            | (A) Control Plate                        |
| (2) Blow Switch               | (8) Temperature Door D2<br>(Air Mixed Door) | (12) FACE                | (B) Air Selection Lever                  |
| (3) Temperature Control Lever | (9) Heater Core                             | (13) DEF and FACE        | (C) Block Diagram of Air Flow<br>Passage |
| (4) Fresh Air                 | (10) Air Outlet Door D3                     | (14) Air Selection Lever | O1 :Front air outlet                     |
| (5) Air Intake Door D1        |   |                          | O2 :Side air outlet                      |
| (6) Recirculated Air          |   |                          |  |

### 1) Selection of recirculated air (6) or fresh air (4) is done with door D1.

#### ■ RECIRC

By setting the air selection lever (14) in rear control panel to **RECIRC** position, door **D1** (5) shuts the flesh air inlet port. Air inside the cabin is recirculated.

#### ■ FRESH

By moving the air selection lever (14) to **FRESH** position, door **D1** opens the flesh air inlet port. Outside air comes into cabin.

### 2) Temperature control of outlet air is done with door D2.

#### ■ COOL

By setting the temperature control lever (3) in control panel to **COOL** position, door **D2** (8) is moved to close water valve. The air flows to door **D3** (10) side without passing the heater core.

#### ■ WARM

By moving the temperature lever to **WARM** position door **D2** (8) is moved to open water valve. The air flows to door **D3** (10) side passing through the heater core.

### 3) Outlet air flow is controlled by door D3.

Moving the air mode lever (1) opens and shuts door **D3** and establishes the air passage according to the lever position.

#### ■ DEF + FACE

By moving the mode lever to **DEF + FACE** position, the door **D3** (10) is moved to establish the air passages to outlets **O1** and **O2**. Air comes out from both outlets.

#### ■ DEF

Moving the mode lever to **DEF** position, door **D3** is moved to set up the air passage to outlet **O1**. Air comes out from outlet **O1**.

### [3] ELECTRICAL SYSTEM

#### (1) Electrical Circuit

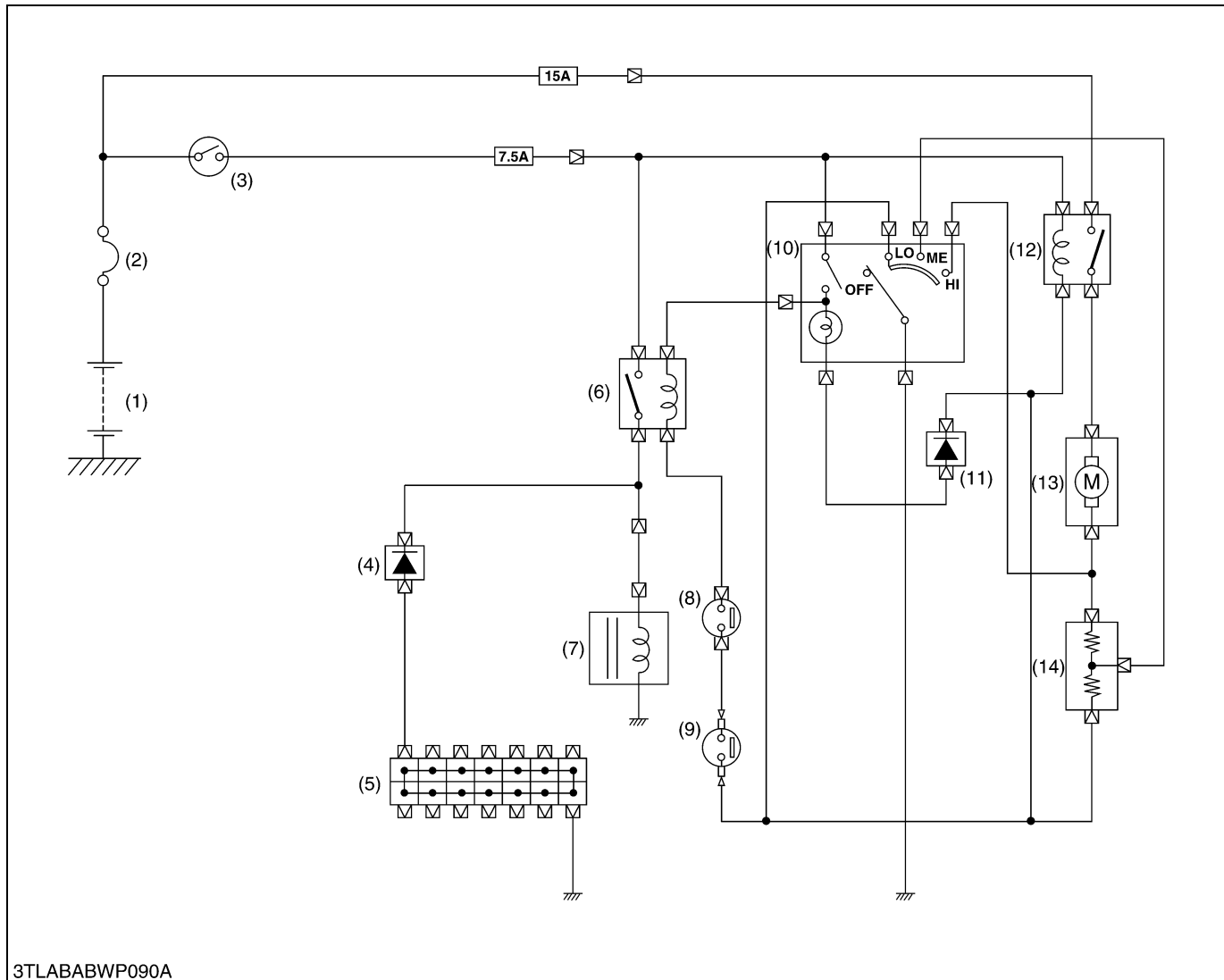

- |                    |                      |                        |                          |
|--------------------|----------------------|------------------------|--------------------------|
| (1) Battery        | (5) Joint Connector  | (9) Thermostat         | (12) A/C Blower Relay    |
| (2) Slow Blow Fuse | (6) Compressor Relay | (10) A/C Blower Switch | (13) A/C Blower Motor    |
| (3) Main Switch    | (7) Compressor       | (11) Diode             | (14) A/C Blower Resistor |
| (4) Diode          | (8) Pressure Switch  |                        |                          |

The process of magnetic clutch being engaged is shown below.

Main Switch (3) **ON** → A/C Switch (10) **ON** → Blower Switch (10) **ON** (Low, medium or High) → Compressor Relay Contact (6) → Thermo Switch (7) **ON** (the thermostat temperature is more than 4 °C (39.2 °F)) → Pressure Switch (8) **ON** (if refrigerant pressure is between 0.21 MPa (2.1 kgf/cm<sup>2</sup>, 30 psi) and 2.65 MPa (27 kgf/cm<sup>2</sup>, 384 psi) → Magnetic Clutch of Compressor (7) Engaged.

## (2) Air Conditioner Relay, Blower Relays and Compressor Relay

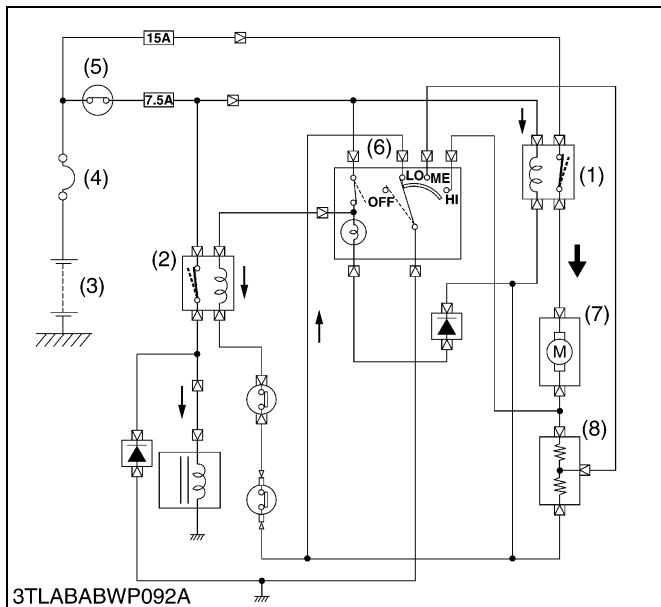
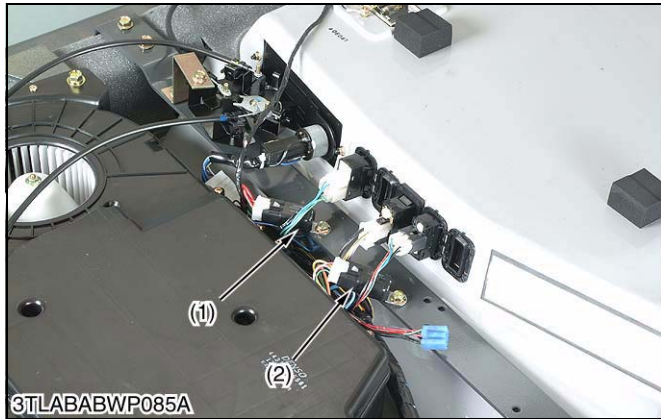

Remove the outer roof and the relays are visible at the ceiling center of the cabin : blower relay (1) and compressor relay (2). When the blower fan is adjusted for the air flow rate, the blower relay (1) is activated by a signal from the fan switch on the control panel.

Among the air conditioner components, current flows to the blower motor (7) and magnetic clutch. If all of these current were to be passed through the main switch (5) and supplied, the current would be too large for the main switch (5) so that there will be danger or burning out the main switch contact. If the current were to be passed directly from the battery (3), forgetting to turn off the blower motor (7) could result in a discharged battery (3).

To protect against such trouble, relays have been provided. These relays have been made so that when current flows through its coil, the contact close to supply the power from the battery (3). By employing these relays, the current flowing through the main switch (5) has been decreased as only a small current is required to actuate the relay. Thus there will be no danger of burning out the switch contact, and when the main switch (5) is opened, the relay contact will open at the same time. This action stops the current flow in the air conditioner circuit so that there will also be no chance of the battery discharging.

- |                      |                         |
|----------------------|-------------------------|
| (1) A/C Blower Relay | (5) Main Switch         |
| (2) Compressor Relay | (6) A/C Blower Switch   |
| (3) Battery          | (7) A/C Blower Motor    |
| (4) Slow Blow Fuse   | (8) A/C Blower Resistor |

W1013825

### (3) Air Conditioner Blower Switch

■ When Blower Switch is in • (Low), • (Medium) or ● (High) Position

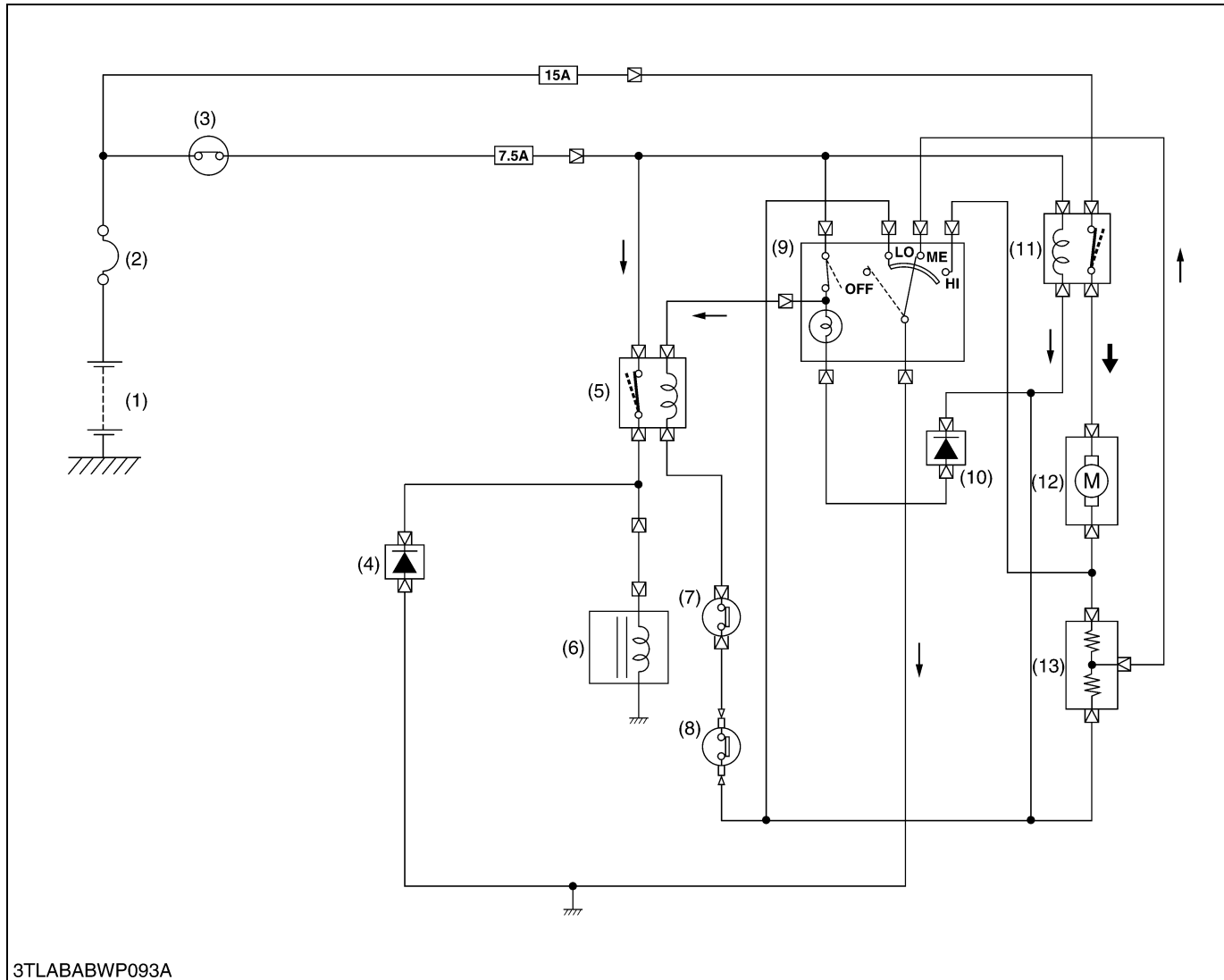

- |                    |                      |                        |                          |
|--------------------|----------------------|------------------------|--------------------------|
| (1) Battery        | (5) Joint Connector  | (9) Thermostat         | (12) A/C Blower Relay    |
| (2) Slow Blow Fuse | (6) Compressor Relay | (10) A/C Blower Switch | (13) A/C Blower Motor    |
| (3) Main Switch    | (7) Compressor       | (11) Diode             | (14) A/C Blower Resistor |
| (4) Diode          | (8) Pressure Switch  |                        |                          |

When the main switch (3) is turned **ON**, the current flows from battery (1) to A/C blower relay coil and A/C relay is turned **ON**. As the A/C relay is turned **ON**, the current from battery (1) flows to A/C blower switch through the A/C blower motor as follows.

#### “•” (Low) Position

Battery (1) → Slow Blow Fuse (2) → Main Switch (3) → Fuse (7.5 A) → A/C Blower Relay Contact (12) → Blower Motor (13) → Blower Resistor (14) → A/C Blower Switch (10) (**LO** Position) → Ground.

#### “•” (Medium) Position

Battery (1) → Slow Blow Fuse (2) → Main Switch (3) → Fuse → A/C Blower Relay Contact (12) → Blower Motor (13) → Blower Resistor (14) → A/C Blower Switch (10) (**ME** Position) → Ground.

#### “●” (High) Position

Battery (1) → Slow Blow Fuse (2) → Main Switch (3) → Fuse → A/C Blower Relay Contact (12) → A/C Blower Motor (13) → A/C Blower Switch (10) (**HI** Position) → Ground.



# SERVICING

## CONTENTS

1. TROUBLESHOOTING .....	10-S1
2. SERVICING SPECIFICATIONS .....	10-S6
3. TIGHTENING TORQUES .....	10-S7
4. PRECAUTIONS AT REPAIRING REFRIGERANT CYCLE .....	10-S8
[1] HANDLING OF SERVICE TOOLS.....	10-S9
(1) Manifold Gauge Set .....	10-S9
(2) Refrigerant Charging Hose .....	10-S10
(3) Vacuum Pump Adaptor .....	10-S11
(4) Electric Gas Leak Tester.....	10-S11
(5) Can Tap Valve .....	10-S11
(6) T-joint .....	10-S12
(7) R134a Refrigerant Recovery and Recycling Machine .....	10-S12
5. CHECKING AND CHARGING REFRIGERANT CYCLE.....	10-S13
[1] CHECKING WITH MANIFOLD GAUGE .....	10-S13
[2] DISCHARGING, EVACUATING AND CHARGING .....	10-S17
(1) Discharging the System .....	10-S17
(2) Evacuating the System .....	10-S17
(3) Charging the System .....	10-S19
(4) Checking Charge Refrigerant Amount .....	10-S21
6. CHECKING, DISASSEMBLING AND SERVICING.....	10-S22
[1] SEPARATING CABIN FROM TRACTOR BODY.....	10-S22
[2] COMPRESSOR .....	10-S28
(1) Checking.....	10-S28
(2) Disassembling and Assembling .....	10-S28
(3) Servicing .....	10-S31
[3] AIR CONDITIONER SYSTEM AND FRONT WINDSHIELD WIPER.....	10-S31
(1) Checking.....	10-S31
(2) Disassembling and Assembling .....	10-S38
(3) Servicing .....	10-S49
[4] LIGHTING SYSTEM .....	10-S49
(1) Checking.....	10-S49
[5] OTHERS .....	10-S50
(1) Disassembling and Assembling .....	10-S50

# 1. TROUBLESHOOTING

## COMPRESSOR

Symptom	Probable Cause	Solution	Reference Page
<b>Noisy (Compressor ON)</b>	<ul style="list-style-type: none"> <li>Bearing of compressor worn or damaged</li> <li>Valves in compressor damaged</li> <li>Belt slipping</li> <li>Compressor bracket mounting screws loosen</li> <li>Piping resonant</li> </ul>	Replace	10-S29
		Replace	10-S29
<b>(Compressor OFF)</b>	<ul style="list-style-type: none"> <li>Blower defective</li> <li>Bearings of magnetic clutch, idle pulley or crank pulley worn or damaged</li> </ul>	Adjust or replace	G-29
		Tighten	–
		Tighten or add clamp	–
		Repair or replace	10-S33
		Replace	–

W1013580

## AIR CONDITIONING SYSTEM

<b>Does Not Cool (No Air Flow)</b>	<ul style="list-style-type: none"> <li>Fuse blown</li> <li>A/C main relay defective</li> <li>Blower relay defective</li> <li>Blower motor defective</li> <li>Blower switch defective</li> <li>Wiring harness disconnected or improperly connected</li> </ul>	Replace	G-36
		Repair or replace	10-S31
<b>(Compressor Does Not Rotate)</b>	<ul style="list-style-type: none"> <li>Fuse blown</li> <li>Magnetic clutch defective</li> <li>A/C switch defective</li> <li>Pressure switch defective</li> <li>Belt slipping</li> </ul>	Replace	10-S31
		Replace	10-S33
<b>(Others)</b>	<ul style="list-style-type: none"> <li>Insufficient refrigerant</li> <li>Expansion valve defective</li> <li>Compressor defective</li> </ul>	Replace	10-S32
		Repair	–
		Check with manifold gauge	10-S13
		Replace	–
		Replace	10-S29
<b>Insufficient Cooling (Insufficient Air Flow)</b>	<ul style="list-style-type: none"> <li>Air filter clogged</li> <li>Evaporator frosted</li> </ul>	Clean or replace	G-30
		Clean or replace	10-S41
<b>(Many Bubbles in Sight Glass)</b>	<ul style="list-style-type: none"> <li>Blower motor defective</li> <li>Insufficient refrigerant</li> </ul>	Replace	10-S33
		Check with manifold gauge	10-S13
<b>(No Bubbles in Sight Glass)</b>	<ul style="list-style-type: none"> <li>Gas leaking from some place in refrigerating cycle</li> <li>Air mixed in</li> </ul>	Repair and charge refrigerant	10-S11
		Check with manifold gauge	10-S14
	<ul style="list-style-type: none"> <li>Too much refrigerant</li> </ul>	Check with manifold gauge	10-S14

W1013718

**AIR CONDITIONING SYSTEM (Continued)**

Symptom	Probable Cause	Solution	Reference Page
<b>Insufficient Cooling (Compressor Does Not Rotate Properly)</b>  <b>(Others)</b>	• Belt slipping	Adjust or replace	G-29
	• Magnetic clutch defective	Repair or replace	10-S28
	• Compressor defective	Replace	10-S29
	• Thermostat defective	Replace	–
	• Water valve defective	Replace	–
	• Condenser fin clogged with dust	Clean	G-30
	• Expansion valve defective	Replace	–
<b>Insufficient Heating</b>	• Water valve defective	Replace	–
	• Air mix door malfunctioning	Adjust control cable	10-S40, S46
	• Insufficient coolant	Replenish	G-7, 8

W1013580

**AIR CONDITIONING SYSTEM (Continued)**

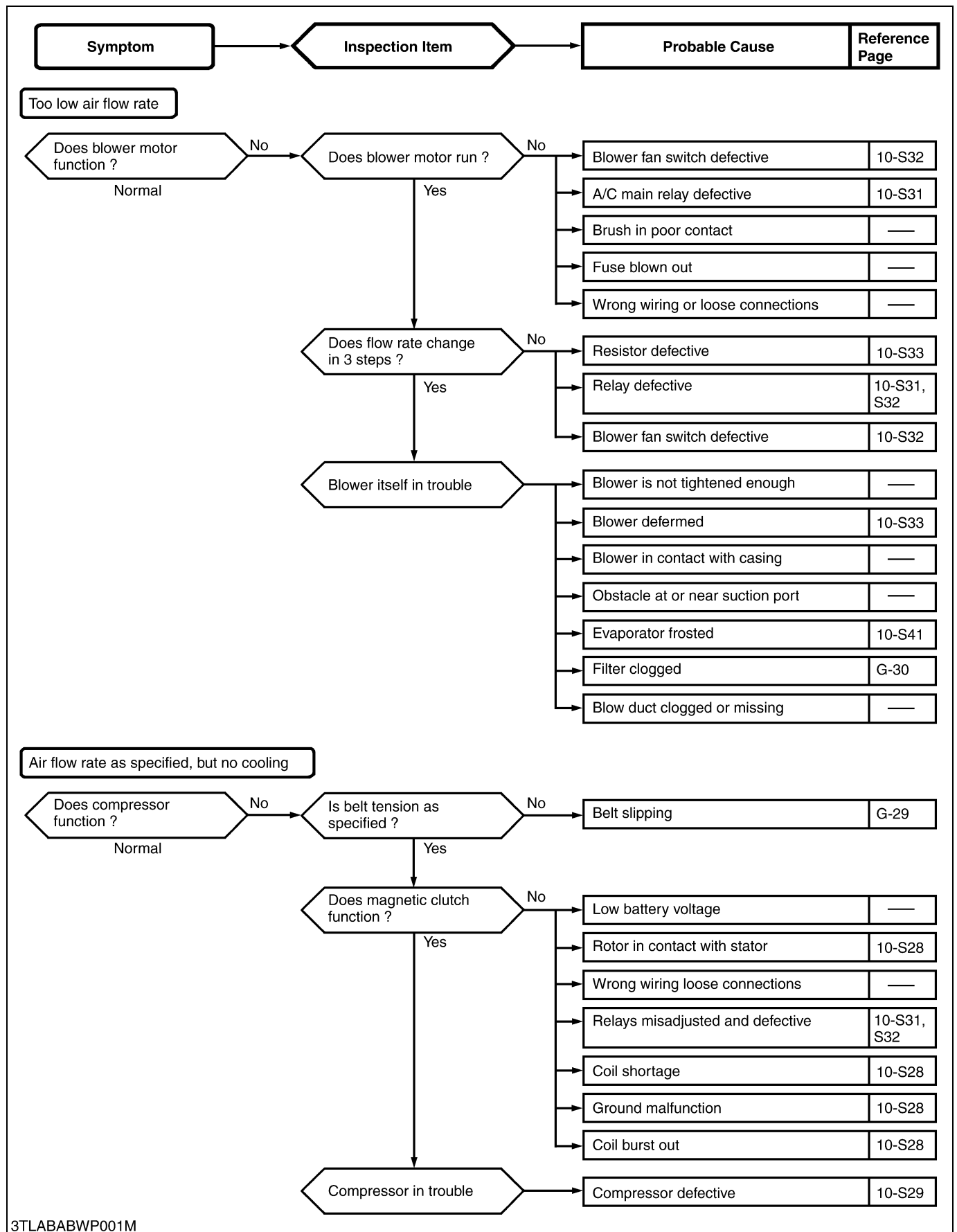

3TLABABWP001M

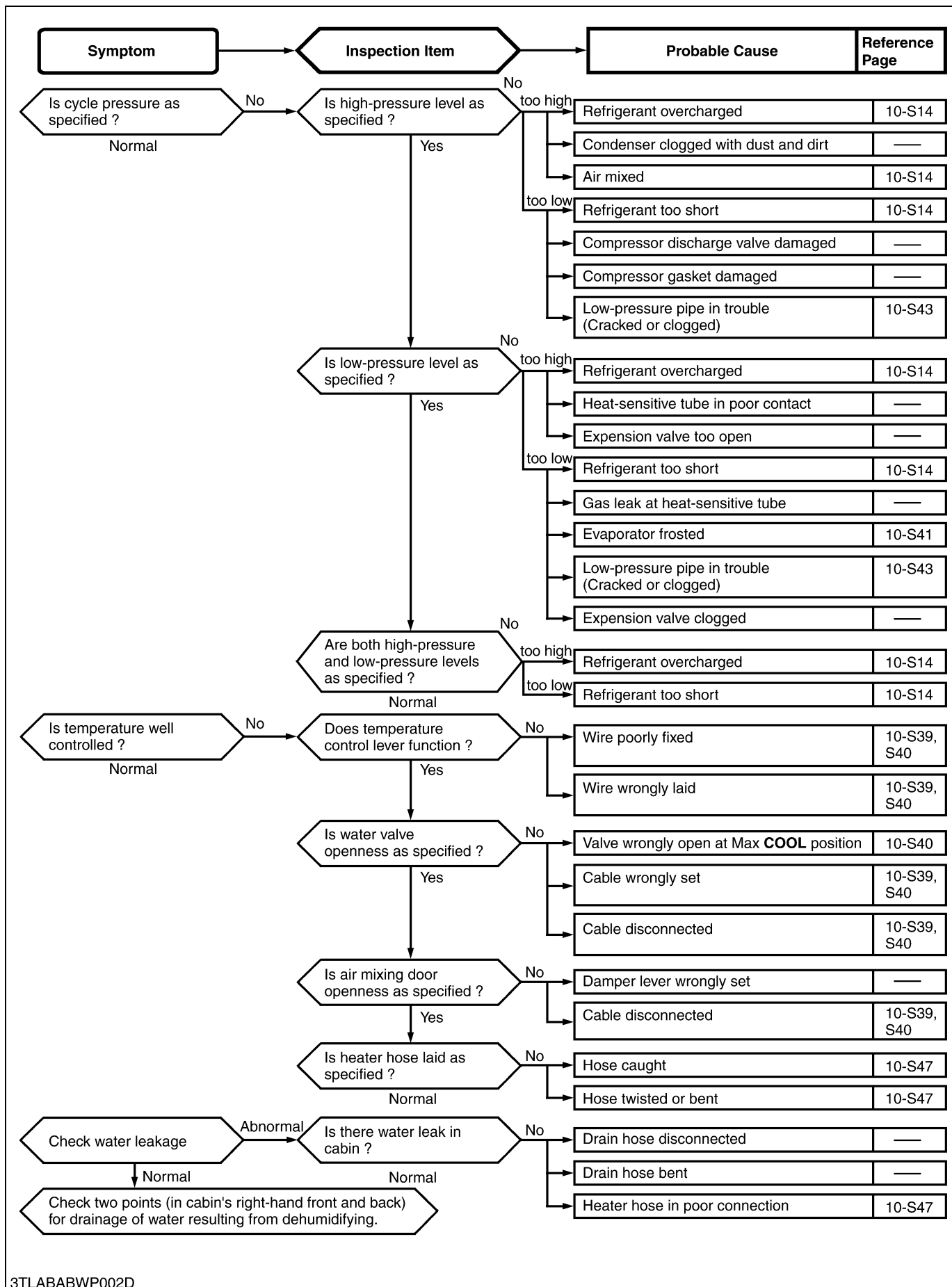

3TLABABWP002D

**WINDSHIELD WIPER**

Symptom	Probable Cause	Solution	Reference Page
<b>Windshield Wiper Does Not Operate</b>	<ul style="list-style-type: none"> <li>• Wiring defective</li> <li>• Fuse blown (Short-circuit, burnt component inside motor or other part for operation)</li> <li>• Wiper motor defective (Broken armature, worn motor brush or seized motor shaft)</li> <li>• Wiper switch defective</li> <li>• Foreign material interrupts movement of link mechanism</li> <li>• Wiper arm seized or rusted</li> </ul>	Check and repair Correct cause and replace Replace  Replace Repair  Lubricate or replace	– G-36  10-S37  10-S36 10-S39, S40 10-S42
<b>Windshield Wiper Operating Speed Is Too Low</b>	<ul style="list-style-type: none"> <li>• Wiper motor defective (Short-circuit of motor armature, worn motor brush or seized motor shaft)</li> <li>• Low battery voltage</li> <li>• Humming occurs on motor in arm operating cycle due to seized arm shaft</li> <li>• Wiper switch contact improper</li> </ul>	Replace  Recharge or replace Lubricate or replace  Replace	10-S42  G-25 – 10-S36
<b>Windshield Wiper Does Not Stop Correctly</b>	<ul style="list-style-type: none"> <li>• Wiper motor defective (Contaminated auto-return contacts or improper contact due to foreign matter)</li> </ul>	Replace	10-S42

W1066515

**WASHER MOTOR**

<b>Washer Motor Does Not Operate</b>	<ul style="list-style-type: none"> <li>• Fuse blown</li> <li>• Washer switch defective</li> <li>• Washer motor defective</li> <li>• Wiring defective</li> </ul>	Correct cause and replace Replace Replace Repair	– 10-S36 – –
<b>Washer Motor Operate but Washer Fluid Is Not Ejected</b>	<ul style="list-style-type: none"> <li>• No washer fluid</li> <li>• Clogged washer nozzle</li> </ul>	Replenish Clean or replace	– –

W1011118



## 2. SERVICING SPECIFICATIONS

Item		Factory Specification	Allowable Limit
Air-gap of A/C Compressor Magnet Clutch	Air-gap	0.20 to 0.45 mm 0.008 to 0.018 in.	–
Refrigerating Cycle (Refrigerating Cycle is Normal Operating) Condition <ul style="list-style-type: none"> <li>• Engine Speed : Approx. 1500 min<sup>-1</sup> (rpm)</li> <li>• Ambient Temperature : 30 to 35 °C 86 to 95 °F</li> <li>• Blower Switch : <b>PURGE</b> Position</li> </ul>	Pressure ( <b>LO</b> Pressure Side)	0.15 to 0.20 MPa 1.5 to 2.0 kgf/cm <sup>2</sup> 21 to 28 psi	–
	Pressure ( <b>HI</b> Pressure Side)	1.27 to 1.66 MPa 13 to 17 kgf/cm <sup>2</sup> 185 to 242 psi	–
Pressure Switch (Dual Type) (When pressure switch is turned <b>OFF</b> )	Setting Pressure ( <b>LO</b> Pressure Side)	Less than approx. 0.196 MPa 2.0 kgf/cm <sup>2</sup> 28.4 psi	–
	Setting Pressure ( <b>HI</b> Pressure Side)	More than approx. 3.14 MPa 32 kgf/cm <sup>2</sup> 455 psi	–
Air Conditioner Drive Belt	Tension	10 to 12 mm (0.39 to 0.47 in.) deflection at 98 N (10 kgf, 22 lbs) of force	–
Proper Clutch Pedal	Free Travel	35 to 45 mm 1.38 to 1.77 in.	–
Proper Brake Pedal	Free Travel	40 to 45 mm 1.57 to 1.77 in.	–
Shift Rod	Length	Approx. 275 mm 10.8 in.	–
Hydraulic Control Rod Position and Draft Rod	Length	Approx. 362 mm 14.25 in.	–

W1013874

### 3. TIGHTENING TORQUES

Tightening torques of screws, bolts and nuts on the table below are especially specified.  
(For general use screws, bolts and nuts : See page G-10.)

Item	N·m	kgf·m	ft-lbs
Compressor mounting screws	24.5 to 29.4	2.5 to 3.0	18.1 to 21.7
Muffler mounting screw	31.4 to 37.2	3.2 to 3.8	23.1 to 27.5
Cabin mounting bolt and nut	124 to 147	12.6 to 15.0	91.1 to 108
High pressure pipe and low pressure pipe mounting screw	7.9 to 11.8	0.81 to 1.20	5.8 to 8.7
Clutch mounting screw	10.8 to 16.2	1.10 to 1.65	8.0 to 11.9
A/C unit mounting screws (M6)	3.9 to 6.9	0.4 to 0.7	2.89 to 5.06
A/C unit mounting screws (M8)	9.8 to 15.7	1.0 to 1.6	7.23 to 11.6
Low pressure pipe (cooler pipe (suction)) retaining nut	29.4 to 34.3	3.0 to 3.5	21.7 to 25.3
High pressure pipe (cooler pipe (liquid)) retaining nut	11.8 to 14.7	1.2 to 1.5	8.7 to 10.8
Wiper arm mounting nut (Front)	6.37 to 9.32	0.65 to 0.95	4.7 to 6.9
Wiper motor mounting nut (Front)	2.5 to 3.4	0.25 to 0.35	1.9 to 2.5
Wiper arm mounting nut (Rear)	4.9 to 6.9	0.50 to 0.70	3.61 to 5.09
Wiper motor mounting bolt (Rear)	4.90 to 5.88	0.50 to 0.60	3.61 to 4.30
High pressure pipe 1 mounting screw (compressor side)	7.8 to 11.8	0.81 to 1.20	5.8 to 8.7
High pressure retaining nut (condenser side)	19.6 to 24.5	2.0 to 2.5	14.5 to 18.1
High pressure pipe 2 retaining nut	11.8 to 14.7	1.2 to 1.5	8.7 to 10.8
Low pressure pipe mounting screw (compressor side)	7.9 to 11.8	0.81 to 1.20	5.8 to 8.7
Low pressure pipe retaining nut	29.4 to 34.3	3.0 to 3.5	21.7 to 25.3
Heater unit mounting screw (M6)	3.92 to 6.86	0.40 to 0.70	2.89 to 5.06
Heater unit mounting screw (M8)	9.80 to 11.68	1.00 to 1.19	7.23 to 8.60

W1012736

## 4. PRECAUTIONS AT REPAIRING REFRIGERANT CYCLE

When checking or repairing the air conditioning system, the following precautions and rules must be observed. And it is of first importance that no other personnel than a well-trained serviceman should be allowed to handle the refrigerant.

### CAUTION

- Since direct contact of the liquid refrigerant with your skin will cause frostbite, always be careful when handling the refrigerant. Always wear goggles to protect your eyes when working around the system.
- The refrigerant service container has a safe strength. However, if handled incorrectly, it will explode. Therefore, always follow the instructions on the label. In particular, never heat the refrigerant container above 40 °C (104 °F) or drop it from a high height.
- Do not steam clean on the system, especially condenser since excessively high pressure will build up in the system, resulting in explosion of the system.
- If you improperly connect the hose between the service valve of compressor and gauge manifold, or incorrectly handle the valves, the refrigerant service container or charging hose will explode. When connecting the hose or handling the valve, be sure to check the high pressure side or low pressure side.
- In case the refrigerant is charged while the compressor is operated, do not open the high pressure valve of the gauge manifold.
- Beware of the toxicity of the gas. The gas is harmless and nontoxic in its original state, however it produces a toxic substance when it comes in contact with high temperature parts and decomposes.
- Do not heat the service can unless necessary. When it has to be heated, use warm water of 40 °C (104 °F) or lower. Do not heat using boiling water.

### ■ IMPORTANT

- If the refrigerant, O-rings, etc. for R12 are used in the R134a air conditioner system, problems such as refrigerant leakage or cloudiness in the sight glass may occur. Therefore, in order to prevent charging of refrigerant or erroneous connections, the shapes of the piping joint as well as the shapes of the service valve and the service tools have been changed.
- Always keep the working place clean and dry and free from dirt and dust. Wipe off water from the line fittings with a clean cloth before disconnecting.
- Use only for R134a refrigerant service tool.
- Use for R134a refrigerant recovery and recycling machine when discharging the refrigerant.
- Before attaching the charging hose to the can tap valve of the refrigerant container, check each packing for clogging.
- When disconnecting the charging hose from the charging valve of compressor and receiver, remove it as quick as possible so that gas leakage can be minimized.
- Be sure to charge the specified amount of refrigerant, but not excessively. Over-charging of the refrigerant in particular may cause insufficient cooling, etc..
- Since the charging hose can be connected to can tap valve by hand, do not use a pliers for tightening it.
- Keep refrigerant containers in a cool and dark place avoiding such place which are subject to strong sunlight or high temperature.
- R134a compressor oil absorbs moisture easily, so that be sure to seal after disconnecting the each parts.
- Do not use old-type refrigerant R12a or compressor oil for old-type refrigerant.
- When replacing the condenser, evaporator and receiver, etc., replenish the compressor oil to compressor according to the table below.

### (Reference)

Replacing Parts	Replenish Quantity	Brand Name
Condenser	20 cc 0.021 U.S.qts. 0.018 Imp.qts.	ND-OIL 8 <PAG* oil>
Evaporator	20 cc 0.021 U.S.qts. 0.018 Imp.qts.	
Receiver	10 cc 0.011 U.S.qts. 0.009 Imp.qts.	

\*PAG : Polyalkyleneglycol (Synthetic oil)

W1012709

# [1] HANDLING OF SERVICE TOOLS

## (1) Manifold Gauge Set

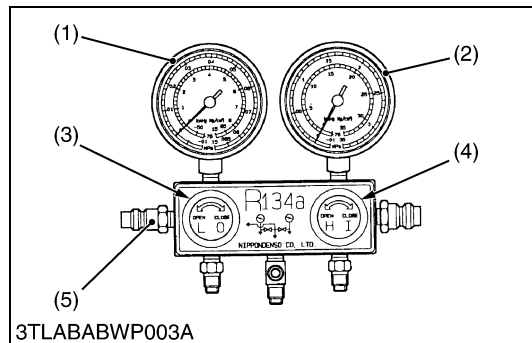

The hand valves on the manifold gauge set are used to open and close the valve. The hand valve inscribed **LO** is for the low pressure side valve (3) and **HI** is for the high pressure side valve (4). By opening or closing the high and low pressure hand valves, the following circuits are established.

- |                            |                            |
|----------------------------|----------------------------|
| (1) LO Pressure Gauge      | (4) HI Pressure Side Valve |
| (2) HI Pressure Gauge      | (5) Schrader Valve         |
| (3) LO Pressure Side Valve |                            |

W1013107

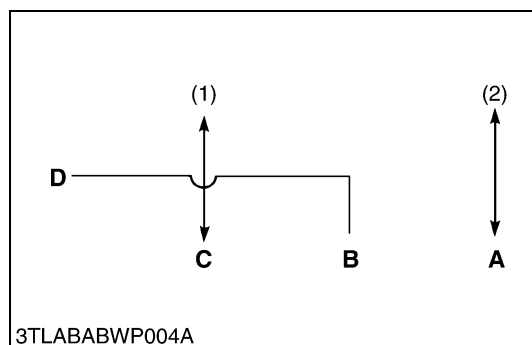

### ■ When LO Pressure Side Valve and HI Pressure Side Valve are Closed

Two circuits are established.  
 Port (C) → LO pressure gauge (1)  
 Port (A) → HI pressure gauge (2)

#### ■ NOTE

- Schrader valve (D) must be opened.

W1013376

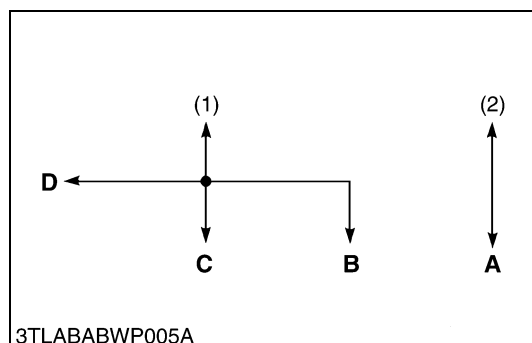

### ■ When LO Valve is Opened and HI Valve is Closed

Two circuits are established.  
 Port (C) → LO pressure gauge (1)  
     → Port (B)  
     → Port (D)  
 Port (A) → HI pressure gauge (2)

#### ■ NOTE

- Schrader valve (D) must be opened.

W1013454

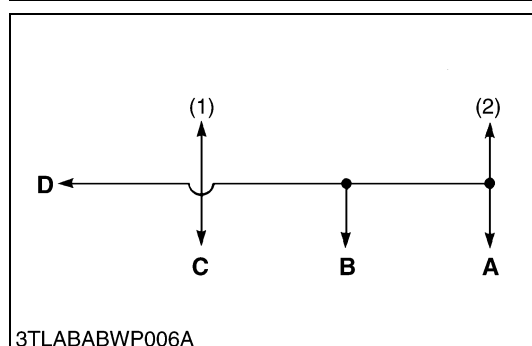

### ■ When LO Valve is Closed and HI Valve is Opened

Two circuits are established.  
 Port (C) → HI pressure gauge (2)  
     → Port (B)  
     → Port (D) (Schrader valve must be opened)  
 Port (A) → LO pressure gauge (1)

#### ■ NOTE

- Schrader valve (D) must be opened.

W1013304

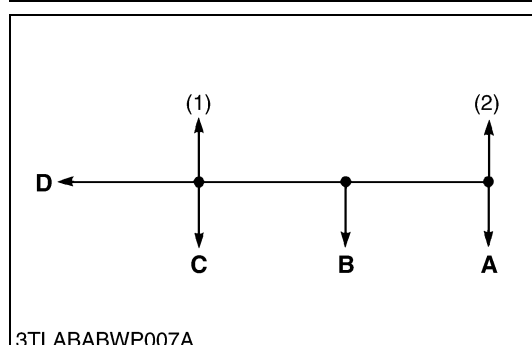

### ■ When LO and HI Valve are Opened

Circuits are established.  
 Port (A) → HI pressure gauge (2)  
     → LO pressure gauge (1)  
     → Port (B)  
     → Port (C)  
     → Port (D) (Schrader valve must be opened)

#### ■ NOTE

- Schrader valve (D) must be opened.

W1013864

## (2) Refrigerant Charging Hose

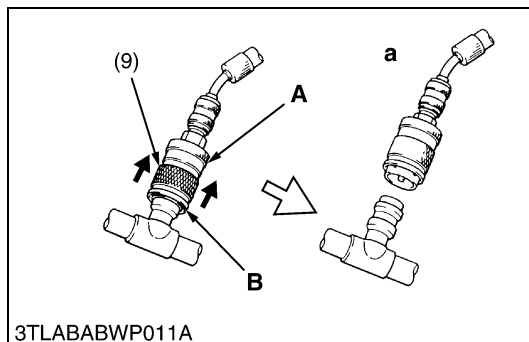
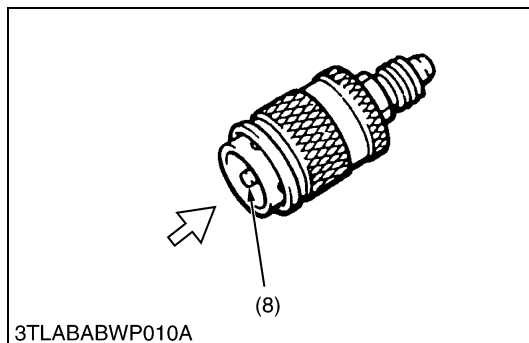
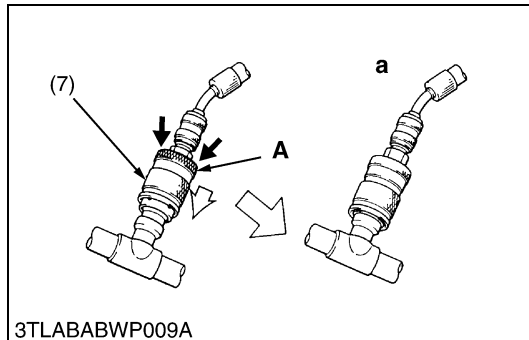
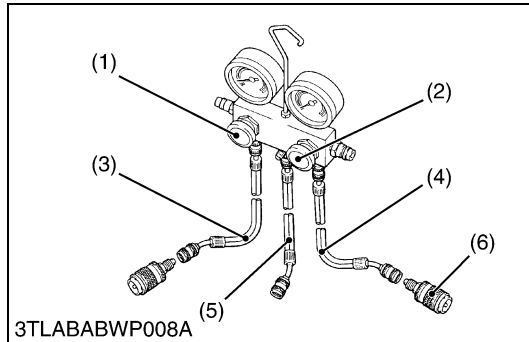

The charging hoses are classified into three colors. Each charging hose must be handled as follows :

- The air conditioner manufacture recommends that the blue hose (3) is used for the **LO** pressure side (suction side), the green hose (5) for refrigeration side (center connecting port) and the red hose (4) for **HI** pressure side (discharged side).

### (When connecting)

- Push the quick disconnect adaptor (6) into the charging valve, and push on part **A** until a click is heard.

### ■ NOTE

- When connecting, push carefully so the pipe doesn't bend.
- When connecting the quick disconnect connector, should the sleeve (7) move before the quick link connector can be connected to the charging valve, move the quick sleeve to its original position and try again.
- When some refrigerant remains in the charging hose at the time of connections, it may be difficult to connect the quick link connector. In this case, perform the operation after removing any residual pressure in the hose. (Remove the residual pressure by pushing the pusher (8).)

### (When reassembling)

- While holding on to part **A** of the quick disconnect adaptor, slide part **B** up.

### ■ NOTE

- After removing the adaptor, ensure to cap the quick disconnect adaptor service valve.

- |                              |                  |
|------------------------------|------------------|
| (1) LO Pressure Side Valve   | (7) Sleeve       |
| (2) HI Pressure Side Valve   | (8) Pusher       |
| (3) Blue Hose                | (9) Sleeve       |
| (4) Red Hose                 |                  |
| (5) Green Hose               | a : <b>CLICK</b> |
| (6) Quick Disconnect Adaptor |                  |

W1014039

### (3) Vacuum Pump Adaptor

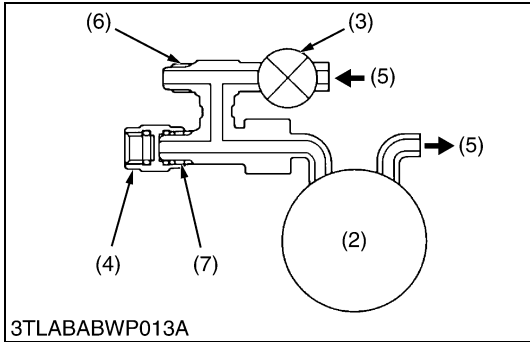
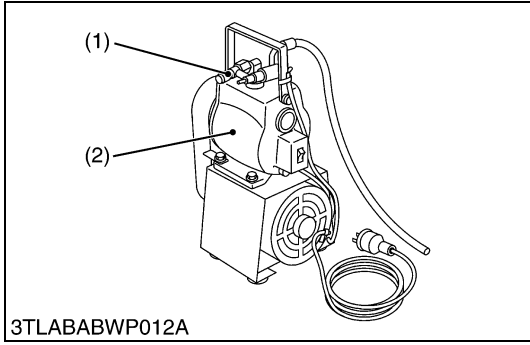

#### Objective of the Vacuum Pump Adaptor

1. After vacuum has been created in the air conditioning cycle, when the vacuum pump is stopped, since there is vacuum in hoses within the gauge manifold, the vacuum pump oil flows back into the charging hose. If the refrigerant is refilled with the system still in this state, the vacuum pump oil left in the charging hose enters the air conditioner cycle together with the refrigerant. Vacuum pump adaptor with a solenoid valve is used to prevent this back-flow of oil from the vacuum pump. The role of the solenoid valve is that when the current passes through the solenoid valve, the valve closes to keep out the outside air and allow the vacuum to build up, but when the current stops, the valve opens to allow in air and end the vacuum.
2. Attaching this adaptor to the R12 vacuum pump currently being used allows the pump to be used with both R134a and R12.

- |                         |               |
|-------------------------|---------------|
| (1) Vacuum Pump Adaptor | (6) For R134a |
| (2) Vacuum Pump         | (7) For R12   |
| (3) Magnetic Valve      |               |
| (4) Blind Cap           |               |
| (5) Air                 |               |

W1014539

### (4) Electric Gas Leak Tester

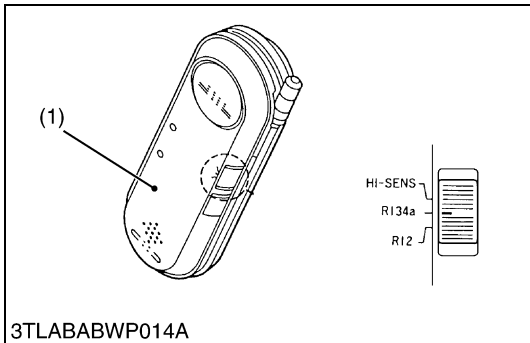

The current R12 gas leak tester has poor sensitivity for R134a and cannot be used. Therefore, a new electric gas leak tester with greater sensitivity has been designed and can be used with both R134a and R12.

#### (Reference)

Leak tester with halide torch

- Since the reaction with chlorine within the refrigerant is used to detect gas leaks, R134a, which contains no chlorine, cannot be detected.

- (1) Electric Gas Leak Tester

W1014905

### (5) Can Tap Valve

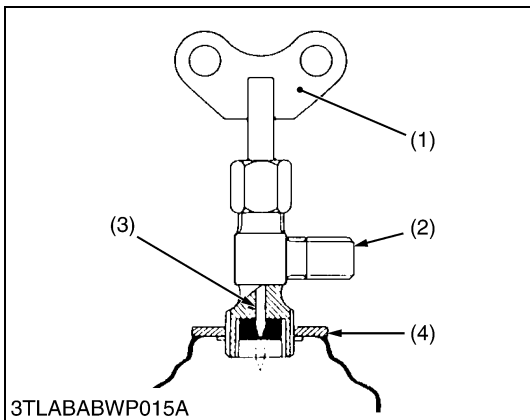

The can tap valve that is used to charge the refrigerant into the air conditioning system, should be used as follows :

1. Before putting the can tap valve on the refrigerant container, turn the handle (1) counterclockwise till the valve needle is fully retracted.
2. Turn the plate nut (disc) (4) counterclockwise till it reaches its highest position, then screw down the can tap valve into the sealed tap.
3. Turn the plate nut clockwise fully, and fix the center charging hose to the valve.
4. Tighten the plate nut firmly by hand.
5. Turn the handle (1) clockwise, thus making a hole in the sealed tap.
6. To charge the refrigerant into the system, turn the handle (1) counterclockwise. To stop charging, turn it clockwise.

- |                      |            |
|----------------------|------------|
| (1) Butterfly Handle | (3) Needle |
| (2) Connection       | (4) Disc   |

W1015014

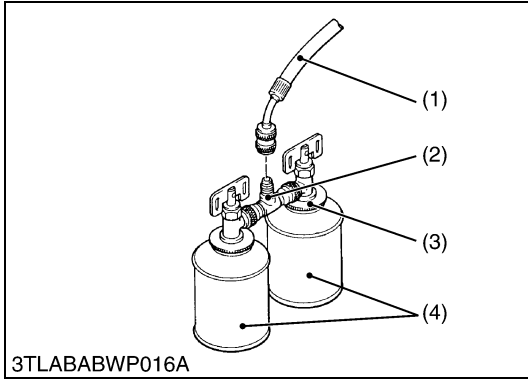

**(6) T-joint**

T-joint (2) is used to increase efficiency of gas charging using two refrigerant containers (4) at a time.

1. Install two refrigerant container service valves to T-joint (2) sides and connect the charging hose (1) to it.

(1) Charging Hose (Green)

(3) Can Tap Valve

(2) T-joint

(4) Refrigerant Container

W1015169

**(7) R134a Refrigerant Recovery and Recycling Machine**

When there is necessity of discharging the refrigerant on repairing the tractor, it should use recovery and recycling machine. (Don't release the refrigerant into the atmosphere.)

**■ IMPORTANT**

- Use only R134a refrigerant recovery and recycling machine, eliminate mixing R134a equipment, refrigerant and refrigerant oils with R12 systems to prevent compressor damage.

W1015488

## 5. CHECKING AND CHARGING REFRIGERANT CYCLE

### [1] CHECKING WITH MANIFOLD GAUGE

#### ■ IMPORTANT

- The gauge indications described in the following testing are those taken under the same condition, so it should be noted that the gauge readings will differ somewhat with the ambient conditions.

#### Condition

- Ambient temperature : 30 to 35 °C (86 to 95 °F)
- Engine speed : Approx. 1500 min<sup>-1</sup> (rpm)
- Temperature control lever : **Maximum cooling position**
- Air-Conditioner switch : **ON**
- Blower switch : **HI** position

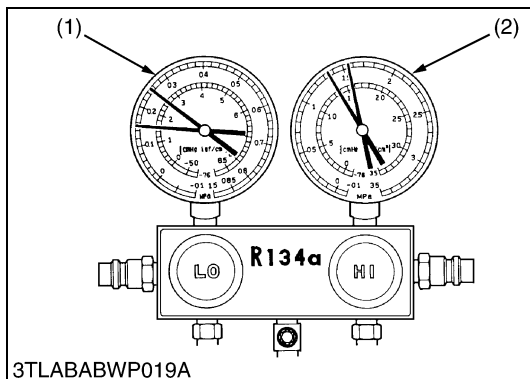
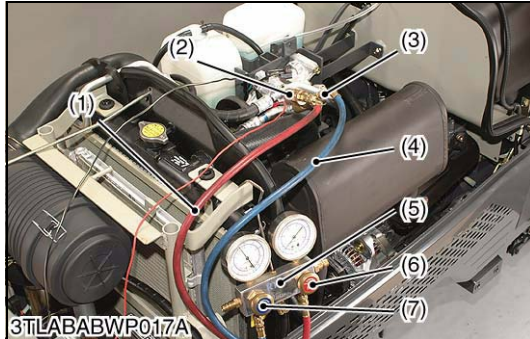

#### Manifold Gauge Connecting and Test Preparation

1. Close the manifold gauge **HI** and **LO** pressure side valve (7), (6) tightly.
2. Connect the charging hose (1) (red) to the **HI** pressure side charging valve (2) and connect the charging hose (4) (blue) to the **LO** pressure side charging valve (3).

#### ■ NOTE

- **Be sure to drive out the air in the charging hoses at the manifold gauge connection end by utilizing the refrigerant pressure in the refrigerating cycle.**
3. Start the engine and set at approx. 1500 min<sup>-1</sup> (rpm).
  4. Turn on the A/C switch and set the temperature control lever to **maximum cooling** position.
  5. Set the blower switch to **HI** position.

- |  |                                   |
|--|-----------------------------------|
| (1) Charging Hose (Red)                    | (5) Manifold Gauge                |
| (2) <b>HI</b> Pressure Side Charging Valve | (6) <b>HI</b> Pressure Side Valve |
| (3) <b>LO</b> Pressure Side Charging Valve | (7) <b>LO</b> Pressure Side Valve |
| (4) Charging Hose (Blue)                   |                                   |

W1015662

#### Normal Operating

If the refrigerating cycle is operating normally, the reading at the **LO** pressure side (1) should be generally by around 0.15 to 0.2 MPa (1.5 to 2.0 kgf/cm<sup>2</sup>, 21 to 28 psi) and that at the **HI** pressure side (2) around 1.27 to 1.66 MPa (13 to 17 kgf/cm<sup>2</sup>, 185 to 242 psi).

Gas pressure	Factory spec.	Low pressure side	0.15 to 0.20 MPa 1.5 to 2.0 kgf/cm <sup>2</sup> 21 to 28 psi
		High pressure side	1.27 to 1.66 MPa 13 to 17 kgf/cm <sup>2</sup> 185 to 242 psi

(1) **LO** Pressure Side(2) **HI** Pressure Side

W1015870

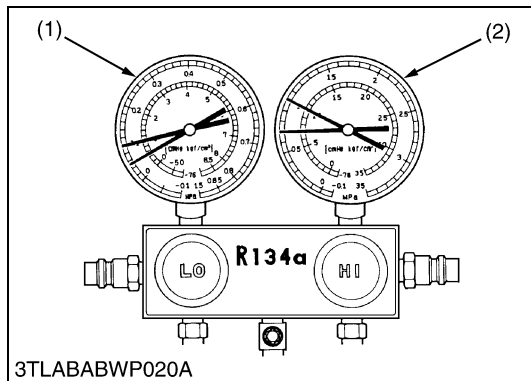

### Insufficient Refrigerant

- Symptoms seen in refrigerating cycle
  - Both **LO** and **HI** pressure side (1), (2) pressures too low.
    - LO** pressure side (1) : 0.05 to 0.1 MPa  
(0.5 to 1.0 kgf/cm<sup>2</sup>, 7.1 to 14.2 psi)
    - HI** pressure side (2) : 0.69 to 0.98 MPa  
(7 to 10 kgf/cm<sup>2</sup>, 99.6 to 142.2 psi)
  - Bubbles seen in sight glass.
  - Air discharged from air conditioner slightly cold.
- Probable cause
  - Gas leaking from some place in refrigerant cycle.
- Solution
  - Check for leakage with electric gas leak tester (see page 10-S11) and repair.
  - Recharge refrigerant to the proper level. (See page 10-S21.)

(1) **LO** Pressure Side(2) **HI** Pressure Side

W1016070

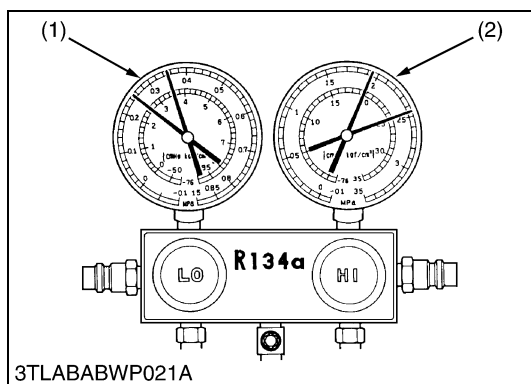

### Excessive Refrigerant or Insufficient Condenser Cooling

- Symptoms seen in refrigerating cycle
  - Both **LO** and **HI** pressure side (1), (2) pressures too high.
    - LO** pressure side (1) : 0.2 to 0.35 MPa  
(2.0 to 3.5 kgf/cm<sup>2</sup>, 28 to 49.8 psi)
    - HI** pressure side (2) : 1.96 to 2.45 MPa  
(20 to 25 kgf/cm<sup>2</sup>, 284.5 to 355.6 psi)
- Probable cause
  - Overcharging refrigerant into cycle.
  - Condenser cooling faulty.
- Solution
  - Clean condenser. (See page G-31.)
  - Adjust air conditioner belt to proper tension. (See page G-29.)
  - If the above two items are in normal condition, check refrigerant quantity. (See page 10-S21.)

#### NOTE

- If excessive refrigerant is to be discharged, loosen manifold gauge **LO** pressure side valve and vent out slowly.

(1) **LO** Pressure Side(2) **HI** Pressure Side

W1016402

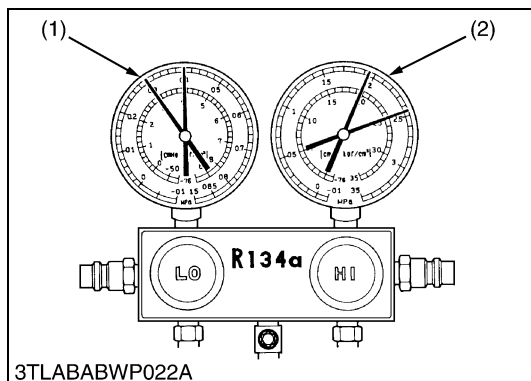

### Air Entered in the Cycle

- Symptoms seen in refrigerating cycle
  - Both **LO** and **HI** pressure side (1), (2) pressures too high.
    - LO** pressure side (1) : 0.2 to 0.35 MPa  
(2.0 to 3.5 kgf/cm<sup>2</sup>, 28 to 49.8 psi)
    - HI** pressure side (2) : 1.96 to 2.45 MPa  
(20 to 25 kgf/cm<sup>2</sup>, 284.5 to 355.6 psi)
  - LO** pressure side (1) piping not cold when touched.
- Probable cause
  - Air entered in refrigerating cycle.
- Solution
  - Replace receiver.
  - Check compressor oil contamination and quantity.
  - Evacuate and recharge new refrigerant. (See page 10-S19, S20.)

#### NOTE

- The above cycle can be seen when the cycle is charged without evacuation.

(1) **LO** Pressure Side(2) **HI** Pressure Side

W1016771

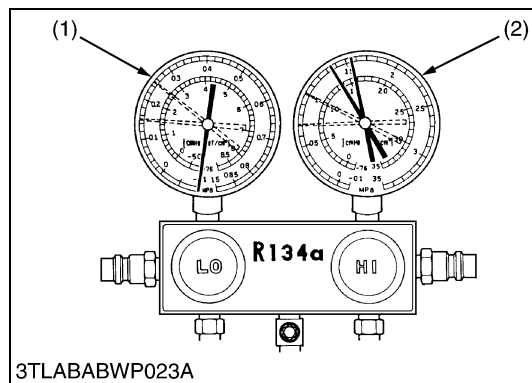

### Moisture Entered in the Cycle

1. Symptoms seen in refrigerating cycle
  - The air conditioner operates normally at the beginning, but over time, **LO** pressure side (1) pressure is **vacuum** and **HI** pressure side (2) is low pressure.
  - LO** pressure side (1) : Vacuum
  - HI** pressure side (2) : 0.69 to 0.98 MPa  
(7 to 10 kgf/cm<sup>2</sup>, 99.6 to 142.2 psi)
2. Probable cause
  - The moisture in the refrigerating cycle freezes in the expansion valve orifice and causes temporary blocking. After a time, the ice melts and condition returns to normal.
3. Solution
  - Replace receiver.
  - Remove moisture in cycle by means of repeated evacuation. (See page 10-S17.)
  - Recharge new refrigerant to the proper level. (See page 10-S21.)

(1) LO Pressure Side

(2) HI Pressure Side

W1017013

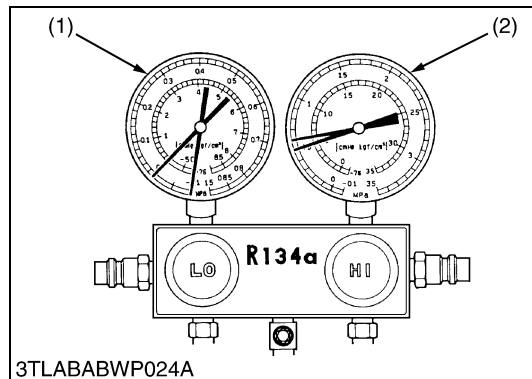

### Refrigerant Fails to Circulate

1. Symptoms seen in refrigerating cycle
  - **LO** pressure side (1) pressure is **vacuum** and, **HI** pressure side (2) is **low** pressure.
  - LO** pressure side (1) : Vacuum
  - HI** pressure side (2) : 0.49 to 0.59 MPa  
(5 to 6 kgf/cm<sup>2</sup>, 71.2 to 85.3 psi)
  - Frost or dew formed on piping at front and rear sides of expansion valve or receiver.
2. Probable cause
  - Refrigerant flow obstructed by moisture or dirt in the refrigerating cycle freezing or sticking on the expansion valve orifice.
3. Solution
 

Allow to stand for same time and then resume operation to decide whether the plugging is due to moisture or dirt.

  - If caused by moisture, correct by referring to instructions in previous.
  - If caused by dirt, remove the expansion valve and blow out the dirt with compressed air.
  - If unable to remove the dirt, replace the expansion valve. Replace the receiver. Evacuate and charge in proper amount of new refrigerant. (See page 10-S18 to S20.)
  - If caused by gas leakage in heat sensitizing tube, replace the expansion valve.

(1) LO Pressure Side

(2) HI Pressure Side

W1017346

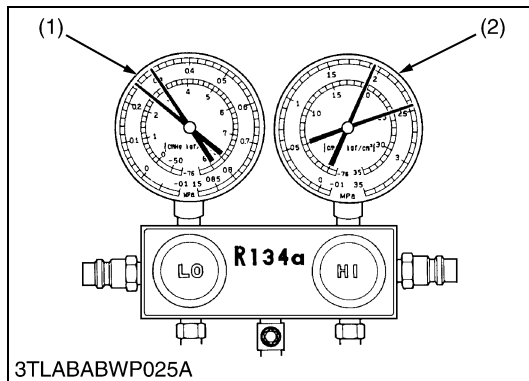

### Expansion Valve Opens Too Far or Improper Installation of Heat Sensitizing Tube

- Symptoms seen in refrigerating cycle
  - Both **LO** and **HI** pressure side (1), (2) pressures too high.
    - LO** pressure side (1) : 0.29 to 0.39 MPa  
(3.0 to 4.0 kgf/cm<sup>2</sup>, 42.71 to 56.9 psi)
    - HI** pressure side (2) : 1.96 to 2.45 MPa  
(20 to 25 kgf/cm<sup>2</sup>, 284.5 to 355.6 psi)
  - Frost or heavy dew on low pressure side piping.
- Probable cause
  - Expansion valve trouble or heat sensitizer tube improperly installed.
  - Flow adjustment not properly done.
- Solution
  - Check installed condition of heat sensitizer tube.
  - If installation of heat sensitizer tube is correct, replace the expansion valve.

(1) **LO** Pressure Side(2) **HI** Pressure Side

W1017612

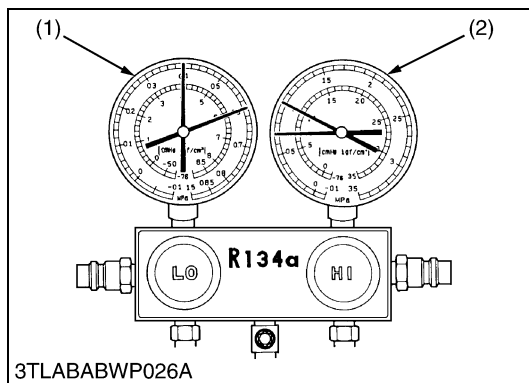

### Faulty Compression of Compressor

- Symptoms seen in refrigerating cycle
  - LO** pressure side (1) pressure too high : 0.39 to 0.59 MPa (4 to 6 kgf/cm<sup>2</sup>, 56.9 to 85.3 psi)
  - HI** pressure side (2) pressure too low : 0.69 to 0.98 MPa (7 to 10 kgf/cm<sup>2</sup>, 99.6 to 142.2 psi)
- Probable cause
  - Leak in compressor.
- Solution
  - Replace compressor. (See page 10-S29.)

#### ■ NOTE

- Manifold gauge indications (left side figure) at faulty compressing by compressor.**

(1) **LO** Pressure Side(2) **HI** Pressure Side

W1017960

## [2] DISCHARGING, EVACUATING AND CHARGING

### ■ IMPORTANT

- When discharging, evacuating or charging the refrigerating system, be sure to observe the “PRECAUTION AT REPAIRING REFRIGERANT CYCLE”. (See page 10-S8.)

### (1) Discharging the System

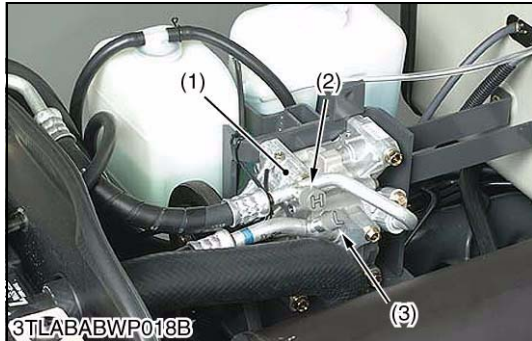

Prepare for the R134a refrigerant recovery and recycling machine.

1. Connect low pressure side hose (blue) from the recovery and recycling machine to **LO** pressure side charging valve (3) on the compressor (1). Connect high pressure side hose (red) to **HI** pressure side charging valve (2) on the compressor (1).
2. Follow the manufacturers instructions and discharge the system.

### ■ IMPORTANT

- Use only R134a refrigerant recovery and recycling machine. Eliminate mixing R134a equipment, refrigerant, and refrigerant oils with R12 systems to prevent compressor damage.

### ⚠ CAUTION

- Protect fingers with cloth against frostbite by refrigerant when disconnecting the hose to the charging valve.

- (1) Compressor (3) LO Pressure Side Charging Valve  
 (2) HI Pressure Side Charging Valve

W1018328

### (2) Evacuating the System

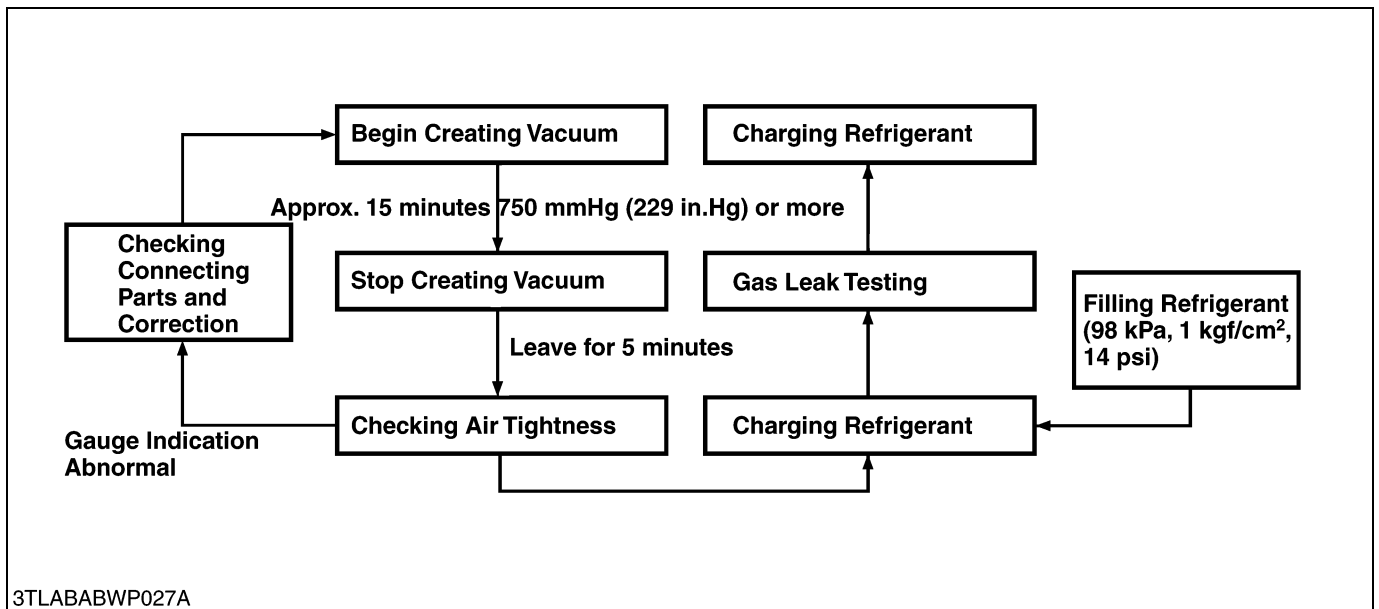



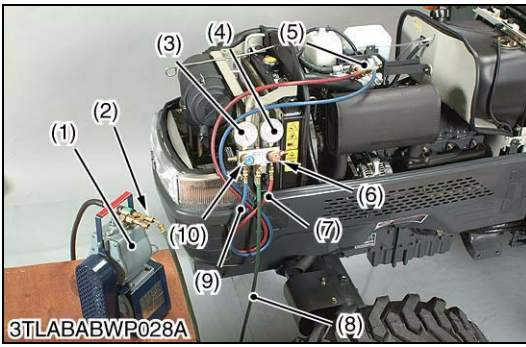

### Evacuating the System

1. Discharge refrigerant from the system by R134a refrigerant recovery and recycling machine. (Refer to “Discharging the system”.)
2. Connect the charging hose (7) (red) to the **HI** pressure side charging valve and connect the charging hose (9) (blue) to the **LO** pressure side charging valve.
3. Connect the center charging hose (8) (green) to a vacuum pump inlet.
4. Open both valves (6), (10) of manifold gauge fully. Then run the vacuum pump (1) to evacuate the refrigerant cycle. (For approx. **15 minutes**.)
5. When **LO** pressure gauge (10) reading is more than **750 mmHg (299 in.Hg)**, stop the vacuum pump (8) and close both valves (6), (10) of manifold gauge fully.
6. Wait for over 5 minutes with the **HI** and **LO** pressure side valves (6), (10) of gauge manifold closed, and then check that gauge indicator does not return to 0.
7. If the gauge indicator is going to approach to 0, check whether there is a leaking point and repair if it is, and then evacuate it again.

- (1) Vacuum Pump (Running)
- (2) Vacuum Pump Adaptor
- (3) **LO** Pressure Gauge
- (4) **HI** Pressure Gauge
- (5) Compressor

- (6) **HI** Pressure Side Valve (Open)
- (7) Red Hose
- (8) Green Hose
- (9) Blue Hose
- (10) **LO** Pressure Side Valve (Close)

W1018495

### (3) Charging the System

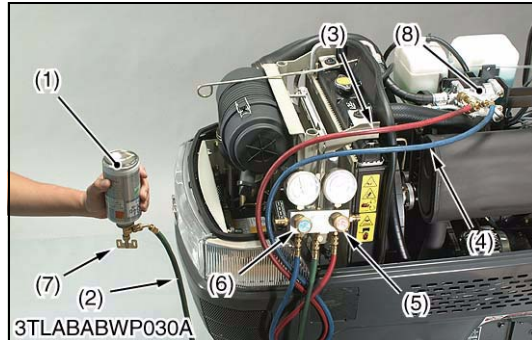
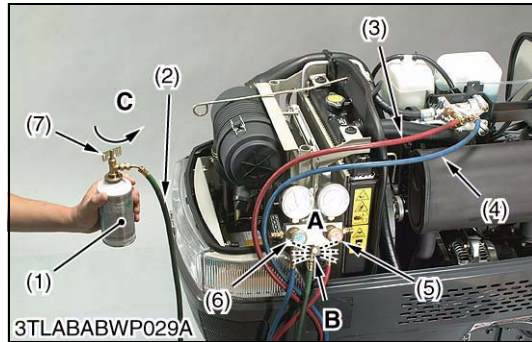

#### Charging an Empty System (Liquid)

This procedure is for charging an empty system through the **HI** pressure side with the refrigerant in the liquid state.

#### ⚠ CAUTION

- Never run the engine when charging the system through the **HI** pressure side.
- Do not open the **LO** pressure valve when refrigerant R134a is being charged in the liquid state (refrigerant container is placed upside-down).

#### ■ IMPORTANT

- After charging the refrigerant in the liquid state with approx. 500 g (1.1 lbs) through the **HI** pressure side, be sure to recharge the refrigerant in the vapor state to specified amount through the **LO** pressure side.

1. Close the **HI** and **LO** pressure side valves (5), (6) of manifold gauge after the system is evacuated completely.
2. Connect the center charging hose (2) to the can tap valve (7) fitting, and then loosen the center charging hose at the center fitting of manifold gauge until hiss can be heard. Allow the air to escape for few seconds and tighten the nut.
3. Open the **HI** pressure side valve (5) fully, and keep the container upside-down to charge the refrigerant in the liquid state from the **HI** pressure side.
4. Charge the refrigerant in the liquid state with approx. 500 g (1.1 lbs) from the **HI** pressure side.

#### ■ NOTE

- If **LO** pressure gauge does not show a reading, the system is clogged and must be repaired.
5. Close the **HI** pressure side valve (5) of manifold gauge and can tap valve of refrigerant container.

- (1) Refrigerant Container (R134a)
- (2) Green Hose
- (3) Red Hose
- (4) Blue Hose
- (5) **HI** Pressure Side Valve (Open)
- (6) **LO** Pressure Side Valve (Close)

- (7) Can Tap Valve (Open)
- (8) Compressor

**A : Air Purge**

**B : Loosen the Nut**

**C : Open the Can Tap Valve**

W1018931

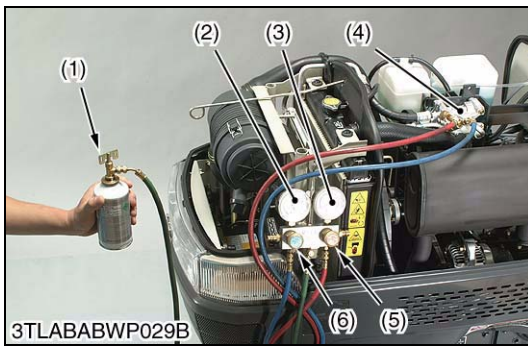

### Charging an Empty or Partially Charged System (Vapor)

This procedure is to charge the system through the **LO** pressure side with refrigerant in the vapor state. When the refrigerant container is placed right side up, refrigerant will enter the system as a vapor.

#### ⚠ CAUTION

- Never open the **HI** pressure valve of manifold gauge while the engine is running.

#### ■ NOTE

- Do not turn the refrigerant container upside-down when charging the system by running the engine.
- Put refrigerant container into a pan of warm water (maximum temperature 40 °C (104 °F)) to keep the vapor pressure in the container slightly higher than vapor pressure in the system.

1. Check that the **HI** pressure valve (5) is closed.
2. Start the engine and set an approx. **1500 min<sup>-1</sup> (rpm)**.
3. Turn on the A/C switch.  
Set the temperature control lever to **maximum cooling** position and the blower switch to **HI** position.
4. Open the **LO** pressure valve (6) of manifold gauge and the can tap valve (1) on refrigerant container and charge the refrigerant until air bubbles in the sight glass of the receiver vanish.
5. After charging the specified amount of refrigerant into the system, close the **LO** pressure valve (6) of manifold gauge and can tap valve (1), then stop the engine.
6. Check for gas leak with an electric gas leak tester (see page 10-S11).

#### (Reference)

- Specified amount of refrigerant (total) :  
900 to 1000 g (2.0 to 2.2 lbs) [Refrigerant R134a]
- Manifold gauge indication at fully charged system (at ambient temperature : 30 °C (86 °F))

**HI** pressure side : 1.27 to 1.66 MPa  
13 to 17 kgf/cm<sup>2</sup>  
185 to 242 psi

**LO** pressure side : 0.15 to 0.20 MPa  
1.5 to 2.0 kgf/cm<sup>2</sup>  
21 to 28 psi

- |                              |                                      |
|------------------------------|--------------------------------------|
| (1) Can Tap Valve            | (4) Compressor (Running)             |
| (2) <b>LO</b> Pressure Gauge | (5) <b>HI</b> Pressure Valve (Close) |
| (3) <b>HI</b> Pressure Gauge | (6) <b>LO</b> Pressure Valve (Open)  |

W1019245

#### (4) Checking Charge Refrigerant Amount

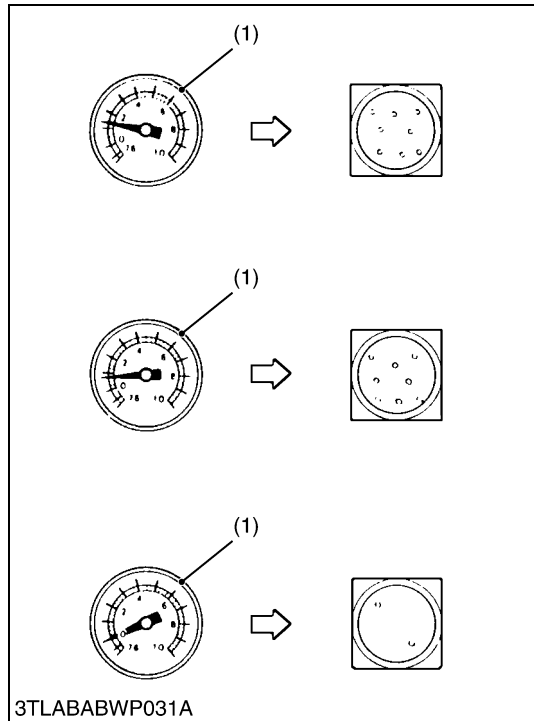
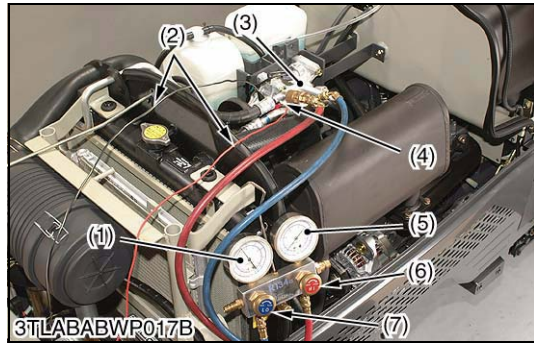

After charging the refrigerant, check for amount of charging refrigerant as follows.

#### ■ NOTE

- The pressure on the following checking are the gauge indications at ambient temperature 30 °C (86 °F), so it should be noted that the pressure will differ some what with the ambient temperature.

1. Disconnect the **2P** connector (4) of magnetic clutch.
2. Start the engine and set a approx. **1500 min<sup>-1</sup> (rpm)**.
3. Connect the **2P** connector (4) of magnetic clutch to battery directly, and then set the blower switch to **HI** position.
4. Leave the system for approx. **5 minutes** until the refrigerant cycle becomes stable, keeping pressure on the **HI** pressure side from 1.27 to 1.66 MPa (13 to 17 kgf/cm<sup>2</sup>, 185 to 242 psi).
5. When the refrigerant cycle is stabilizer, turn off the blower switch and let the compressor alone to run. Then pressure on the **LO** pressure side gradually drops. At this time, if pressure on the **HI** pressure side is maintained from 1.27 to 1.66 MPa (13 to 17 kgf/cm<sup>2</sup>, 185 to 242 psi), air bubbles which pass through the sight glass becomes as stated below depending on refrigerant charged amount.

#### A : Insufficient refrigerant charge

Air bubbles pass continuously the sight glass when pressure on the **LO** pressure side is over 99.0 kPa (1.01 kgf/cm<sup>2</sup>, 14.4 psi). In this case, charge the refrigerant from the **LO** pressure side.

#### B : Properly refrigerant charge

Air bubbles pass through the sight glass continuously when pressure on the **LO** pressure side is within 59 to 98 kPa (0.6 to 1.0 kgf/cm<sup>2</sup>, 9 to 14 psi).

If the charge refrigerant amount is proper, no air bubble is observed on the sight glass at pressure on the **LO** pressure side over 99.0 kPa (1.01 kgf/cm<sup>2</sup>, 14.4 psi) when the blower switch is turned on. When the blower switch is turned off, bubbles pass through the sight glass in case pressure on the **LO** pressure side is within 59 to 98 kPa (0.6 to 1.0 kgf/cm<sup>2</sup>, 9 to 14 psi).

#### C : Excessive refrigerant charge

Air bubbles pass through the sight glass time to time or no air bubble is observed when pressure on the **LO** pressure side is under 59 kPa (0.6 kgf/cm<sup>2</sup>, 9 psi).

In this case, discharge excessive refrigerant gradually from the **LO** pressure side.

- |                              |                                      |
|------------------------------|--------------------------------------|
| (1) <b>LO</b> Pressure Gauge | (5) <b>HI</b> Pressure Gauge         |
| (2) To Battery               | (6) <b>HI</b> Pressure Valve (Close) |
| (3) Compressor (Running)     | (7) <b>LO</b> Pressure Valve (Close) |
| (4) <b>2P</b> Connector      |                                      |

W1019604

## 6. CHECKING, DISASSEMBLING AND SERVICING

### [1] SEPARATING CABIN FROM TRACTOR BODY

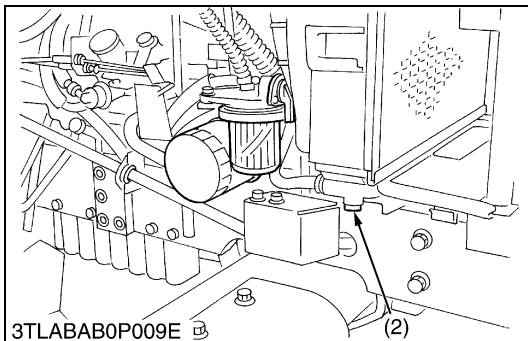
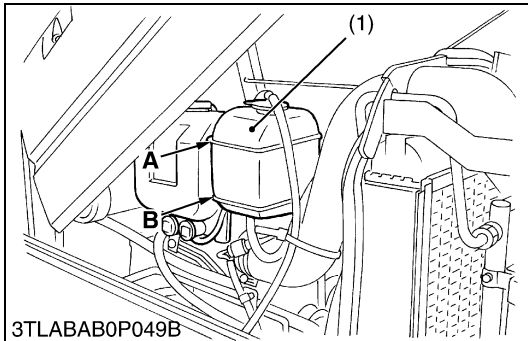

#### Draining Coolant

#### ⚠ CAUTION

- Never remove the radiator cap until coolant temperature is well below its boiling point. Then loosen cap slightly to the stop to relieve any excess pressure before removing cap completely.

1. Stop the engine and let cool down.
2. Loosen the drain plug (2) to drain the coolant.
3. Remove the radiator cap to completely drain the coolant.
4. After all coolant is drained, retighten the drain plug (2).

#### (When refilling)

- Fill the coolant between the “FULL” and “LOW” marks of recovery tank (1).

Coolant capacity (with recovery tank)	L3830 L4630	8.7 L 9.2 U.S.qts 7.7 Imp.qts
	L5030	9.2 L 9.7 U.S.qts 8.1 Imp.qts

- (1) Recovery Tank  
(2) Drain Plug

A : FULL  
B : LOW

W10590830



#### Battery, Front Grill, Skirt and Bonnet

1. Open the bonnet and disconnect the battery negative cable.
2. Disconnect the head light connector and remove the front grill (4).
3. Remove the left and right side skirts (3).
4. Disconnect window washer hoses (2).
5. Remove the bonnet (1).

#### ■ NOTE

- When disconnecting the battery cords, disconnect the negative cord first, when connecting, positive cord first.

- (1) Bonnet (3) Skirt  
(2) Window Washer Hose (4) Front Grill

W1059877



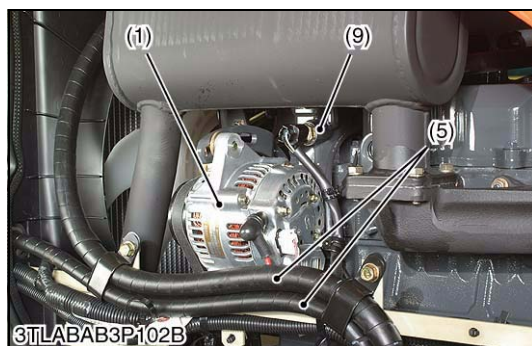
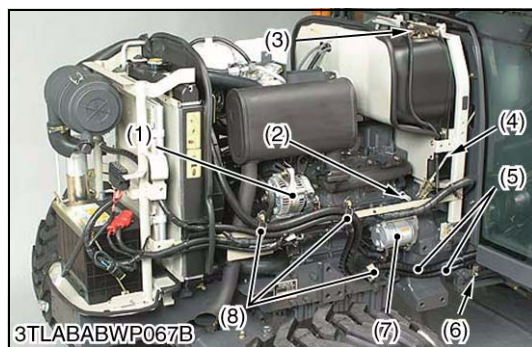
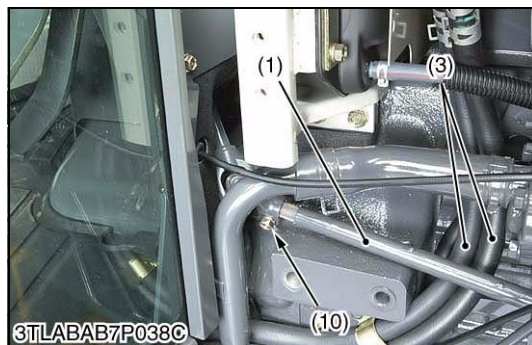
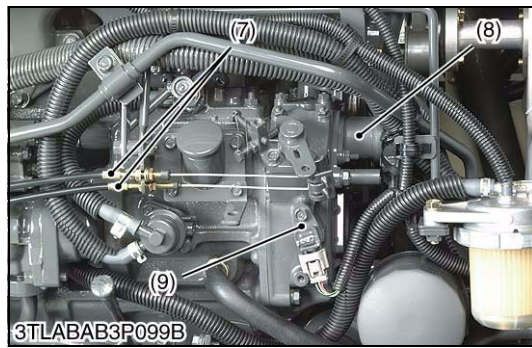
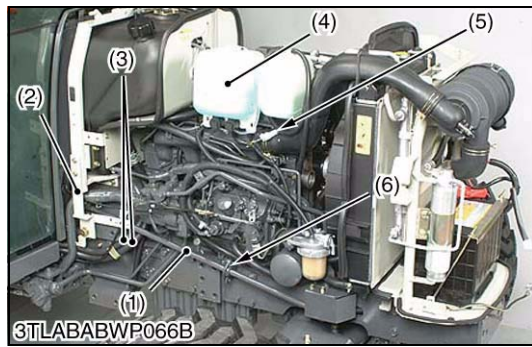

### Steering Joint, Brake Pedal Rod and Electric Wiring

1. Remove the tank frame support (2).
2. Remove the universal joint bolt (10) and steering joint support (6), and then remove the steering joint (1).
3. Disconnect the hand accelerator wire and foot accelerator wire (7). (A foot accelerator is not equipped in HST model.)
4. Disconnect the wiring connectors for engine stop solenoid (8), engine tachometer sensor (9) and glow plug.
5. Disconnect the heater hoses (3), and then reconnect their hoses to make loop.

#### ■ NOTE

- Put a mark to the each heater hose before disconnecting.
6. Disconnect the wiring connector for window washer tank (4) and compressor 1P connector (5). (A/C model)
  7. Disconnect the brake pedal rod.

#### (When reassembling)

- When accelerator wire is installed, adjust the wiring length as hit both the idling speed adjusting bolt and the maximum speed adjusting bolt by lever within the stroke of the accelerator lever.
- Set the steering joint (1) by the joint support (6) so that the steering wheel is turned lightly.
- Be sure to check and adjust the brake pedal free travel. (See page G-18.)

- |                        |                              |
|------------------------|------------------------------|
| (1) Steering Joint     | (6) Steering Joint Support   |
| (2) Tank Frame Support | (7) Accelerator Wire         |
| (3) Heater Hose        | (8) Engine Stop Solenoid     |
| (4) Window Washer Tank | (9) Engine Tachometer Sensor |
| (5) 1P Connector       | (10) Universal Joint Bolt    |

W1060784

### Clutch Rod, Brake Pedal Rod and Electric Wiring

1. Disconnect the brake pedal rod (6) and clutch rod (4).
2. Disconnect the wiring connectors for alternator (1), coolant temperature sensor (9), oil pressure switch (2), fuel unit (3), starter motor (7) and battery.
3. Remove the clamps and ground earth of wiring harness and collect wiring harness to the step or cabin.
4. Remove the clamps (8) of A/C hoses (5). (A/C model)

#### (When reassembling)

- Be sure to check and adjust the clutch and brake pedal free travel. (See page G-18, 24.)

- |                         |                                |
|-------------------------|--------------------------------|
| (1) Alternator          | (6) Brake Pedal Rod            |
| (2) Oil Pressure Switch | (7) Starter Motor              |
| (3) Fuel Unit           | (8) Clamps                     |
| (4) Clutch Rod          | (9) Coolant Temperature Sensor |
| (5) A/C Hoses           |                                |

W1061143



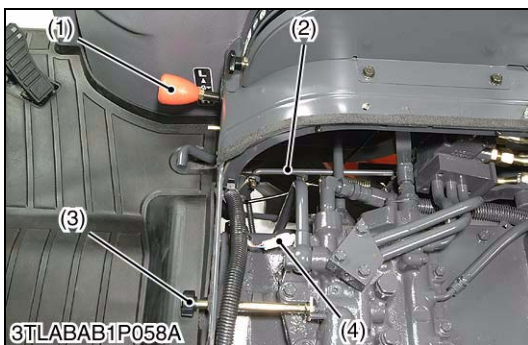

### Seat, Seat Bracket and Lever Grips

1. Remove the seat (1) with seat bracket.
2. Remove the front wheel drive lever (4).

#### **(Manual Transmission Model)**

3. Remove the lever grip for position control lever (5), range gear shift lever (2), creep shift lever (7), main shift lever (3).

#### **(GST Model)**

3. Remove the lever grip for position control lever (5), draft control lever (6), GST lever (8), creep shift lever (7).

#### **(HST Model)**

3. Remove the lever grip for position control lever (5), range gear shift lever (2) and cruise control lever (9).

- |                             |                          |
|-----------------------------|--------------------------|
| (1) Seat                    | (8) GST Lever            |
| (2) Range Gear Shift Lever  | (9) Cruise Control Lever |
| (3) Main Gear Shift Lever   |                          |
| (4) Front Wheel Drive Lever |                          |
| (5) Position Control Lever  |                          |
| (6) Draft Control Lever     |                          |
| (7) Creep Shift Lever       |                          |

**A : Manual Transmission Model**

**B : GST Model**

**C : HST Model**

W1027110

### Differential Lock Rod, Lowering Speed Adjusting Knob and PTO Speed Change Lever (if equipped) (Manual and GST Model)

1. Disconnect the differential lock rod (2).
2. Remove the lowering speed adjusting knob (3).
3. Remove the PTO speed change lever (1) (if equipped).
4. Disconnect the PTO speed sensor (4) (if equipped).

- |                            |                                   |
|----------------------------|-----------------------------------|
| (1) PTO Speed Change Lever | (3) Lowering Speed Adjusting Knob |
| (2) Differential Lock Rod  | (4) PTO Speed Sensor              |

W1027485

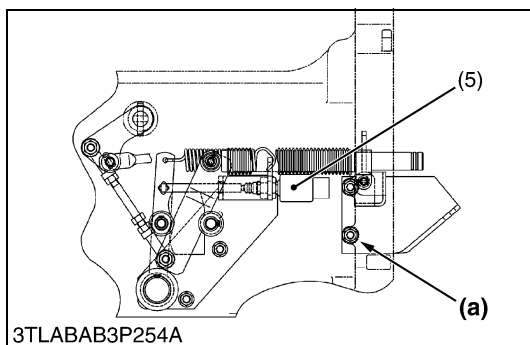
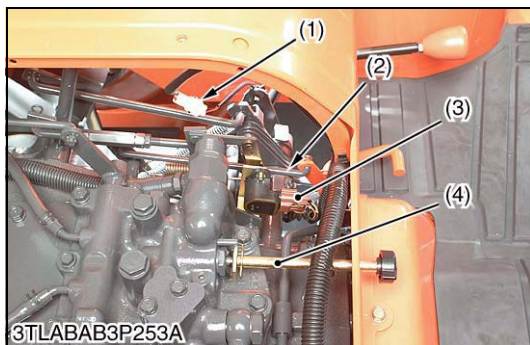
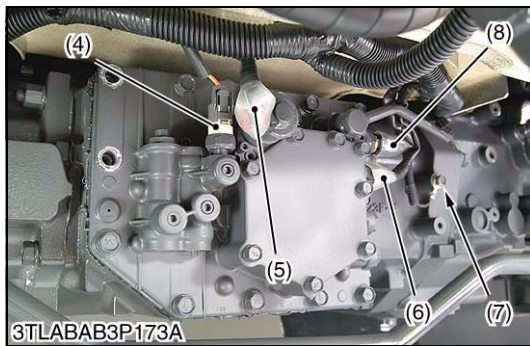
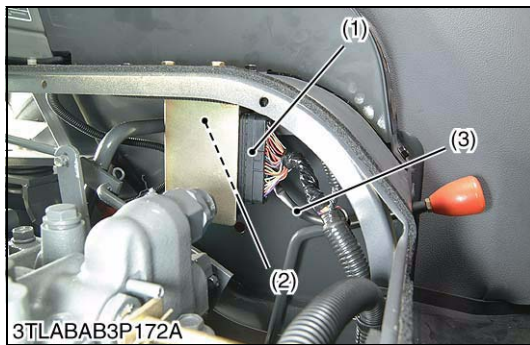

### Electric Connector for GST

1. Disconnect the ECU connector (1).
2. Disconnect the GST lever sensor connector (2).
3. Remove the GST valve cover.
4. Disconnect the pressure switch connector (4), proportional reducing valve connector (5), solenoid valve connector (6), oil temperature sensor connector (8) and ground cables (7).

- |  |   |
|--|---|
| (1) ECU Connector                      | (5) Proportional Reducing Valve Connector |
| (2) GST Lever Sensor Connector         | (6) Solenoid Valve Connector              |
| (3) Wiring Harness of GST Lever Sensor | (7) Ground Cable                          |
| (4) Pressure Switch Connector          | (8) Oil Temperature Sensor Connector      |

W1062110

### Electric Connector for HST

1. Remove the lowering speed adjusting knob (4).
2. Disconnect the differential lock rod (2).
3. Disconnect the range gear shift lever sensor connector (3).
4. Disconnect the cruise switch connector (1).
5. Disconnect the HST pedal neutral switch connector (5).
6. Disconnect the ground earth **(a)**.

- |   |  |
|---|--|
| (1) Cruise Switch Connector                 | (4) Lowering Speed Adjusting Knob      |
| (2) Differential Lock Pedal                 | (5) HST Pedal Neutral Switch Connector |
| (3) Range Gear Shift Lever Sensor Connector |  |
- (a) Ground earth is connected here**

W1062242



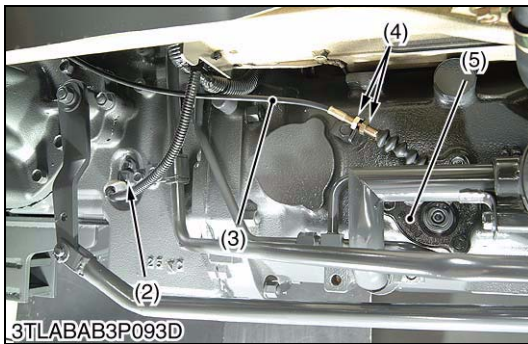
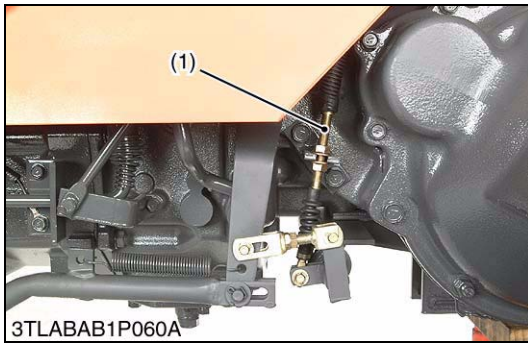

### PTO Shift Wire, Parking Brake Cable and Connector

1. Disconnect the parking brake cable (1).
2. Disconnect the PTO shift wire (3) at the PTO clutch valve (5).
3. Disconnect the traveling speed sensor connector (2).

#### **(When reassembling)**

- Be sure to check and adjust the parking brake lever free play (see page G-27).
- When connecting the PTO shift wire (3) to the clutch valve lever, be sure to adjust the length of wire as follows.
  1. Set the PTO shift lever to **OFF (Neutral)** position.
  2. Loosen the lock nut (4) of wire, and connect wire to the clutch valve lever, and then place the wire to the hook.
  3. Tighten the lock nut (4) clockwise (pull the wire), and lock the nut just before the lever moves.

- |                                      |                      |
|--------------------------------------|----------------------|
| (1) Parking Brake Cable              | (4) Lock Nut         |
| (2) Traveling Speed Sensor Connector | (5) PTO Clutch Valve |
| (3) PTO Shift Wire                   |                      |

W1027788

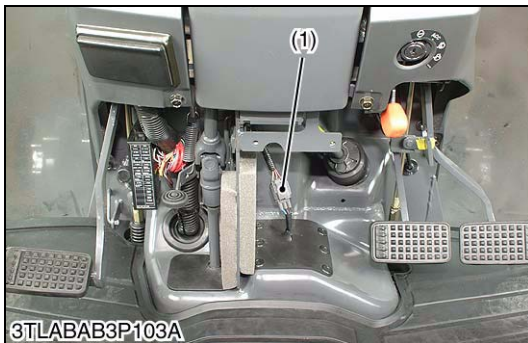

### Shuttle Switch Connector (Manual and GST Model)

1. Remove the panel cover and steering post cover.
2. Disconnect the shuttle switch connector (1).

- (1) Shuttle Switch Connector

W1062664



### Cruise Control Release Wire (HST Model)

1. Disconnect the cruise control release wire (1).

#### **(When reassembling)**

- Be sure to adjust the cruise control release wire (1). (See page 3-S92.)

- (1) Cruise Control Release Wire

W1062741

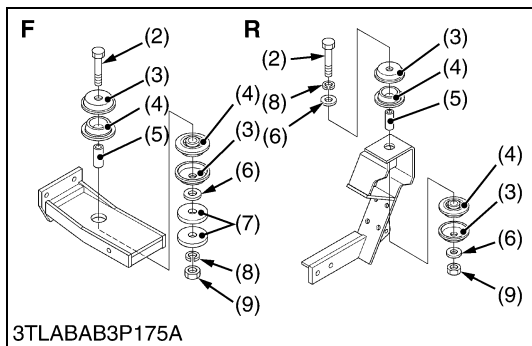
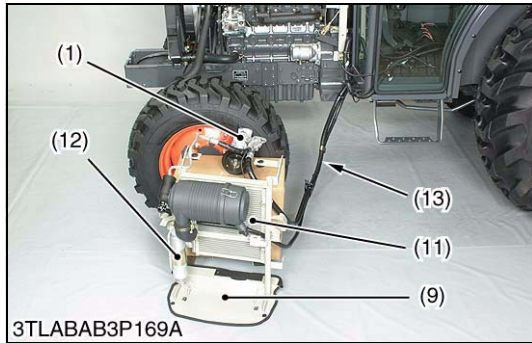
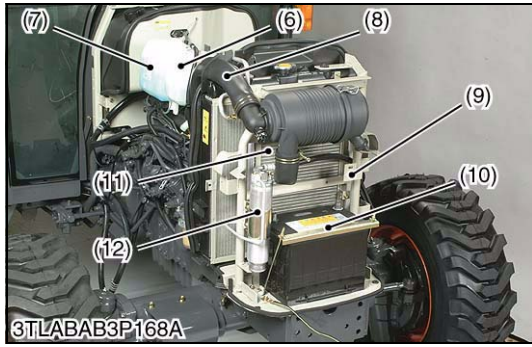
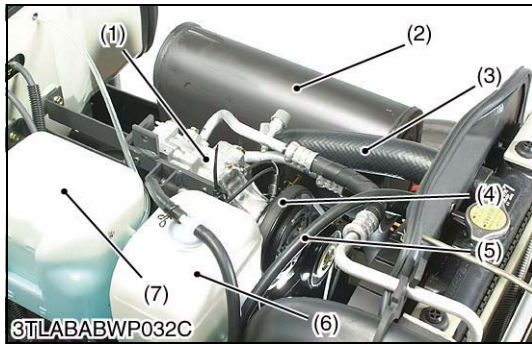

**Air Conditioner Parts (A/C Model)**

1. Remove the muffler (2).
2. Remove the air conditioner belt (4) and remove the compressor (1) mounting screw.
3. Remove the recovery tank (6) and window washer tank (7).
4. Disconnect the air cleaner hose (8).
5. Disconnect the recovery tank hose (5).
6. Disconnect the radiator upper hose (3).
7. Remove the oil cooler mounting screw. (HST model only)
8. Remove the battery (10).
9. Remove the battery stay mounting bolt.
10. Take out the compressor (1), condenser (11), receiver (12), hoses (13), battery stay (9) and etc. as a unit.

**(When reassembling)**

- After reassembling the compressor, be sure to adjust the air conditioner belt tension. (See page G-29.)

Tightening torque	Compressor mounting screw	24.5 to 29.4 N·m 2.5 to 3.0 kgf·m 18.1 to 21.7 ft·lbs
	Muffler mounting screw	31.4 to 37.2 N·m 3.2 to 3.8 kgf·m 23.1 to 27.5 ft·lbs

- |                          |                           |
|--------------------------|---------------------------|
| (1) Compressor           | (8) Air Cleaner Hose      |
| (2) Muffler              | (9) Battery Stay          |
| (3) Radiator Upper Hose  | (10) Battery              |
| (4) Air Conditioner Belt | (11) Condenser            |
| (5) Recovery Tank Hose   | (12) Receiver             |
| (6) Recovery Tank        | (13) Air Conditioner Hose |
| (7) Window Washer Tank   |                           |

W1063451

**Cabin Assembly**

1. Remove the outer roof of cabin.
2. Support the cabin with nylon straps (1) and hoists.
3. Loosen and remove the cabin mounting bolts (2) and nuts (9).
4. Dismounting the cabin from tractor body.

**NOTE**

- Lift the cabin while making sure it does not catch on anything.

**(When reassembling)**

- Be sure to install the washers and mount rubbers, etc. in their original positions.
- Before mounting the cabin, be sure to set both the shuttle lever rod and the shuttle arm to the neutral position, and then connect the shuttle lever rod securely. (GST model)

Tightening torque	Cabin mounting bolt and nut	124 to 147 N·m 12.6 to 15.0 kgf·m 91.1 to 108 ft·lbs
-------------------	-----------------------------	--

- |                        |                       |
|------------------------|-----------------------|
| (1) Nylon Straps       | (7) Washer            |
| (2) Bolt               | (8) Spring Washer     |
| (3) Plate              | (9) Nut               |
| (4) Mount Rubber       |                       |
| (5) Collar             | <b>F : Front Side</b> |
| (6) Plain Washer (M14) | <b>R : Rear Side</b>  |

W1063848



## [2] COMPRESSOR

### (1) Checking



#### Operation of Magnetic Clutch

1. Start the engine.
2. Check whether abrasion or abnormal noise is heard when only the magnetic clutch pulley is running while the A/C switch is pushed **OFF**.
3. Check that the magnetic clutch (1) does not slip when the A/C switch and blower switch are turned **ON** (when the air conditioner is in operation).
4. If anything abnormal is found, repair or replace.

(1) Magnetic Clutch

W1014211

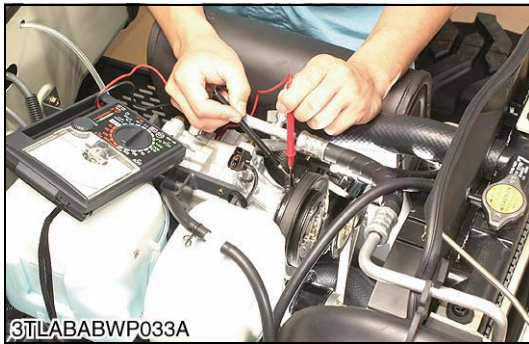

#### Stator Coil

1. Measure the resistance of the stator coil with an ohmmeter across the **2P** connector.
2. If the measurement is not within the factory specifications, replace the stator coil.

Stator coil resistance	Factory spec.	3.0 to 3.4 Ω
------------------------	---------------	--------------

W1014331

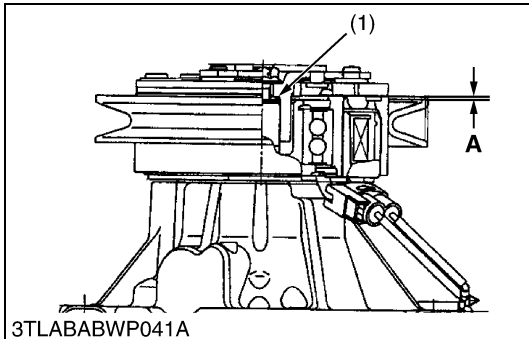

#### Checking Air-gap

1. Measure the air-gap with a feeler gauge.
2. If the measurement is not within the factory specification, adjust the air-gap shim (see page 10-S31).

Air-gap	Factory spec.	0.20 to 0.45 mm 0.008 to 0.018 in.
---------	---------------	---------------------------------------

(1) Shim

A : Air-Gap

W1028014

### (2) Disassembling and Assembling



#### Battery, Front Grill, Skirt and Bonnet

1. Open the bonnet and disconnect the battery negative cable.
2. Disconnect the head light connector and remove the front grill (4).
3. Remove the left and right side skirts (3).
4. Disconnect window washer hoses (2).
5. Remove the bonnet (1).

#### ■ NOTE

- When disconnecting the battery cords, disconnect the negative cord first, when connecting, positive cord first.

(1) Bonnet

(3) Skirt

(2) Window Washer Hose

(4) Front Grill

W1064077

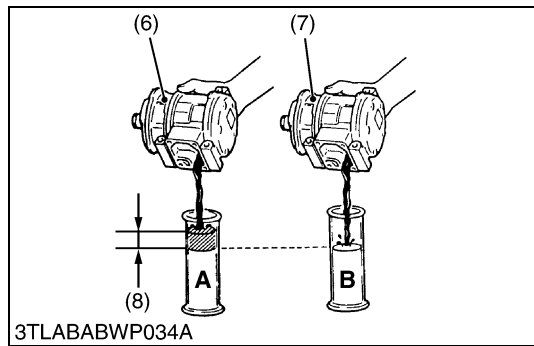
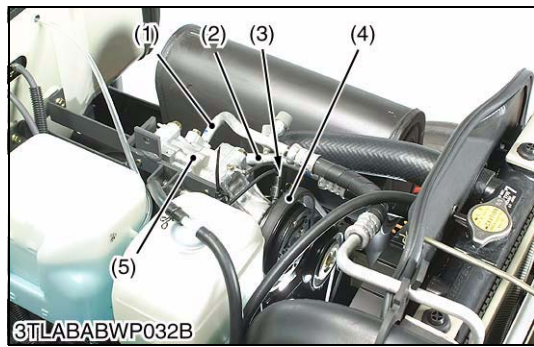

### Compressor

1. Discharge the refrigerant from the system. (Refer to “Discharging the System” : See page 10-S17.)
2. Disconnect the low pressure pipe (suction) (2) and high pressure pipe (discharge) (1) from the compressor, then cap the open fittings immediately to keep moisture out of the system.
3. Disconnect the **2P** connector (3) of magnetic clutch.
4. Remove the air conditioner belt (4) and remove the compressor (5).

#### (When reassembling)

- After reassembling the compressor, be sure to adjust the air conditioner belt tension (see page G-29) and recharge the refrigerant to the system. (Refer to “Charging the System” : See page 10-S19.)
- Apply compressor oil (**DENSO.CO. ND-OIL8** or equivalent) to the O-rings and take care not to damage them.

#### (When replacing compressor)

- When replacing the compressor with a new one, meet the oil amount with old one.

Tightening torque	High pressure pipe and low pressure pipe mounting screw	7.9 to 11.8 N·m 0.81 to 1.20 kgf·m 5.8 to 8.7 ft-lbs
	Compressor mounting screws	24.5 to 29.4 N·m 2.5 to 3.0 kgf·m 18.1 to 21.7 ft-lbs

- |                          |                                 |
|--------------------------|---------------------------------|
| (1) High Pressure Pipe   | (5) Compressor                  |
| (2) Low Pressure Pipe    | (6) New Compressor              |
| (3) <b>2P</b> Connector  | (7) Old Compressor              |
| (4) Air-conditioner Belt | (8) Remove the Excess Oil (A-B) |

W1014469

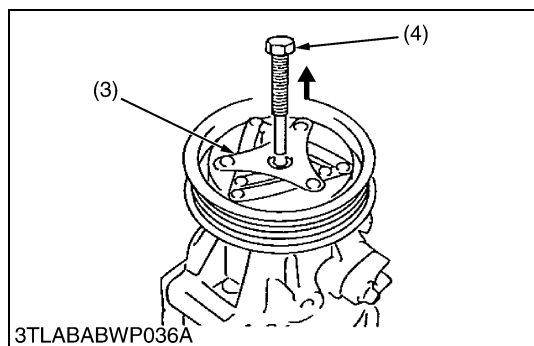
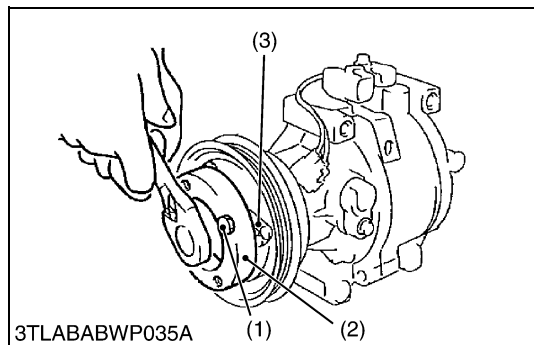

### Hub Plate

1. Three stopper bolts (1) are set in stopper magnet clutch (2) at the position corresponding to the shape of compressor. (See page G-52.)
2. The stopper magnet clutch (2) is hung on hub plate (3) and it is fixed that the compressor rotates.
3. Remove the magnet clutch mounting screw or nut.
4. Remove the hub plate (3).
  - Compressor is used remover magnet clutch (4). (See page G-52.)
5. Remove the shims.

#### (When reassembling)

- Do not apply grease or oil on the hub plate facing.
- Do not use the screw or nut again.
- It is confirmed to turn rotor by hand after assembling and not contact with stator.
- Check and adjust the air gap before tight the magnet clutch mounting screw or nut to the specified torque.

Tightening torque	Clutch mounting screw	10.8 to 16.2 N·m 1.10 to 1.65 kgf·m 8.0 to 11.9 ft-lbs
-------------------	-----------------------	--

- |                           |                           |
|---------------------------|---------------------------|
| (1) Stopper Bolt          | (3) Hub Plate             |
| (2) Stopper Magnet Clutch | (4) Remover Magnet Clutch |

W1059166



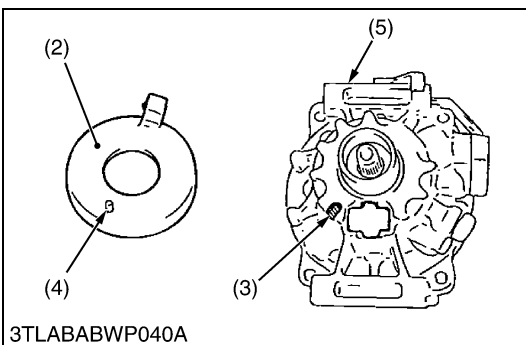
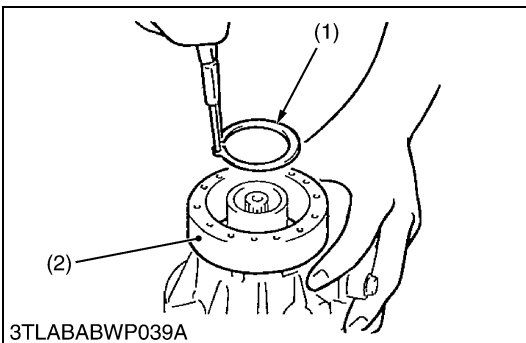
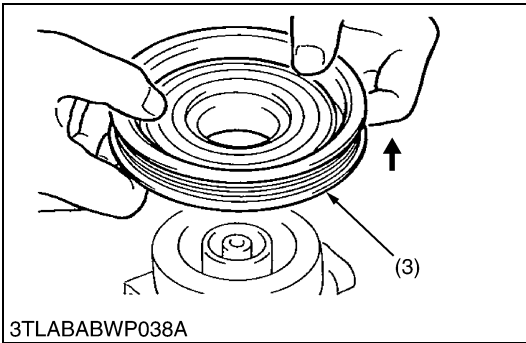
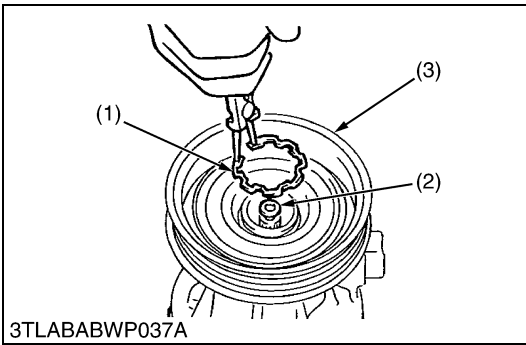

### Rotor

1. Remove the cir-clip (1).
2. Remove the rotor (3).

#### (When reassembling)

- Do not use the cir-clip again.
- Assemble the cir-clip for the tapered side to become outside of rotor.
- The width of expanding of cir-clip is set in boss of shaft as a minimum.

#### (Reference)

Type of compressor	Code No. for circlip
Scroll type	T1065-87450

- (1) Cir-Clip  
(2) Shim

(3) Rotor

W1059753

### Stator

1. Remove the lead wire from compressor body.
2. Remove the external circlip (1).
3. Remove the stator (2).

#### (When reassembling)

- Do not use the cir-clip again.
- Assemble the cir-clip for the tapered side to become outside of front housing.
- The width of expanding of cir-clip is set is boss of shaft as a minimum.
- Match and assemble the concave part (3) of the front housing (5) and the pin (4) of stator.

- (1) External Circlip  
(2) Stator  
(3) Concave Part

(4) Pin  
(5) Front Housing

W1059953

### (3) Servicing

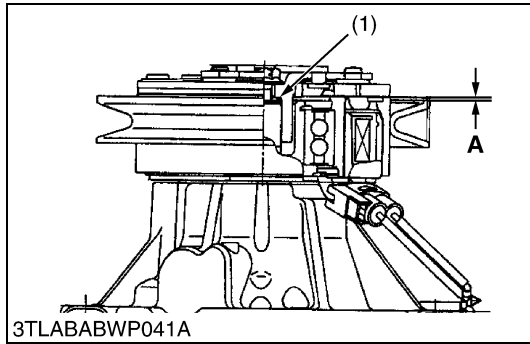

#### Adjustment of Air-gap

1. Measure the air-gap with a feeler gauge.
2. When the measurement value comes off from factory specification, adjustment shim is added or deleted.

Air-gap	Factory spec.	0.20 to 0.45 mm 0.008 to 0.018 in.
---------	---------------	---------------------------------------

#### (Reference)

	Adjustment shim
0.10 mm (0.0039 in.)	T1065-87340
0.15 mm (0.0059 in.)	T1065-87350
0.40 mm (0.016 in.)	T1065-87360
0.60 mm (0.024 in.)	T1065-87370
1.0 mm (0.0394 in.)	T1065-87380

(1) Shim

A : Air-Gap

W1060178

## [3] AIR CONDITIONER SYSTEM AND FRONT WINDSHIELD WIPER

### (1) Checking

#### (A) Air Conditioner Unit

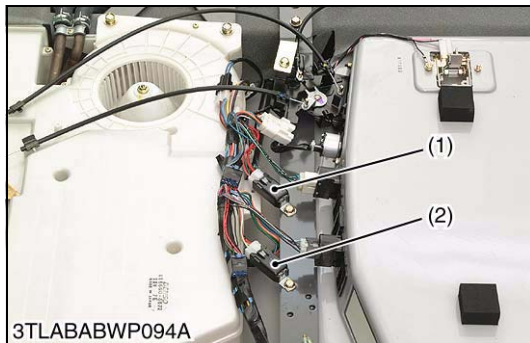

#### A/C Blower Relay and Compressor Relay

1. Remove the outer roof of cabin, and disconnect the relay connectors.
2. Perform the following checkings **1)** and **2)**.

(1) A/C Blower Relay

(2) Compressor Relay

W1016913

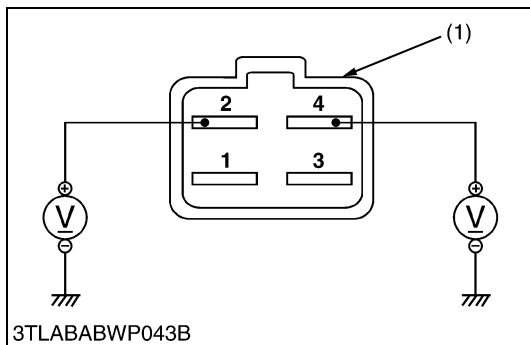

#### 1) Connector Voltage

##### a) A/C Blower Relay

1. The voltage between the terminal **4** and chassis should be approx. battery voltage.
2. When turning the main switch **ON** and A/C blower switch to **LO** position, the voltage between the terminal **2** and chassis should be approx. battery voltage.

##### b) Compressor Relay

1. The voltage between the terminal **4** and chassis should be 0 V.
2. When turning the main switch **ON**, A/C blower switch to **LO** and A/C switch **ON**, the voltage between the terminal **2** and chassis should be approx. battery voltage.

(1) Connector Side

W1017012

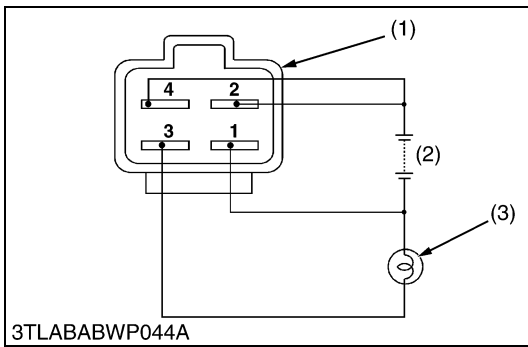

## 2) Relay Test

1. Remove the relay (1).
2. Connect the battery (2) and bulb (3) with the relay (1) as shown in the left figure.
3. In this condition, the bulb should light on if the relay is proper.
4. If the bulb light off when disconnecting the jumper lead from the relay terminal 2, the relay is proper.

- (1) Relay (3) Bulb  
 (2) Battery

W1017314

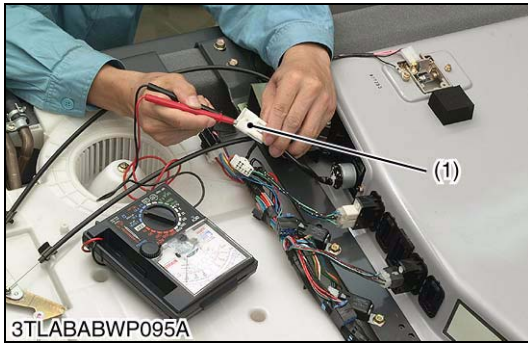

## A/C Blower Switch

1. Remove the outer roof and disconnect the A/C blower switch connector (1).
2. Perform the following checkings 1) and 2).

- (1) A/C Blower Switch Connector

W1017559

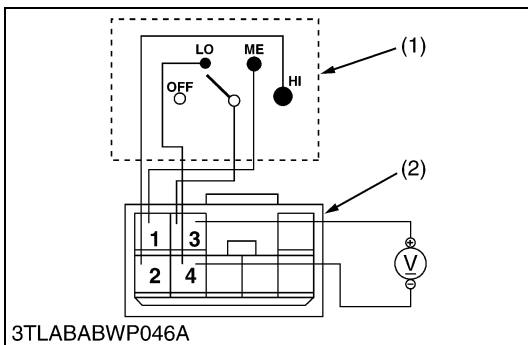

## 1) Connector Voltage

1. Turn the main switch ON.
2. Measure the voltage with a voltmeter between the connector terminal 4 and terminal 3.
3. If the voltage differs from the battery voltage, the wiring harness, A/C relay, fuse or main switch is faulty.

Voltage	Terminal 4 – Terminal 3	Approx. battery voltage
---------	-------------------------	-------------------------

## 2) A/C Blower Switch

1. Check the continuity through the switch with an ohmmeter.
2. If the continuity specified below are not indicated, the switch is faulty.

Position		Terminal			
		3	4	1	2
A/C blower switch	OFF	●			
	● (Low)	●	●		
	● (Medium)	●	●	●	
	● (High)	●	●		●

- (1) A/C Blower Switch

- (2) A/C Blower Switch Connector

W1017851

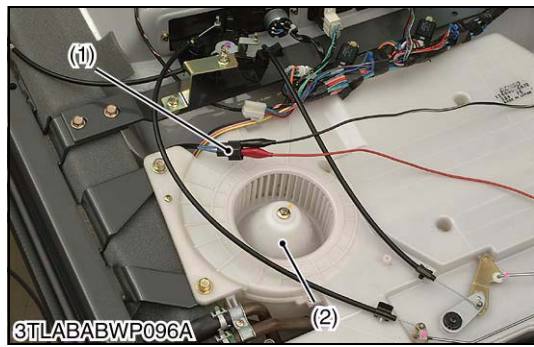

### A/C Blower Motor Test

1. Remove the outer roof.
2. Turn the blower motor (2) by hand and check whether it turns smoothly.
3. Disconnect the connector (1) of blower motor (2).
4. Connect a jumper lead from battery (3) positive terminal to terminal **B**.
5. Connect a jumper lead from battery negative terminal to terminal **E** momentarily.
6. If the blower motor does not run, check the motor.

- (1) Blower Motor Connector                      (3) Battery (12 V)  
 (2) Blower Motor

W1018829

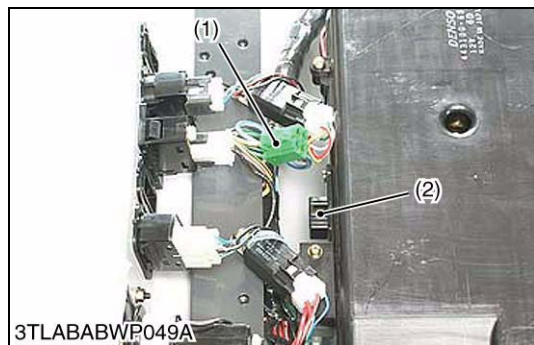
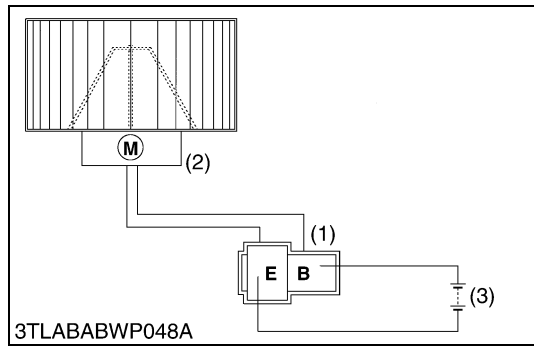

### A/C Blower Resistor

1. Remove the outer roof.
2. Disconnect the **4P** connector (1) for A/C blower resistor (2).
3. Measure the resistance with an ohmmeter across the terminal **Me** and terminal **Hi**, and across the terminal **Lo** and terminal **Hi**.
4. If the factory specifications are not indicated, A/C blower resistor is faulty.

Resistance	Factory spec.	Terminal <b>Me</b> – Terminal <b>Hi</b>	Approx. 0.7 Ω
		Terminal <b>Lo</b> – Terminal <b>Hi</b>	Approx. 1.5 Ω

- (1) A/C Blower Resistor Connector              (2) A/C Blower Resistor

W1019107

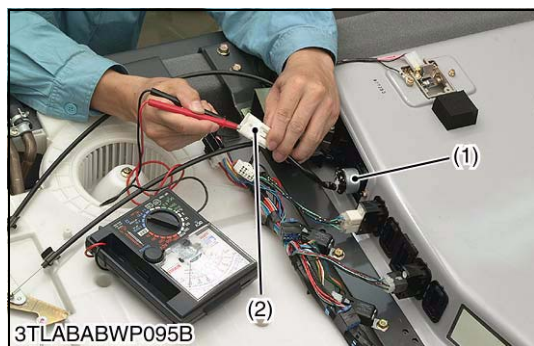
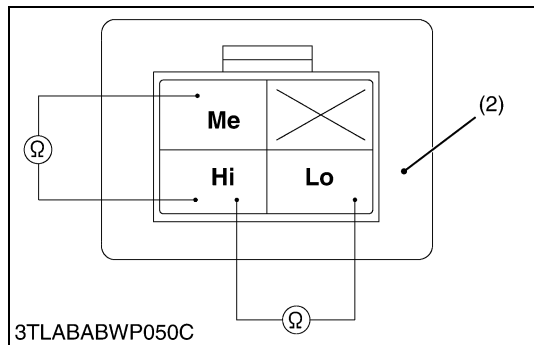

### A/C Switch

1. Remove the outer roof, and disconnect the A/C switch connector (2).
2. Perform the following checkings **1)** and **2)**.

- (1) A/C Switch    (2) A/C Switch Connector

W1019584

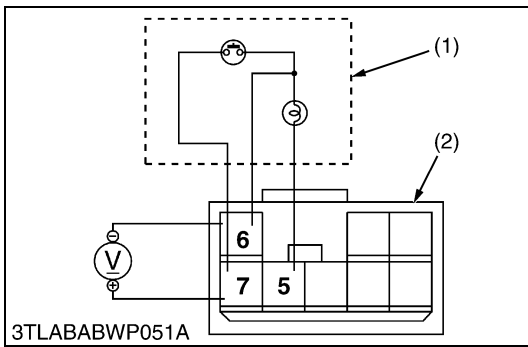

### 1) Connector Voltage

1. Turn the main switch **ON**.
2. Measure the voltage with a voltmeter between the terminal **7** and terminal **6**.
3. If the voltage differs from the battery voltage, the wiring harness, A/C relay or fuse is faulty.

### 2) A/C Switch

1. Check the continuity through the switch with an ohmmeter.
2. If the continuity specified below is not indicated, the switch is faulty.

Position \ Terminal		7	6	5
		A/C switch		
	<b>OFF</b> *2			
	<b>ON</b> *1	●—	●—	

\*1 : Push the A/C switch button to **ON** position.

\*2 : Push again the A/C switch button to **OFF** position.

(1) A/C Switch

(2) A/C Switch Connector

W1019763



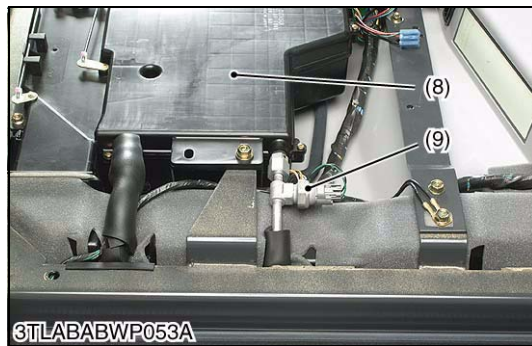
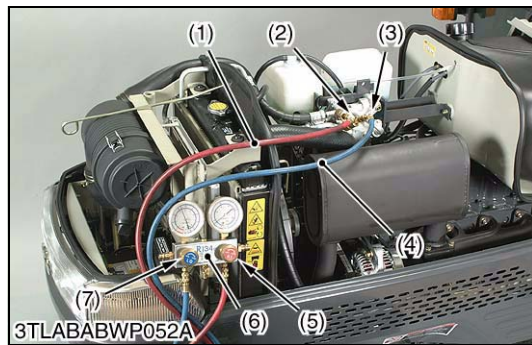

## Pressure Switch

### 1) HI Pressure Side

1. Connect the manifold gauge (6) to compressor as following procedure.  
Close the **HI** and **LO** pressure valves (5), (7) of manifold gauge tightly, and connect the charging hoses (red and blue) (1), (4) to the respective compressor service valves. (Refer to **HANDLING OF SERVICE TOOLS** : See page 10-S9.)

#### ■ NOTE

- **Be sure to drive out the air in the charging hoses at the manifold gauge connection end by utilizing the refrigerant pressure in the refrigerant cycle.**
2. Start the engine and set at approx. 1500 min<sup>-1</sup> (rpm). Turn on the A/C switch, then set the blower switch to **HI** position.
  3. Raise pressure on the **HI** pressure side of the refrigerant cycle by covering the condenser front with a corrugated carboard, and the pressure switch (9) is activated and the compressor magnetic clutch is turned off. At this time, read the **HI** pressure gauge of the manifold gauge. If this pressure reading differs largely with the setting pressure, replace the pressure switch with a new one.

Setting pressure	Factory spec.	Pressure switch <b>OFF</b>	More than approx. 3.14 MPa 32 kgf/cm <sup>2</sup> 455 psi
------------------	---------------	-------------------------------	--

### 2) LO Pressure Side

1. Disconnect **2P** connector of pressure switch.
2. Measure the resistance with an ohmmeter across the connector terminals.
3. If 0 ohm is not indicated at normal condition, there is no refrigerant in the refrigerating cycle because gas leaks or pressure switch is defective.

#### (Reference)

Setting pressure	Factory spec.	Pressure switch <b>OFF</b>	Less than approx. 0.196 MPa 2.0 kgf/cm <sup>2</sup> 28.4 psi
------------------	---------------	-------------------------------	---

- The resistance of pressure switch is 0 ohm in normal running, but is becomes infinity if the pressure is abnormal (out of factory spec.). Because the pressure switch starts to work.

- |   |                              |
|---|------------------------------|
| (1) Charging Hose (Red)                           | (5) <b>HI</b> Pressure Valve |
| (2) <b>HI</b> (High Pressure Side) Charging Valve | (6) Manifold Gauge           |
| (3) <b>LO</b> (Low Pressure Side) Charging Valve  | (7) <b>LO</b> Pressure Valve |
| (4) Charging Hose (Blue)                          | (8) Air Conditioner Unit     |
|   | (9) Pressure Switch          |

W1020509

## Defogger Switch

1. Remove the outer roof and disconnect the defogger switch connector (1).
2. Perform the following checkings **1)** and **2)**.

- |                               |                     |
|-------------------------------|---------------------|
| (1) Defogger Switch Connector | (2) Defogger Switch |
|-------------------------------|---------------------|

W1015868

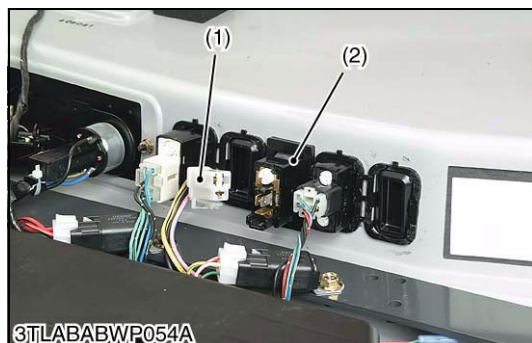



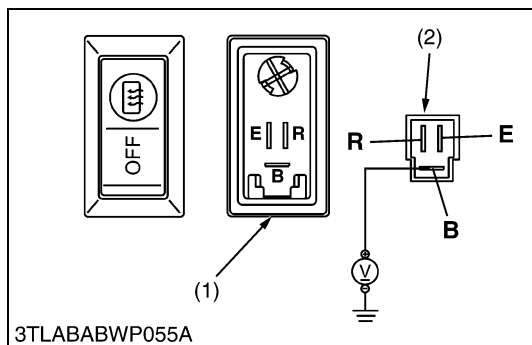

**1) Connector Voltage**

1. Turn the main switch **ON**.
2. Measure the voltage with a voltmeter between the terminal **B** and chassis.
3. If the voltage differs from the battery voltage, the wiring harness, fuse or main switch is faulty.

Voltage	Terminal <b>B</b> – Chassis	Approx. battery voltage
---------	-----------------------------	-------------------------

**2) Defogger Switch**

1. Check the continuity through the switch with an ohmmeter.
2. If the continuity specified below are not indicated, the switch is faulty.

	<b>T</b>	<b>B</b>	<b>R</b>	<b>E</b>
<b>P</b>				
<b>ON</b>		●	●	●
<b>OFF</b>			●	●

(1) Defogger Switch Side

(2) Connector Side

W1015953

**(B) Front Windshield Wiper**

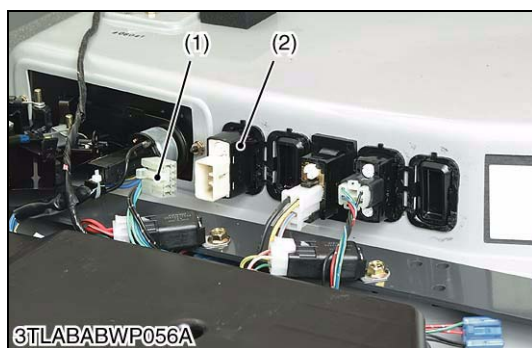

**Front Wiper Switch**

1. Remove the outer roof, and disconnect the front wiper switch connector (1).
2. Perform the following checkings **1) and 2)**.

(1) Front Wiper Switch Connector

(2) Front Wiper Switch

W1021780

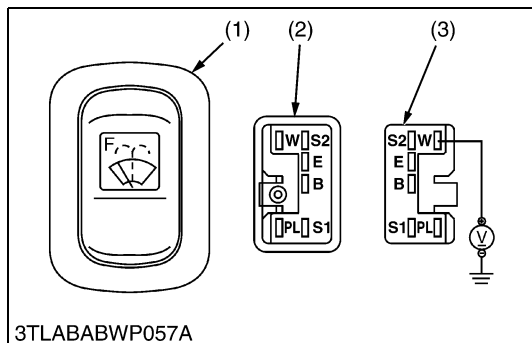

**1) Connector Voltage**

1. Turn the main switch **ON**.
2. Measure the voltage with a voltmeter between the terminal **W** and chassis.
3. If the voltage differs from the battery voltage, the wiring harness, fuse or main switch is faulty.

Voltage	Terminal <b>W</b> – Chassis	Approx. battery voltage
---------	-----------------------------	-------------------------

**2) Front Wiper Switch**

1. Check the continuity through the switch with an ohmmeter.
2. If continuity specified below is not indicated, the switch is faulty.

	Terminal	<b>S1</b>	<b>S2</b>	<b>B</b>	<b>W</b>	<b>E</b>	<b>PL</b>
Front wiper switch	<b>WASH I</b>				●	●	
	<b>OFF</b>	●	●				
	<b>ON</b>		●	●			
	<b>WASH II</b>		●	●	●	●	

**(Reference)**

- **WASH I** : **OFF** side of the wiper switch remains pushed in.
- **WASH II** : **ON** side remains pushed in after the wiper switch is switched **ON** and remains switched **ON**.

(1) Front Wiper Switch

(3) Front Wiper Switch Connector

(2) Front Wiper Switch Connector (Switch Side)

(Wiring Harness Side)

W1021874

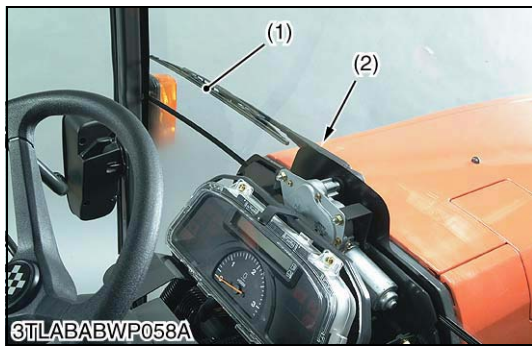

**Front Wiper Motor**

1. Raise up the front wiper arm (2).
2. Turn the main switch **ON**.
3. Push the front wiper switch to **ON** position.
4. Count the number of wiper arm rocking per minutes.
5. If the number differs from the factory specifications, replace the wiper motor assembly.

No load rotating speed	Factory spec.	33 to 43 min <sup>-1</sup> (rpm)
------------------------	---------------	----------------------------------

- (1) Wiper Blade (2) Wiper Arm

W1022632

**(C) Rear Windshield Wiper**

**Rear Wiper Switch (If Equipped)**

1. Remove the outer roof, and disconnect the rear wiper switch connector (1).
2. Perform the following checkings **1)** and **2)**.

- (1) Rear Wiper Switch Connector (Option)

W1030973

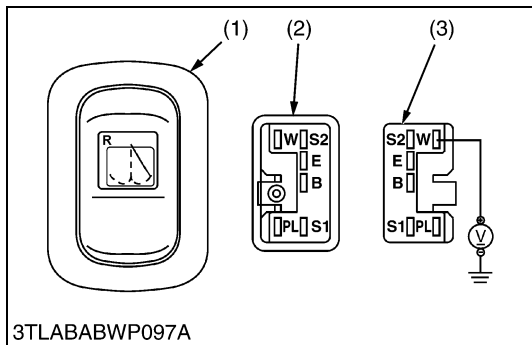

**1) Connector Voltage**

1. Turn the main switch **ON**.
2. Measure the voltage with a voltmeter between the terminal **W** and chassis.
3. If the voltage differs from the battery voltage, the wiring harness, fuse or main switch is faulty.

Voltage	Terminal <b>W</b> – Chassis	Approx. battery voltage
---------	-----------------------------	-------------------------

**2) Front Wiper Switch**

1. Check the continuity through the switch with an ohmmeter.
2. If continuity specified below is not indicated, the switch is faulty.

Position		Terminal	S1	S2	B	W	E	PL
Rear wiper switch	WASH I					●	●	
	↑↓		×		×			
	OFF		●	●				
	↑↓		×		×			
	ON			●	●			
	↑↓		×		×			
WASH II			●	●		●	●	

**(Reference)**

- **WASH I** : **OFF** side of the wiper switch remains pushed in.
- **WASH II** : **ON** side remains pushed in after the wiper switch is switched **ON** and remains switched **ON**.

- (1) Rear Wiper Switch (2) Rear Wiper Switch Connector (Switch Side) (3) Rear Wiper Switch Connector (Wiring Harness Side)

W1031110

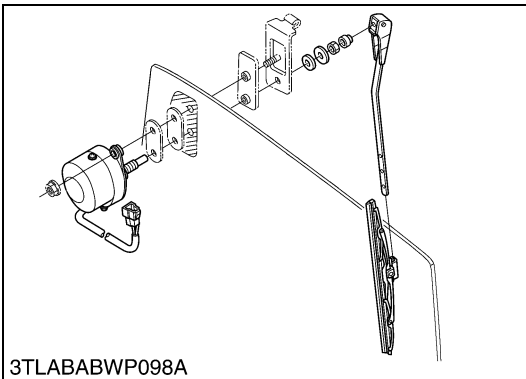

### Rear Wiper Motor

1. Raise up the rear wiper arm (2).
2. Turn the main switch **ON**.
3. Push the rear wiper switch to **ON** position.
4. Count the number of wiper arm rocking per minutes.
5. If the number differs from the factory specifications, replace the wiper motor assembly.

No load rotating speed	Factory spec.	49 to 61 min <sup>-1</sup> (rpm)
------------------------	---------------	----------------------------------

(1) Wiper Blade

(2) Wiper Arm

W1031594

## (2) Disassembling and Assembling

### (A) Removing Air Conditioner Unit

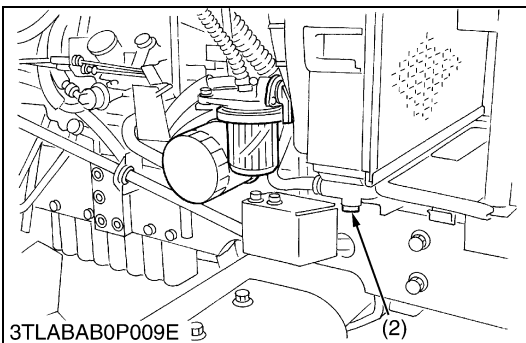
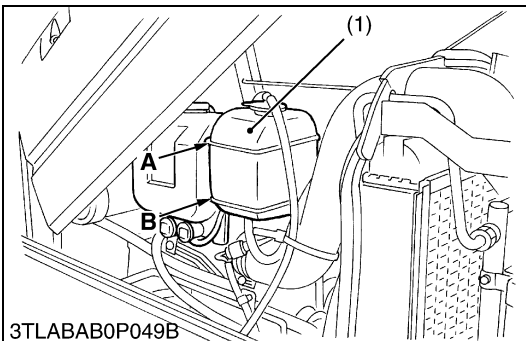

### Draining Coolant

#### ⚠ CAUTION

- Never remove the radiator cap until coolant temperature is well below its boiling point. Then loosen cap slightly to the stop to relieve any excess pressure before removing cap completely.

1. Stop the engine and let cool down.
2. Loosen the drain plug (2) to drain the coolant.
3. Remove the radiator cap to completely drain the coolant.
4. After all coolant is drained, retighten the drain plug (2).

#### (When refilling)

- Fill the coolant between the “**FULL**” and “**LOW**” marks of recovery tank (1).

Coolant capacity (with recovery tank)	L5030	9.2 L 9.7 U.S.qts 8.1 Imp.qts
---------------------------------------	-------	-------------------------------------

(1) Recovery Tank

**A : FULL**

(2) Drain Plug

**B : LOW**

W10646580

### Discharging Refrigerant

1. Refer to “Discharging the System”. (See page 10-S17.)

W1023185

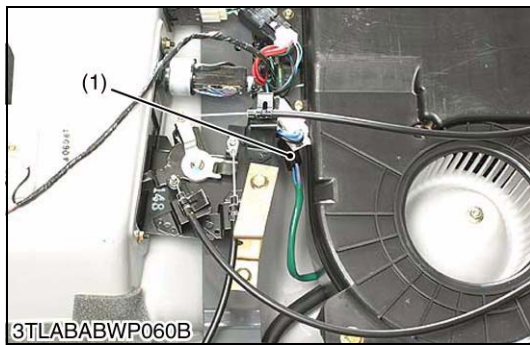

### Blower Motor and Blower Resistor

1. Remove the outer roof.
2. Disconnect the battery negative cable.
3. Disconnect the A/C blower motor connector (1).
4. Disconnect the A/C blower resistor connector (2) for A/C blower resistor (3).

(1) A/C Blower Motor Connector  
 (2) A/C Blower Resistor Connector

(3) A/C Blower Resistor

W1023280

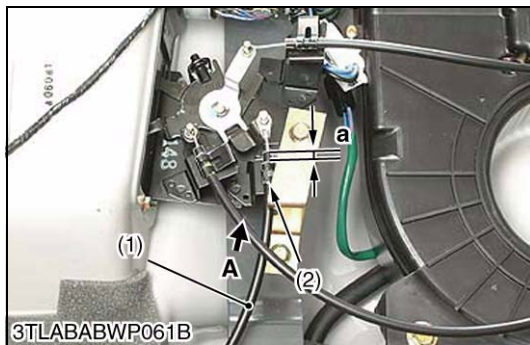
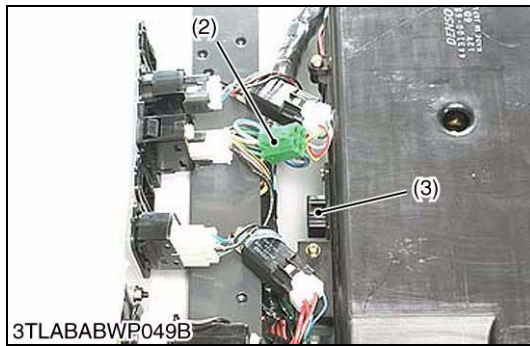

### Water Valve Control Cable (White Tape)

1. When disconnecting the water valve cable (1), follow the next reassembly procedure.

#### (When reassembling)

- Fully close the water valve (3) and reconnect the cable (1).
- Set the control at **MAX COOL** position. Fit the inner cable in position, and press and fix the outer cable by the cable clip (2) in the direction of arrow (**A**) as shown at left.
- Move the temperature control lever several times to make sure the water valve is fully closed at **MAX COOL** position.
- Do not allow the water valve cable to bend just away from the control, nor to get caught by the outer roof.

(1) Water Valve Control Cable  
 (2) Cable Clip  
 (3) Water Valve

a : 5 to 10 mm (0.20 to 0.40 in.)

A : Direction of Pulling Outer Cable

W1023983

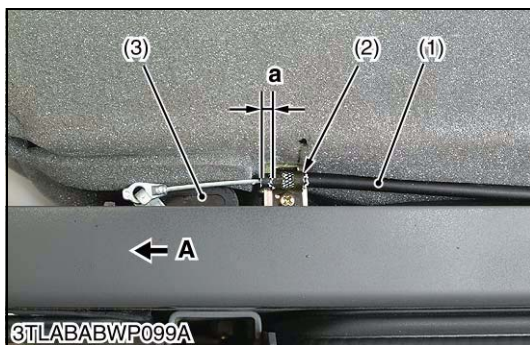



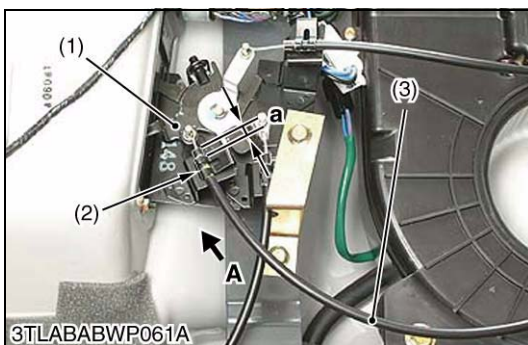
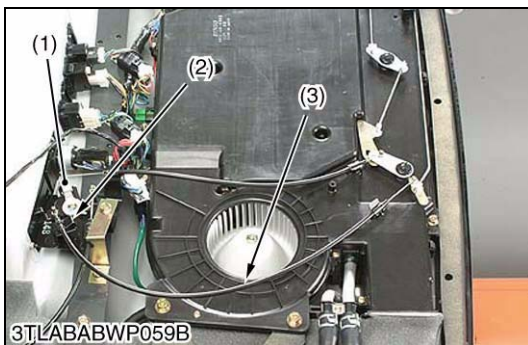
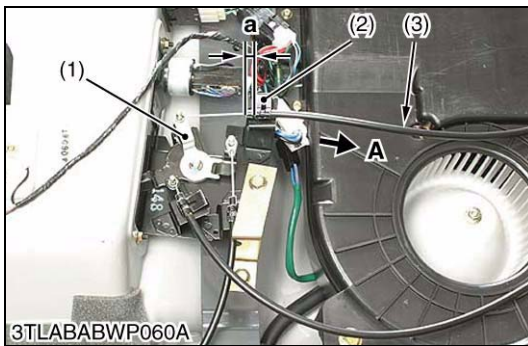
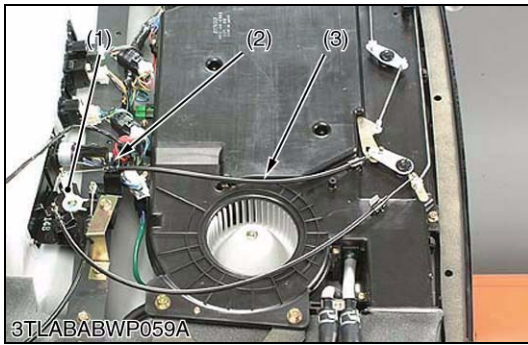

### Air Mixing Door Control Cable (Blue Tape)

1. Disconnect the air mixing door control cable (3) from the damper lever (1) of air conditioner control panel side.

#### **(When reassembling)**

- Set the damper lever (1) of the air conditioner unit at **MAX HOT** position. Reconnect the cable.
- Move the control to **MAX HOT** position. Fit the inner cable in position, and press and fix the outer cable by the cable clip (2) in the direction of arrow (**A**) as shown at left.
- Move the temperature control lever several times and finally set it to **MAX HOT** position to make sure the damper lever is at **HOT** position too.

- (1) Damper Lever  
 (2) Cable Clip  
 (3) Air Mixing Door Control Cable

a : 5 to 10 mm (0.20 to 0.40 in.)

A : Direction of Pulling Outer Cable

W1023417

### A/C Mode Door Control Cable (Yellow Tape)

1. Disconnect the air conditioner mode door control cable (3) from the defrosting (**DEF**) position control lever (1) of A/C control panel side.

#### **(When reassembling)**

- Set the air conditioner unit to **DEF** mode position and reconnect the cable (3).
- Set the control at **DEF** position. Fit the inner cable in position, and press and fix the outer cable by the cable clip (2) in the direction of arrow (**A**) as shown at left.
- Move the mode lever several times and finally set it to **DEF** position to make sure to air conditioner unit is at defrosting (**DEF**) mode position.
- Lay and fix the mode door control cable over the water valve cable.

- (1) DEF. Control Lever  
 (2) Cable Clip  
 (3) Mode Door Control Cable

a : 5 to 10 mm (0.20 to 0.40 in.)

A : Direction of Pulling Outer Cable

W1023759

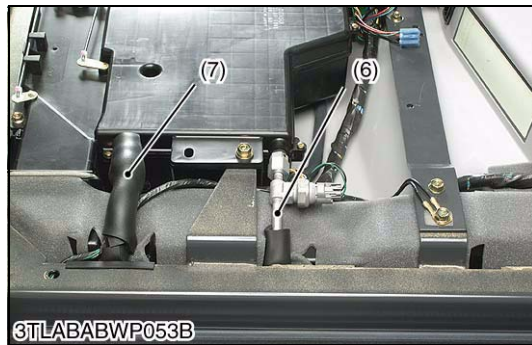
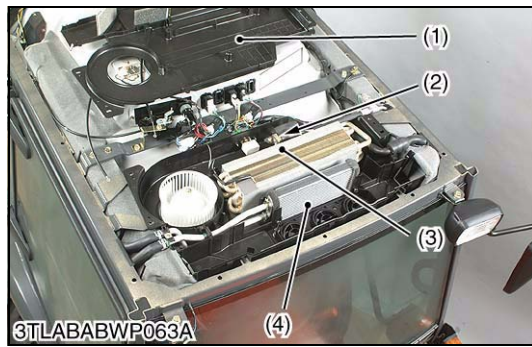

### Air Conditioning Unit

1. Remove the unit cover (1).
2. Disconnect the heater hoses (5).
3. Disconnect the cooler pipe (liquid) (6) and cooler pipe (suction side) (7).
4. Remove the screws and take off the unit.
5. Remove the duct hoses.

#### (When reassembling)

- When reconnecting the cooler pipes with the unit, apply compressor oil (DENSO.CO. OIL8 or equivalent) to O-rings.
- When remounting the unit, tighten five screws by hand and finally retighten them after aligning the inner roof duct with the unit duct.
- When connecting the heater hose with A/C unit, hose should be put into the A/C unit pipe more than 30 mm (1.2 in.)

Tightening torque	A/C unit mounting screw (M6)	3.92 to 6.86 N·m 0.40 to 0.70 kgf·m 2.89 to 5.06 ft-lbs
	A/C unit mounting screw (M8)	9.8 to 11.68 N·m 1.00 to 1.19 kgf·m 7.23 to 8.6 ft-lbs
	Low pressure pipe (Cooler pipe (suction)) retaining nut	29.4 to 34.3 N·m 3.0 to 3.5 kgf·m 21.7 to 25.3 ft-lbs
	High pressure pipe (Cooler pipe (liquid)) retaining nut	11.8 to 14.7 N·m 1.2 to 1.5 kgf·m 8.7 to 10.8 ft-lbs

- (1) Unit Cover
- (2) Expansion Valve
- (3) Evaporator
- (4) Heater Core
- (5) Heater Hoses

- (6) High Pressure Pipe (Cooler Pipe (Liquid))
- (7) Low Pressure Pipe (Cooler Pipe (Suction Side))

W1025169



**(B) Wiper Motor**

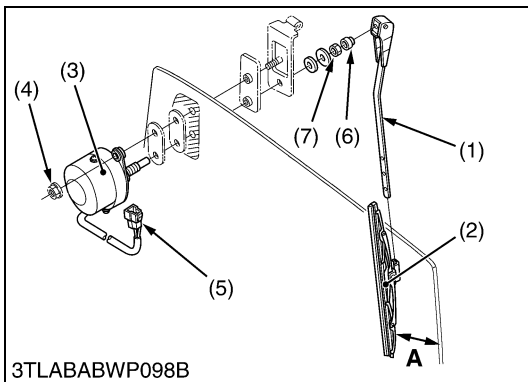
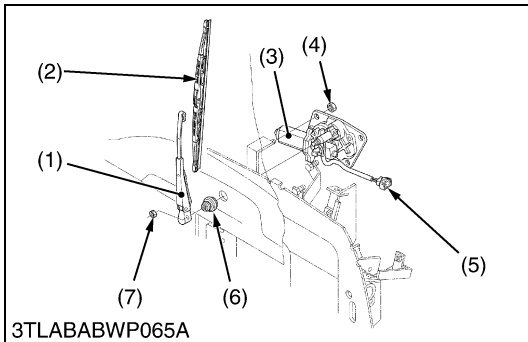
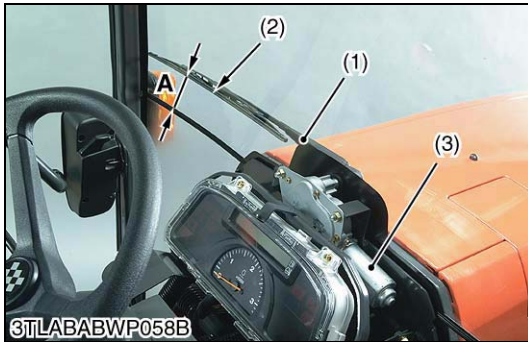

**Front Wiper Motor**

1. Remove the steering post covers and steering post under cover.
2. Remove the meter panel.
3. Remove the panel under cover.
4. Disconnect the front wiper motor **4P** connector (5).
5. Remove the wiper arm mounting nut (7) and wiper arm (1).
6. Remove the wiper link cap (6).
7. Remove the front wiper motor (3).

**(When reassembling)**

- When attaching the wiper arm (1) to the wiper motor (3), assemble so that the dimensions are as given in the photo on the left. After doing so, check if the wiper wipes symmetrically on the left and right (bilateral symmetry).

Tightening torque	Wiper arm mounting nut (7)	6.37 to 9.32 N-m 0.65 to 0.95 kgf-m 4.7 to 6.9 ft-lbs
	Wiper motor mounting nut (4)	2.5 to 3.4 N-m 0.25 to 0.35 kgf-m 1.9 to 2.5 ft-lbs

Distance <b>A</b>	Factory spec.	90 to 110 mm 3.5 to 4.3 in.
-------------------	---------------	--------------------------------

- |                       |   |
|-----------------------|---|
| (1) Wiper Arm         | (5) Front Wiper Motor Connector ( <b>4P</b> ) |
| (2) Wiper Blade       | (6) Wiper Link Cap                            |
| (3) Front Wiper Motor | (7) Nut                                       |
| (4) Nut               |   |

W1025464

**Rear Wiper Motor (If Equipped)**

1. Disconnect the rear wiper motor **3P** connector (5).
2. Remove the wiper arm mounting nut (7) and wiper arm (1).
3. Remove the wiper link cap (6).
4. Remove the rear wiper motor (3).

Tightening torque	Wiper arm mounting nut (7)	4.9 to 6.9 N-m 0.50 to 0.70 kgf-m 3.61 to 5.09 ft-lbs
	Wiper motor mounting nut (4)	4.90 to 5.88 N-m 0.50 to 0.60 kgf-m 3.61 to 4.30 ft-lbs

Distance <b>A</b>	Factory spec.	50 to 70 mm 1.97 to 2.76 in.
-------------------	---------------	---------------------------------

- |                      |  |
|----------------------|--|
| (1) Wiper Arm        | (4) Nut                                      |
| (2) Wiper Blade      | (5) Rear Wiper Motor Connector ( <b>3P</b> ) |
| (3) Rear Wiper Motor | (6) Wiper Link Cap                           |

W1034169

## (C) Removing Air Conditioner Pipes (A/C Model)

### Discharging Refrigerant

1. Refer to “Discharging the System”. (See page 10-S17.)

W1026331



### Battery, Front Grill, Skirt and Bonnet

1. Open the bonnet and disconnect the battery negative cable.
2. Disconnect the head light connector and remove the front grill (4).
3. Remove the left and right side skirts (3).
4. Disconnect window washer hoses (2).
5. Remove the bonnet (1).

#### ■ NOTE

- When disconnecting the battery cords, disconnect the negative cord first, when connecting, positive cord first.

- |                        |                 |
|------------------------|-----------------|
| (1) Bonnet             | (3) Skirt       |
| (2) Window Washer Hose | (4) Front Grill |

W1064975



### High Pressure Pipe 1

1. Disconnect the high pressure pipe 1 (2) from the compressor (1) and condenser (3), then cap the open fittings immediately to keep moisture out of the system.

#### (When reassembling)

- Apply compressor oil (DENSO.CO. ND-OIL 8 or equivalent) to the O-rings and take care not to damage them.

Tightening torque	High pressure pipe 1 mounting screw (Compressor side)	7.8 to 11.8 N-m 0.81 to 1.20 kgf-m 5.8 to 8.7 ft-lbs
	High pressure retaining nut (Condenser side)	19.6 to 24.5 N-m 2.0 to 2.5 kgf-m 14.5 to 18.1 ft-lbs

- |                          |               |
|--------------------------|---------------|
| (1) Compressor           | (3) Condenser |
| (2) High Pressure Pipe 1 |               |

W1026502

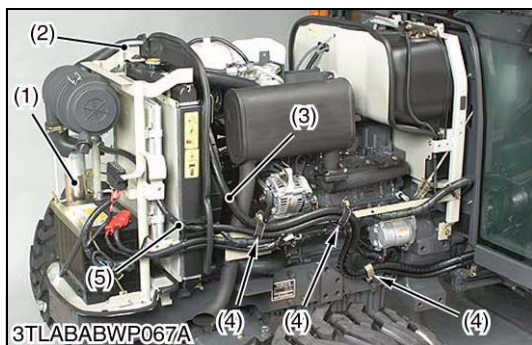

### Hose Clamp

1. Remove the hose clamp (4).
2. Disconnect the high pressure pipe 1 (5) from the receiver (1) and low pressure pipe (3) from the compressor, then cap the open fittings immediately to keep moisture out of the system.

#### (When reassembling)

- Apply compressor oil (DENSO.CO. ND-OIL 8 or equivalent) to the O-rings and take care not to damage them.

Tightening torque	High pressure pipe 2 retaining nut	11.8 to 14.7 N-m 1.2 to 1.5 kgf-m 8.7 to 10.8 ft-lbs
	Low pressure pipe mounting screw (Compressor side)	7.9 to 11.8 N-m 0.81 to 1.20 kgf-m 5.8 to 8.7 ft-lbs

- |                          |                          |
|--------------------------|--------------------------|
| (1) Receiver             | (4) Hose Clamp           |
| (2) High Pressure Pipe 2 | (5) High Pressure Pipe 1 |
| (3) Low Pressure Pipe    |                          |

W1026689

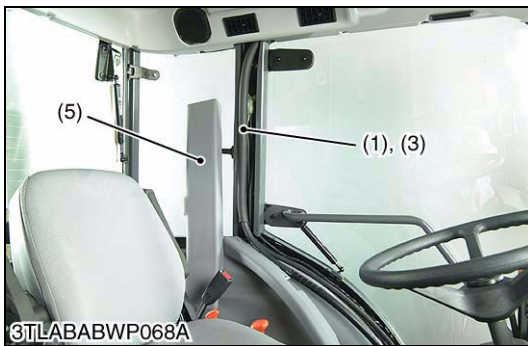
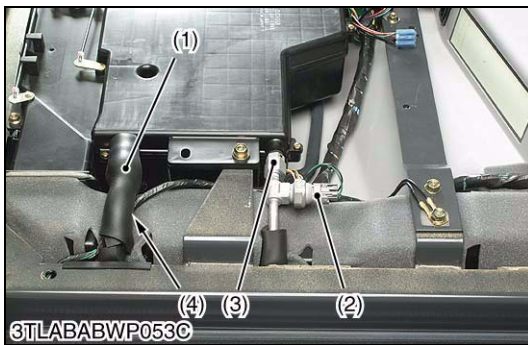

### High Pressure and Low Pressure Pipes

1. Remove the outer roof.
2. Disconnect the pressure switch (2) connector.
3. Disconnect the high pressure pipe 2 (3), then cap the open fitting immediately to keep moisture out of the system.
4. Remove the rubber (4) and disconnect the low pressure pipe (1), then cap the open fittings immediately to keep moisture out of the system.
5. Remove the inner covers (5).

#### (When reassembling)

- Replace the rubber (4) with a new one.
- Apply compressor oil (DENSO.CO. ND-OIL 8 or equivalent) to the O-rings and take care not to damage them.

Tightening torque	High pressure pipe 2 retaining nut	11.8 to 14.7 N·m 1.2 to 1.5 kgf·m 8.7 to 10.8 ft·lbs
	Low pressure pipe retaining nut	29.4 to 34.3 N·m 3.0 to 3.5 kgf·m 21.7 to 25.3 ft·lbs

- (1) Low Pressure Pipe
- (2) Pressure Switch
- (3) High Pressure Pipe 2
- (4) Rubber
- (5) Inner Cover

W1026890

### (D) Removing Heater Unit

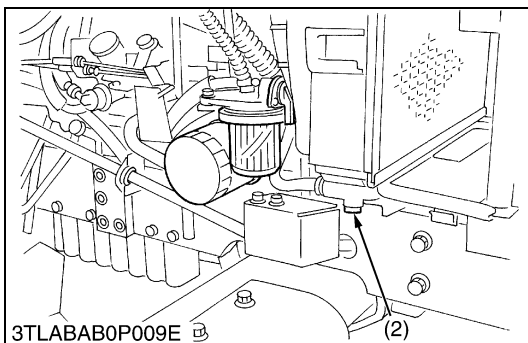
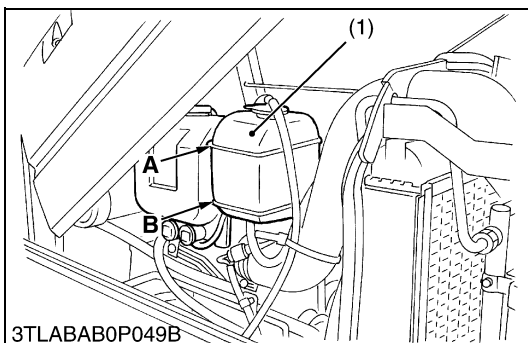

### Draining Coolant

#### ⚠ CAUTION

- **Never remove the radiator cap until coolant temperature is well below its boiling point. Then loosen cap slightly to the stop to relieve any excess pressure before removing cap completely.**

1. Stop the engine and let cool down.
2. Loosen the drain plug (2) to drain the coolant.
3. Remove the radiator cap to completely drain the coolant.
4. After all coolant is drained, retighten the drain plug (2).

#### (When refilling)

- Fill the coolant between the “FULL” and “LOW” marks of recovery tank (1).

Coolant capacity (with recovery tank)	L3830 L4630	8.7 L 9.2 U.S.qts 7.7 Imp.qts
	L5030	9.2 L 9.7 U.S.qts 8.1 Imp.qts

- (1) Recovery Tank
- (2) Drain Plug
- A : FULL**
- B : LOW**

0



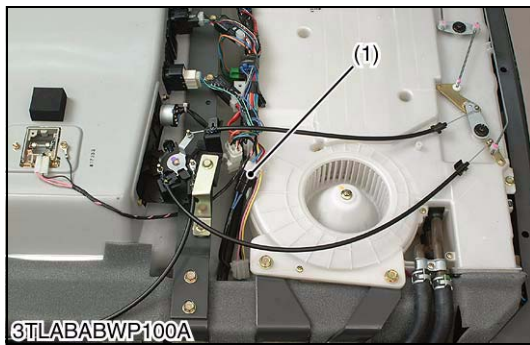

### Blower Motor and Blower Resistor

1. Remove the outer roof.
2. Disconnect the battery negative cable.
3. Disconnect the blower motor connector (1).
4. Disconnect the blower resistor connector (3) for blower resistor (2).

(1) Blower Motor Connector  
(2) Blower Resistor

(3) Blower Resistor Connector

W1035074

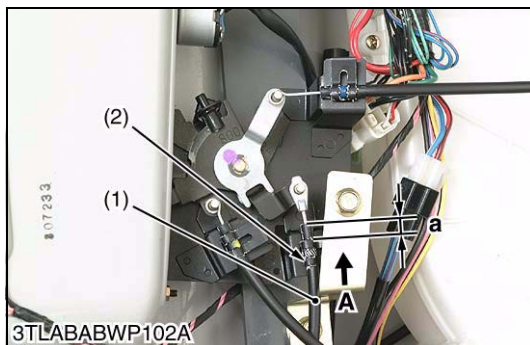
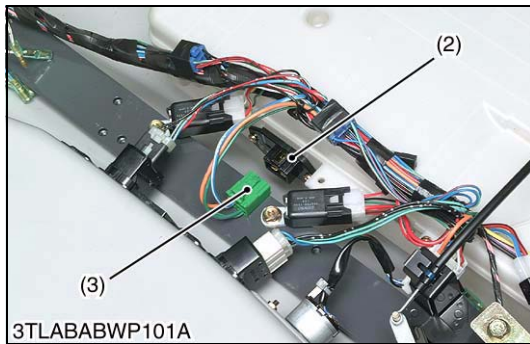

### Water Valve Control Cable (White Tape)

1. When disconnecting the water valve cable (1), follow the next reassembly procedure.

#### **(When reassembling)**

- Fully close the water valve (3) and reconnect the cable (1).
- Set the control at **MAX COOL** position. Fit the inner cable in position, and press and fix the outer cable by the cable clip (2) in the direction of arrow (**A**) as shown at left.
- Move the temperature control lever several times to make sure the water valve is fully closed at **MAX COOL** position.
- Do not allow the water valve cable to bend just away from the control, nor to get caught by the outer roof.

(1) Water Valve Control Cable  
(2) Cable Clip  
(3) Water Valve

a : 5 to 10 mm (0.20 to 0.40 in.)

A : Direction of Pulling Outer Cable

W1035392

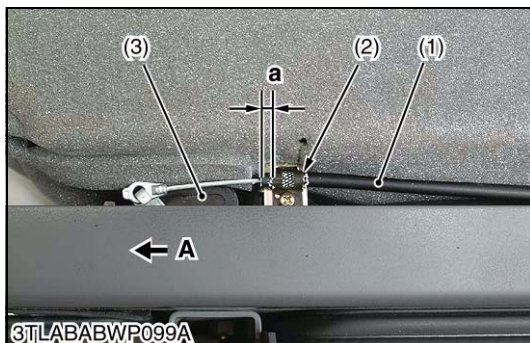

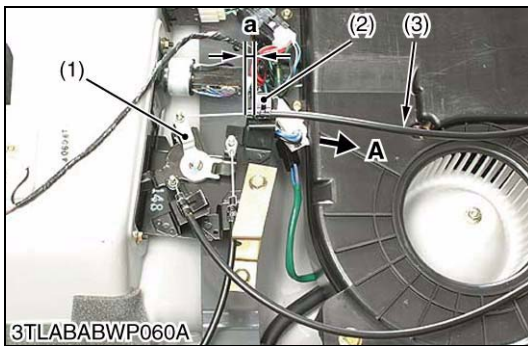
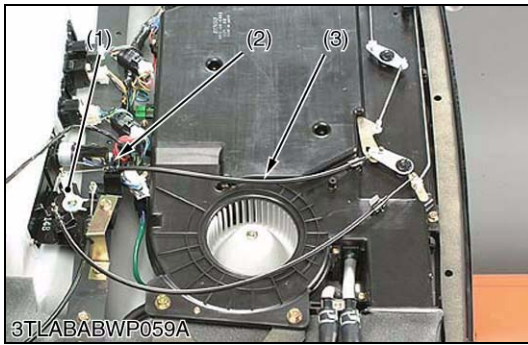

### Air Mixing Door Control Cable (Blue Tape)

1. Disconnect the air mixing door control cable (3) from the damper lever (1) of air conditioner control panel side.

#### (When reassembling)

- Set the damper lever (1) of the air conditioner unit at **MAX HOT** position. Reconnect the cable.
- Move the control to **MAX HOT** position. Fit the inner cable in position, and press and fix the outer cable by the cable clip (2) in the direction of arrow (**A**) as shown at left.
- Move the temperature control lever several times and finally set it to **MAX HOT** position to make sure the damper lever is at **HOT** position too.

- (1) Damper Lever  
 (2) Cable Clip  
 (3) Air Mixing Door Control Cable

a : 5 to 10 mm (0.20 to 0.40 in.)

A : Direction of Pulling Outer Cable

W1035584

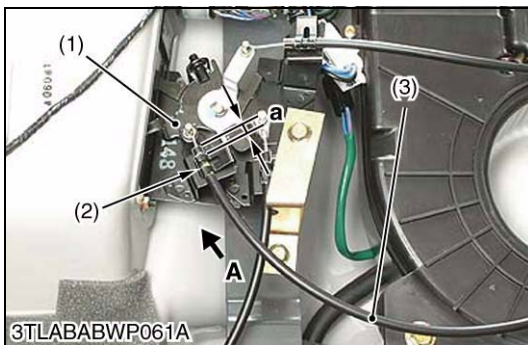
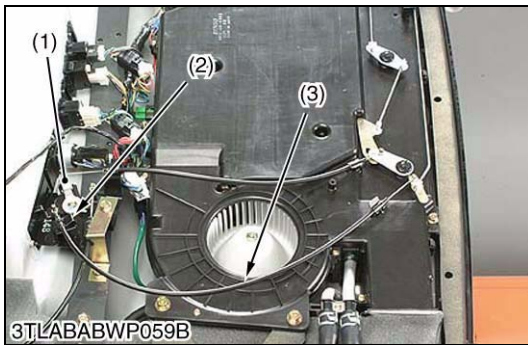

### Mode Door Control Cable (Yellow Tape)

1. Disconnect the air conditioner mode door control cable (3) from the defrosting (**DEF**) position control lever (1) of control panel side.

#### (When reassembling)

- Set the air conditioner unit to **DEF** mode position and reconnect the cable (3).
- Set the control at **DEF** position. Fit the inner cable in position, and press and fix the outer cable by the cable clip (2) in the direction of arrow (**A**) as shown at left.
- Move the mode lever several times and finally set it to **DEF** position to make sure to air conditioner unit is at defrosting (**DEF**) mode position.
- Lay and fix the mode door control cable over the water valve cable.

- (1) DEF. Control Lever  
 (2) Cable Clip  
 (3) Mode Door Control Cable

a : 5 to 10 mm (0.20 to 0.40 in.)

A : Direction of Pulling Outer Cable

W1035795

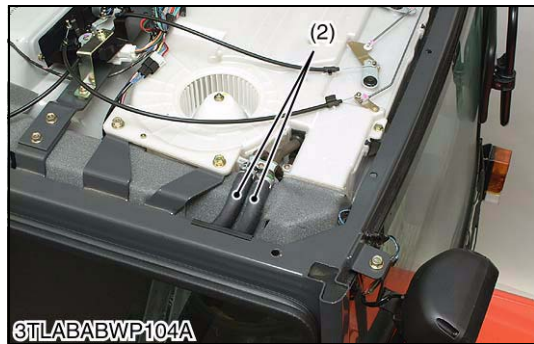
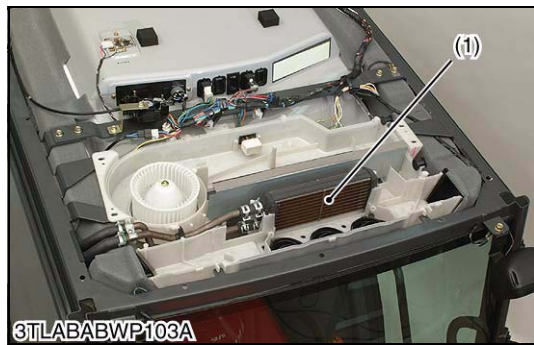

### Air Conditioning Unit

1. Remove the unit cover (1).
2. Disconnect the heater hoses (5).
3. Remove the screws and take off the unit.
4. Remove the duct hoses.

#### (When reassembling)

- When reconnecting the cooler pipes with the unit, apply compressor oil (DENSO.CO. OIL8 or equivalent) to O-rings.
- When remounting the unit, tighten five screws by hand and finally retighten them after aligning the inner roof duct with the unit duct.
- When connecting the heater hose with heater unit, hose should be put into the heater unit pipe more than 30 mm (1.2 in.)

Tightening torque	Heater unit mounting screw (M6)	3.92 to 6.86 N·m 0.40 to 0.70 kgf·m 2.89 to 5.06 ft-lbs
	Heater unit mounting screw (M8)	9.80 to 11.68 N·m 1.00 to 1.19 kgf·m 7.23 to 8.60 ft-lbs

(1) Heater Core

(2) Heater Hoses

W1035995

### (E) Removing Heater Hoses

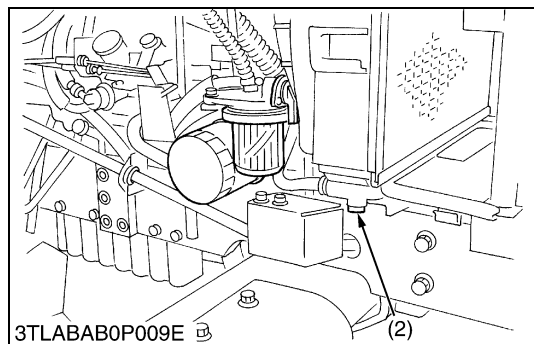
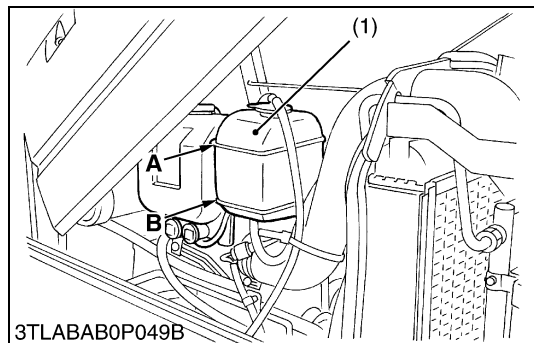

### Draining Coolant

#### ⚠ CAUTION

- **Never remove the radiator cap until coolant temperature is well below its boiling point. Then loosen cap slightly to the stop to relieve any excess pressure before removing cap completely.**

1. Stop the engine and let cool down.
2. Loosen the drain plug (2) to drain the coolant.
3. Remove the radiator cap to completely drain the coolant.
4. After all coolant is drained, retighten the drain plug (2).

#### (When refilling)

- Fill the coolant between the “FULL” and “LOW” marks of recovery tank (1).

Coolant capacity (with recovery tank)	L3830 L4630	8.7 L 9.2 U.S.qts 7.7 Imp.qts
	L5030	9.2 L 9.7 U.S.qts 8.1 Imp.qts

(1) Recovery Tank  
(2) Drain Plug

**A : FULL**  
**B : LOW**

W10652320





### Battery, Front Grill, Skirt and Bonnet

1. Open the bonnet and disconnect the battery negative cable.
2. Disconnect the head light connector and remove the front grill (4).
3. Remove the left and right side skirts (3).
4. Disconnect window washer hoses (2).
5. Remove the bonnet (1).

#### ■ NOTE

- **When disconnecting the battery cords, disconnect the negative cord first, when connecting, positive cord first.**

- |                        |                 |
|------------------------|-----------------|
| (1) Bonnet             | (3) Skirt       |
| (2) Window Washer Hose | (4) Front Grill |

W1065454

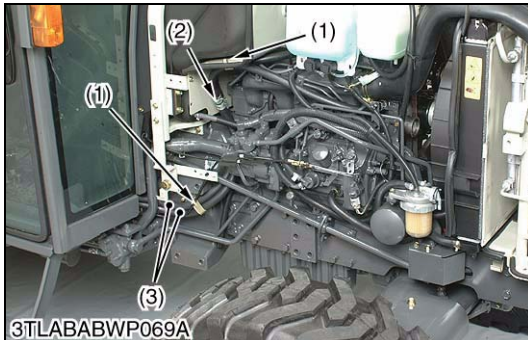

### Hose Clamp

1. Remove the hose bands (1).
2. Remove the hose clamp (2).

#### ■ NOTE

- **Before disconnecting the heater hoses (3), put the parting marks on the hoses for marking proper reconnecting.**
3. Disconnect the heater hoses (3), then take out them under the cabin.

#### (When reassembling)

- Connecting the heater hoses at their original position.

- |                 |                  |
|-----------------|------------------|
| (1) Hose Band   | (3) Heater Hoses |
| (2) Hose Clamps |                  |

W1027385



### Heater Hoses

1. Remove the outer roof.

#### ■ NOTE

- **Before disconnecting the heater hoses (2), put the parting marks on the hoses for marking proper reconnecting.**
2. Disconnect the heater hoses (2) from the hose pipes (1).
  3. Remove the inner covers (3).
  4. Pull out the heater hoses (2) from the bottom of the cabin.
  5. Take out the heater hoses (2).

#### (When reassembling)

- Connect the heater hoses at their original positions.
- In assembling the heater hose (2) to the pipe (1), connect the heater hose with identification mark (white paint) to upper side of the hose pipe.
- When connecting the heater hose with A/C unit, hose should be put into the A/C unit pipe more than 30 mm (1.2 in.).

- |                 |                 |
|-----------------|-----------------|
| (1) Heater Pipe | (3) Inner Cover |
| (2) Heater Hose |                 |

W1027522

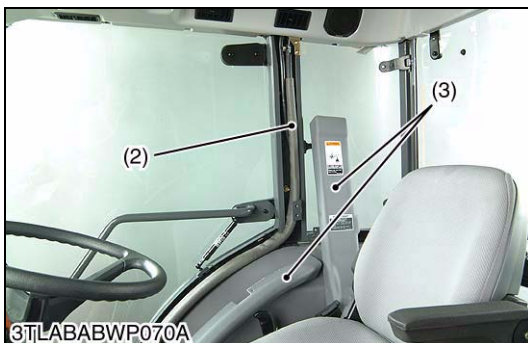

### (3) Servicing

#### (A) Air Conditioner Unit



#### Evaporator

1. Check whether while powder or dust is attached to the evaporator (1). If they are attached, wash them off with warm water and blow them off with compressed air.

#### NOTE

- In case the evaporator is cleaned with warm water, cap the evaporator pipe ends so that water does not enter it.

(1) Evaporator

W1027811

## [4] LIGHTING SYSTEM

### (1) Checking

#### (A) Working Light

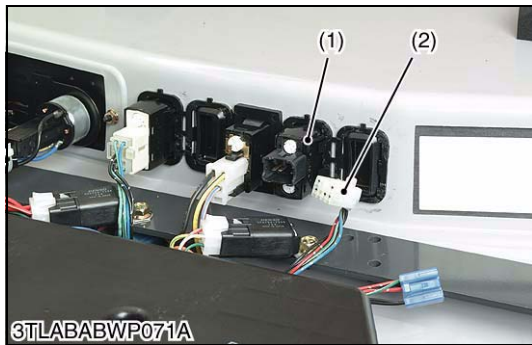

#### Working Light Switch

1. Remove the outer roof, and disconnect the working light switch connector (2) from the working light switch (1).
2. Perform the following checkings **1)** and **2)**.

(1) Working Light Switch

(2) Working Light Switch Connector

W1027926

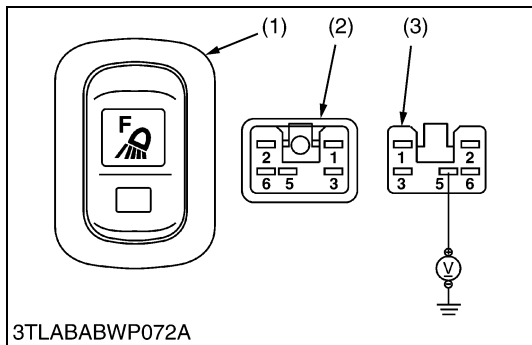

#### 1) Connector Voltage

1. Turn the main switch **ON**.
2. Measure the voltage with a voltmeter between the terminal **5** and chassis.
3. If the voltage differs from the battery voltage, the wiring harness, fuse or main switch is faulty.

Voltage	Terminal 5 – Chassis	Approx. battery voltage
---------	----------------------	-------------------------

#### 2) Working Light Switch

1. Check the continuity through the switch with an ohmmeter.
2. If continuity specified below is not indicated.

Position		Terminal				
		5	6	3	1	2
Working light switch	OFF				● — ●	
	ON	● —	● —	● —		

(1) Working Light Switch

(3) Working Light Switch Connector

(2) Working Light Switch Connector  
(Switch Side)

(Wiring Harness Side)

W1028024

## [5] OTHERS

### (1) Disassembling and Assembling

#### (A) Cabin Windshields

##### Preparation

1. Prepare the followings.
  - Cutter knife 1 piece
  - Scraper 1 piece
  - Gun for coating 1 piece
  - Sika Tack-Ultrafast or equivalent
  - Gummed tape
  - Sika-Activator
  - Sika primer 209
  - Shin Etsu silicon KE45

##### ■ NOTE

- Sika product are made by Sika Corporation.
- Shin Etsu silicon KE45 is made by Shin Etsu Polymer Corporation.
- These materials can't be provided by Kubota Corporation.
- Therefore, please find the local made equivalent materials in your country and use them when you need.

W1053361

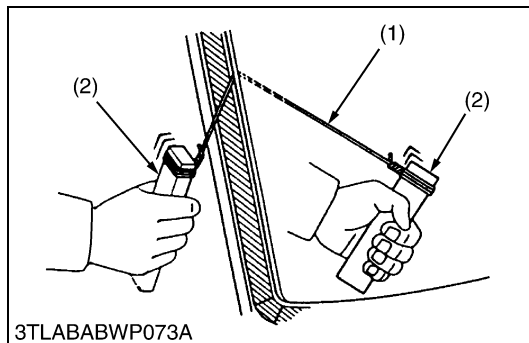

3TLABABWP073A

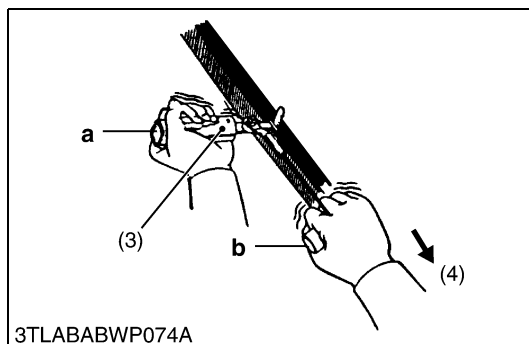

3TLABABWP074A

##### Before Replacing Windshields (1)

###### [In case of using piano wire (When glass is cracked)]

1. Thread the piano wire from the inside of cabin. Tie its both ends to a wooden blocks or the like. (See the left figure.)
2. Pull the piano wire inward/outward alternately to cut the adhered part.

##### ■ NOTE

- Do not let the piano wire make sliding contact with the edge of glass plate forcibly.

###### [In case of using cutter knife (When glass is totally crushed finely)]

1. Insert the knife (3) into the adhered part.
2. Keep the edge of knife blade square to the glass edge at the part (a). Slide the knife blade along the glass surface and the edge. Pull the part (b) in the direction parallel to the glass edge to cut them off.

##### ■ NOTE

- Find a wider gap between the glass and body.
- Take care of handling the cutter knife not to damage your hand.

- |                |                  |
|----------------|------------------|
| (1) Piano Wire | (3) Cutter Knife |
| (2) Wood Peace | (4) Pulling      |

W1035600

##### Before Replacing Windshields (2)

1. When the Sika Tack-Ultrafast or equivalent attached to the cabin frame and the glass are reused, remove the bond clearly.
2. Clean the frame surface with Sika-Activator.

##### ■ NOTE

- Remove the bond completely.

W1035852

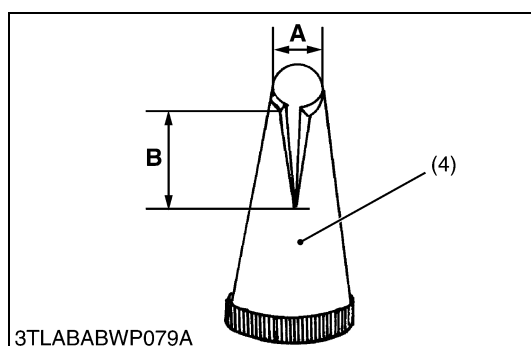
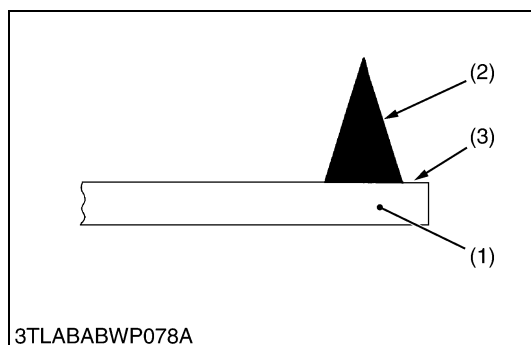
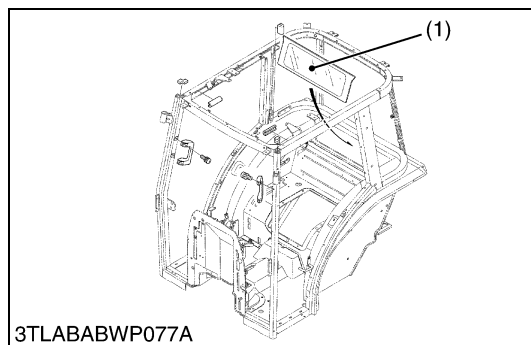
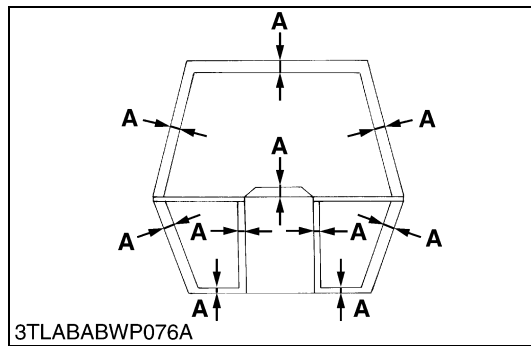
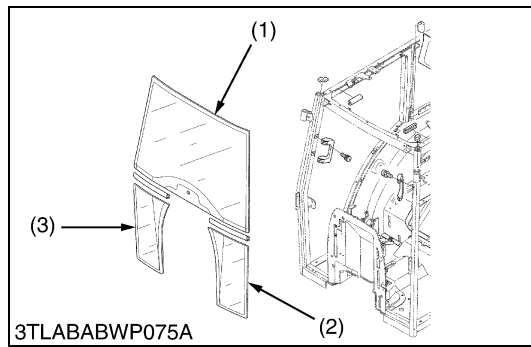

### Before Replacing Windshields (3)

1. Check that the glasses are not damaged and cracked.
2. Turn over the glass and clean this surface of the glass by Sika-Activator.
3. The cleaning area of the rear surface is indicated "A" in the figure left.

#### NOTE

- **If not cleaning the glass, it may result in adhesive failure.**

- (1) Upper Windshield  
 (2) Lower Windshield (Left)  
 (3) Lower Windshield (Right)

A : 18 to 22 mm (0.71 to 0.87 in.)

W1035931

### Rear Windshield

1. Apply a Sika primer 209 on the cabin frame.
2. Apply a Sika-Activator (3) on the rear windshield shown in figure.
3. Apply a Sika Tack-Ultrafast (2) (or equivalent) on the rear windshield (1) as shown in figure.
4. Install the rear windshield (1) to the cabin and fix it with a gummed tape.
5. Leave it for one hour.

#### NOTE

- **Apply the Sika Tack-Ultrafast (or equivalent) with the jig having the specified tip shape as shown in the figure left.**
- **Apply it with a uniform speed to minimize unevenness.**
- **Follow the instruction manual of Sika Tack-Ultrafast.**
- **When the gummed tape is removed the rear windshield may be displaced. In this case fix it again.**
- **Remove the gummed tape (adhesive tape) little by little to confirm the bonding condition.**

- (1) Rear Windshield                      A : 8 mm dia. (0.31 in. dia.)  
 (2) Sika Tack-Ultrafast                B : 12 mm (0.47 in.)  
 (3) Sika-Activator  
 (4) Jig

W1054050

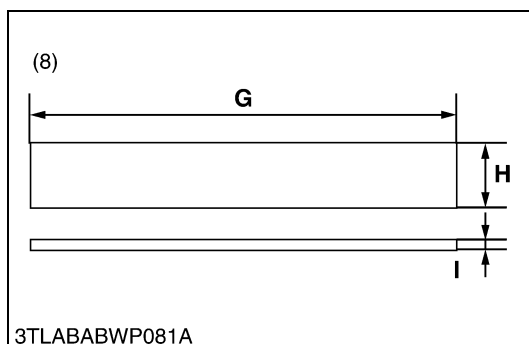
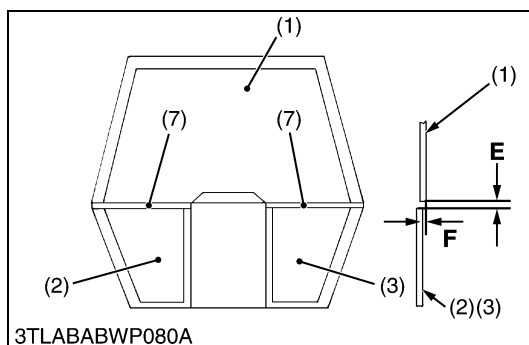
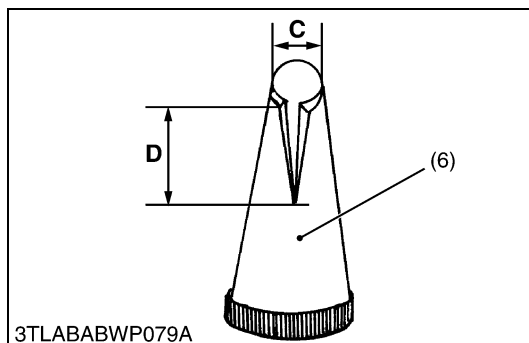
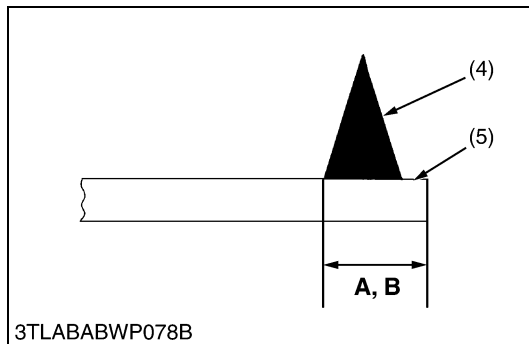
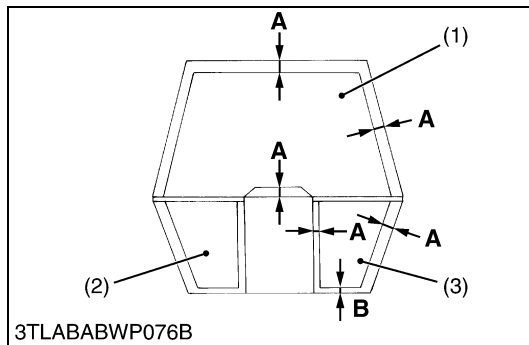

### Front Windshield

#### NOTE

- Apply the Sika Tack-Ultrafast (or equivalent) with the jig having the specified tip shape as shown in the figure left.
- Apply it with a uniform speed to minimize unevenness.
- Follow the instruction manual of Sika Tack-Ultrafast.

1. Apply the Sika Primer 209 on the cabin frame **A** and **B** in the figure.
2. Apply the Sika-Activator (5) on the windshield **A** and **B** in the figure.
3. Apply the Sika Tack-Ultrafast (4) on the windshield **A** and **B** in the figure.
4. Install the lower (left or right) windshield to the cabin and fix it with a gummed tape.
5. Set the upper windshield to the cabin and fix it with a gummed tape.

#### NOTE

- Use a jig (8) shown in the figure to create even clearance **E** [approx. 5 mm (0.2 in.)] between the lower and upper windshield.
- The level unevenness between the upper and lower windshields should be -1 to +1 mm (-0.04 to +0.04 in.) or less at the windshield surface.

6. Leave it for one hour.
7. Remove the jig (8).
8. Install the H rubber (7) between the lower and upper windshield (2), (3).
9. Apply the Shin Etsu silicon KE45 in H rubber (7).
10. Apply the Shin Etsu silicon KE45 on the edge of H rubber (7).

#### NOTE

- When the gummed tape is removed, the glass may be displaced. In this case fix it again.
- Remove the gummed tape (adhesive tape) little by little to confirm the bonding condition.

- |                              |  |
|------------------------------|--|
| (1) Upper Windshield         | A : 10 mm (0.39 in.)                     |
| (2) Lower Windshield (Right) | B : 12 mm (0.47 in.)                     |
| (3) Lower Windshield (Left)  | C : 8 mm dia. (0.31 in. dia.)            |
| (4) Sika Tack-Ultrafast      | D : 12 mm (0.47 in.)                     |
| (5) Sika Activator           | E : 5 mm (0.2 in.)                       |
| (6) Jig                      | F : -1.0 to +1.0 mm (-0.04 to +0.04 in.) |
| (7) H Rubber                 | G : 300 mm (11.8 in.)                    |
| (8) Jig                      | H : 20 mm (0.8 in.)                      |
|                              | I : 5 mm (0.2 in.)                       |

W1054287

---

**EDITOR:**

KUBOTA FARM & INDUSTRIAL MACHINERY SERVICE, LTD.

64, ISHIZU-KITAMACHI, SAKAI-KU, SAKAI-CITY, OSAKA, 590-0823, JAPAN

PHONE : (81)72-241-1129

FAX : (81)72-245-2484

E-mail : ksos-pub@kubota.co.jp

---