

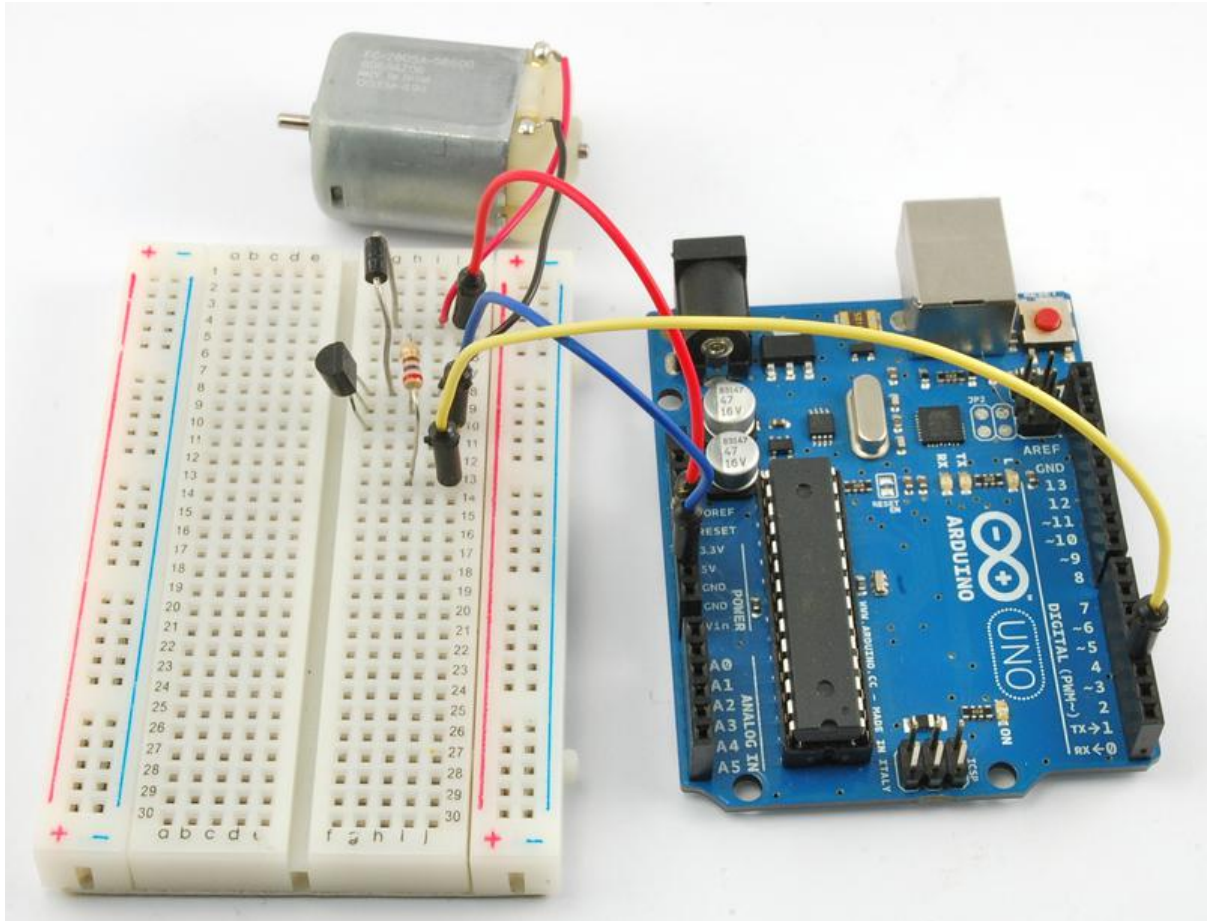

# Arduino Lesson 13. DC Motors

Created by Simon Monk



<https://learn.adafruit.com/adafruit-arduino-lesson-13-dc-motors>

Last updated on 2021-11-15 05:52:36 PM EST

# Table of Contents

Overview	3
Parts	3
• Part	
• Qty	
Breadboard Layout	7
Arduino Code	8
Transistors	9
Other Things to Do	11

---

# Overview

In this lesson, you will learn how to control a small DC motor using an Arduino and a transistor.

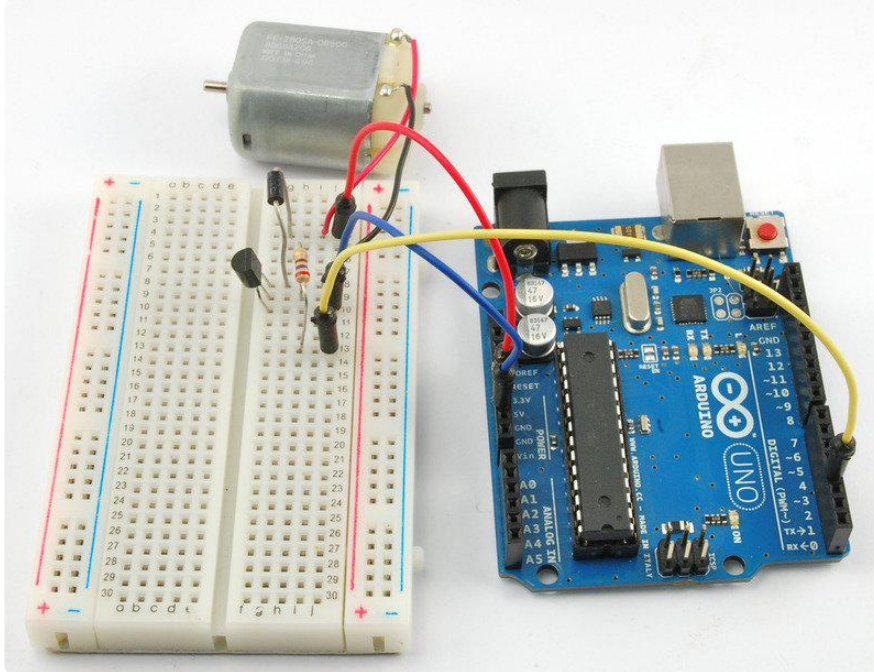

You will use an Arduino analog output (PWM) to control the speed of the motor by sending a number between 0 and 255 from the Serial Monitor.

---

# Parts

To build the project described in this lesson, you will need the following parts.

Part  
Qty

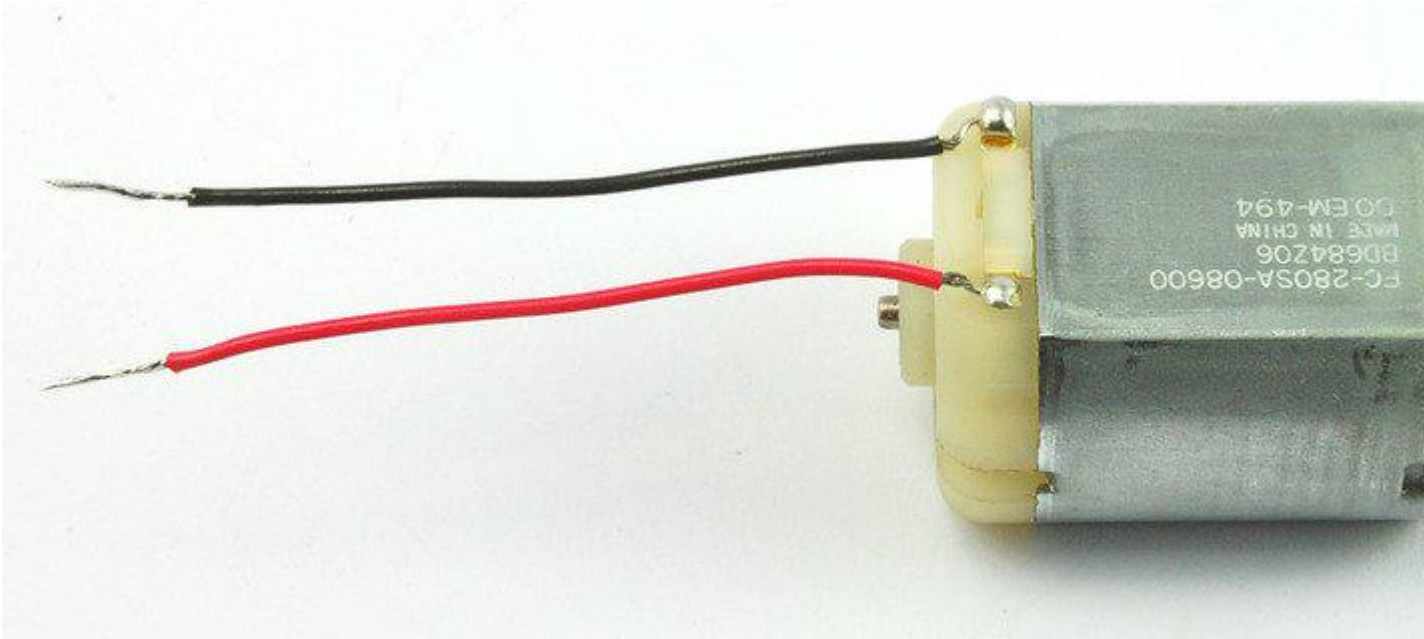

Small 6V DC Motor

1

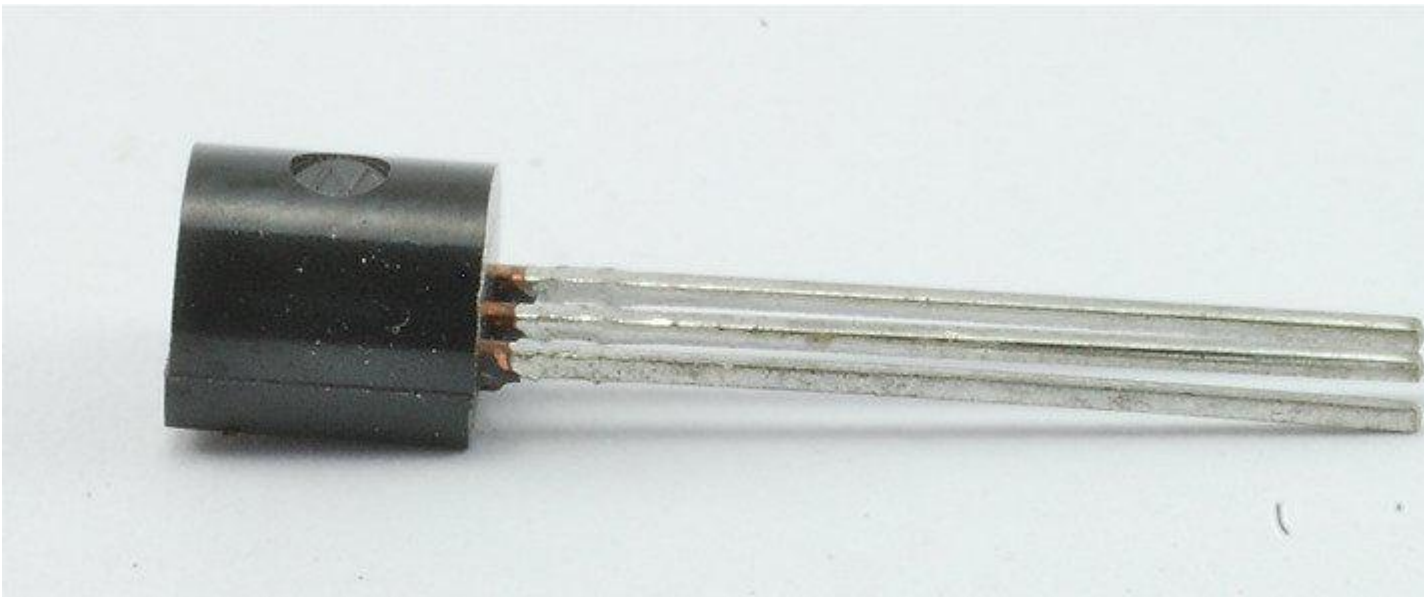

PN2222 Transistor

1





1N4001 diode

1



270  $\Omega$  Resistor (red, purple, brown stripes)

1

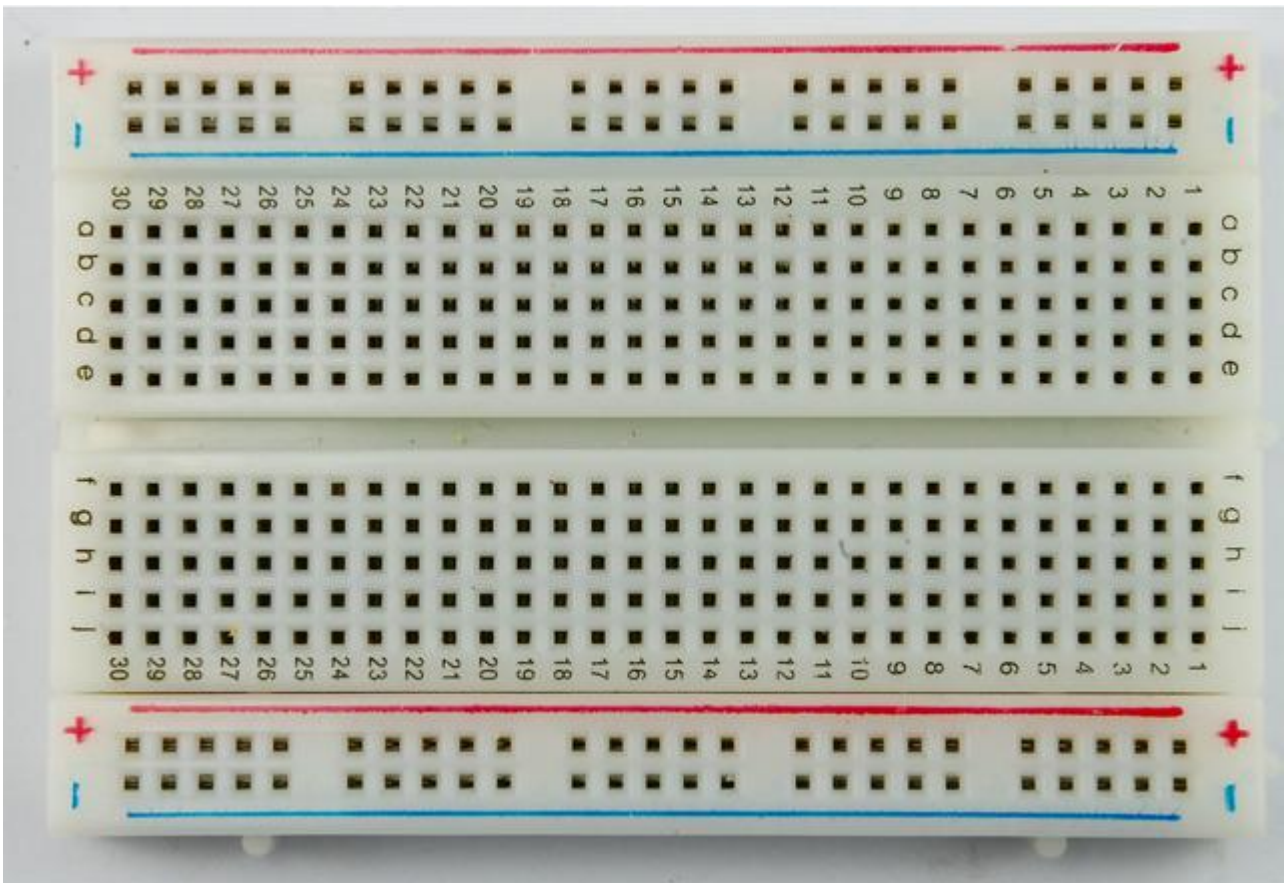

Half-size Breadboard

1

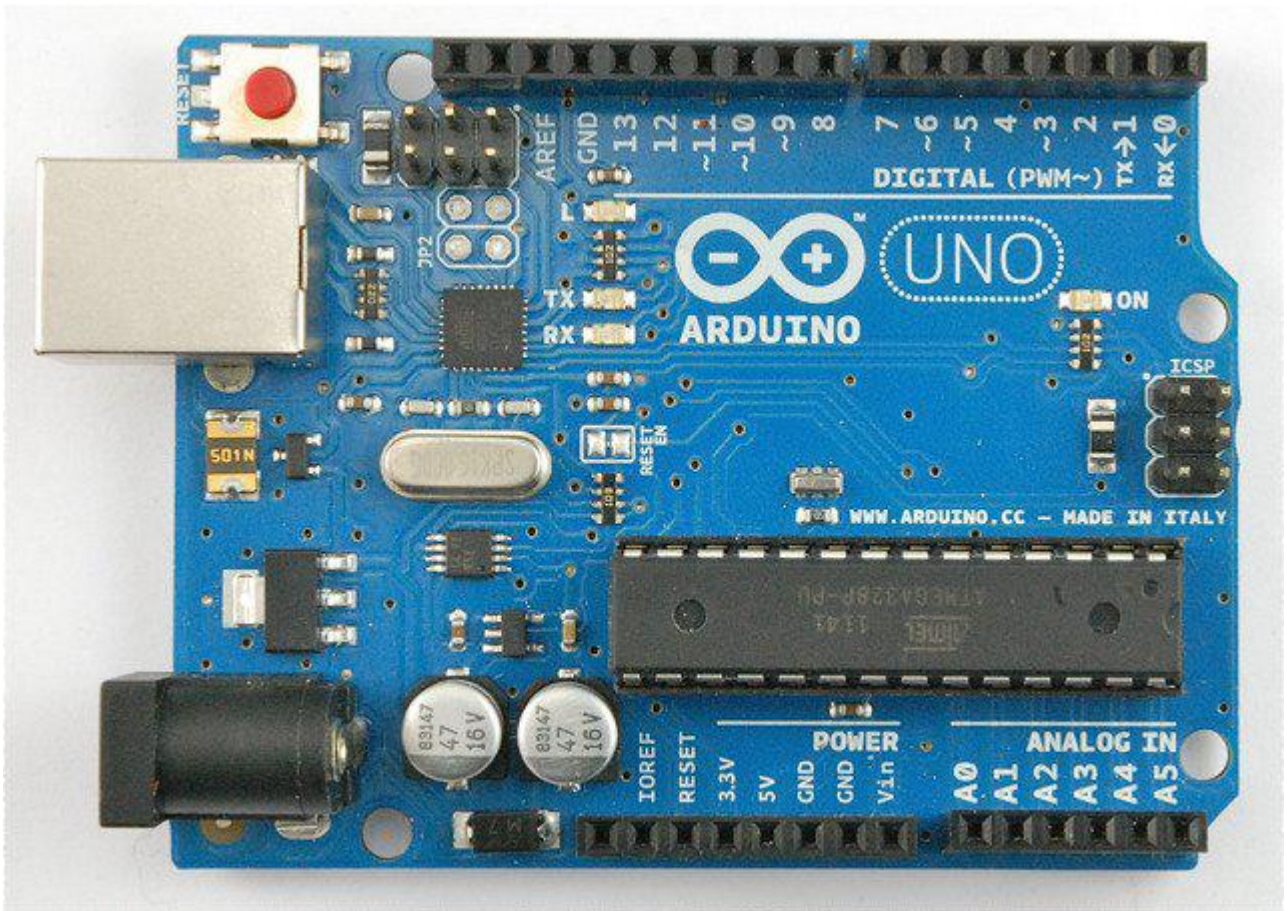

Arduino Uno R3

1

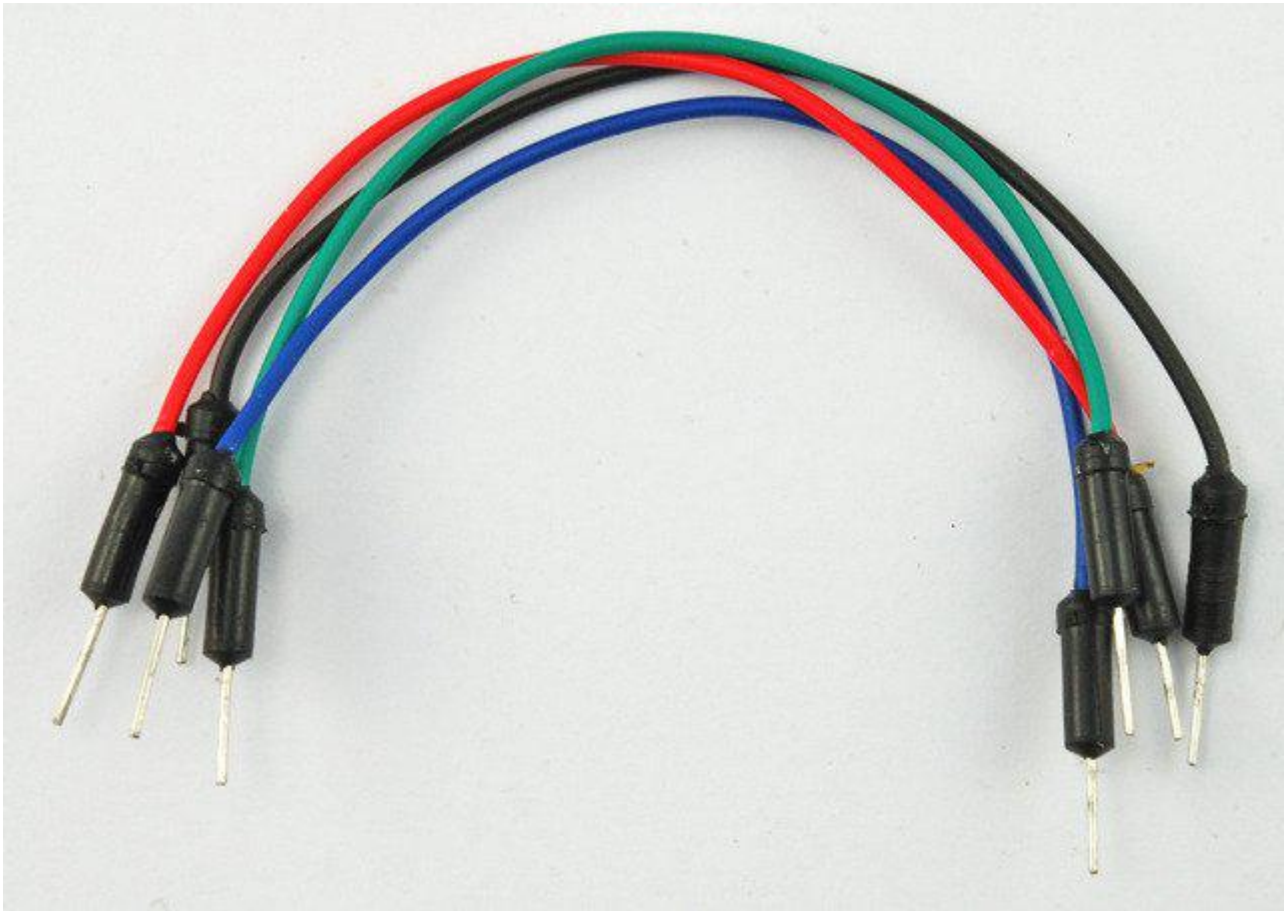

Jumper wire pack

1

---

## Breadboard Layout

When you put together the breadboard, there are two things to look out for.

Firstly, make sure that the transistor is the right way around. The flat side of the transistor should be on the right-hand side of the breadboard.

Secondly the striped end of the diode should be towards the +5V power line - see the image below!

The motor that comes with Adafruit Arduino kits does not draw more than 250mA but if you have a different motor, it could easily draw 1000mA, more than a USB port can handle! If you aren't sure of a motor's current draw, power the Arduino from a wall adapter, not just USB



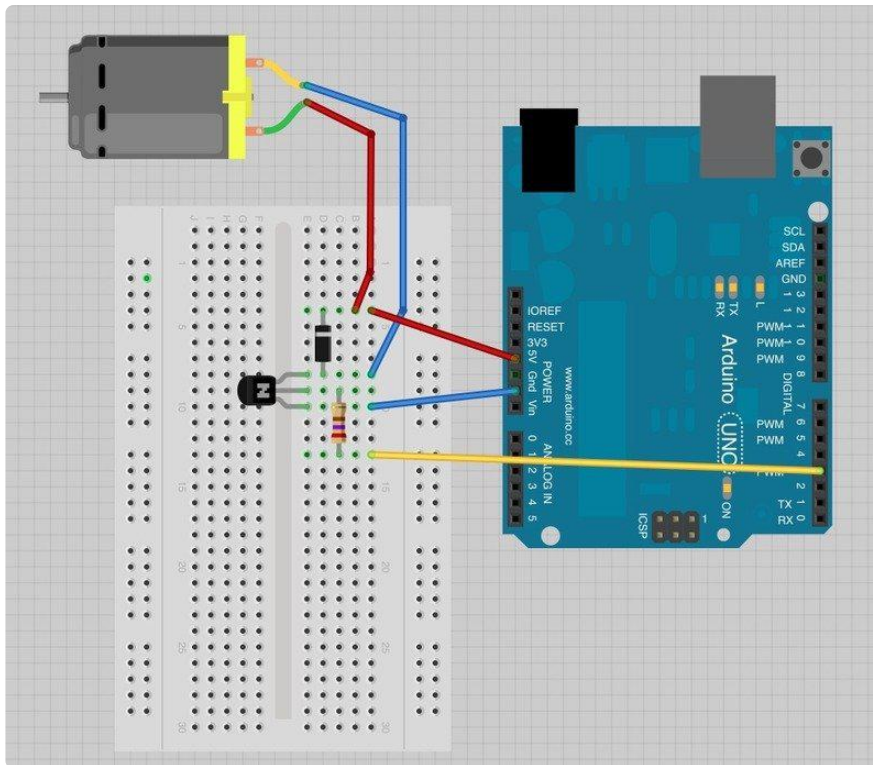

The motor can be connected either way around.

## Arduino Code

Load up the following sketch onto your Arduino.

```
/*
Adafruit Arduino - Lesson 13. DC Motor
*/

int motorPin = 3;

void setup()
{
  pinMode(motorPin, OUTPUT);
  Serial.begin(9600);
  while (! Serial);
  Serial.println("Speed 0 to 255");
}

void loop()
{
  if (Serial.available())
  {
    int speed = Serial.parseInt();
    if (speed >= 0 && speed <= 255)
    {
      analogWrite(motorPin, speed);
    }
  }
}
```



The transistor acts like a switch, controlling the power to the motor, Arduino pin 3 is used to turn the transistor on and off and is given the name 'motorPin' in the sketch.

When the sketch starts, it prompts you, to remind you that to control the speed of the motor you need to enter a value between 0 and 255 in the Serial Monitor.

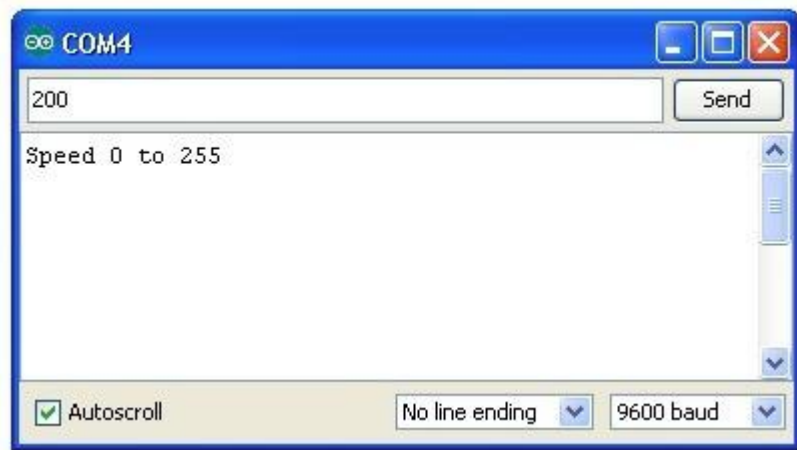

In the 'loop' function, the command 'Serial.parseInt' is used to read the number entered as text in the Serial Monitor and convert it into an 'int'.

You could type any number here, so the 'if' statement on the next line only does an analog write with this number if the number is between 0 and 255.

---

## Transistors

The small DC motor, is likely to use more power than an Arduino digital output can handle directly. If we tried to connect the motor straight to an Arduino pin, there is a good chance that it could damage the Arduino.

A small transistor like the PN2222 can be used as a switch that uses just a little current from the Arduino digital output to control the much bigger current of the motor.

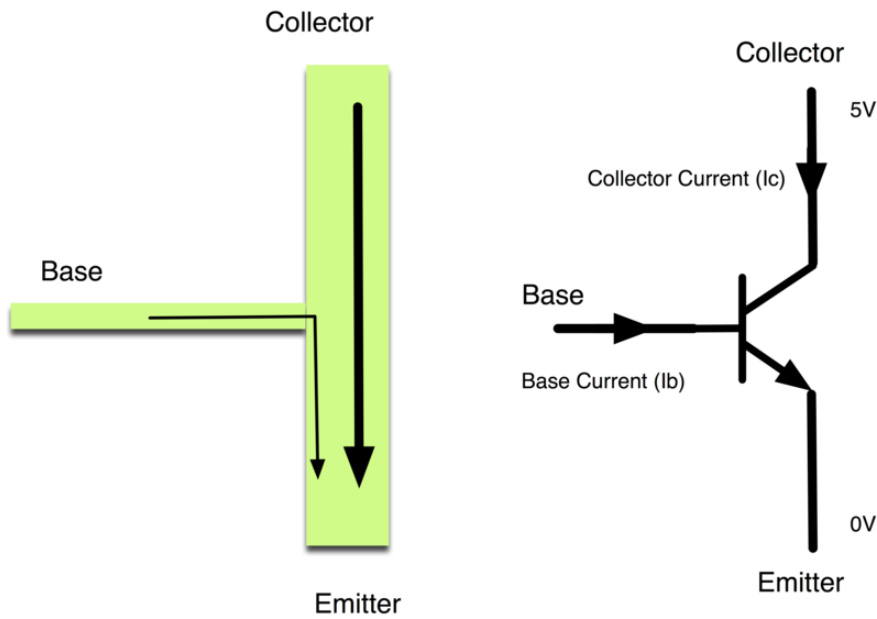

The transistor has three leads. Most of the electricity flows from the Collector to the Emitter, but this will only happen if a small amount is flowing into the Base connection. This small current is supplied by the Arduino digital output.

The diagram below is called a schematic diagram. Like a breadboard layout, it is a way of showing how the parts of an electronic project are connected together.

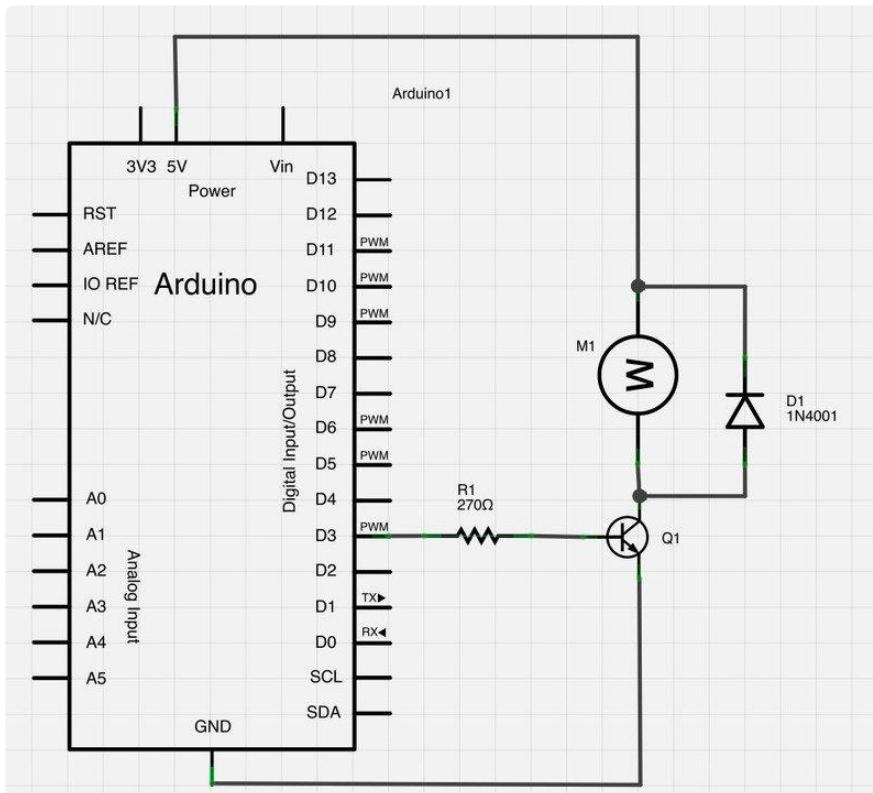

The pin D3 of the Arduino is connected to the resistor. Just like when using an LED, this limits the current flowing into the transistor through the base.

There is a diode connected across the connections of the motor. Diodes only allow electricity to flow in one direction (the direction of their arrow).

When you turn the power off to a motor, you get a negative spike of voltage, that can damage your Arduino or the transistor. The diode protects against this, by shorting out any such reverse current from the motor.

---

## Other Things to Do

Try reversing the connections to the motor. What happens?

Try entering different values (starting at 0) into the Serial Monitor and notice at what value the motor starts to actually turn. You will find that the motor starts to 'sing' as you increase the analog output.

Try pinching the drive shaft between your fingers. Don't hold it like that for too long, or you may cook the transistor, but you should find that it is fairly easy to stop the motor. It is spinning fast, but it does not have much torque.

Click Here for the Next Lesson

<https://adafru.it/aUE>

### About the Author

Simon Monk is author of a number of books relating to Open Source Hardware. The following books written by Simon are available from Adafruit: [Programming Arduino \(http://adafru.it/1019\)](http://adafru.it/1019), [30 Arduino Projects for the Evil Genius \(http://adafru.it/868\)](http://adafru.it/868) and [Programming the Raspberry Pi \(https://adafru.it/aM5\)](https://adafru.it/aM5).