

10 Schematic Diagrams

10-1 Signal Input Part Schematic Diagram

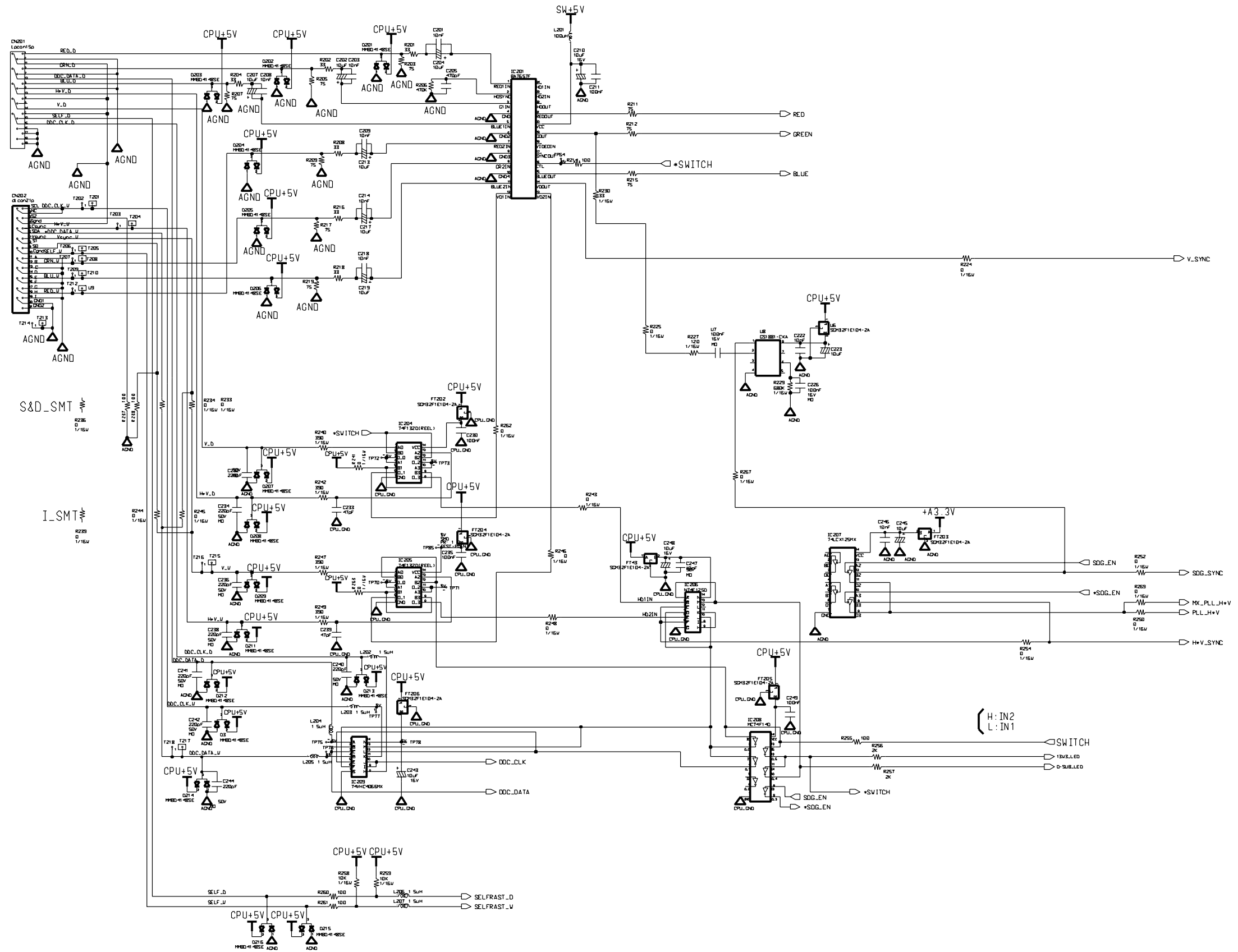

10-2 Scaler Chip Part Schematic Diagram

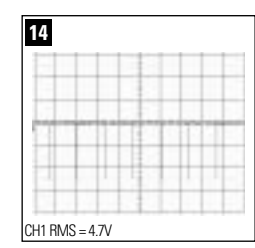
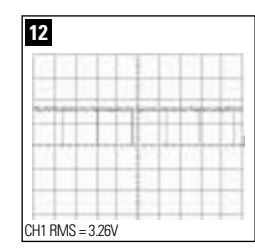
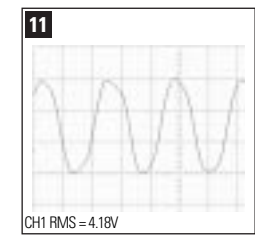
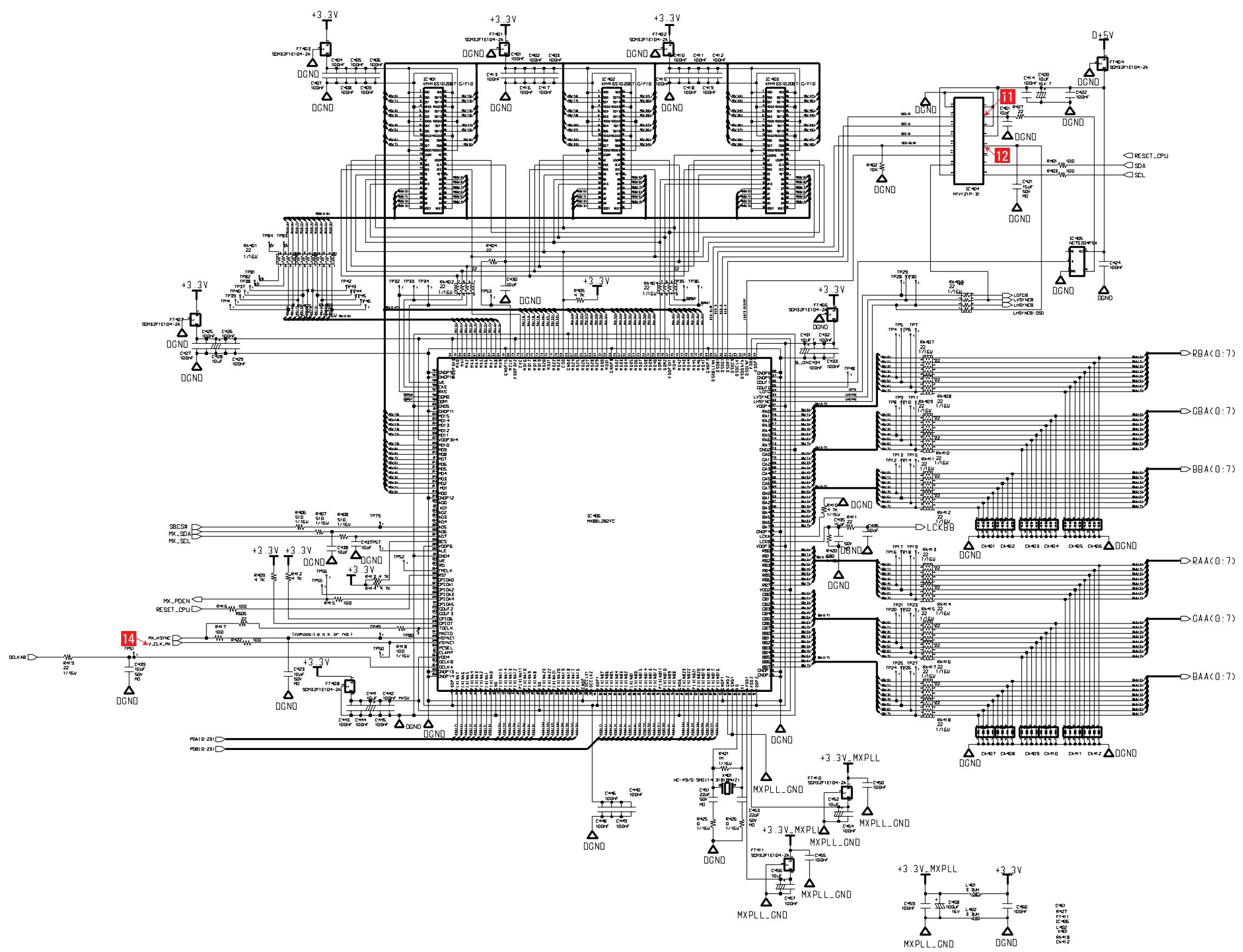

10-3 Power input part & TMD5(LCD panel interface) part Schematic Diagram

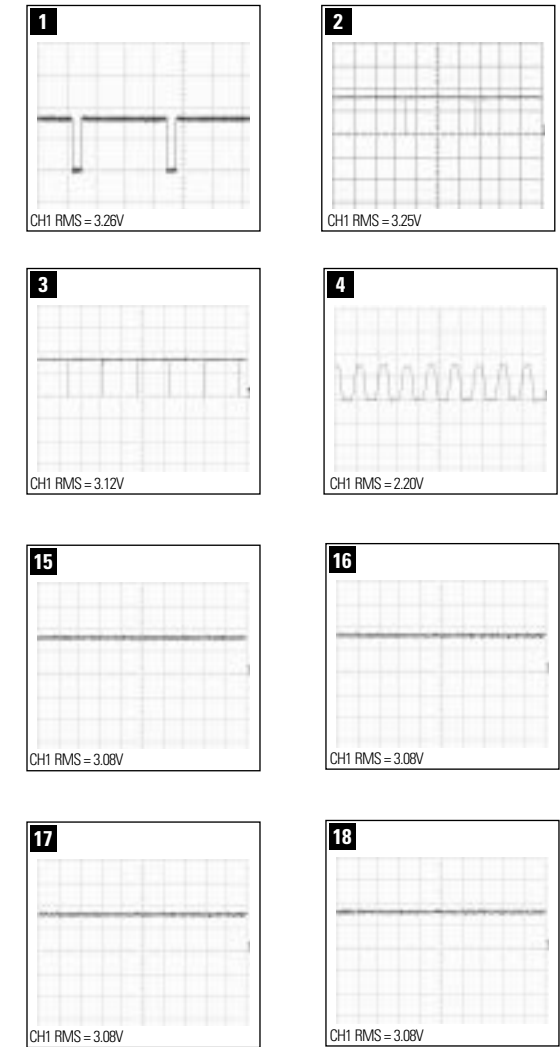
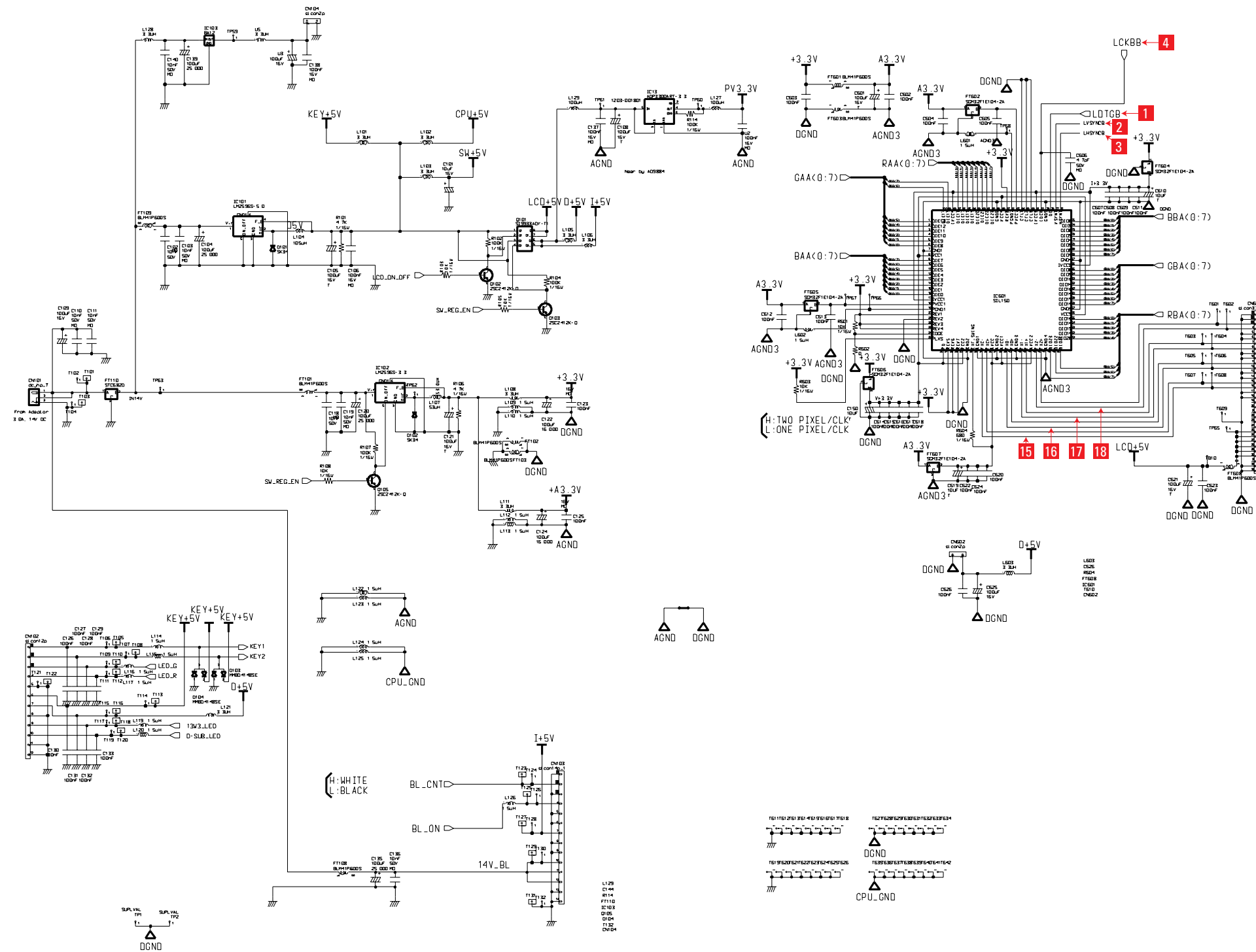

10-4 Micom Part Schematic Diagram

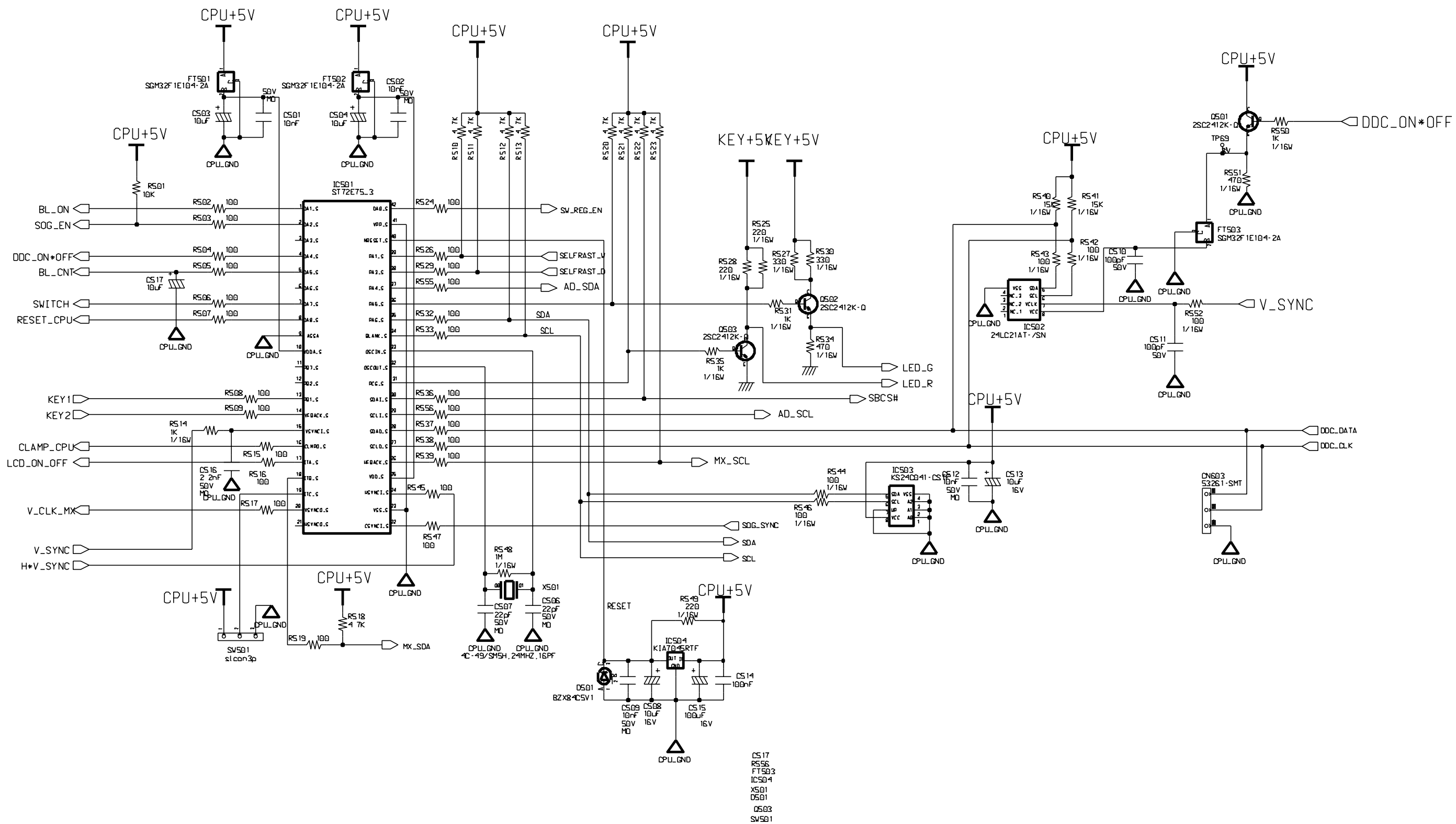

10-5 A/D Converter Part Schematic Diagram

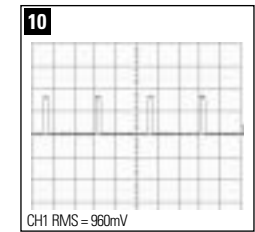
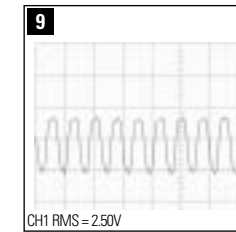
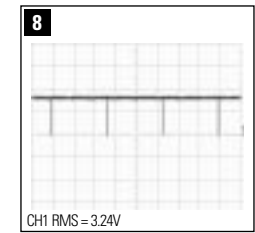
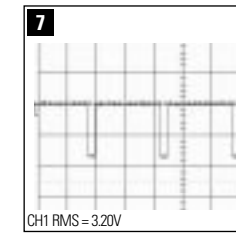
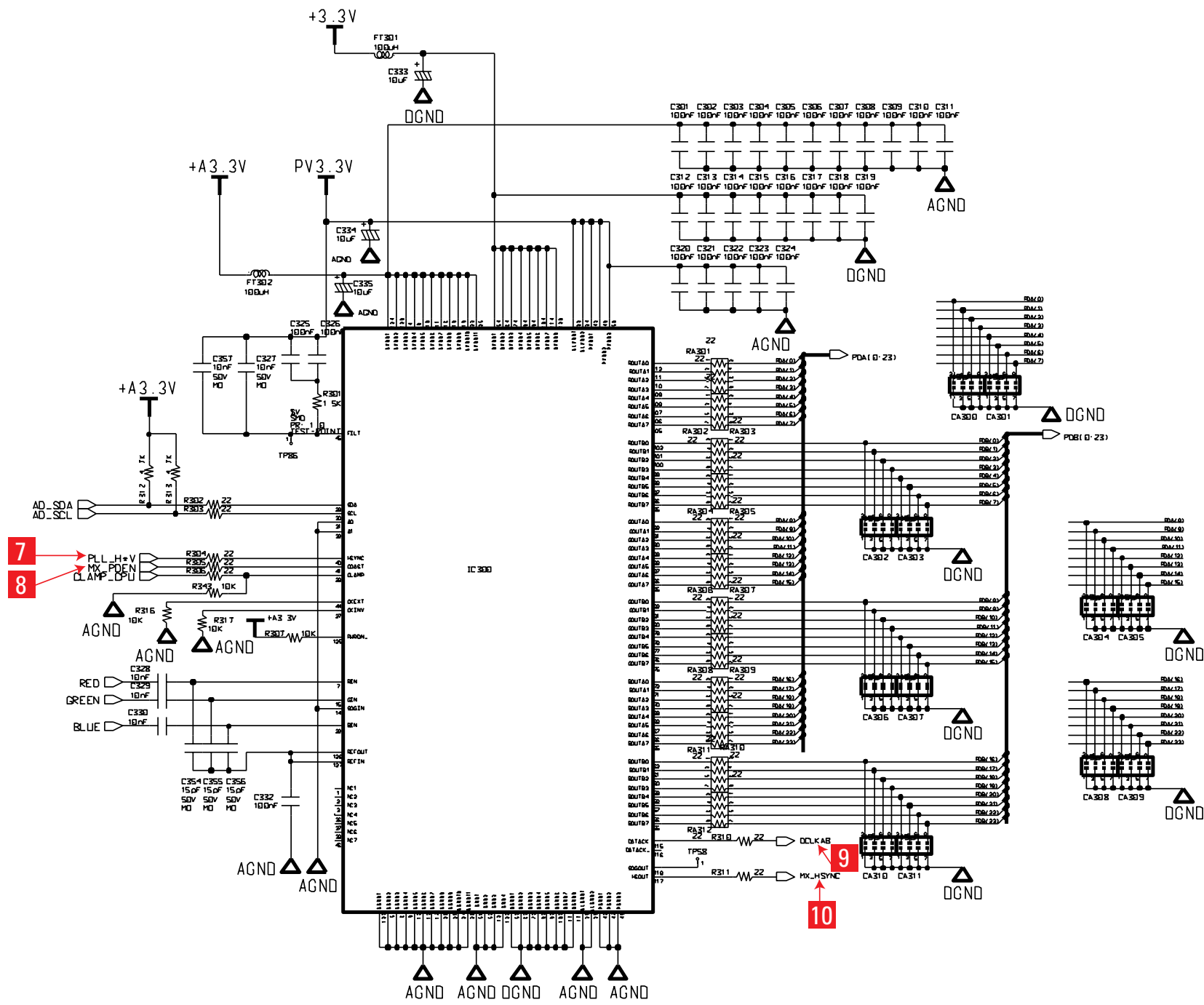

- C356
- R343
- L302
- RA312
- FT3016
- IC303
- CA311