

# "In the Beekeeper's Work Shop" Building a Bee Hive: The Inner Hive Cover

©by Stephen E. Tilmann

## The Inner Hive Cover

The project for this article is an inner hive cover. The inner cover sits on top of the topmost hive body (super) and underneath the telescoping top cover (Figure 1). The purpose of an inner cover is to provide the correct bee space on the top hive body and provide good air ventilation within the hive.

With a bee escape device in the ventilation hole, an inner cover can also be used to clear bees from a super prior to harvesting honey. When used in this manner, the inner cover is called an "escape board". The board is placed beneath the hive body to be cleared of bees. A pair of light springs on the bee escape acts as a "one way" door, through which bees can pass in only one direction. The escape board can be a non-chemical means of clearing bees from a super.

There is a top and a bottom side of an inner hive cover. When completed, the side with the insert flush to the frame is the bottom; the side with the 1/2-inch (or so) raised rim of the frame is the top. In the photo, you are looking at the bottom of the inner hive cover.

You will always want to have a few extra inner covers around, so you may want to consider making a few more than the number of hives you are running.



### Basic Construction

The inner cover is a frame with a plywood or tempered Masonite® insert. The assembled dimensions of the inner cover for a standard 10-frame hive is 16-1/4" wide by 19-7/8" long and made out of 3/4" wood stock (Figure 2). The inside of the frame features a rabbet forming a 3/4-inch ledge with supports the insert. The depth of the rabbet is the same as the thickness of the insert; thus the insert is flush with the frame. Because the insert is glued to the ledge, a simple rebate joint is sufficiently strong for this project.

The insert has a hole for ventilation. Commercial inner covers have rounded ends on the vent and these plans describe two methods of creating this nice feature. If you are using a bee escape, the dimensions of the hole are important.

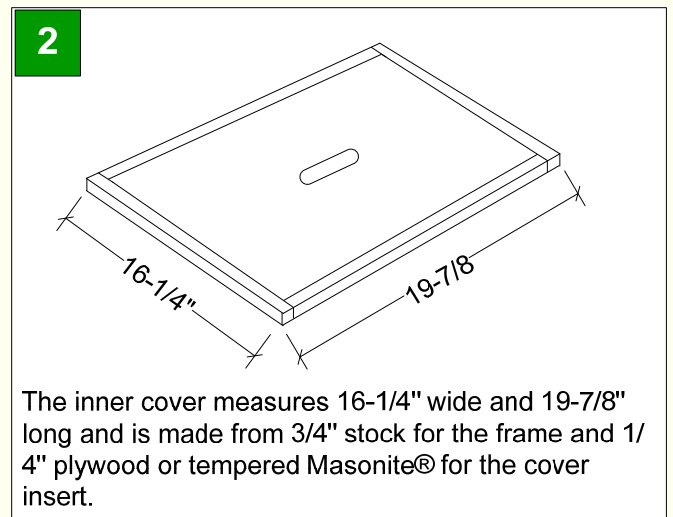
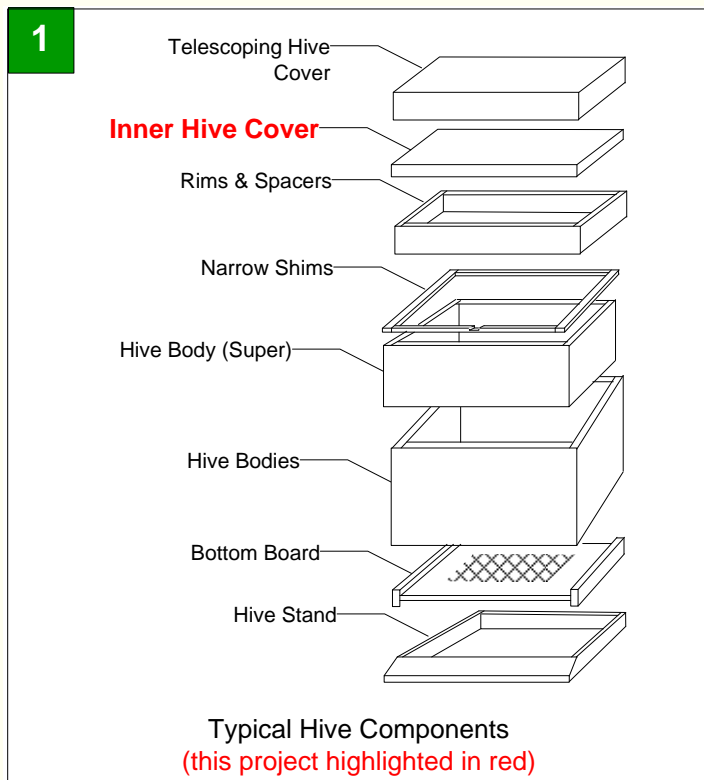

# "In the Beekeeper's Work Shop"

## Building a Bee Hive: The Inner Hive Cover

©by Stephen E. Tilmann

### Before You Begin...

All of the dimensions shown in the drawings and cut list are for a standard 10-frame hive. A table is provided at the back of this article with the sizes of the various components for an 8-frame hive and a 5-frame nuc.

### Construction Details (For a Standard 10-Frame Hive)

#### Step 1. Cut the Frame Sides and Ends

From 1x4 pine, rip two side pieces 18-3/8" long and 1-1/2" wide and two end pieces 16-1/4" long and 1-1/2" wide (Figure 3).

#### Step 2. Cut a Rabbet for the Cover

For each of the pieces cut in step 1, create a ledge for the 1/4" plywood cover piece (Figure 4). The ledge should be 3/4" wide and the depth equal to the thickness of the plywood cover. Note that not all "1/4" plywood measure a full 1/4 inch thick. You want the top of the insert to be even with the top of the frame.

#### Step 3. Join the Frame with a Rebate Joint

From each end of the two frame ends (the 16-1/4" pieces), remove 1-1/2" from the ledge cut in the previous step (Figure 5). This will allow the long sides of the frame to butt up against the ends and conceal the end grain of the sides.

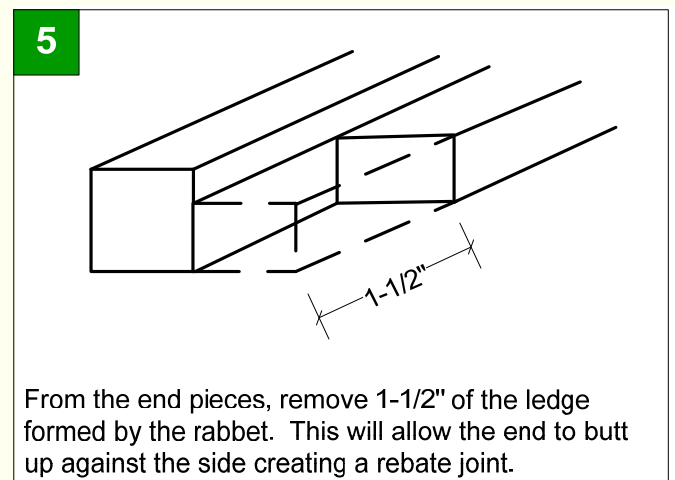
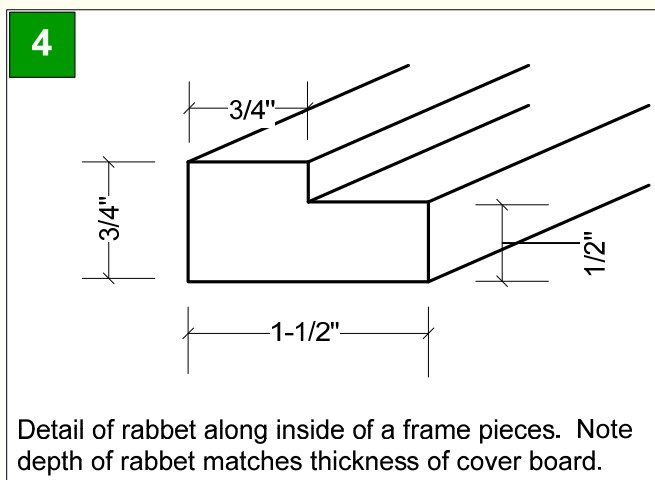
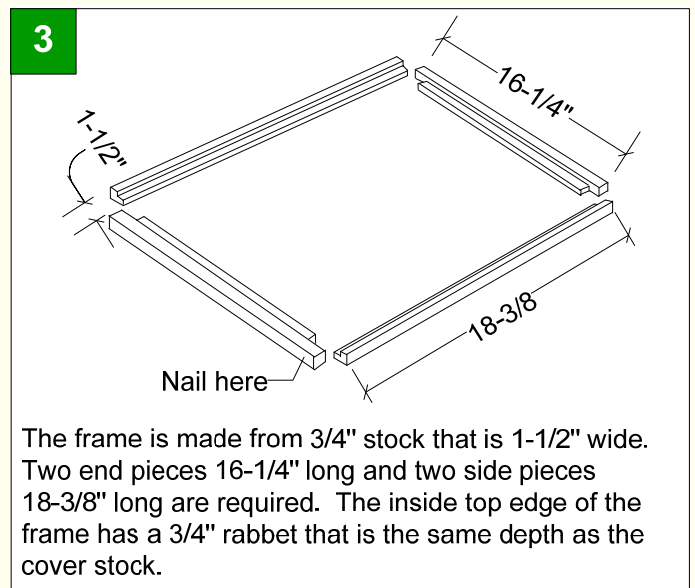

# *"In the Beekeeper's Work Shop"*

## *Building a Bee Hive: The Inner Hive Cover*

©by Stephen E. Tilmann

### **Step 4. Assemble the Frame**

The frame can now be assembled (Figure 6). Dry fit to make sure everything fits together and is square. Glue the frame together and use a couple of 1-1/2" 18 ga. nails on each corner. Note: you may want to pre-drill holes if using larger diameter nails to prevent splitting.

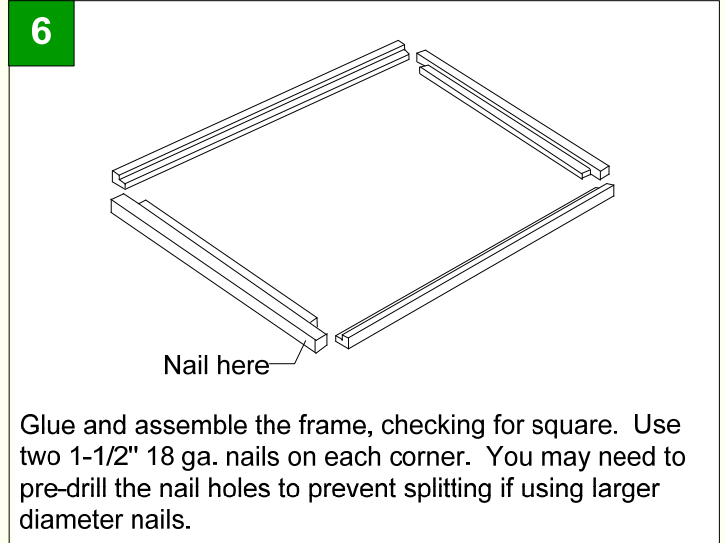

### **Step 5. Make the Cover Piece**

From a 1/4" sheet of plywood, cut a piece 14-3/4" by 18-3/8" (Figure 7). This piece should just fit on the ledge of the assembled frame. You can also use hardboard (tempered Masonite®) for the cover piece.

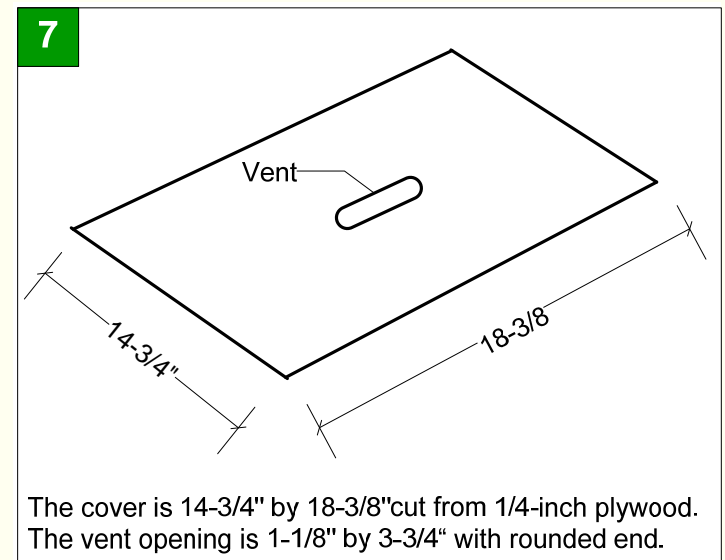

### **Step 6. Cut Out the Vent Opening**

The vent is centered in the cover and is 1-1/8" wide and 3-3/4" long with rounded ends (Figure 8). After marking out the location, you can use a 1-1/8" spade bit to make the rounded ends. (To prevent breakout, drill the hole partway through the plywood and then flip over to complete.) The straight sides can be cut with a jig saw. Sand the edges of the opening smooth.

As an alternative, you can use a router with a flush trim bit to make a more professional looking cutout. Since you will probably be making more than one inner cover during the course of your beekeeping career, we suggest you make a template out of 1/4" hardboard (tempered Masonite®).

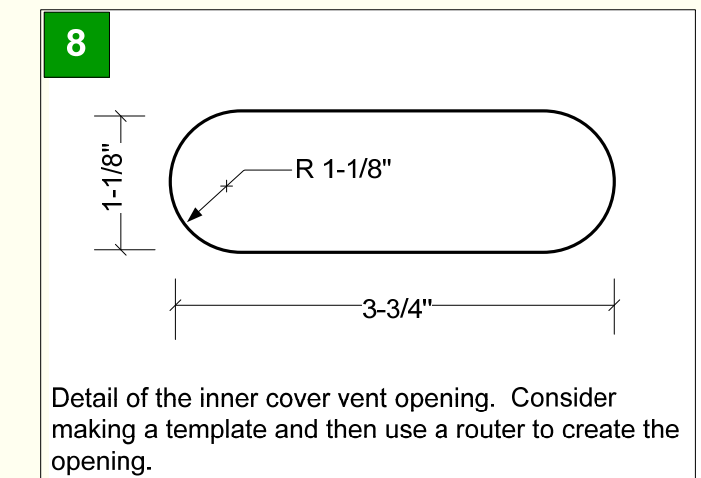

# *“In the Beekeeper’s Work Shop”*

## *Building a Bee Hive: The Inner Hive Cover*

©by Stephen E. Tilmann

### **Step 6. Cut Out the Vent Opening (cont’d)**

If you already have a commercially made inner cover, the simplest way to make your template is to cut a piece of hardboard to the size of this inner cover. Clamp the hardboard on the inner cover, drill a starter hole in the opening and then use a flush trim bit on a router to remove the template material in the opening.

If starting from scratch, mark out the ventilation opening on the template. Drill out the ends and cut the sides as previously described. Sand smooth.

To create the opening in the inner cover you are making, simply follow these same steps, only this time use the template as your guide. Place the template over the plywood cover, drill a pilot hole and then remove the material in the opening with a router.

You have a couple of options with the router. One is to simply clamp the template over the plywood, drill a starter hole with a spade bit and remove the material in the template’s opening from above (see photo top right). Small bar clamps can be used to hold the pieces above the work bench for clearance.

Another option is to use a router table. Secure the template to the plywood with a couple strips of carpet tape (photo at right, second from bottom). Then remove the material in the template’s opening with a flush trim bit (photo at bottom).

Clean up the edges with a bit of sand paper.



# *“In the Beekeeper’s Workshop”*

## *Building a Bee Hive: The Inner Hive Cover*

©by Stephen E. Tilmann

### **Step 7. Install the Cover**

To install the cover piece, run a bead of glue around the frame’s ledge (Figure 9). Place the cover on the ledge and staple with sufficient 1/2” staples to hold the cover while the glue sets. The cover will be flush with the frame.

### **Step 8. Paint the Completed Inner Cover**

We suggest that you paint both sides of the inner cover. Use a quality latex primer and two top coats. Don’t skimp on the paint job since it will probably be the last time you paint the inner cover. A good paint job will greatly prolong the life of your equipment.

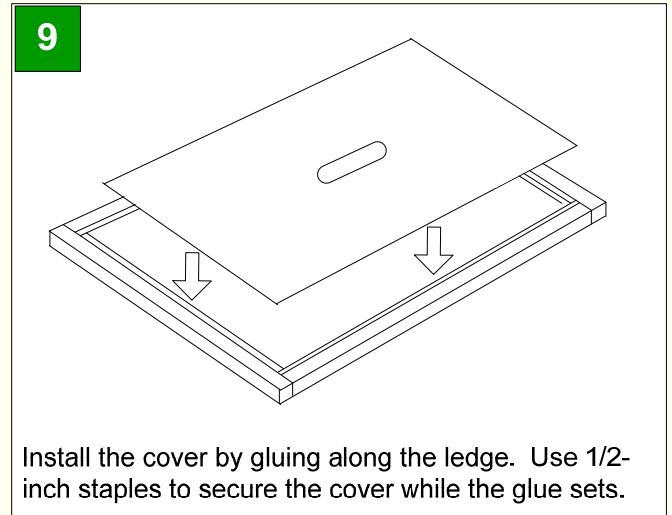

Revision Log:  
3/25/12: Correct length of cover insert, List of Materials

### **Apiary Tip**

Some beekeepers like to create an additional opening along the front side of the inner cover. This is usually a dado 3/8" deep and about 1-inch long. The bees will use this opening for coming and going and it provides additional ventilation

### **Resources**

Dadant & Sons (1997). *The Hive and the Honey Bee*. Chapter 12.

“Building a Bee Hive” series. Published on-line at [www.michiganbees.org/beekeeping/in-the-beekeeper’s-workshop](http://www.michiganbees.org/beekeeping/in-the-beekeeper’s-workshop). For other beekeeper’s workshop project plans, search for “workshop”.

# *"In the Beekeeper's Work Shop"*

## *Building a Bee Hive: The Inner Hive Cover*

©by Stephen E. Tilmann

### List of Materials: Inner Cover

#### WOOD

			Reference Figure
A	Frame Sides (2)	3/4 x 1-1/2 – 18-3/8	3
B	Frame Ends (2)	3/4 x 1-1/2 – 16-1/4	3
C	Cover (1)	14-3/4 x 18-3/8 – 1/4	7

#### HARDWARE

1-1/2" nails for assembling frame  
 1/2" staples  
 Franklin's Titebond® Glue  
 Paint

### Cutting Diagram: Inner Cover

**1 Sheet (48" x 96" of 1/4"- Plywood or Hardboard (Tempered Masonite®))**

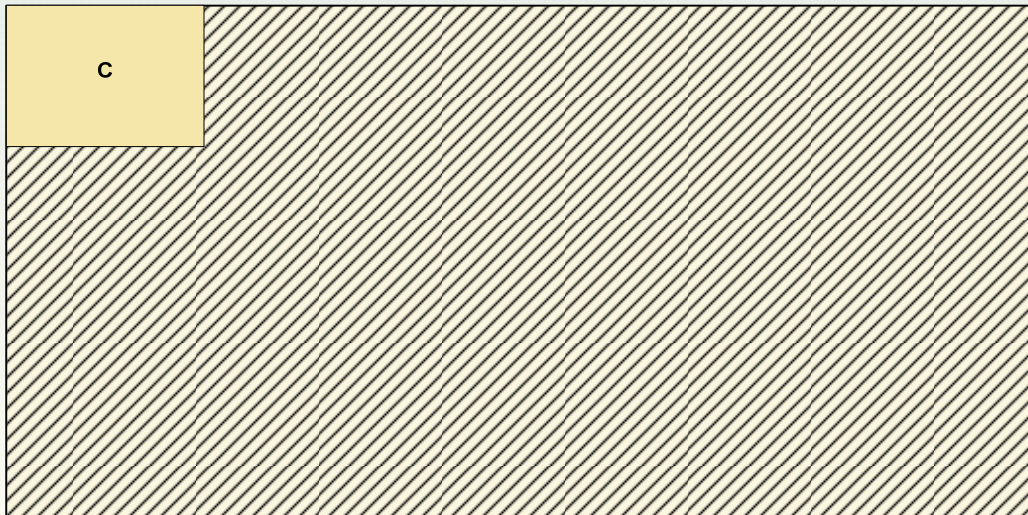

**3/4" x 3-1/2" - 96" (1X4 Pine)**



Note: 15 cover inserts (Piece D) per 4' x 8' sheet when oriented as shown.

Sizes for Inner Hive Cover Components					
	Inner Cover Size (Assembled)		Frame, Length (in)		Cover Insert (in)
	Width (in)	Length (in)	A	B	C
5 - Frame	9-1/4	19-7/8	18-3/8	9-1/4	7-3/4 x 18-3/8
8 - Frame	13-3/4	19-7/8	18-3/8	13-3/4	12-1/4 x 18-3/8
10 - Frame	16-1/4	19-7/8	18-3/8	16-1/4	14-3/4 x 18-3/8

# *"In the Beekeeper's Work Shop"*

## *Building a Bee Hive: The Inner Hive Cover*

©by Stephen E. Tilmann

### Photo Gallery...

---



#### **Photo Captions:**

1. Detail of rebate joint on frame.
2. Rebate joint being assembled.
3. Nailing the frame.
4. Inserting the cover; note glue along the ledge.
5. Stapling the cover to the frame.