

# *"In the Beekeeper's Work Shop"*

## *Building a Honey Extractor Stand*

©by Stephen E. Tilmann

## A Honey Extractor Stand

Sooner or later even a hobbyist beekeeper will consider the purchase of a honey extractor. These gadgets are well worth the investment.

When I first started beekeeping, I was fortunate enough to be able to borrow a small 2-frame tangential hand crank extractor. It did not take too many seasons before I realized the a manual extractor is a real bottle neck when harvesting honey, particularly if you have - or think you might have - more than a couple of hives.

On the plus side, a motorized extractor is certainly convenient. You can load it up, turn it on and then attend to other chores in the honey house. A motorized extractor probably also does a better job of spinning out the honey. I usually spin for 10 minutes, starting at a slow speed and then revving it up as the minutes go by. Frames almost always are completely spun out at the end of the cycle.

On the down side, a motorized extractor will cost some of your hard-earned honey money. For many beekeepers, the extractor will be the single most expensive piece of equipment they have.

All extractors have a stand which can be purchased sepa-

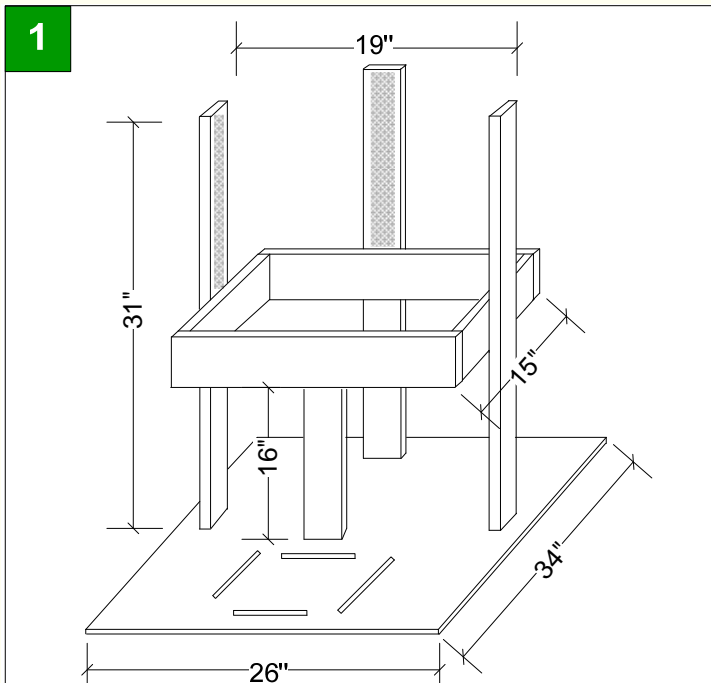

1  
The extractor stand is constructed using a 2x4 framework on an OSB base. A piece of hardboard (not shown) sits on the shelf to support the extractor. This insides of the uprights are covered with a strip of carpet to pad the extractor. Cleats on the bottom to hold the honey bucket in place and hooks on the uprights for securing the extractor complete the project.

rately. However, an excellent honey extractor stand can be inexpensively built in your work shop in just a few hours and it will give good service (see photo).

At the very beginning of the spin cycle, the extractor will probably shake and wobble as the frames are not always in balance. This can present quite a strain on a stand, so it should be strong enough to withstand the vibrations.

When using the extractor, I place a 5-gallon gated honey bucket under the extractor's open honey gate to continually drain the honey. However, when spinning a particularly out-of-balance load, the extractor will have a tendency to "walk". If you don't keep an eye on things, the stand can walk right out from under the bucket and honey will run all over the place!

This is easy to do (voice of experience), particularly when you get busy decapping the next load of frames or otherwise distracted. To prevent this, the plans provide for a set of small cleats on the base. These cleats will keep the bucket under the extractor's drain and you away from the mop.

Finally, most motorized extractors will provide some

# *“In the Beekeeper’s Work Shop”*

## *Building a Honey Extractor Stand*

©by Stephen E. Tilmann

means of securing the extractor to a stand. I use a 6-frame motorized Ranger from Dadants. This unit has two stainless steel straps that are bolted to the top cover of the extractor. To hold the extractor in place, you can use a turnbuckle to secure the straps to a screw-in hook on the uprights of the stand. If your extractor has a different arrangement (such as bottom clips), then these plans will have to be modified slightly for your individual situation.

### **Basic Construction**

The honey extractor stand is basically a 4-legged shelf constructed out of 2x4s (Figure 1). Three of the legs extended above the shelf to hold the extractor in place. The stand is

secured to a base of 1/2-inch OSB board or plywood. Four small cleats are attached to the base to keep the honey bucket in place. A piece of hardboard is placed on top of the shelf to support the extractor.

Three narrow strips of carpeting are stapled to the insides of the supports above the shelf to provide padding around the extractor.

And finally, two screw-in hooks and turnbuckles on the front of the side supports are used to hold the extractor firmly in place during operation.

With a fresh coat of paint, the extractor is not only easy to keep clean, it also looks good in the honey house.

## **Before You Begin...**

The plans presented are for a 18” diameter Ranger extractor (from Dadants). If your extractor is different, then these plans may have to be modified to accommodate your extractor’s diameter. The shelf should be 1 inch wider than the extractor’s diameter and about 3 inches narrower than the diameter. In the plans presented, the shelf is 19” wide and 15” deep.

If your extractor is 14 inches in diameter, then the shelf should be reduced in size to 15 inches wide and 11 inches

deep. A 24-inch diameter extractor would have a shelf 25 inches wide and 21 inches deep; the base would probably be a bit bigger as well.

Anything above a 24-inch diameter extractor is a serious piece of equipment and probably too big for the stand described in this article.

## **Construction Details**

### **Step 1. Make the Shelf Bracket Assembly**

For the shelf bracket, cut two 19” long pieces and two 12” long pieces from a 2x4. Then glue and clamp the four pieces into a simple box (Figure 2). Use two 3” dry wall screws on each end. Check for square.

From a scrap piece of hardboard (tempered Masonite®), cut a 15” by 18-3/4” shelf. This goes on top of the shelf bracket and does not need to be secured.

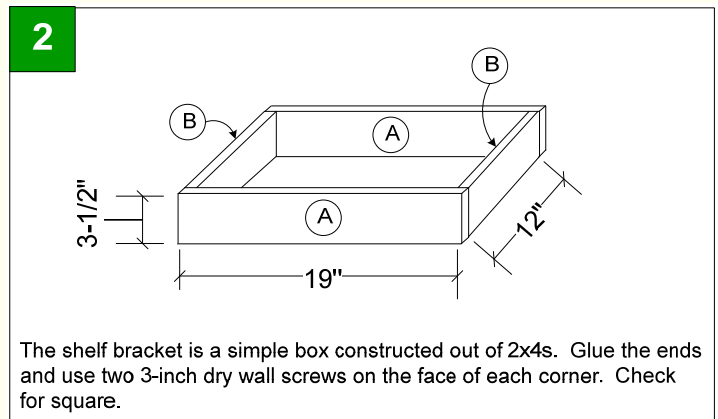

# "In the Beekeeper's Work Shop"

## Building a Honey Extractor Stand

©by Stephen E. Tilmann

### Step 2. Attach the Stand Legs

For the stand legs, cut three 31" pieces and one 19-1/2" pieces from 2x4. Then attach the four vertical legs to the shelf support (Figure 3).

The legs will extend 16" below the bottom of the shelf bracket. The top of the front leg will be flush with the top of the shelf bracket. Dry assemble using two 2-1/2 inch dry wall screws per leg. Check for square and make sure the stand will not wobble (bottom of legs should be even).

When satisfied, remove the legs and then reattach using glue and clamps. Again, check for square and wobble.

### Step 3. Make the Base

Cut the 26" x 34" base from a sheet of 1/2" OSB or plywood (Figure 4). Trace out the locations of the four vertical legs. The two side supports and the back support will be 2 inches from the edge of the base. The front edge of the front support will be 17 inches from the front of the base.

Drill two 1/8" pilot holes in each of the traced locations for the four support legs. Set the stand upside down and screw on the base with 2" dry wall screws using the pilot holes as your guide. Gluing the legs to the base will help keep things tight.

From a scrap piece of hardboard (tempered Masonite®), cut a 15" by 18-3/4" shelf. This goes on top of the shelf bracket and does not need to be secured.

### Step 4. Install the Bucket Cleats

To keep the bucket in place, screw to the base four 1" x 8" cleats cut from a scrap 1x4. Position the cleats so that there is about a 1-inch (or more) clearance around the bucket when the bucket is placed underneath the drain on your extractor (Figure 4). The location of the cleats is not crucial so you can position by eye. Screw the cleats in from the bottom to hide the 1-inch drywall screws.

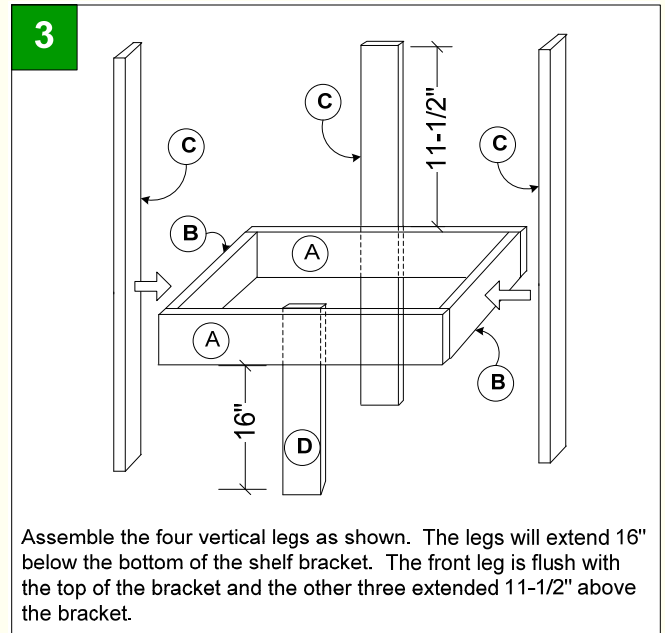

Assemble the four vertical legs as shown. The legs will extend 16" below the bottom of the shelf bracket. The front leg is flush with the top of the bracket and the other three extended 11-1/2" above the bracket.

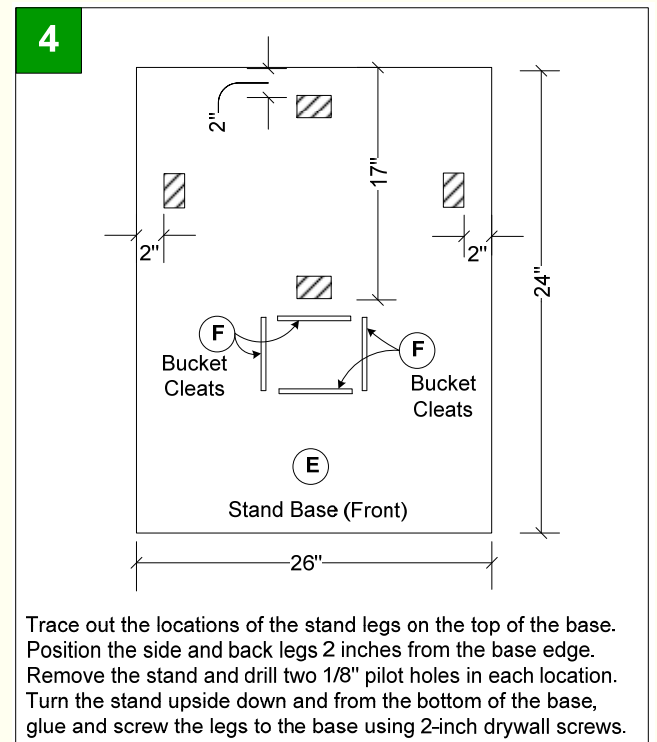

Trace out the locations of the stand legs on the top of the base. Position the side and back legs 2 inches from the base edge. Remove the stand and drill two 1/8" pilot holes in each location. Turn the stand upside down and from the bottom of the base, glue and screw the legs to the base using 2-inch drywall screws.

### Tip

The extractor stand makes a convenient place to store your extractor during the off season. Place all of the miscellaneous extractor parts (bolts, washers, wing nuts and controller) inside the extractor so these won't get lost. To keep clean, cover the entire extractor with a drum-size plastic trash bag.

# *"In the Beekeeper's Work Shop"*

## *Building a Honey Extractor Stand*

©by Stephen E. Tilmann

### **Step 5. Paint the Stand**

Now is the time to paint the stand. Use a primer and two top coats of a good grade latex paint. Be creative and add a splash of color to your honey house.

### **Step 6. Install Padding Strips**

The extractor will almost certainly vibrate and shake when you use it. To prevent scraping on the inside of the vertical supports, tack or staple a 2" x 10" strip of carpet to the inside of the three supports above the shelf (Figure 5).

### **Step 7. Install Clamp Hooks**

To hold the extractor in place, you will need a 2-inch "S" hook, a 4-inch turnbuckle and a screw hook for each side (see Figure 2 in the Photo Gallery). Place your extractor on the stand and connect the hardware to the extractor's straps. Be sure to have the turnbuckle about half-way extended. Locate the position on the front of each vertical side support for the screws hooks and attach. Drill a 1/4" pilot hole to avoid splitting the support.

Test the turnbuckle assembly to make sure you have enough adjustment to securely hold the extractor in place.

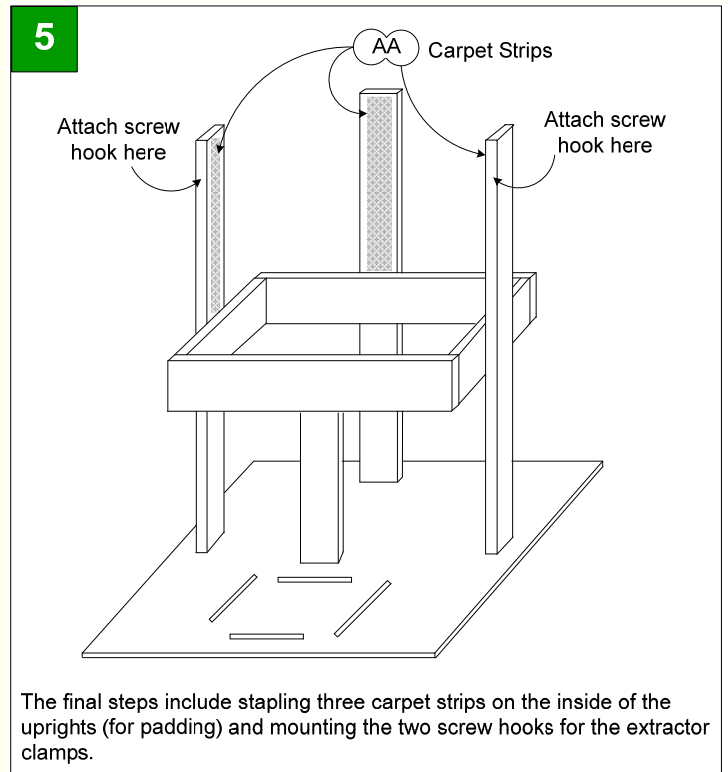

# "In the Beekeeper's Work Shop"

## Building a Honey Extractor Stand

©by Stephen E. Tilmann

### List of Materials: Honey Extractor Stand

#### WOOD

			Reference Figure
A	Shelf Support Bracket, Front/Back (2)	19" - 2x4	2
B	Shelf Support Bracket, Sides (2)	12" - 2x4	2
C	Stand Legs, Sides/Back (3)	31" - 2x4	3
D	Stand Leg, Front (1)	19-1/2" - 2x4	3
E	Base (1)	26" x 34" - 1/2" OSB or Plywood	4
F	Bucket Cleats (4)	1" x 3/4" - 8"	4
G	Shelf (1)	15" x 18-3/4" - 1/4" Hardboard	(not shown)

#### OTHER

AA	Padding Strips Cut from Carpet (3)	2" x 10"	4
----	------------------------------------	----------	---

#### HARDWARE

- 3" drywall screws (8, or as needed)
- 2-1/2" drywall screws (8, or as needed)
- 3" Screw Hooks (2)
- 4" Turnbuckle (2)
- 2" S-Hook (2)
- Franklin's Exterior Titebond® glue
- Latex Paint (primer and top coat)

Note: Sizes shown are for a 16" diameter honey extractor

### Cutting Diagram: Honey Extractor Stand

#### 1-1/2" x 3-1/2" - 96" (2X4 Pine)

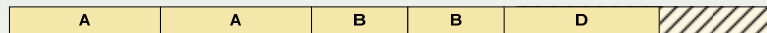

#### 1-1/2" x 3-1/2" - 96" (2X4 Pine)

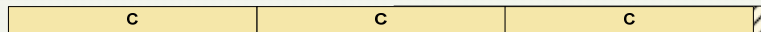

#### ALSO NEED...

- 18-3/4" x 19" SHELF CUT FROM SCRAP PIECE OF 1/4-INCH HARDBOARD (TEMPERED MASONITE )
- 26" X 34" BASE OF 1/2-INCH OSB OR PLYWOOD
- FOUR 3/4" X 1" X 8" CLEATS CUT FROM SCRAP



# "In the Beekeeper's Work Shop"

## Building a Honey Extractor Stand

©by Stephen E. Tilmann

### Photo Gallery...

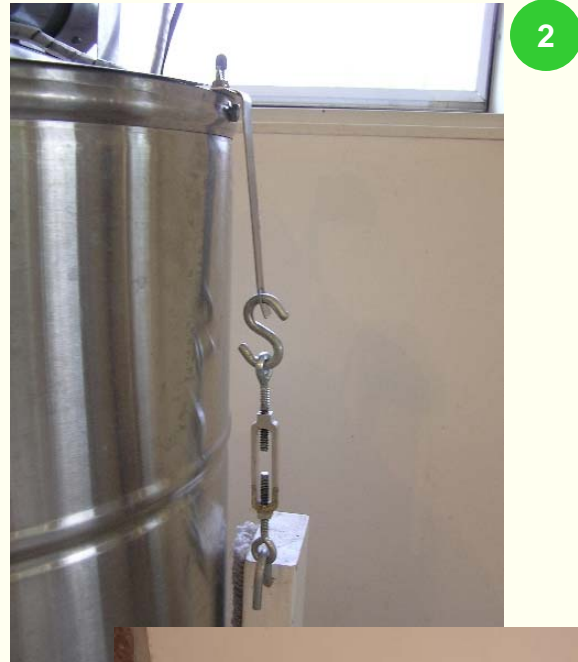

#### Photo Captions:

1. Extractor stand ready for use.
2. Detail of tie-down hardware.
3. Detail of hook and carpet padding
4. Complete extractor stand.