



SHOP NOTES

Magna Engineering Corp.,
417 Montgomery Street,
San Francisco, California

No. 1 & No. 2

INTRODUCTION

SHOPSMITH **Shop Notes** are a special service feature to SHOPSMITH owners. While they will supplement information in the Owner's Guide, they are intended principally to keep SHOPSMITH owners up to date on the latest ideas and suggestions for new SHOPSMITH uses. As ideas are collected and tested, they will be sent you in periodic issues of SHOPSMITH **Shop Notes**.

If you have discovered new SHOPSMITH uses which you think may benefit others, please describe them and we shall try to include them in later SHOPSMITH **Shop Notes**. We should be pleased to receive photographs and sketches illustrating your ideas.

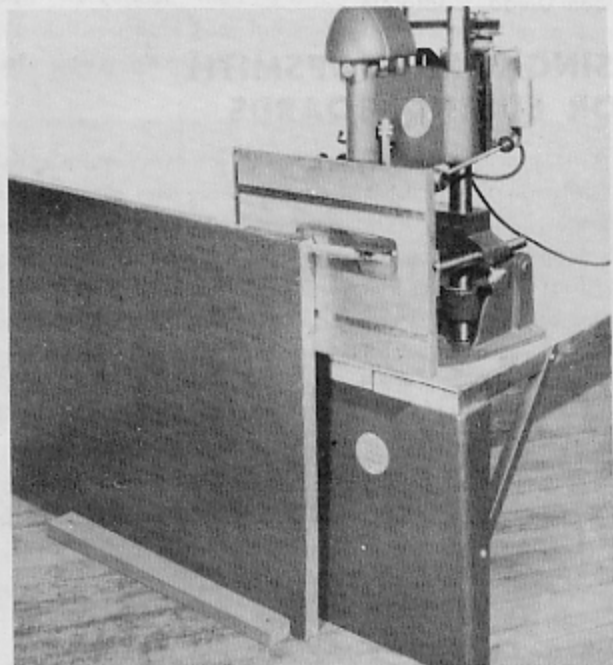

VERTICAL SAWING OF LARGE WORKPIECES

Here is an application of SHOPSMITH for sawing extra wide, extra long or heavy and unwieldy pieces of work, simply by using the tool in the vertical position.

Adjustments are quick and accurate and give, for all practical purposes, an unlimited capacity for easily handling work of any length and width.

Slide the headstock and table to the approximate location in the horizontal position, and then swing vertically. Fine adjustments can be made in the vertical position by extending the quill. (It is possible to run the blade "above" the table for cuts in excess of 2 1/4".) Depth of cut is set by adjusting the table rods in the carriage holes exactly the same way as in the horizontal position.

If the floor of your workshop is level, all cuts will be true and accurate. However, if the floor is not perfectly level, you can simply construct a narrow wooden platform of any desired length on which to nail the guiding cleats to slide the workpiece.

Try using this set-up whenever you have work too heavy or unwieldy to handle with SHOPSMITH in the horizontal position.

UNLIMITED VERTICAL DRILLING CAPACITY

This photo further illustrates the versatility and unlimited capacity of SHOPSMITH. The door shown in the illustration is being mortised for a lock set. Note that the table serves as a jig to align the door directly under the chisel. For drilling or mortising other large or awkward pieces such as furniture, the same procedure can be used to great advantage.

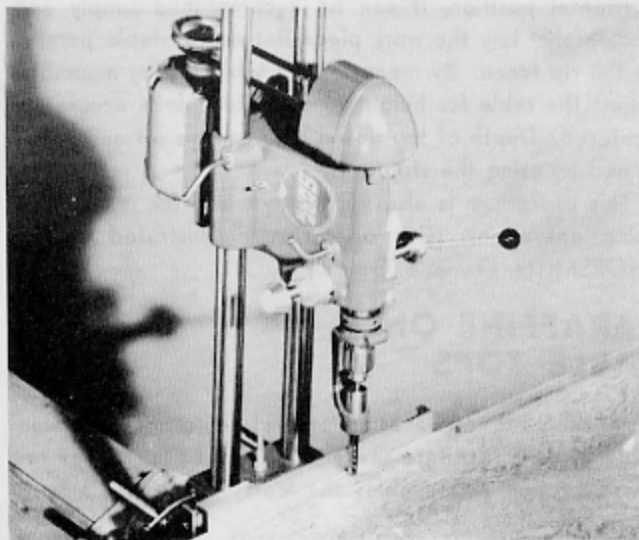

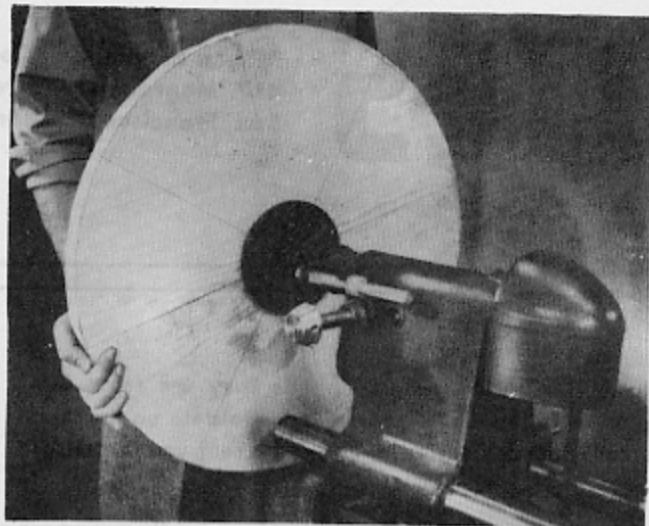

OUTBOARD TURNING

Workpieces with diameters in excess of 15", such as wooden trays, stool and table tops, etc., can be "out-board" turned on your SHOPSMITH simply by:

- (a) Removing tie bar from headstock end of the tubular ways.
- (b) Removing the headstock, turning it around and replacing it on the tubular ways.
- (c) Clamping headstock near the headrest so that the work piece hangs over the end of the tubular ways.

It is not necessary to replace the tie bar when the headstock is on the end of the tubular ways.

A simple floor stand with a T-bar for tool rest can be constructed from lumber or preferably pipe. Height should be approximately that of center of work piece and tool rest should be level.

DRILLING FOR DOWELS

Drilling a dowel hole in the edge of a narrow board is an extremely difficult operation to perform by hand on an ordinary drill press. Using SHOPSMITH in the horizontal position, it can be accomplished simply and accurately. Lay the work piece flat on the table parallel to the rip fence. By means of the table raising assembly, adjust the table for height so that the hole is accurately centered. Depth of the dowel hole can be set and maintained by using the stop nuts.

This procedure is also very convenient for many mortising operations. (This operation is illustrated in the SHOPSMITH Owner's Guide.)

PARAFFINE ON TABLE TOPS

Paraffine rubbed on SHOPSMITH table and extension table top will facilitate sawing. The light film of wax reduces friction and enables the workpiece to be moved more smoothly.

CASTERS ON BENCH

If space limitation necessitates placing your SHOPSMITH against a wall, you may find it convenient to mount one end on casters to facilitate swinging the unit into the room for sawing long pieces of wood. Castering one end is usually sufficient since the bench can then be handled "wheel-barrow" style.

It is preferable to use "disappearing" casters so that the bench legs are firmly on the floor when SHOPSMITH is being operated. This can be accomplished by any of several means. One method is to mount the casters on a small board which is hinged to the bottom of the legs. By slightly lifting the end of the bench the casters can be placed in position or removed.

Stove type casters can also be used. These can be placed under each bench leg for movability and then removed when the SHOPSMITH is to be operated. This idea was first suggested by SHOPSMITHER R. E. Hatcher of San Diego, California.

USING THE SHOPSMITH FOR EDGING BOARDS

Work pieces may be edged (or "jointed") quite satisfactorily on the SHOPSMITH by using the disc sander and the rip fence. With the SHOPSMITH set up in the disc sander position, adjust the fence at a distance from the disc slightly less than the width of the piece to be edged or jointed. The work may then be fed across the table between the sanding disc and fence. By loosening the fence adjustment screws, the fence can be set at a slight angle to the disc, and the work piece fed directly through from the rear.

If short pieces are to be finished to the same width, butt one end against the fence with the edge to be faced slightly overhanging the table edge. The sanding disc is then fed into the work with the feed lever. Set the lock nuts on the depth of stroke rod to control exact distance.

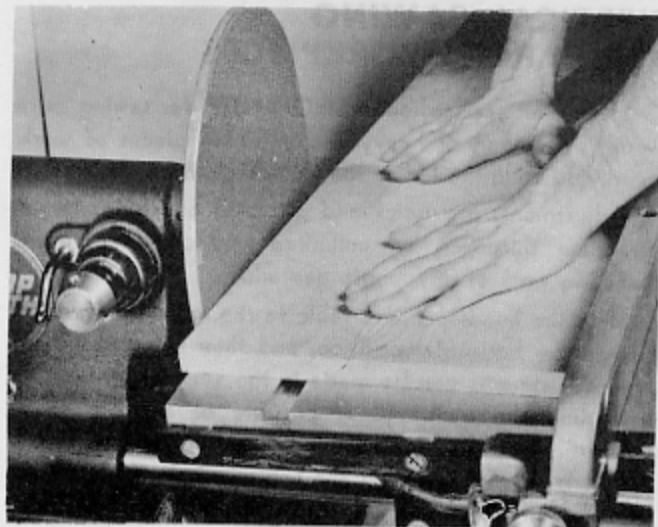

SHOPSMITH IDEAL FOR THE DISABLED VET

Robert Aigner of Van Nuys, California, is a typical example of the physically handicapped who are finding great enjoyment and usefulness in woodworking with SHOPSMITH.

After nearly four years in the army, Bob was wounded in a battle near Metz on the French-German border, and as a result of his injury he is paralyzed from the upper part of the waist down.

While convalescing, Bob made a resolution to have his own workshop. After settling down in a little home in Van Nuys, he immediately began converting the garage to a woodworking shop. He was determined to have power tools, but lack of space, inconvenience of moving, and the need for several motors made single-purpose tools impractical. Then he discovered SHOPSMITH, and this multi-purpose tool fulfills his requirement for a complete power workshop.

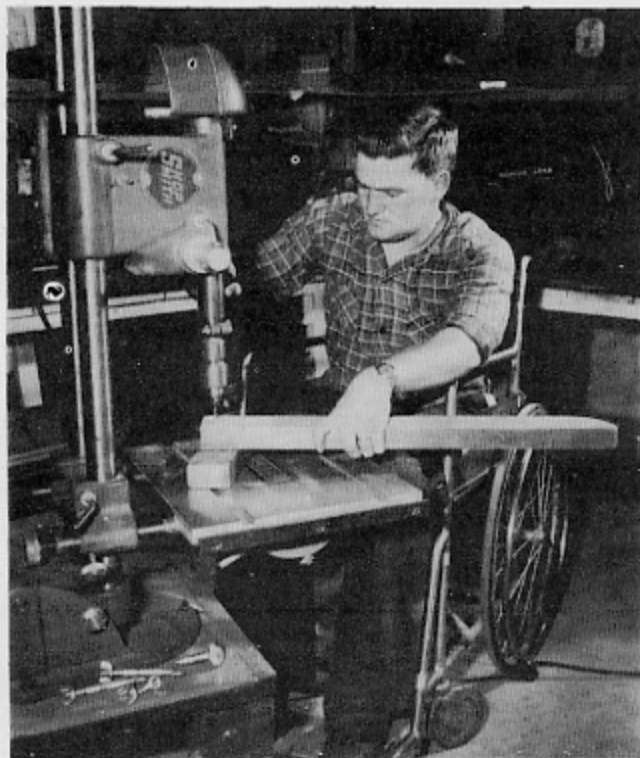

USING THE SHOPSMITH AS A GLUE PRESS

When SHOPSMITH is in the vertical position, it can be used as a press for light gluing jobs. Secure the 6" lathe face plate to the spindle and place work to be glued on the table directly below the face plate. Then lower face plate with the quill feed lever and clamp against work by tightening the quill lock lever. It is preferable to place a flat board or piece of plywood on the metal table beneath the work piece being glued.

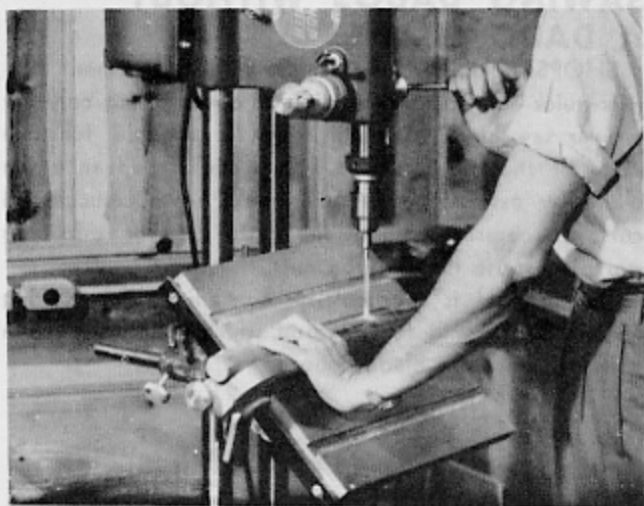

AUTOMATIC "V" BLOCK

When a "V" block for drilling round work pieces is required, do not waste time constructing a special jig. Simply tilt the SHOPSMITH table to approximately 45° (while in the vertical position) and use the rip fence as the other half of the "V." A WORD OF CAUTION: As the drill leaves the work piece, it will hit the fence or table. Therefore, place an additional piece of wood against the fence or table.

USING A PUSH STICK

When ripping narrow work under 5 or 6 inches, always use a push stick between the saw and fence to advance the work past the SHOPSMITH blade. Make two or three push sticks of the shape indicated in the accompanying sketch, and hang in a place convenient to the saw. To use the stick, start ripping the work in the usual manner and use the push stick for continuous feeding when the cut is about 8 inches from the end of the board.

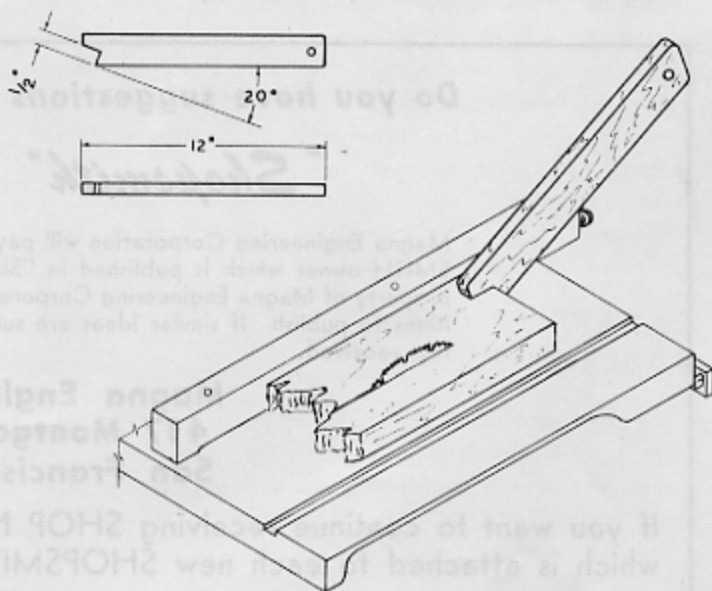

SAWING DADOS WITHOUT A DADO BLADE

SHOPSMITH'S exclusive micro-blade adjustment permits quick and accurate cutting of dados, using only the regular saw blade. Use the fence as a guide for one edge of the dado groove. Then slightly advance the blade by extending the quill; make several successive cuts. To control width of the dado cut for duplicate workpieces, use the stop-rod nuts.

This method is particularly convenient for sawing narrow dados, and for plywood which splinters when a conventional dado blade is used.

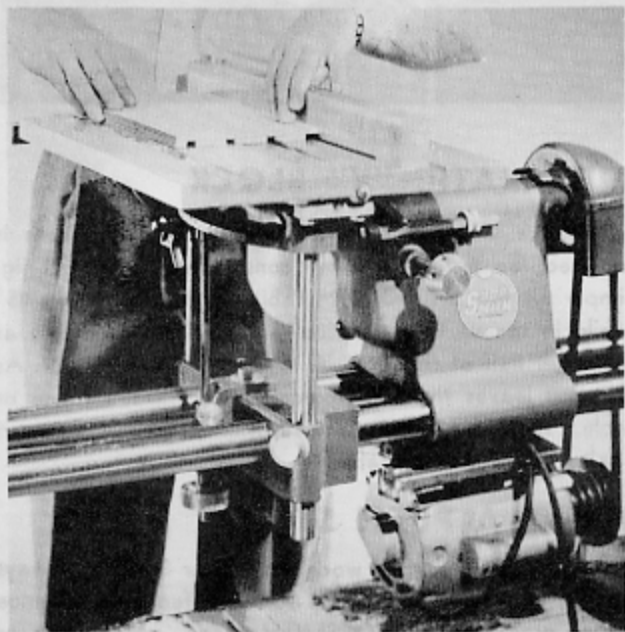

CUTTING DUPLICATE PIECES

Quite often it is desirable to saw two or more pieces of wood to the same length. On the SHOPSMITH this can be done by clamping a small wooden stop to the fence. This stop should be placed so that the leading edge of the workpiece is in line with the beginning of the saw cut. The fence with block is then set at the required length. The stop will insure an accurate setting for the start of the cut without binding the piece as it is sawed.

ALLEN WRENCHES

Having trouble keeping track of your Allen wrenches? They will always be on hand if you drill two holes in your bench top near the headstock end and keep them there. A hole drilled near the base plate end of your bench top will be a convenient location for your chuck key.

Do you have suggestions for

"Shopsmith" Shop Notes ?

Magna Engineering Corporation will pay \$5.00 for each idea submitted by a SHOPSMITH owner which is published in "Shop Notes." Ideas received will become the property of Magna Engineering Corporation, who will also be the final judge of which items to publish. If similar ideas are submitted, payment will be made only for the first received.

**Magna Engineering Corp.,
417 Montgomery Street,
San Francisco, California**

If you want to continue receiving SHOP NOTES, be sure you return the Warranty Card which is attached to each new SHOPSMITH it files your correct address.