



Woodsmith **PLANS**

# TABLE SAW RIPPING JIG



# TABLE SAW RIPPING JIG

*Cutting thin strips can be a real challenge. These tips and techniques will guarantee safe, accurate results every time.*



**I**t seems like many of the projects I build call for thin strips of wood. Sometimes it's several thin strips to glue up into a bent lamination, and sometimes it's just a few strips to act as dividers in a small drawer. Even if all I need are a couple strips to cover up some plywood edges, cutting them on the table saw can be a challenge.

No matter what your need, the goal is to get the best results with accuracy and safety in mind. The nice thing is, all this takes is the right setup, a handy jig, and a few simple tips and techniques.

## START WITH THE BLADE

One thing about ripping thin strips that's often overlooked is the saw

blade. In most cases, a standard combination blade will give you great results. If this is the blade you use for most of your work, I'd stick with it. But there are a couple of other blades you may want to consider.

**SPECIALTY SAW BLADES.** The saw blades in the photos at the lower left address a couple of thin strip issues. The far left blade is specifically designed for making rip cuts that result in surfaces smooth enough to glue up. Well, one of the main goals of ripping thin strips is to end up with a workpiece that's smooth and free of blade marks and burning. And Freud's Glue Line Rip blade gives you just that. This can be a real advantage when it comes to gluing up



◀ **Saw Blade Options.** A specialized ripping blade (far left blade) makes for smoother strips and faster cutting. Using a thin-kerf combination blade will result in more strips per workpiece.

strips into a bent lamination. If you have to cut extra-thick strips and then plane or sand them smooth, your bent lamination may not end up looking like a single piece of wood. The glue line rip blade ensures that the only material you “lose” is the thickness of the saw kerf.

**THIN KERF.** The thin-kerf blade shown on page 1 can also result in less waste. With a thickness of  $\frac{3}{32}$ " , you get one extra thin strip for every four you cut (for  $\frac{1}{8}$ "-thick strips). This can save you a fair amount of material if you have a lot of thin strips to cut.

**INSERT.** Regardless of the saw blade you decide to use, you'll want to install a zero-clearance insert with a built-in splitter. The one I use is shown in the box below. Besides preventing the thin strips from falling between the insert and blade, the added splitter keeps the strips from pinching the saw blade and kicking back.

### SETTING UP FOR THE CUT

With your saw blade and new insert installed, you're just about ready to start cutting strips. But to get the best results, it's a good idea to make sure the saw is tuned up.

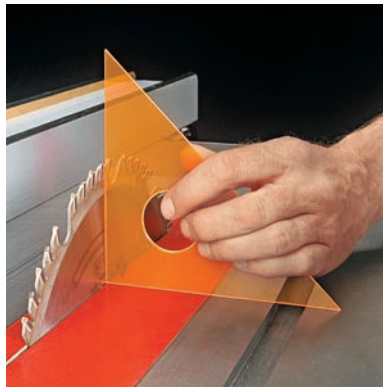

▲ **Set the Blade to 90°.** A drafting triangle makes it a snap to square the saw blade to the table.

And this is just a matter of checking a couple key settings.

**SQUARE THE BLADE.** The first thing to take a look at is the blade angle. You want to make sure the saw blade is set at a perfect 90° angle to the table (photo above). The reason for this is simple. A slight tilt to the blade will result in a strip that's thinner along one edge than the other. This can cause problems if you glue up a set of strips like this for a bent lamination.

**RIP FENCE.** The other setting you'll want to check has to do with the rip fence. If the fence isn't parallel to the



▲ **Dead-On Fence.** A dial indicator makes it easy to check the front and rear of the rip fence and ensure that it's parallel to the miter slot (and the saw blade).

saw blade, you'll get blade marks and burned edges as well as an increased risk of kickback. A simple dial indicator makes quick work of ensuring your rip fence is set right (photo above). With the saw set up, you're ready to turn the page and start ripping thin strips with ease.

## ZERO-CLEARANCE INSERT & SPLITTER

A zero-clearance insert with a splitter is one of the big keys to successfully ripping thin strips. The insert prevents a strip from getting trapped between the blade and the opening. And the splitter keeps the strip from binding on the blade.

To make a new insert for your table saw, you'll need to start with a blank that matches the thickness of your stock insert. (Note: If the material is thinner, you can add screws to the bottom so you can adjust it perfectly flush with the saw table.)

After tracing the outline of the original insert on the blank, cut away most of the waste (Figure 1). Then use a flush-trim bit in the router

table to create an identical insert (Figure 1a).

Ripping a slot in the new insert is just a matter of aligning the fence with the edge of the original insert and making a stopped cut (Figure 2).

Finally, cut a hardwood splitter to size, sand one end to a point, and glue it into the kerf with the point facing the blade (photo at right).

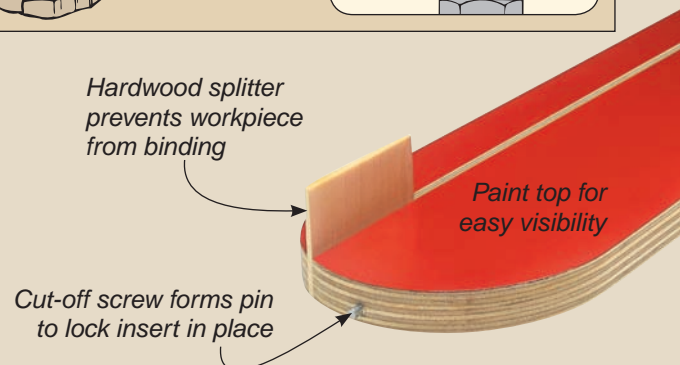
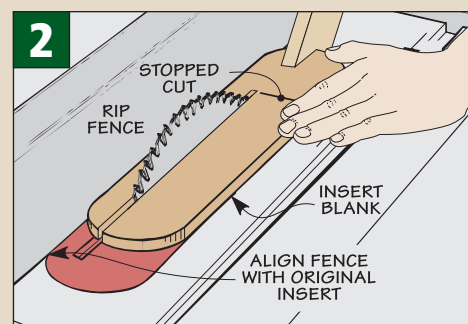
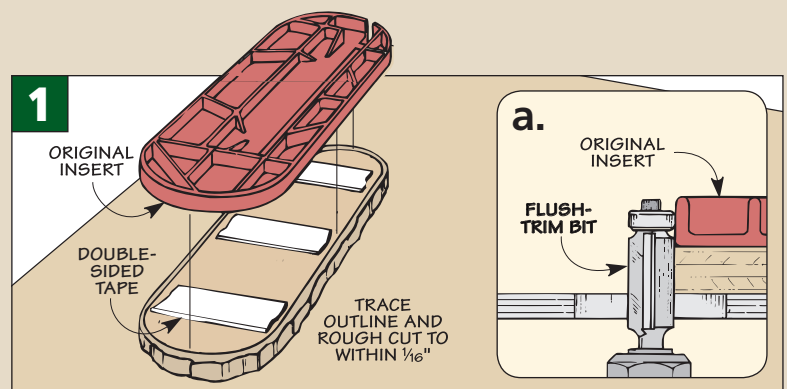

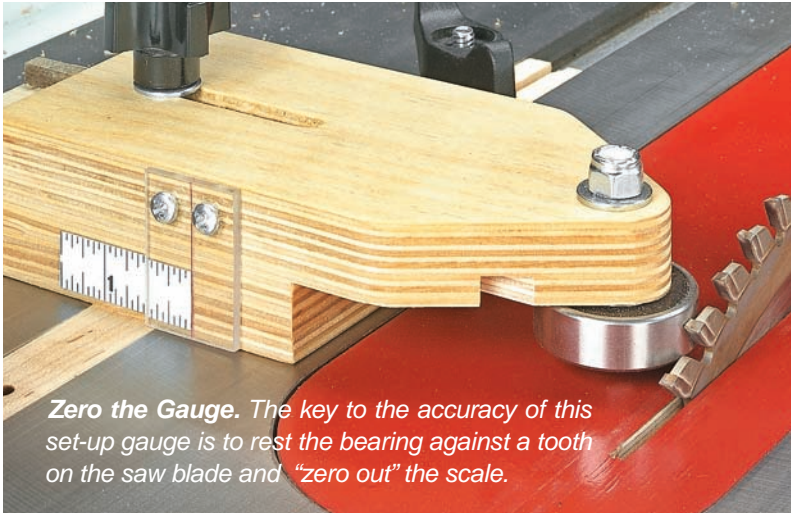

**Zero the Gauge.** The key to the accuracy of this set-up gauge is to rest the bearing against a tooth on the saw blade and “zero out” the scale.



**Ripping a Long Strip.** Position the jig in front of the blade and tighten it in place. Then slide a workpiece up to the bearing, snug up the rip fence on the workpiece, and make the cut.

## How to Rip Thin Strips

Even after truing up your saw and selecting the blade, there’s a little more to ripping thin strips than just setting the fence and cutting. First, I’ll mention a few basic techniques that apply. After that,

I’ll show you the shop-made jig I use to handle cutting thin strips.

### THE BASICS

When it comes to ripping thin strips, one of the most important things to

do before you start is set up some type of outfeed table. The reason for this is simple. Without support, the strips are going to fall off the back edge of the saw table, and I don’t want to give myself any reason to reach over the saw blade and try to catch them. Plus, having them pile up on the floor is just a mess I’ll have to deal with later.

**BLADE HEIGHT.** With an outfeed table in place, the next step is to set the height of the saw blade. What you want is the teeth to just clear the top surface of the workpiece. This way, there’s not too much blade exposed.

**FEED TECHNIQUE.** All that’s left to do is turn the saw on and feed the workpiece through. The main thing is to use a smooth, even feed rate. This ensures the saw blade won’t burn the edges or leave tooth marks.

**THE JIG.** As you can see, this jig locks into the miter slot to the left of the saw blade. A “rub” bearing fixed to the end of a sliding top is used to gauge the thickness of the strips.

The bearing allows the workpiece to slide without binding. By adding a scale and an adjustment slot in the top of the jig, you can

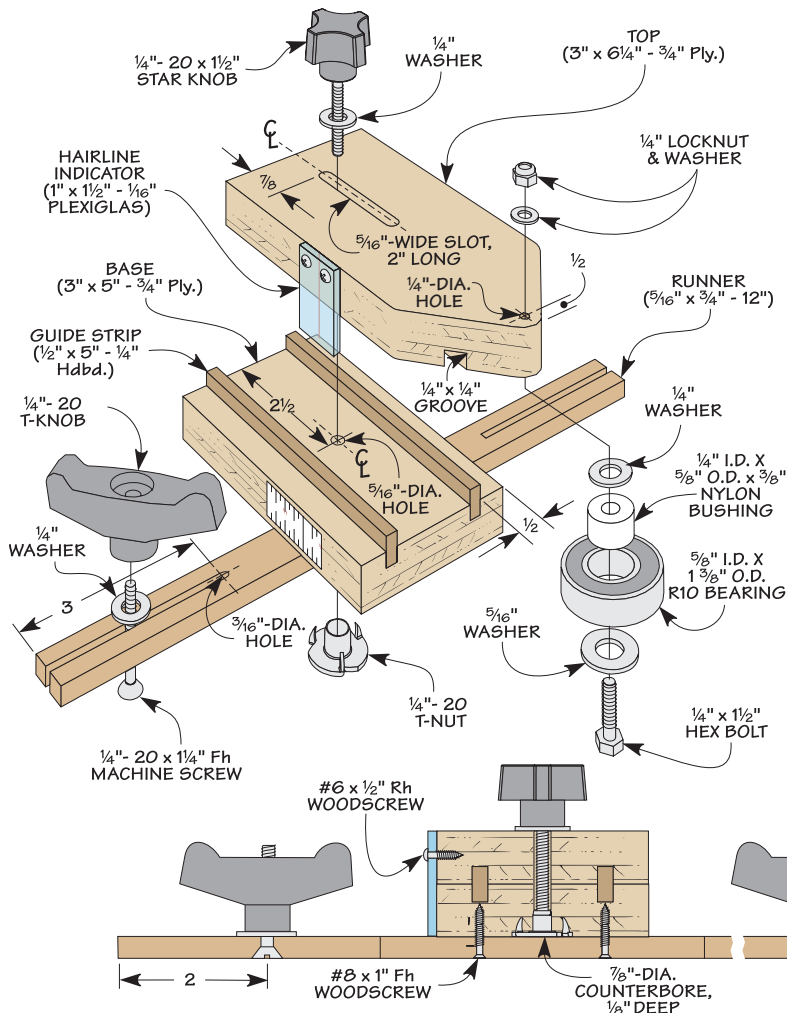

set the exact thickness of the strip you want to rip after zeroing out the gauge (upper left photo on page 3).

**USING THE JIG.** To rip a strip, set the workpiece against the bearing and then slide the rip fence up against the workpiece. After locking down the fence, you can make your cut (upper right photo on page 3). Before each additional pass, just repeat the process. Once your workpiece is down to about 1" wide, it's time to start over with a new one.

There's one last thing to mention. And that's the "look" of your thin strips. To match your needs perfectly, check out the box at right.

## GRAIN ORIENTATION: GETTING IT RIGHT

One of the keys to getting the best-looking strips from a workpiece is to make sure the grain direction is "right." What I mean by this is that it's more important to pay attention to the grain along the edge of a board than it is to the grain on the face.

You can see what I mean by checking out the photo. Even though the face of the board features a wavy, "cathedral" grain, the strips ripped from the edge are actually straight-grained. And that may be important if you're edging plywood with a similar grain. Ripping your edging from a riftsawn or quartersawn board will most likely result in "wild" grain, which may not be the best look for a project.

