

Disk Sander Circle Jig

Creating perfect circles on a disk sander is a snap with this simple jig. Basically, the jig consists of four parts: an MDF base, a cleat, an adjustable hardwood runner, and a pivot pin made from a dowel, see drawing at right.

The base is just a piece of MDF with a groove cut in it for the hardwood runner that holds the pivot pin. This way, you can adjust the position of the pivot pin for different size disks. A cleat is screwed to the bottom of the base to lock the jig into the miter gauge slot in the table of the disk sander.

The pivot pin is just a short length of dowel glued into a hole in the end of the runner. A $\frac{1}{4}$ "-dia. hole is drilled in the underside of the workpiece to allow it to fit over the pivot pin. (Note: If you don't want to drill a hole in your workpiece, you can drill a hole in a small block of wood and attach it to the center of your workpiece with double-sided tape.)

SETUP. Using the sanding jig is a simple process. Start by clamping the base of the jig to the table of the disk sander. Then simply fit the workpiece over the pivot pin and slide the runner forward until the edge contacts the spinning sanding disk. At this point, clamp the runner in place and sand the disk by slowly rotating it clockwise (lower drawing at right).

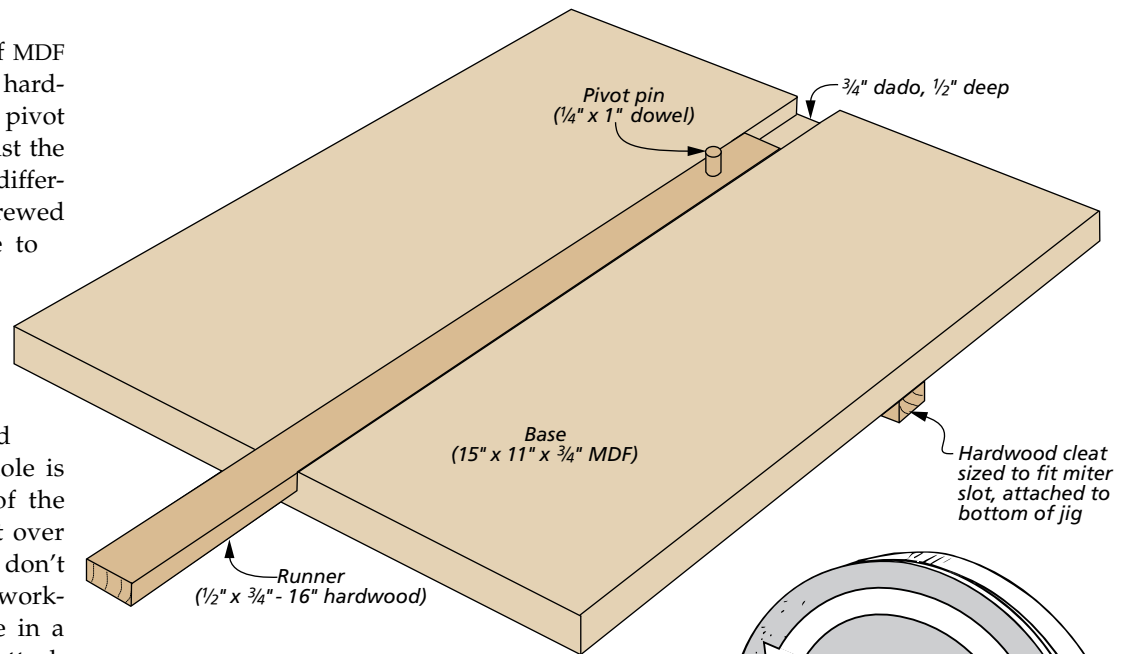

FIRST: Set workpiece in place, then slide runner forward

SECOND: Clamp runner in place, then rotate workpiece

NOTE: Attach cleat so base is $\frac{1}{16}$ " away from disk

