



Woodsmith **PLANS**

PORTABLE DOVETAIL JIG WORKCENTER



DOVETAIL JIG WORKCENTER

Accuracy, convenience, and storage. You get it all with this simple workcenter for your dovetail jig.



The dovetail jig gets a lot of use in my shop. But there are a few things that can be an inconvenience when using it. My biggest complaint is that I have to stoop over to see what I'm doing as I work. Another problem is keeping the workpieces clamped square. And finally, when I'm done for the day, I have to find a place to store the jig and accessories.

The handy workcenter you see in the photo solves all these problems. For starters, it makes a great platform for any dovetail jig. By raising everything to a

comfortable height, it's easier to guide the router. Support bars help keep the workpieces square and position them properly for accurate results.

Plus, there are some other great features. There are "wings" that fold down. They make a handy landing spot to dock your router during use without damaging the bit or your benchtop. And there's plenty of storage in the large drawer down below.

Once you build this workcenter, you'll find that using your dovetail jig is a whole lot easier.

Construction Details

Overall Dimensions:
14" x 28" x 9" (stored size)

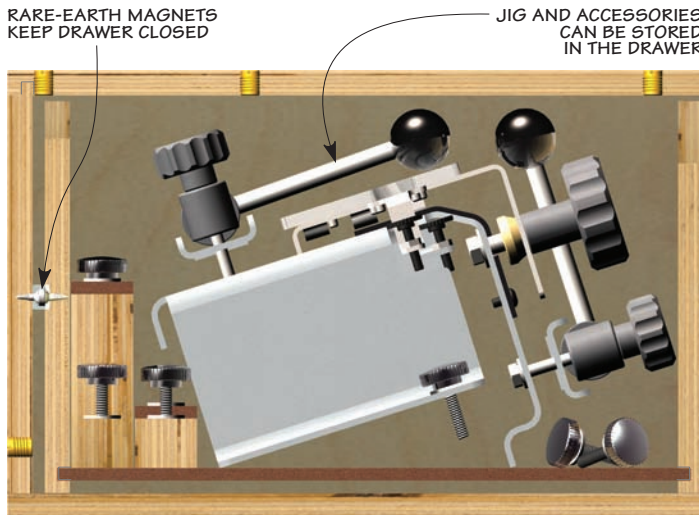
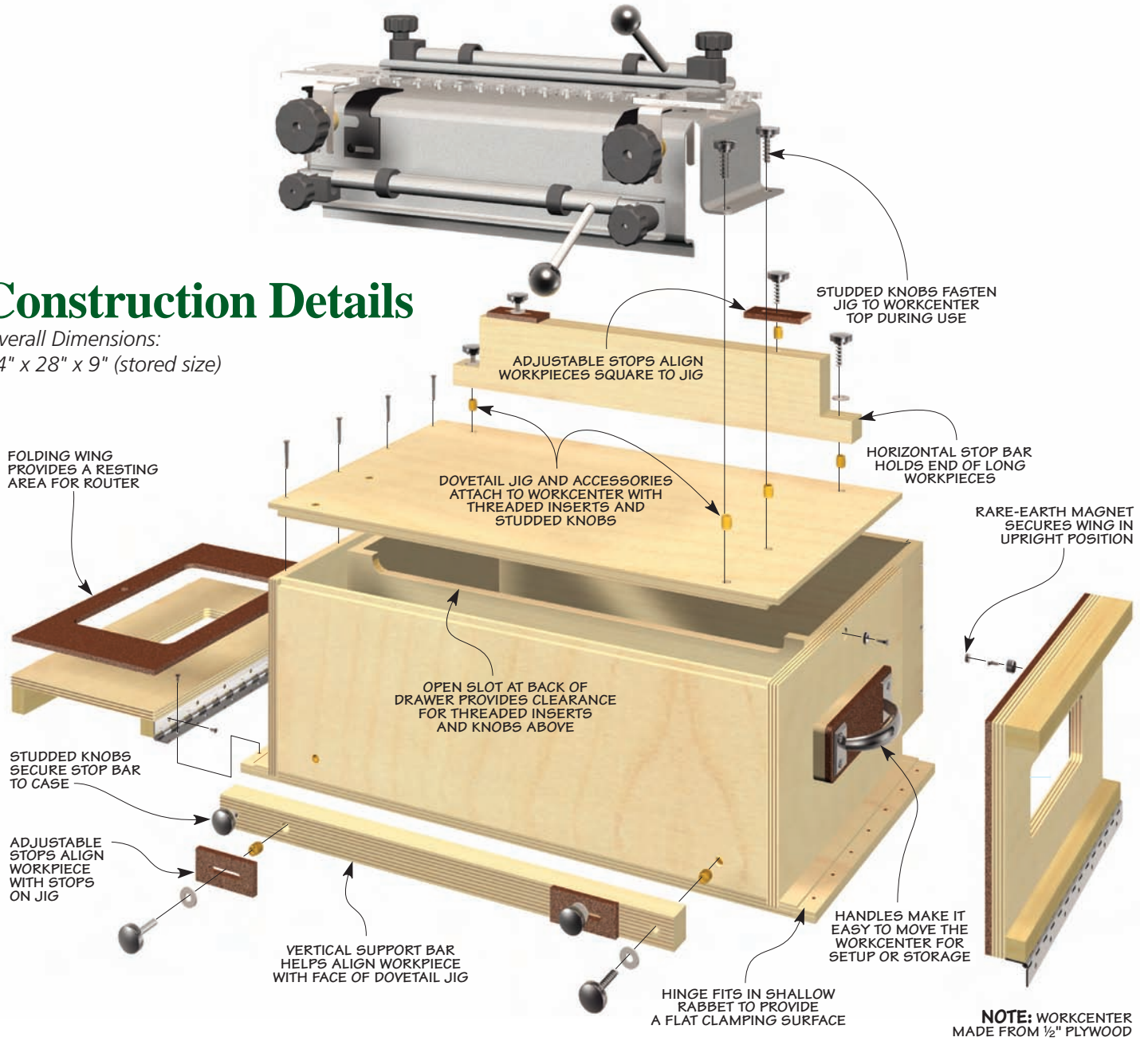

SIDE SECTION VIEW
(DRAWER STORAGE DETAIL)



▲ **Tucked Away.** The large drawer is sized to hold the jig, templates, support bars, and knobs. And with the wings folded up, the workcenter stores neatly away.

Strong & Sturdy Case

In the drawings below, you'll see that the workstation starts out as a simple box. As a matter of fact, it's a lot like a cabinet with a top, bottom, and two sides. But unlike a normal cabinet, the front is a solid panel. And the back is open for the large storage drawer.

For now, you'll concentrate on building the basic box, starting with the sides then adding the top and bottom pieces. Later you'll add the folding wings, a handle, and the storage drawer.

There's one thing you need to know before you get started. My workcenter was sized for the Porter-Cable 4212 dovetail jig. If you have a different jig, you may need to make some adjustments to the size of the case, the height of the support bars, and the drawer.

SIDES. I started on the case by cutting the sides to size. Then you just need to cut grooves for the front panel before moving on to the top and bottom pieces.

TOP & BOTTOM. If you take a close look at Figure 1a below, you can see how the sides of the case fit into dados on the bottom piece and rabbets on the top.



▲ **Compact.** With the wings folded up and the jig inside, you can store the workcenter away.



▲ **Home Base.** The folding wing makes a handy spot for you to set your router when using your jig.

It can be tricky to get these joints to line up so the case ends up square. To get around this problem, I cut the top and bottom pieces to the same size, then cut matching dados in both. The next step is to trim the waste off the ends of the top piece to form rabbets, as illustrated in Figure 1 below.

There are a couple of other things you need to do. First, the top needs a groove along the front edge to capture the front panel (Figure 1b). On the bottom, cut a shallow rabbet on each end for the hinges that will be attached later.

(Here it's a good idea to have the hinges in hand so you can make sure the hinge leaf sits flush.)

FRONT. All you need to do to make the front panel is cut it to size, then rabbet the top and sides to create a tongue. Aim for a snug fit of the tongues in the grooves. Finally, you can assemble the case with glue and screws.

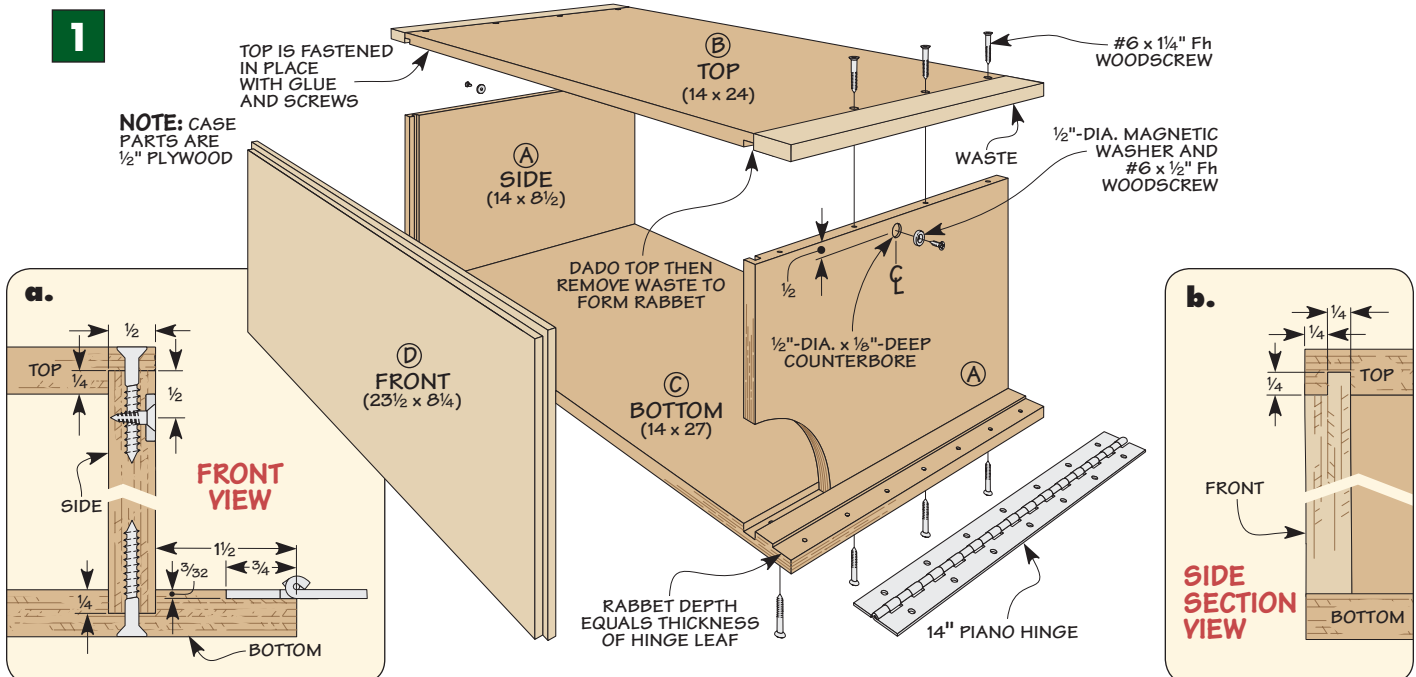

FOLD-DOWN WINGS

With the shell of the case complete, you can start working on the hinged wings at each end.

If you take a look at Figure 2, you'll see that the wings have an opening in the center. These cutouts serve double duty. With the wings folded down, the cutouts make a convenient resting spot for your router. And when the wings are folded up, the cutout provides access to the carrying handle. You'll build the wings first, then fit the handles in the openings, as shown in Figures 2 and 3 at right.

TRAY. The trays for the wings start with a piece of plywood with a center cutout. On top of that is a piece of hardboard with a larger opening sized to fit the base of your router. I cut all the pieces to size first and then cut the openings.

CUTOUTS. To make the cutouts, first drill a hole at each corner. A jig saw makes quick work of "connecting the dots" to remove the waste. With these pieces done, you can glue the hardboard to the plywood and move on to the hinge block and the foot that supports the tray when it's folded down.

HINGE BLOCK. The hinge block is where you'll attach one leaf of the hinge. The goal is to have the tray flush with the top of the case when the wing is in the upright position. I found it easiest to attach the hinge to the case bottom and the hinge block first. Then you can glue the block to the tray.

FOOT BLOCK. The foot block is sized so that the tray sits parallel to the bench when it's in the open position. Just cut the foot block to fit and glue it to the tray.

FINAL STEPS. The last step to completing the wings is to install the rare-earth magnets and washers, as shown in Figure 2.

HANDLES. The handles fasten to a handle block and hardboard spacer (Figure 3). They fit inside the cutouts in the trays. I attached them while the wing was closed so I could position them properly. Finally, you can add the handle.

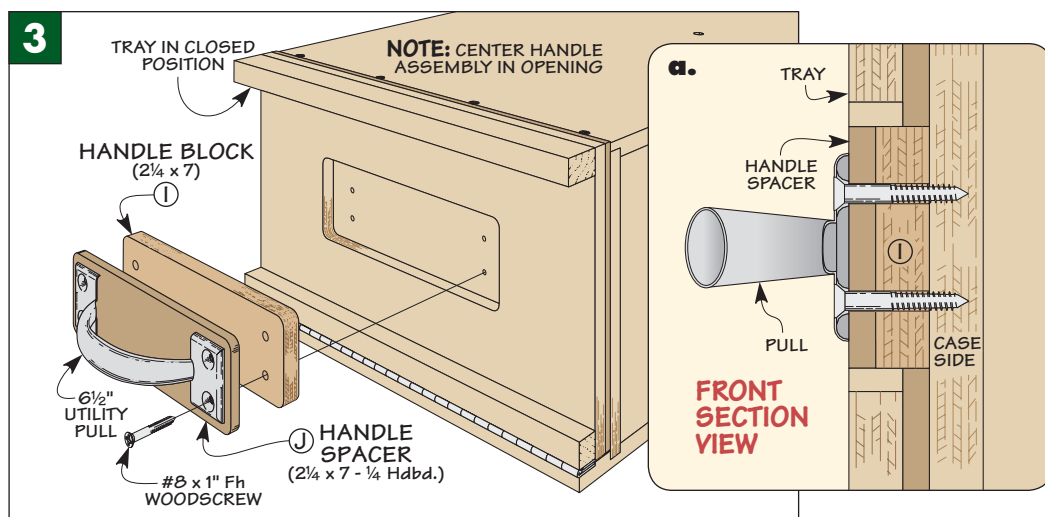
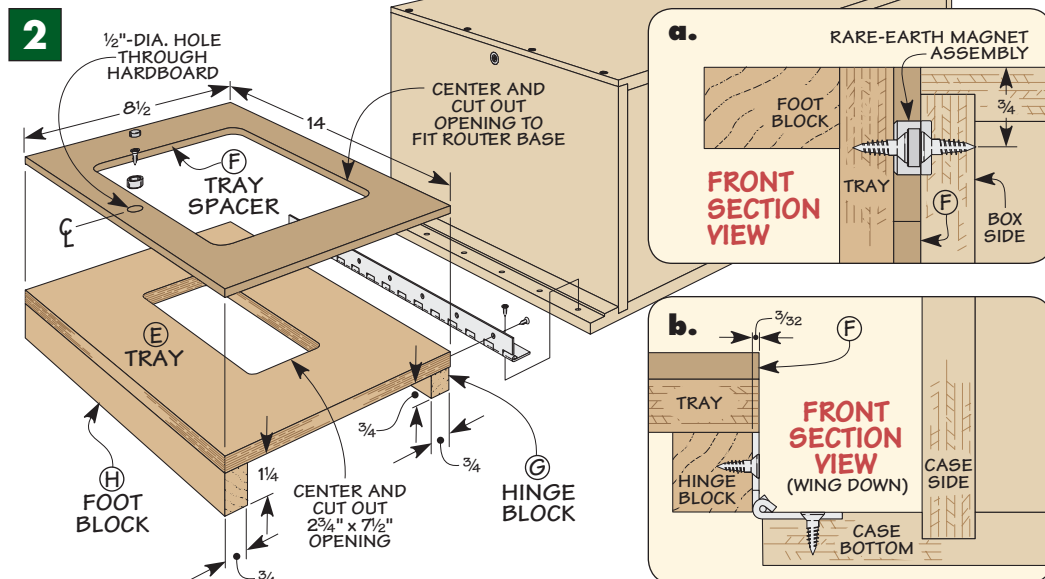

MATERIALS & HARDWARE

A Sides (2)	14 x 8 ¹ / ₂ - 1/2 Ply.	(2) 1/2"-dia. Rare-Earth Magnets w/Cups, Washers, and Screws
B Top (1)	14 x 24 - 1/2 Ply.	(26) No. 6 x 1 ¹ / ₄ " Fh Woodscrews
C Bottom (1)	14 x 27 - 1/2 Ply.	(8) No. 8 x 1" Fh woodscrews
D Front (1)	23 ¹ / ₂ x 8 ¹ / ₄ - 1/2 Ply.	(12) 1/4" Washers
E Trays (2)	14 x 8 ¹ / ₂ - 1/2 Ply.	(8) Round Knobs with 1/4" - 20 x 3/4" stud
F Tray Spacers (2)	14 x 8 ¹ / ₂ - 1/4 Hdbd.	(4) Round Knobs with 1/4" - 20 x 1 ¹ / ₂ " stud
G Hinge Blocks (2)	3/4 x 3/4 - 14	
H Foot Blocks (2)	3/4 x 1 ¹ / ₄ - 14	
I Handle Blocks (2)	7 x 2 ¹ / ₄ - 1/2 Ply.	
J Handle Spacers (2)	7 x 2 ¹ / ₄ - 1/4 Hdbd.	
K Front Stop Bars (1)	1 x 20 ¹ / ₂ - 1/2 Ply.	
L Top Stop Bars (3)	3 ¹ / ₂ x 20 ¹ / ₂ - 1/2 Ply.	
M Adjustable Stops (4)	1 ¹ / ₂ x 2 ¹ / ₂ - 1/4 Hdbd.	
N Drawer Frt/Bk (2)	7 ⁷ / ₈ x 22 ¹ / ₈ - 1/2 Ply.	
O Drawer Sides (2)	7 ⁷ / ₈ x 13 ¹ / ₄ - 1/2 Ply.	
P Drawer Bottom (1)	12 ³ / ₄ x 22 ³ / ₈ - 1/4 Hdbd.	
(2) 6 ¹ / ₂ " Utility Pulls		
(12) 1/4"-20 Threaded Inserts		
(2) 1 ¹ / ₂ " Continuous Hinges, cut to 14" (w/ Screws)		
(2) 3/8"-dia. Rare-Earth Magnets w/Cups, Washers, and Screws		

Source Information:
Knobs from McMaster.com, #1373T57, #1373T58

Magnet hardware from LeeValley.com, #99K3203 (3/8" magnet), #99K3252 (3/8" cup), #99K3262 (3/8" washer), #99K3103 (1/2" magnet), #99K3253 (1/2" cup), and #99K3263 (1/2" washer)

Note: Cutting diagram found on page 6

Adding the Support Bars & Drawer

One of the best features of the workcenter is the pair of support bars (photos at right). They're sized to work in tandem with the clamping bars on your dovetail jig to help support the workpieces. And they include adjustable stops that help keep the workpieces aligned and square in the jig. There is one on the top behind the dovetail jig. And there's another on the front, below the jig. To help you size the support bars to your jig, now would be a good time to go ahead and mount the jig to the case.

MOUNTING THE JIG. The easiest way to mount the jig is to center it along the top. Your jig may have a clamping bed that hangs down the front. Set this tight against the front face. Then all you need to do is mark the mounting hole locations for your jig and drill holes for threaded inserts. Before moving on to making the support bars, fasten the jig in place with round studded knobs (Figure 4).

SUPPORT BARS. For the support bars to work properly, they should be



Top Stop Bar. Besides accurate positioning, the stop bar helps support the workpiece.

flush with the front and top clamping beds of the jig. So the height of the support bars will depend on your jig's dimensions.

There's an important thing to note here. Some dovetail jigs don't have a clamping surface that will extend past the front of the case as mine does (Figure 4). If that's the case with your jig, you can eliminate the front support bar.

LAMINATED BLANK. To make the support bars, you'll start by gluing up three layers of $\frac{1}{2}$ " plywood, as shown in Figure 4c. I made my

▲ **Adjustable Stops.** These adjustable stops help keep longer workpieces square in the jig.

blank large enough to complete both the top and front stop bars.

The next thing to do is to size them to fit your jig. I used a scrap piece in the jig and cut the support bars so they fit snugly between the workpiece and the top of the workcenter. Finally, I cut two "ears" at the ends of the top bar that are used for attaching it to the jig.

ATTACH THE BARS. Like the dovetail jig, the bars are attached to the workcenter with studded knobs and threaded inserts. Once you get the bars locked down tight, the box

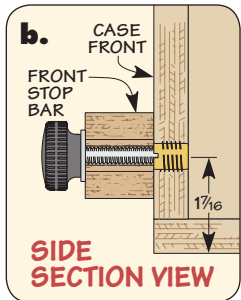
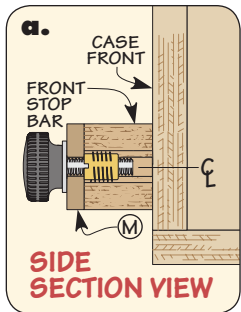

4

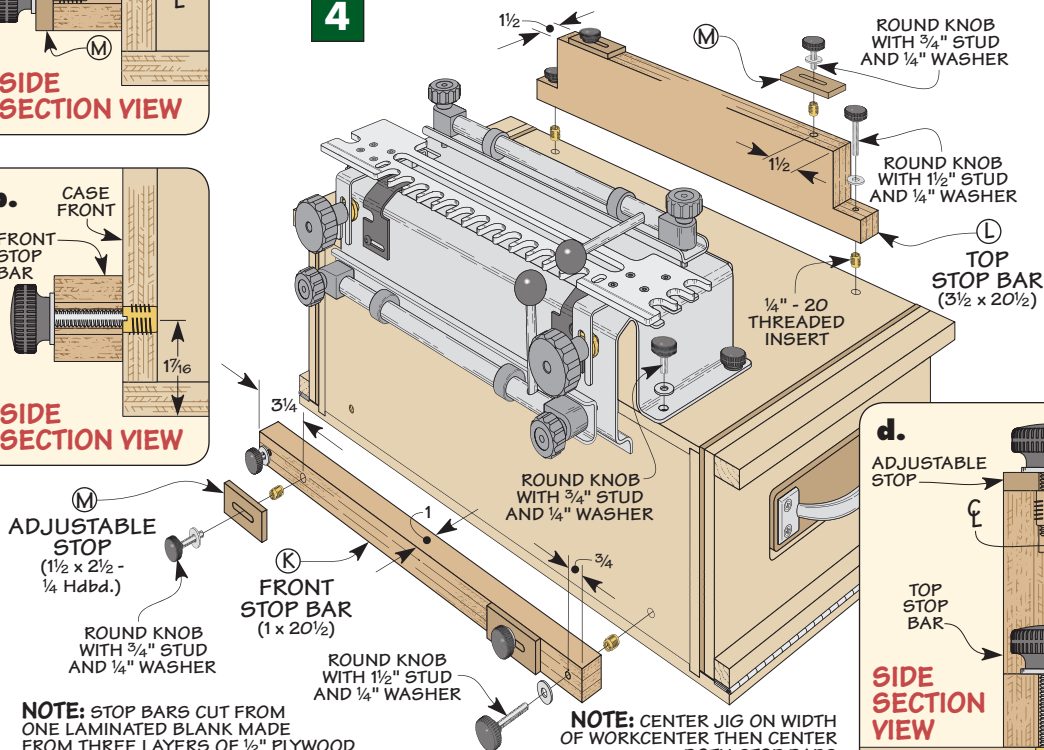

NOTE: STOP BARS CUT FROM ONE LAMINATED BLANK MADE FROM THREE LAYERS OF $\frac{1}{2}$ " PLYWOOD

NOTE: CENTER JIG ON WIDTH OF WORKCENTER THEN CENTER BOTH STOP BARS

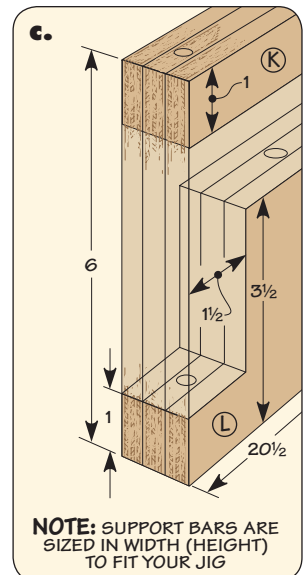
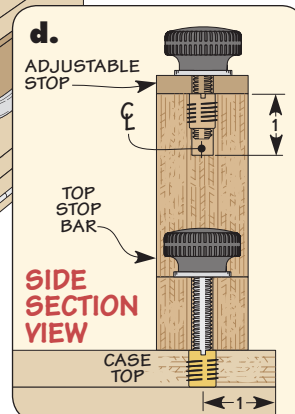

NOTE: SUPPORT BARS ARE SIZED IN WIDTH (HEIGHT) TO FIT YOUR JIG

at the bottom of this page will show you how to locate and attach the adjustable stops for your jig. Then you can move on to building the drawer.

DRAWER

The storage drawer slips into the back of the case. And it's large enough to store the jig, extra templates, support bars, and knobs. (Refer to the photo on page 2.)

DRAWER BOX. Before I cut the drawer sides to length, I measured the inside depth of the workcenter. The goal is to have the face of the drawer flush with the outside edge of the case. I subtracted the thickness of a rare-earth magnet, cup, and washer since these will be fastened to the back of the drawer and case. (They will help hold the drawer closed.)

The drawer front and back are joined to the sides with tongue and dado joints reinforced with screws. After you cut the front and back pieces to size, cut a groove on all four pieces to hold the bottom of the drawer in place.

NOTCHES. Before you glue everything together, you'll want to make the handle notches on the drawer front. And you'll need to form a long notch on the back.

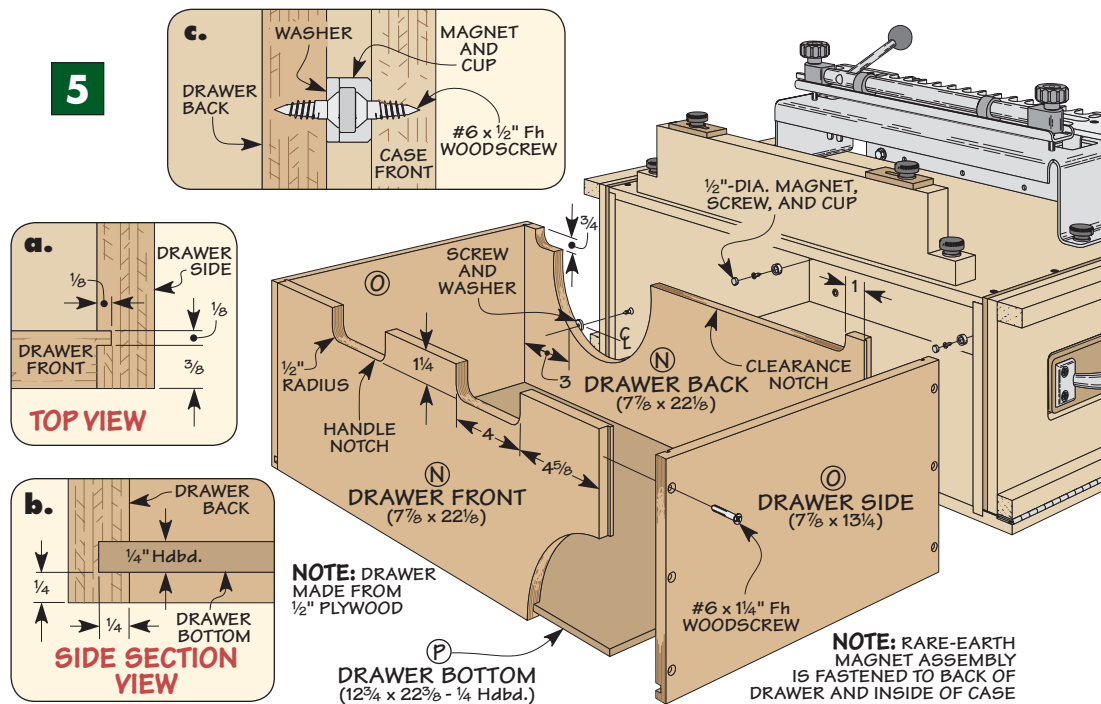

This provides clearance for the studded knobs that extend into the case when you attach the jig.

MAGNET CATCHES. The last thing to do is attach the two rare-earth magnets that hold the drawer in the case. I installed the washers on the drawer back, then used them to locate the magnets inside the case, as you can see in Figure 5c.

A word of caution here. These magnets are pretty strong, but you

should still be careful when the drawer is fully loaded and you're moving the workcenter around.

FINAL WRAP-UP. Now you're almost ready to go. Just clamp the dovetail jig workcenter securely to your bench, and get everything adjusted. Then you're ready to start routing great-looking dovetails. It won't take long for you to appreciate how convenient and useful this workcenter is.

LOCATING THE ADJUSTABLE STOPS

Locating the adjustable stops on the support bars is a simple process. The first thing to do is find the range, or limits, of your dovetail jig's built-in stops. The drawing shows how I used workpieces clamped in the jig to do this. (You can also use a square.)

Once I had the range of my jig's adjustable stops marked on the support bars, I measured $\frac{3}{4}$ " outside that range. This is where you can drill and install the threaded inserts. Then I cut a slot in the hardboard stop that was $\frac{1}{2}$ " longer than that range limit I marked on the support bars.

Now, with the adjustable stops installed, it's just a matter of aligning them with those on your jig.

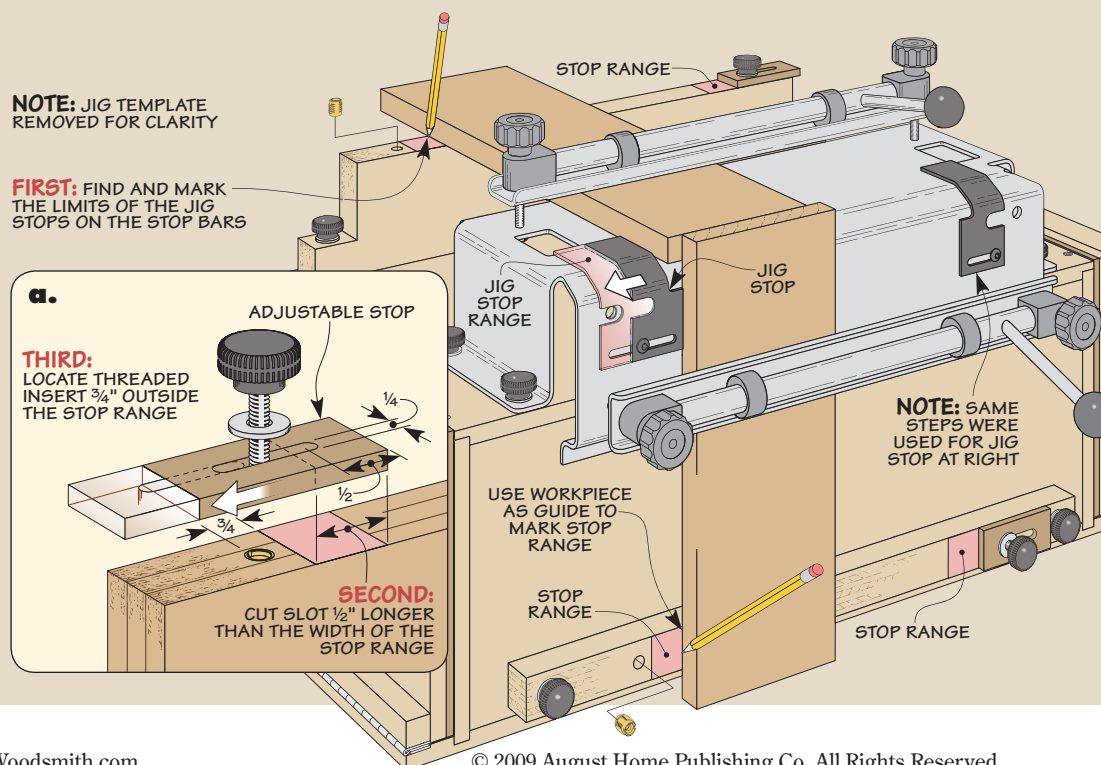

CUTTING DIAGRAM

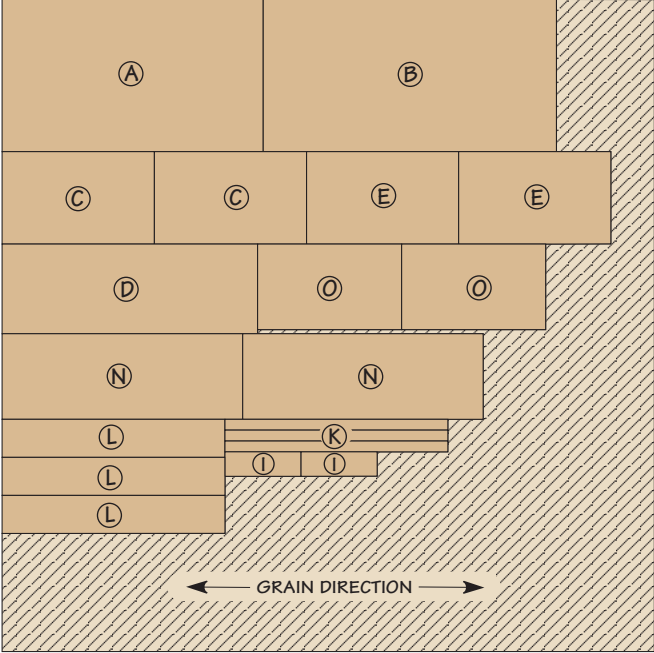

60" x 60" - 1/2" BALTIC BIRCH PLYWOOD

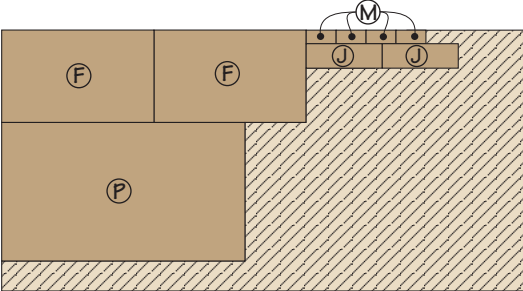

24" x 48" - 1/4" HARDBOARD

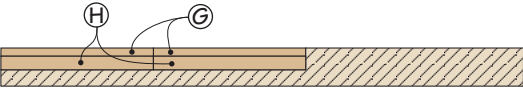

3/4" x 3 1/2" - 48" HARDWOOD