



THANK YOU!

You have successfully downloaded your *Woodsmith* project plan.

▶ [Go to Page 1](#)

Get More from Your Band Saw...at PlansNOW.com



Build this Elegant Hall Table Using Your Band Saw

We'll show you how to cut and shape table legs on a band saw—a technique you can use on any woodworking project.

▶ [Download Today at PlansNOW.com...\\$9.95](#)



Build a Table and Fence for Your Band Saw

The table creates a large work surface that's about three times the size of the cast iron table your band saw came with.

▶ [Download Today at PlansNOW.com...\\$5.95](#)

You Can Build It...at PlansNOW.com



Workbenches

Good woodworking starts with a solid workbench.



Shop Jigs & Techniques

Get the most from your tools with easy-to-build shop jigs.



Cabinets & Shelves

Build stunning furniture that's both functional and beautiful.

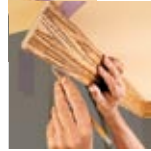

Home Improvement

Save hundreds of dollars in remodeling when you DIY.



Woodsmith **PLANS**

BAND SAW TUNE-UP



BAND SAW TUNE-UP

Slice thin veneers, make intricate scroll cuts, even cut accurate joints — with just one tool. You can turn your band saw into an all-purpose, precision workhorse. All you need are some simple tools and a few minutes of time.

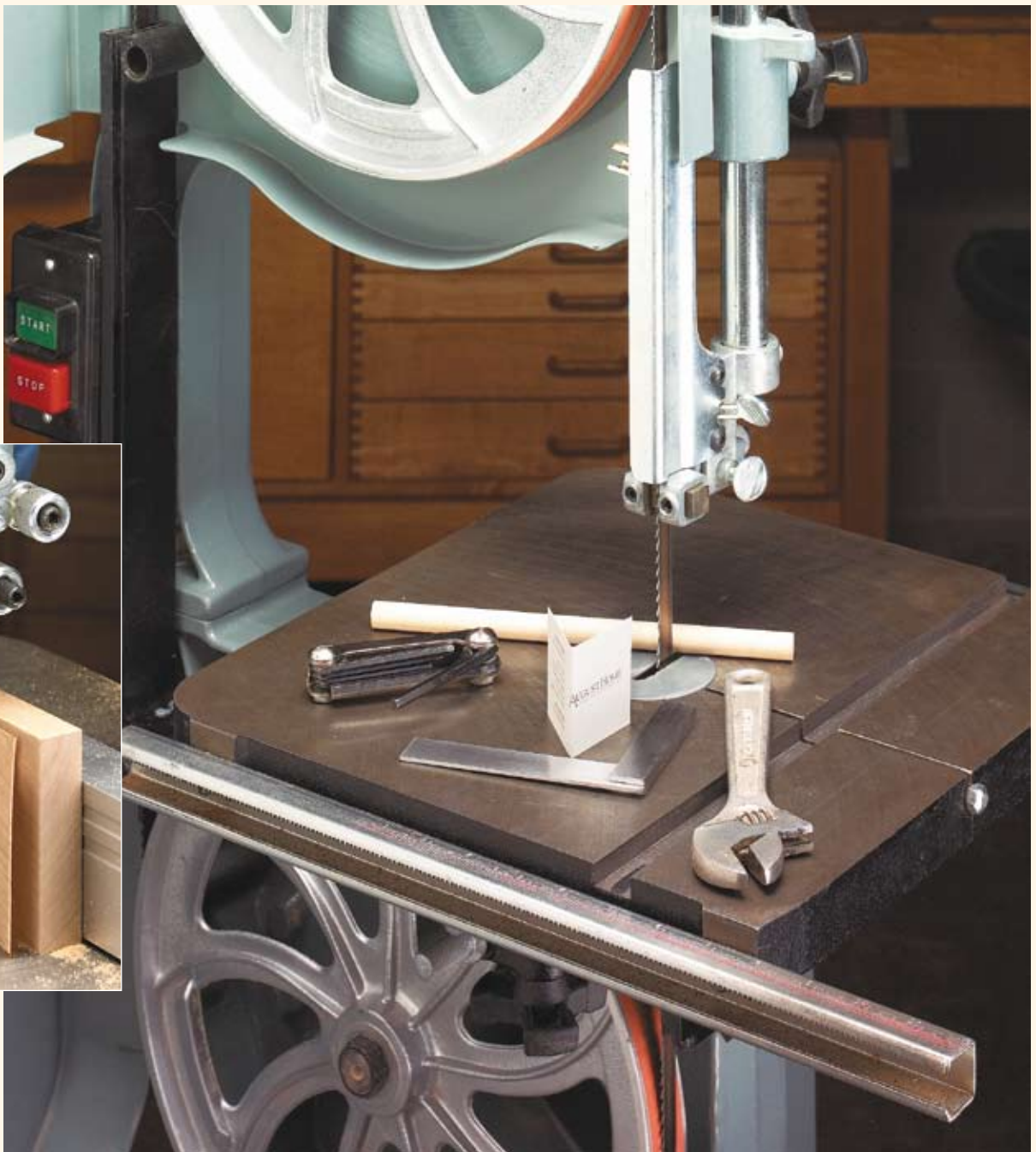

▲ **Accurate Cuts.**
You can make precise cuts like this on your band saw. We'll show you how.

The first few adjustments only need to be made occasionally, but they're still very important. So, how do you know when to do it? Personally, I like to give my saw a good once over every time I make a blade change or every few months, depending on how much I've been using it.

SAFETY FIRST. It goes without saying that before you check or adjust anything on the band saw, always unplug it. Never rely on the "on/off" switch for protection. Now is also a good time for you to take the blade off the wheels.

LOOK IT OVER. With the covers open, it's a good idea to take a few minutes to look for any cracks in the frame, loose bolts, or other structural problems. Before moving on you might also want to clean out any sawdust build-up. This can interfere with the function of the blade and wheels of the saw.

TIRES AND WHEELS

Once the blade is off, the next thing to do is to clean the tires. You can easily do this by rotating the wheels and holding an old toothbrush against the tire to clean off any accumulated sawdust or debris. This gives you the chance to inspect the tires for cracks and wear. Worn tires make it difficult to keep the blade tracking on the wheels (see photo in margin at right).

If your tire is bad, don't hesitate to replace it. Whenever you replace one of the tires, it's best to replace the other one at the same time.

WHEEL BALANCE. It's easy to overlook the importance of having the wheels balanced and properly aligned. Out of balance wheels will cause the blade to wander. This will make it difficult for you to make consistently straight and accurate cuts.

There's a simple way to determine the balance of the wheels. Just mark

a spot on one of the wheels and then give it a good spin. Note the position that it stops and then spin it several more times. If the mark on the wheel continues to stop in the same place, your wheel is out of balance.

Rebalancing your wheels can be kind of tricky. Refer to your manufacturer's recommendation for rebalancing the wheels or take it to someone who can do this for you. If the wheel is significantly out of balance, you may want to consider replacing it with a new one.

WHEEL ALIGNMENT. The other thing you'll want to check is the alignment of one wheel in relation to the other. Before you do this, you'll need to put the blade back on and tension it properly.

You'll find that blade tension affects the wheel alignment and making a change to one thing makes a change to all the others.

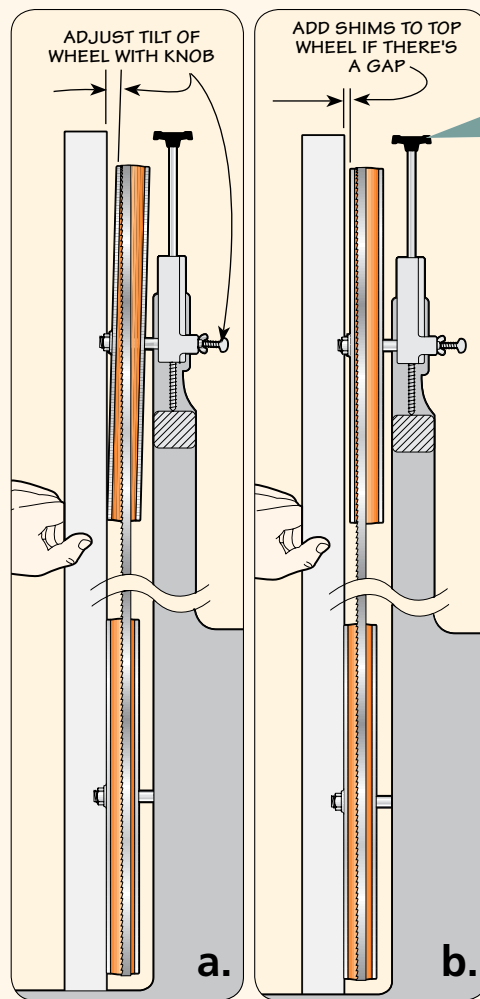

▲ **Wheel Alignment.** Adjust the wheels either by tilting the top wheel (detail 'a') or by repositioning one of the wheels (detail 'b').



◀ **Vertical Wheel Alignment.** A long straightedge placed across the top and bottom wheel makes it easy to check the alignment of the wheels.



▲ **Tire Wear.** The ridge on this tire was caused by setting the blade tension too high.

Checking the alignment of the wheels is easy, but you may need to remove the table. Place a straightedge across the top and bottom of both wheels (photo above). If the straightedge touches both edges at the same time, the wheels are in proper alignment (co-planar).

You won't always find perfect alignment of the wheels when you check them. But you'll want to see the wheel rims within about $\frac{1}{16}$ " of the straightedge.

If the straightedge doesn't touch both edges, tilt the top wheel by adjusting the tracking knob until the straightedge just barely touches the lower wheel (see detail 'a').

And if the wheels are still not aligned, you may need to use washers or another type of shim to reposition one of the wheels (see detail 'b').

Blade and Guides

Once the tires and wheels are in good shape, you can move on to a few other adjustments that you'll need to make more often.

BLADE TENSION AND TRACKING

I start by taking a look at the blade tension and tracking. Tension refers to the tightness of the blade on the saw. Tracking is the path the blade takes on the wheels. These two settings can be adjusted by a pair of knobs on the back of the saw, as shown in the photo below.

BLADE TENSION. To keep the band saw cutting straight and true, the

flexible blade needs to be pulled tight. The tension knob does this by moving the wheels farther apart. Different width blades require different tensions. When there's not enough tension on the blade, it can wander and leave a "cupped" cut in the workpiece.

You may have heard that increasing the tension is an easy way to solve your cutting problems. But doing this puts a lot of stress on the frame of the saw and will shorten the life of the wheel bearings and blades.

Most saws have a tension gauge as a reference for tensioning different blade sizes (see photo below). I've found that it's not very accurate, but it will get you close.

To get the tension set correctly, I do a simple push test.

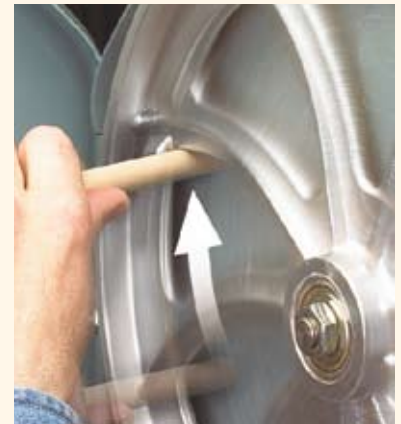

▲ **Safety Tip.** To prevent catching your fingers in the wheel, use a short dowel to spin the wheel by hand with the saw unplugged.

First, raise the blade guide to its highest position. Now push on the side of the blade. Narrow blades (less than 1/2") will deflect about 3/8" when properly tensioned. The wider blades should deflect no more than 1/4".

BLADE TRACKING. If your wheels are properly aligned and balanced and you have the right tension on the blade, getting the blade to track properly should only take a minor adjustment. What you're looking for is to have the blade run near the center of the tire.

To check the tracking, unplug the saw and open the door. Then with a short piece of dowel, rotate the upper wheel several times, as illustrated in the photo above. If needed, turn the tracking knob or screw until the blade stays in the middle of the wheel as it is turned.

Remember to take it slow when adjusting the tracking. If you turn the screw too much, the blade can run off the edge of the wheel and you'll need to start over.

GUIDES AND THRUST BEARINGS

With the tension and tracking set, there are just a few steps left before you're ready to go.

The next things to check are the two guide assemblies. One is located above the table and one below the table, as illustrated in Figure 1 on the following page.

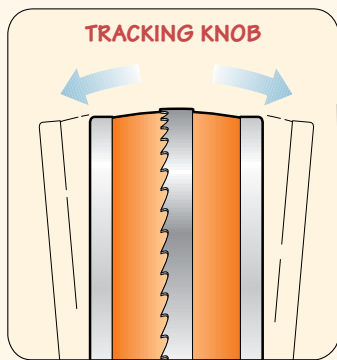
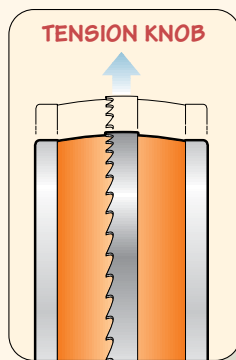

UPPER GUIDE ASSEMBLY CONTROLS BLADE MOVEMENT, SEE FIGURE 1 ON PAGE 4.

BLADE TENSION GAUGE SHOWS PROPER TENSION BASED ON BLADE WIDTH

TABLE ADJUSTMENT KNOB

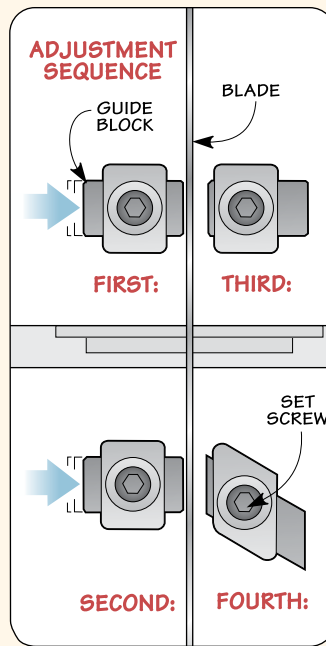
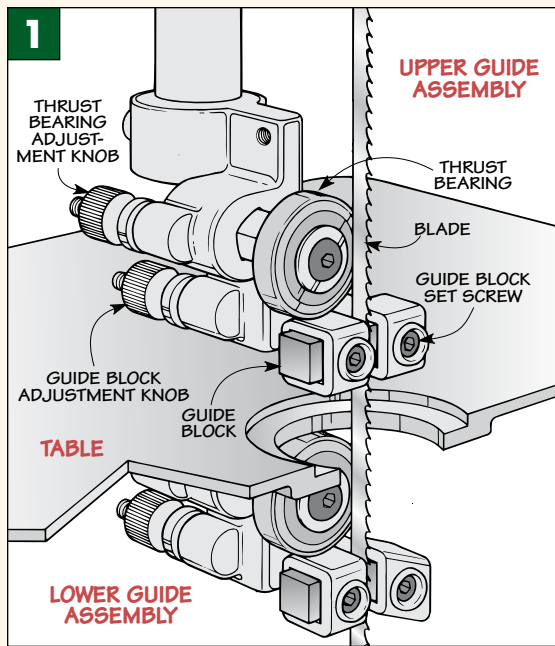

◀ **Guide Blocks.** A business card helps position the guide blocks. Adjust the blocks on one side and then the other (sequence at left).



◀ **Thrust Bearing.** Use a business card folded in half to set the position of the thrust bearing.

Each guide assembly consists of a pair of guide blocks and a thrust bearing located behind the blade. The purpose of the guides and bearings is to keep the flexible blade running straight and true. If they're not set right, the blade can end up twisting and get pushed off the wheel or even break.

You'll need to make two different adjustments — one for the guide assembly and the second to each of the guide blocks.

GUIDE ASSEMBLY. Before adjusting the guide assembly, it's a good idea to loosen the guide blocks and back them away from the blade. Don't take them all the way out because you will need them as a reference for the next adjustment.

Next, loosen the thumbscrew and slowly move the guide blocks either forward or backward on the blade, as shown in Figure 2.

The guide blocks should be positioned just behind the gullets

on the blade, as illustrated in Figure 2a. After setting the upper guide assembly, set the guide assembly below the table.

GUIDE BLOCKS. With the guide assemblies set, you can adjust the guide blocks. As I mentioned before, they straddle the blade and keep it on track. They should be positioned close to, but not touching, the blade.

I use a business card to set the spacing, as shown in the upper right photo. The drawing above shows the sequence for setting the blocks. Here I set the blocks on one side of the blade then the other to prevent the blade from being misaligned.

Just place the card between the blade and the guide block, and move the guide block until it rests snug against the card. Then just tighten the adjustment screw.

Once all four adjustments have been made, you'll want to turn the wheels (by hand) a couple

of times to be sure that there is adequate clearance for the blade.

THRUST BEARINGS. There's one more part to be adjusted on the guide assemblies — the thrust bearing. It supports the blade from the back when cutting. If the thrust bearing is not supporting the back, the blade won't give you square cuts and may even get pushed off the wheels.

You can use your business card again. This time, fold it in half and place it between the back of the blade and the thrust bearing, as shown in the lower photo above. Position the thrust bearing against the card and tighten the thumbscrew to hold the bearing in place.

SQUARE UP THE TABLE

Once the guides and thrust bearings are set, you can make the final adjustment. That is to check that the table is square to the blade. If it's not, your cuts won't be perpendicular.

Just raise the upper guide assembly and place a small square on the table against the blade, as you can see in the photo at right. If the table isn't square, loosen the table adjustment knob and tilt the table into position. Then retighten the knob.

It's all too easy to put off these simple adjustments. But it only takes few minutes to run through them. With your saw tuned, you'll turn to it more often and get better results in your woodworking projects.



▲ **Square the Table to the Blade.** Using a small square, make sure the blade is 90° to the table.

