



THANK YOU!

You have successfully downloaded your *Woodsmith* project plan.

▶ [Go to Page 1](#)

Get More from Your Table Saw...at PlansNOW.com



Build our 10 BEST Table Saw Jigs!

What really makes a table saw so versatile are the jigs and accessories that improve your saw's overall performance.

▶ [Download Today at PlansNOW.com...\\$4.95](#)

You Can Build It...at PlansNOW.com



Workbenches

Good woodworking starts with a solid workbench.



Shop Jigs & Techniques

Get the most from your tools with easy-to-build shop jigs.



Cabinets & Shelves

Build stunning furniture that's both functional and beautiful.



Home Improvement

Save hundreds of dollars in remodeling when you DIY.



Woodsmith **PLANS**

SHAKER HALL TABLE



SHAKER HALL TABLE

The simple lines of this table hide the woodworking techniques, like mortise and tenon joinery, that make it so rewarding to build.



This hall table is a very traditional Shaker project. The square tapered legs—a hallmark of Shaker design—lead up to the straight, uncluttered lines of the table.

The legs are tapered on all four sides. There are a couple of ways you can do this. I used a shop-made jig on the table saw. You can find out how to build and use this jig on page 9. Another method uses the jointer. For more information on this technique, see page 11.

JOINERY. The legs are joined to the front and side aprons with traditional mortise and tenon joints. If you haven't tried this type of joinery, it's not as

difficult as it sounds. It can all be done on a router table (for the mortises) and a table saw (for the tenons).

DRAWERS. For the drawers, I used two variations of a locked rabbit joint. As its name implies, it locks the sides of the drawer to the front and back. This makes a strong joint so the drawers can take years of use. It is also cut entirely on the table saw.

FINISH. I built this table out of cherry. One of the keys to success when finishing cherry is patience. It takes time for the wood to reach the rich red color that cherry is known for.

When it comes from the lumberyard, cherry is usually a light pink

or salmon color. There's no need to stain it to get the dark color. As soon as the finish is applied, the wood will darken somewhat. With time (approximately six months) and continued exposure to sunlight, it will turn a rich, dark red. It's well worth the wait.

LAMP TABLE. In the Designer's Notebook on page 8, we show how you can make a lamp table companion piece (or two) by simply shortening the length of the table. And since the construction is so similar, it's easy to cut the parts for the lamp table while you're set up to cut pieces for the hall table.

Construction Details

Overall Dimensions:
42" x 14½" x 29"

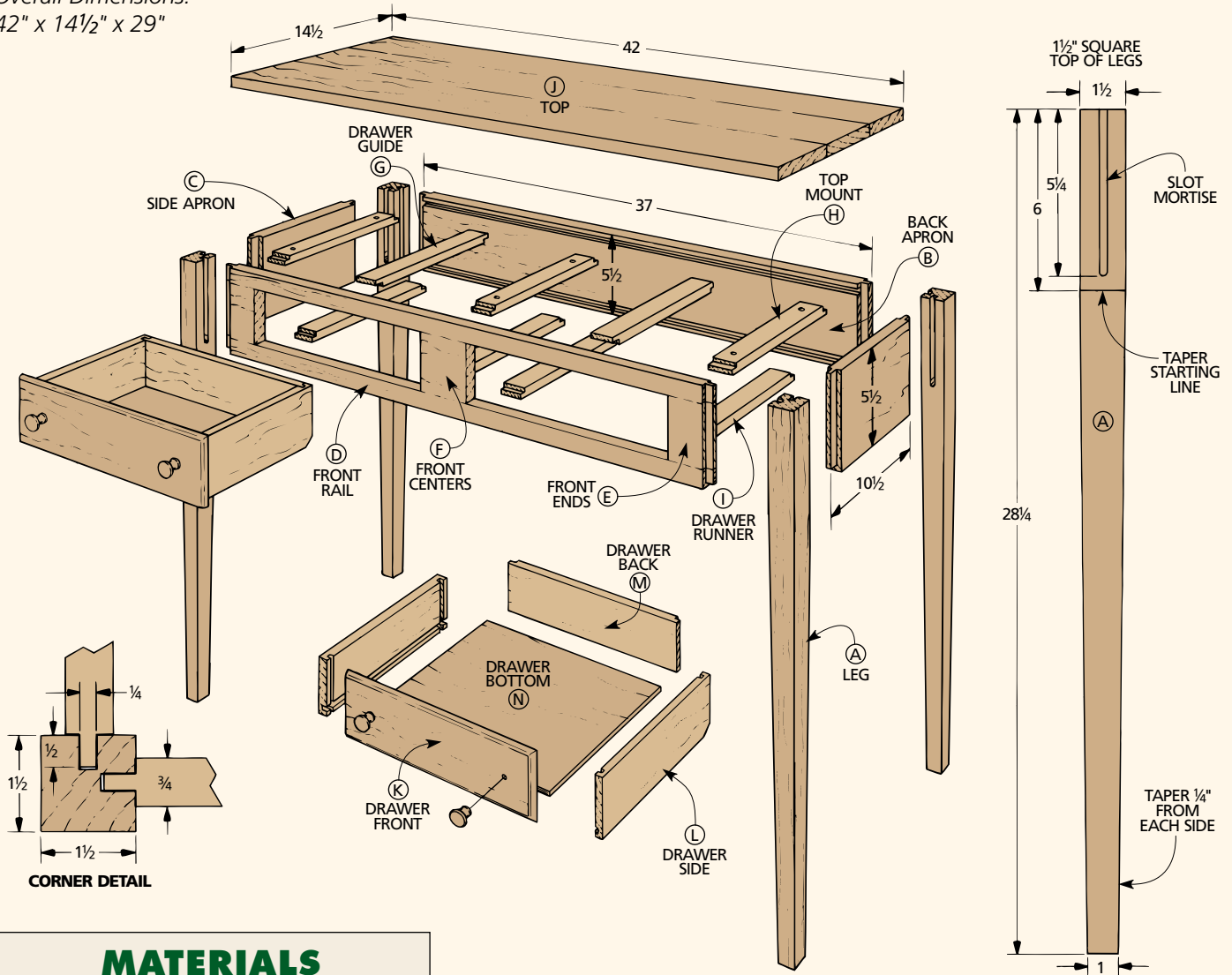

MATERIALS

A Legs (4)	1½ x 1½ - 28¼
B Back Apron (1)	¾ x 5½ - 37
C Side Aprons (2)	¾ x 5½ - 10½
D Front Rails (2)	¾ x 1 - 37
E Front Ends (2)	¾ x 3½ - 2¾
F Front Center (1)	¾ x 3½ - 3½
G Drawer Guides (2)	¾ x 1½ - 10¾
H Top Mounts (3)	¾ x 1½ - 10¾
I Drawer Runners (4)	¾ x 1½ - 10¾
J Top (1)	¾ x 14½ - 42
K Fronts (2)	¾ x 4¾ - 14¼
L Sides (4)	½ x 3¾ - 10¾
M Backs (2)	½ x 2¼ - 13¾
N Bottoms (2)	¼ ply. - 10½ x 13¾

- (2) #6 x ¾" Rh woodscrews
- (6) #8 x 1¼" Rh woodscrews
- (6) ¾" flat washers
- (18) ¾" brads
- (4) ⅝" brads
- (4) 1"-dia. cherry knobs w/ screws

CUTTING DIAGRAM

1½ x 3¼ - 60 (3.2 Bd. Ft.)



¾ x 5¾ - 60 (2.5 Bd. Ft.)



¾ x 6½ - 84 (3.9 Bd. Ft.)



¾ x 6 - 96 (4 Bd. Ft.)

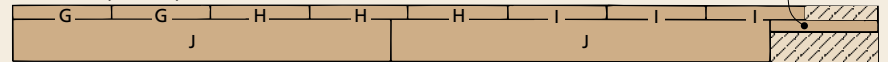

½ x 3¼ - 84 (2.1 Sq. Ft.)

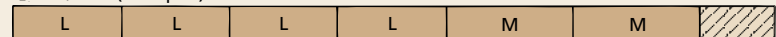

NOTE: ALSO NEED ONE SHEET OF ¼" x 24" x 48" PLYWOOD FOR DRAWER BOTTOMS.

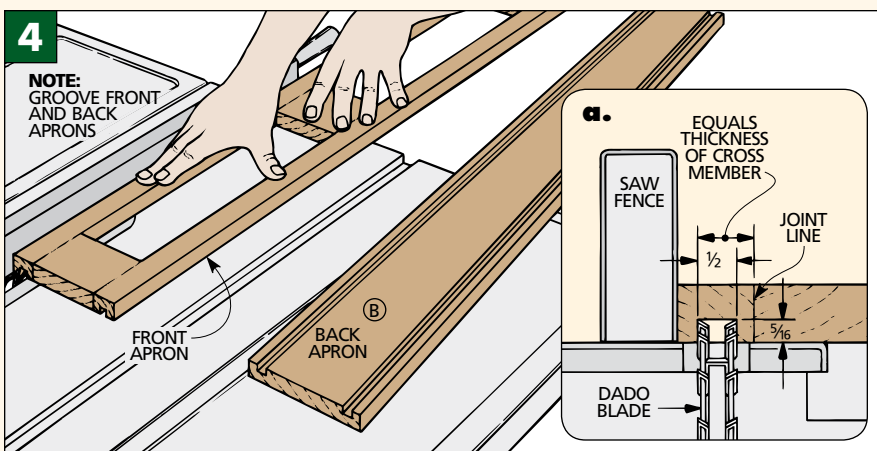
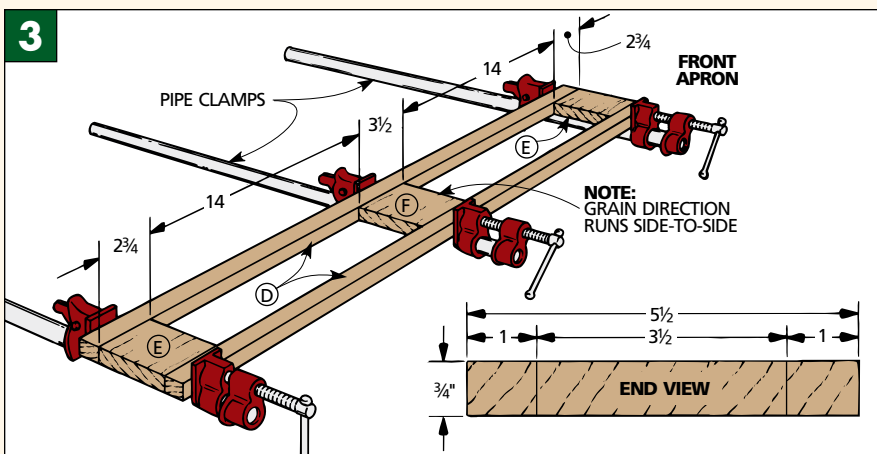
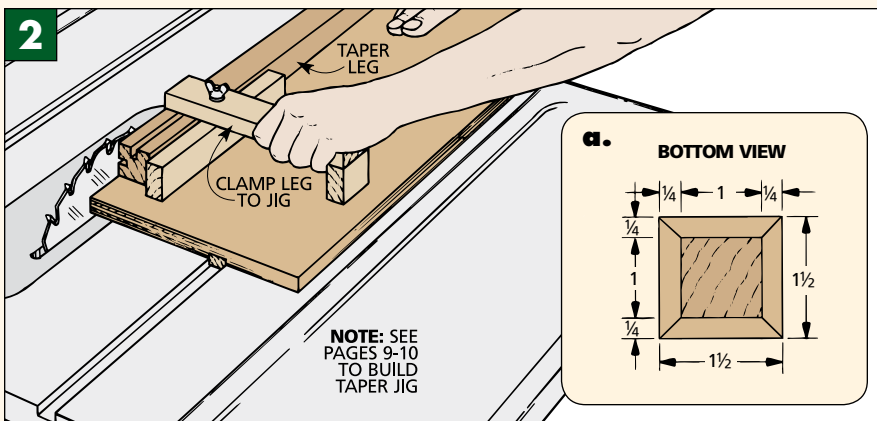
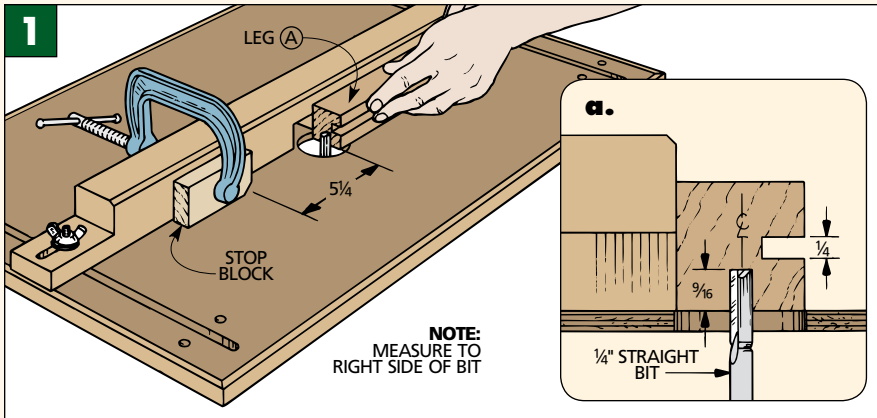

Legs

The shaker hall table project starts by making the tapered legs and cutting the mortises in each of them. To do this, begin by cutting four leg blanks (A) to 1 1/2" square by 28 1/4" long (refer to the construction details on page 2).

MORTISES. After cutting the legs to size, mark two adjacent sides where the mortises will be cut. (It's best to cut them before tapering the legs.) The mortises are easy to cut on a router table with a 1/4" straight bit. To set up the router table for, start by raising the bit to 9/16" (Fig. 1a). Then move the fence until the bit is centered on the thickness of the leg.

The length of the mortise is set by clamping a stop block to the fence 5 1/4" from the right side of the bit (Fig. 1). Then cut the mortises on two adjacent sides.

TAPERS. After the mortises are routed, the next step is to taper all four sides of each leg. To cut the tapers, I used a sliding platform jig on the table saw (see Fig. 2 and the jig article on page 9). Or taper the legs using a jointer, as shown in the article on page 11.

Whatever method you use, the point is to cut a taper on each side of the leg that starts 6" from the top end and tapers down so the bottom end is 1" square. This means cutting 1/4" off each side (Fig. 2a).

Aprons

After the tapers are cut, the next step is to cut the front apron assembly. This consists of five pieces glued together to form two drawer openings (Fig. 3).

FRONT APRON. To make the front apron, start by ripping the top and bottom rails (D) 1" wide by 37" long. To get a good grain match for the apron, make sure to cut the pieces as shown in the cutting diagram on page 2.

To make the three dividers for this front assembly, rip a blank 3 1/2" wide. Then cut off two end dividers (E) 2 3/4" long, and a front center (F) 3 1/2" long. (This ensures that the grain runs the same direction as the rails.)

ASSEMBLE FRONT APRON. After cutting all five pieces for the front apron, glue and clamp the dividers between the top and bottom rails (Fig. 3). Make sure the center divider (F) is centered on the length, and the end dividers (E) are flush with the ends.

BACK AND SIDE APRONS. Next, cut the back apron (B) and side aprons (C). Start by ripping the stock for these pieces to a width of 5½". Then cut the three pieces to finished lengths of 10½" for the sides, and 37" for the back. (The back apron should be exactly as wide and as long as the front assembly.)

GROOVES. To support and guide the drawers, cross members (G, H, I) fit into ½"-wide grooves cut along the inside faces of the front and back aprons (refer to Fig. 11 on page 5).

The positions of these grooves are critical. They have to be cut so that when the drawer runners (J) are mounted, they're flush with the top edge of the front apron's bottom rail (refer to Fig. 11c on page 5).

To set up the saw for this position, adjust the fence so the distance from the inside edge of the rail (the joint line shown

in Fig. 4a on page 3) to the inside edge of the dado blade equals the thickness of the stock for the drawer runner. (This means you need to measure from the joint line, not the rip fence.) Then cut the grooves in the front and back aprons (Fig. 4).

TENONS. Now tenons can be cut on the ends of the aprons to fit the mortises in the legs. I cut them on the table saw (Fig. 5).

The ½"-long tenon is formed by cutting ½"-wide rabbets on both faces of the apron (see Fig. 5a). Note: The tenon is ¼" less than the depth of the mortise to allow a little glue relief at the bottom of the mortise.

To cut the tenons, I used a ¾"-wide dado blade and moved a plywood auxiliary fence over the blade so only ½" was exposed (see Fig. 5).

Sneak up on the final height of the blade by raising it and making a pass on both

faces of a scrap piece until the tenon fits the mortise. Once set, cut rabbets on both ends of all four aprons to produce tenons centered on the thickness of the stock.

Note: To get a tight fit against the leg, I used a chisel to slightly undercut the shoulders of each tenon. (See the box at the bottom of this page for more on this.)

NOTCH TENONS. So that the top of each apron will sit flush with the top of each leg, the bottom end of each tenon has to be notched (Fig. 7). Since the mortises are rounded on the bottom, I cut the tenon a trifle shorter so I didn't have to square up the bottom of the mortise. This means cutting a ⅜" notch on the bottom of each tenon (Fig. 6).

END PIECES. To make assembly easier, I glued a pair of legs to each side apron to produce two complete end units. But don't glue on the front or back aprons yet.

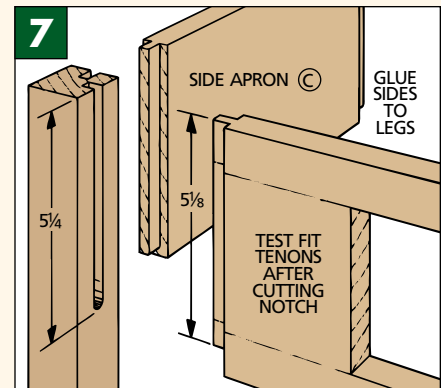
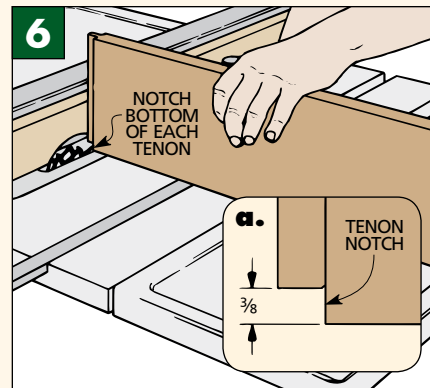
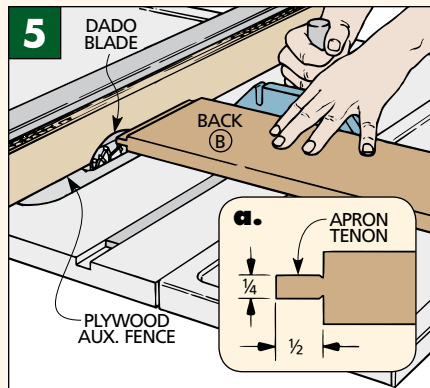

TIGHT FIT SHOULDERS

There's an easy way to make mortise and tenon joints fit together without gaps at the shoulders.

"Undercutting" simply means paring away the end grain ¼" deep along the tenon's shoulders.

The trick is to undercut the area next to the tenon cheek, leaving at

least ¼" untouched along the outside edge of the shoulder. If you cut all the way to the edge, you'll have a gap and a loose joint.

Start by lightly pushing a chisel straight into the corner (Fig. 1). Do this all the way around the tenon. Then to remove the waste, angle

the chisel in toward the cheek of the tenon (Fig. 2).

Also, to prevent the square ends of the tenon from pushing all the glue to the bottom of the mortise, lightly chamfer the ends (Fig. 3). This chamfer can be cut with a chisel or block plane.

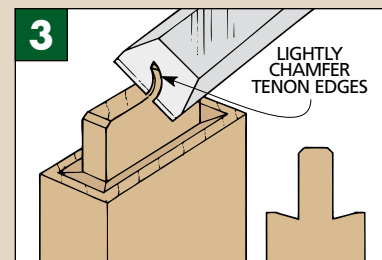
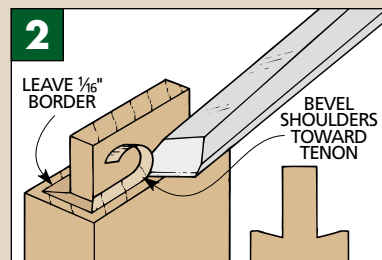
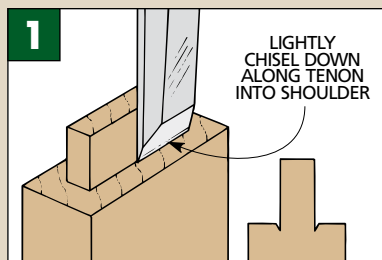

Cross Members, Top, & Assembly

Next, nine cross members are cut to fit between the front and back aprons. Two of these pieces mount above the drawers for drawer guides (G), three are top mounts (H) used to fasten down the table top, and four sit below the drawers as runners (I) (Fig. 10).

CUT TO SIZE. First rip enough stock $1\frac{1}{2}$ " wide to make the nine pieces. To determine their length, dry assemble the table. (It may be easiest to do this with the table upside down.) Measure the distance between the front and back aprons to get the shoulder-to-shoulder length of the cross members. Now add $\frac{1}{2}$ " to this measurement to account for a $\frac{1}{4}$ "-long tenon on each end.

After cutting the pieces to length, form the tenons by cutting a $\frac{1}{4}$ "-wide by $\frac{1}{4}$ "-deep rabbet at each end (Fig. 8).

DRAWER GUIDES. The two drawer guides (G) each have a $\frac{1}{8}$ "-wide groove cut down the center (Fig. 9a). This groove guides a pin that's mounted on the back of the drawer. The pin helps keep the drawer straight as it's pulled out of the carcass.

TOP MOUNT PIECES. To allow the table top to expand and contract, I drilled oversized shank holes ($\frac{3}{8}$ "-dia.) on the three top mounts (H) (Fig. 11b). These holes are centered on the width and drilled $1\frac{1}{4}$ " from each end on all three pieces.

TABLE TOP. Now glue up a blank for the table top (J). Then cut this blank to final size so it will overhang each of the side aprons by $1\frac{7}{8}$ " and the front and back aprons by $1\frac{3}{8}$ ".

ASSEMBLY. After the parts are cut, dry-assemble the table and check it for square. If everything is okay, glue and clamp the front and back aprons to the leg units. Make sure the cross members are in position but not glued in.

There's one important thing to watch as you position the cross members. The rabbets face down on the drawer guides (Fig. 11a), but up on the top mount (Fig. 11b) and drawer runners (Fig. 11c). Use $\frac{3}{4}$ " brads to tack only the top mounts (H) in place. The other cross members will be secured after the drawers are added.

Now center the table top on the aprons and screw (don't glue) it down to the top mounts (Fig. 11b). Use $\frac{3}{16}$ " washers under the screw heads.

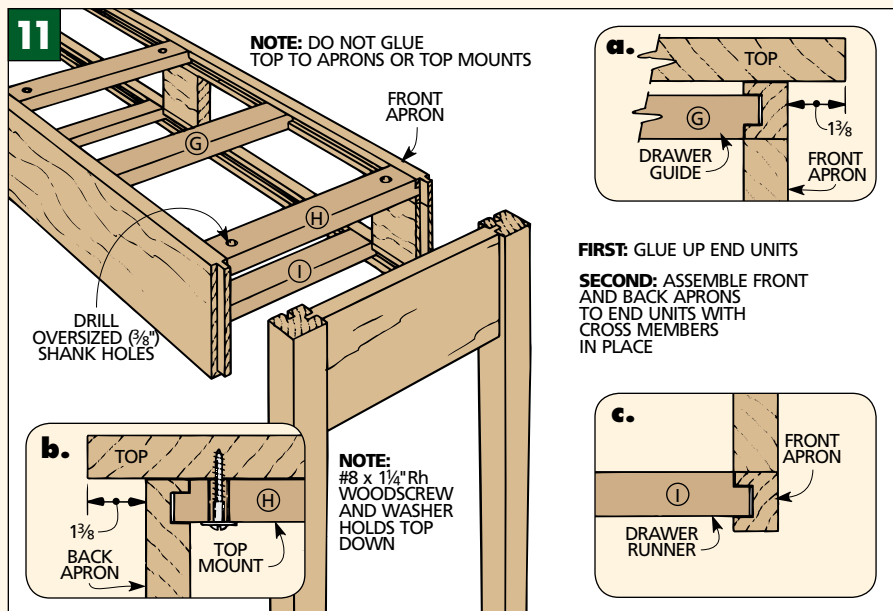
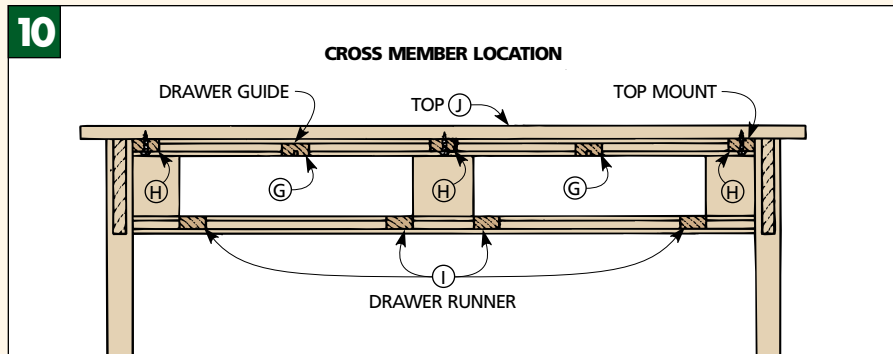
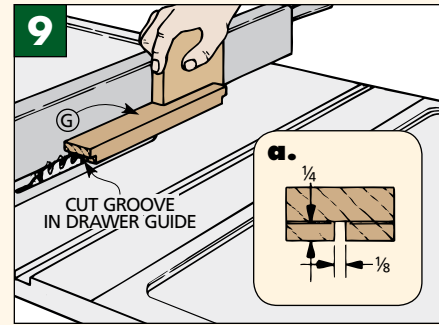
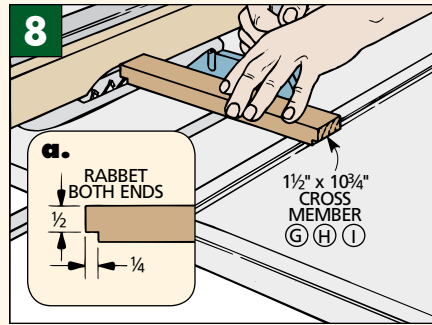

Drawers

Once the table is assembled, all that's left to build are the drawers. The first step in making the drawers is to cut the pieces for each drawer to size.

FRONTS. The drawer fronts (K) are cut from $\frac{3}{4}$ "-thick stock. The length of each front is $1\frac{1}{16}$ " more than the width of the drawer opening. This allows for a $\frac{3}{8}$ " lip on both ends ($\frac{3}{4}$ " total), minus $\frac{1}{16}$ " for clearance. As for the height of the drawer front, measure the height of the opening, add $\frac{3}{4}$ " for the lips, and subtract $\frac{1}{16}$ " for clearance.

SIDES. The drawer sides (L) are cut from $\frac{1}{2}$ "-thick stock. Cut them to width (height) to match the height of the drawer opening, minus $\frac{1}{16}$ " for clearance. As for the length of the sides, measure the depth of the table (from the front of the drawer opening to the back apron). Then subtract about $\frac{1}{4}$ " from this measurement.

BACK. The backs (M) are cut to rough width to match the drawer sides and to rough length to match the drawer front. (The backs are trimmed to final size later.)

LOCKED RABBIT JOINT. After cutting the pieces to size, locked rabbit joints are cut to join the drawer sides to the fronts (Fig. 13). Take a look at the technique on the next page for details on doing this.

A variation of the locked rabbit joint is used to join the drawer back to the sides. First, trim the back to final length. To get this length, measure the distance from end to end of the tongues on the drawer front. Cut the back to equal this measurement.

To cut the locked rabbit joint, first cut rabbets on both ends of the back to leave $\frac{1}{8}$ "-thick tongues (Fig. 13). Then cut a dado in each drawer side to accept this tongue.

DRAWER BOTTOM. Before the drawer can be assembled, a $\frac{1}{4}$ "-deep groove must be cut in the drawer front and sides for the plywood bottom (N). (No groove is needed in the back, since it rests on top of the drawer bottom.)

To locate the grooves, you need to measure from different points for the drawer front and the sides. On the drawer front, the top edge of this groove is located $\frac{1}{2}$ " up from the bottom edge of the lip (Fig. 14). On the drawer sides, it's $\frac{1}{2}$ " from the bottom edge (Fig. 15).

After the grooves are cut, dry-assemble the drawer and cut the drawer bottom to fit. Then trim the back to width so it rests on the plywood bottom.

COMPLETE DRAWERS. All the parts for the drawer are cut, but there are still a few details to take care of before they're done. First, round over the front edges

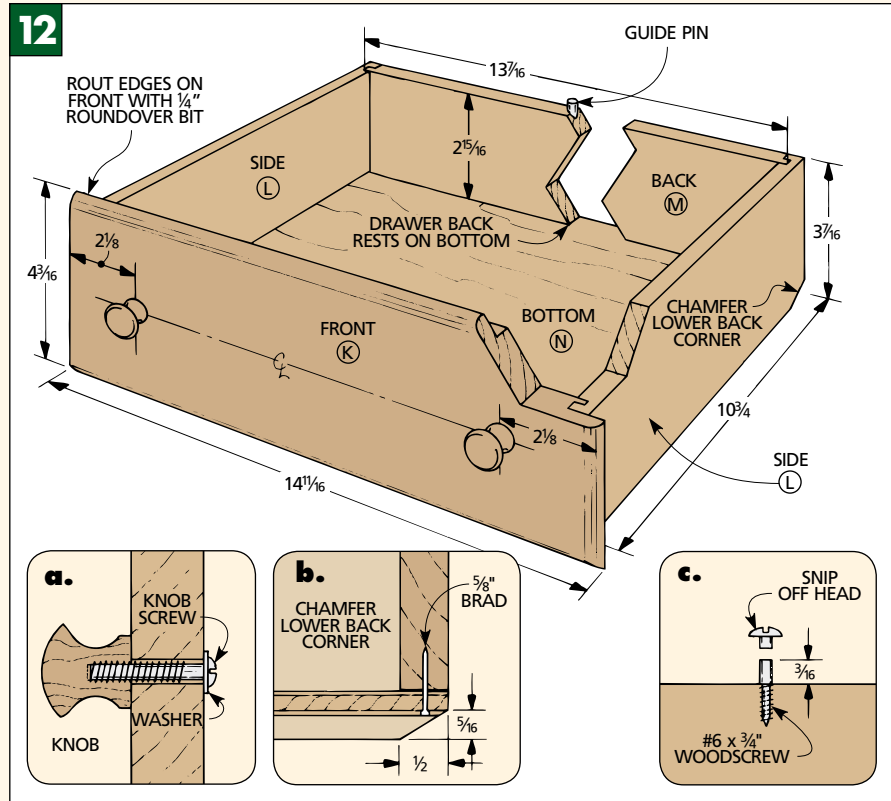

of each drawer front with a $\frac{1}{4}$ " roundover bit (Fig. 12). Now glue each drawer together, making sure it's square.

When the glue was dry, I added a guide pin on the top edge of the back (Fig. 12c). This pin is simply a No. 6 x $\frac{3}{4}$ " brass screw that's screwed part way into the back. Then I cut off the head to leave a guide pin.

One other detail is to cut a slight chamfer on the bottom back edge of

the drawer so it can be tilted into the opening (Figs. 12b and 16).

Finally, for mounting the knobs, I drilled a $\frac{1}{4}$ "-dia. hole $2\frac{1}{8}$ " from each end of the drawer fronts (Fig. 12a).

SECURE CROSS MEMBERS. To finish the table, the drawer guides and runners need to be secured. To do this, remove the top and drawers and drive $\frac{3}{4}$ " brads into the tongues (Fig. 16a).

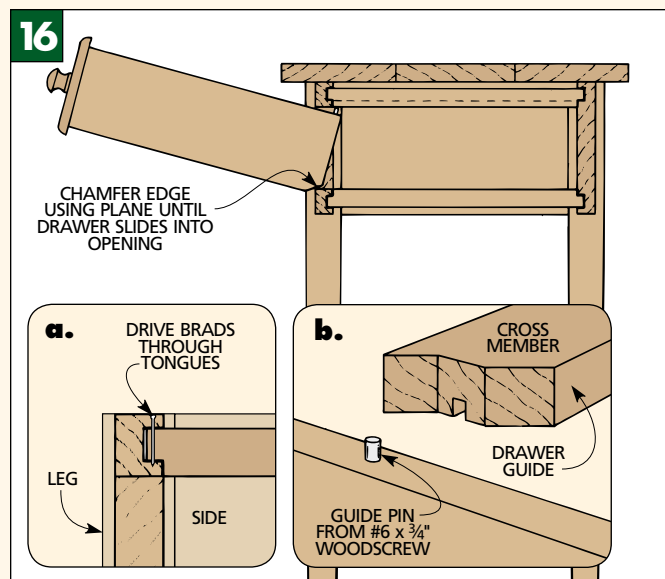
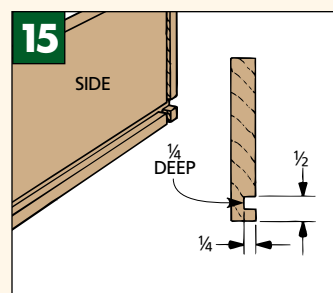
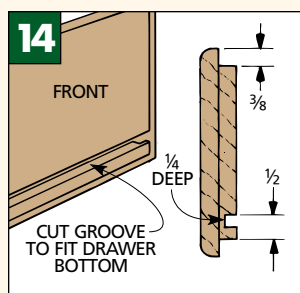
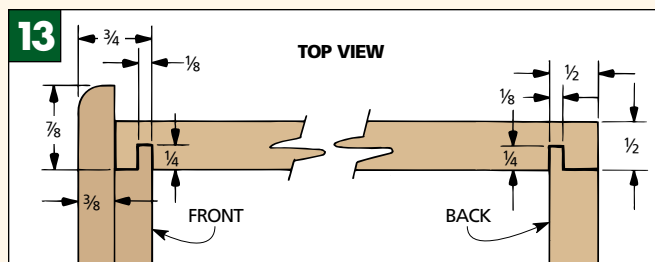

LOCKED RABBET JOINT

There are probably a dozen joints that can be used to join the four corners of a drawer. One of the easiest (and strongest) is a locked rabbet. It doesn't require any fancy equipment. All that's needed is a table saw and a combination blade to cut a flat-bottomed groove.

The version of the joint shown here is for a drawer that has a lipped edge all the way around the drawer front.

RABBETS. The first step is to cut rabbets (lips) on the top and bottom edges of the drawer front (Step 1).

1 First, cut the rabbets on the top and bottom edges of the drawer front. Set the blade $\frac{3}{8}$ " high and adjust the fence so it's $\frac{3}{8}$ " from the outside of the blade. To complete the rabbet, set the fence $\frac{3}{8}$ " from the inside of the blade.

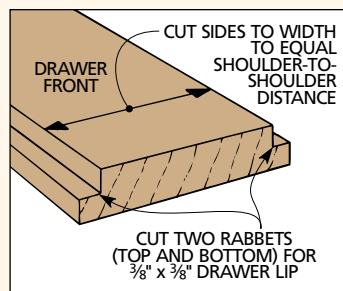

2 To cut the tongue, set the blade height to $\frac{7}{8}$ ". Then move the fence so the inside of the blade is on the shoulder of the rabbet. Make the first cut, and then move the fence away from the blade to leave a tongue the same width as the blade.

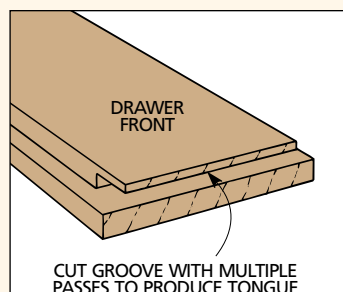

3 To cut the tongue to length, raise the blade so it just clears the tongue. Next, screw or clamp a spacer to the fence for the lip to ride against. (This will help prevent the waste piece from kicking back.) Then adjust the fence to leave a $\frac{1}{4}$ "-long tongue.

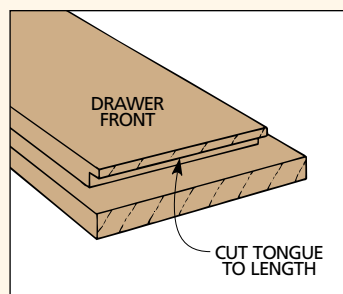

4 Now cut a dado in the drawer side to accept the tongue. Use the drawer front as a gauge. Raise the blade to a height equal to the length of the tongue. Then push the end of the side piece against the fence and cut the dado.

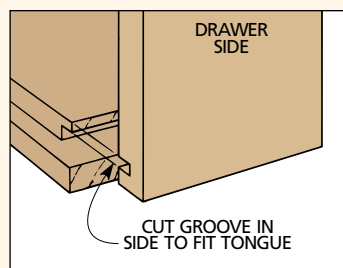

TONGUE. Then a tongue is cut on both ends of the drawer front. To do this, stand the drawer front on end and cut a groove on the end of the stock (Step 2). Then widen it to leave a $\frac{1}{8}$ "-wide tongue. (The $\frac{1}{8}$ " thickness of the tongue is based on the width of the kerf left by the saw blade.)

The tongue is completed by trimming it to a length of $\frac{1}{4}$ " (Step 3).

DADO. To complete the other half of the joint, a $\frac{1}{8}$ "-wide dado is cut on the inside face of the drawer side (Step 4).

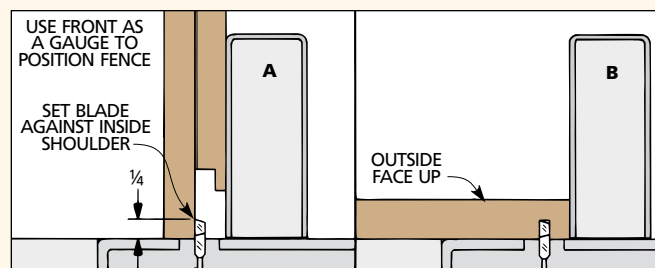
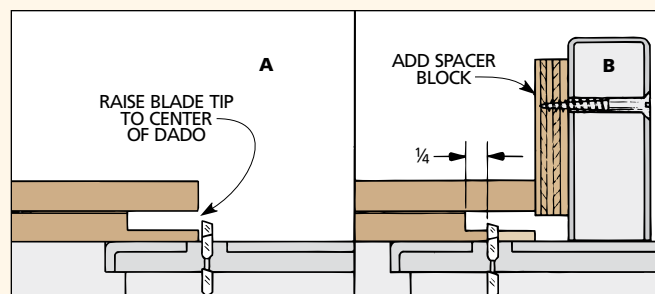
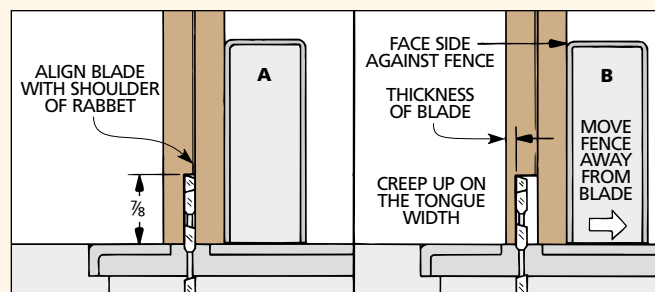
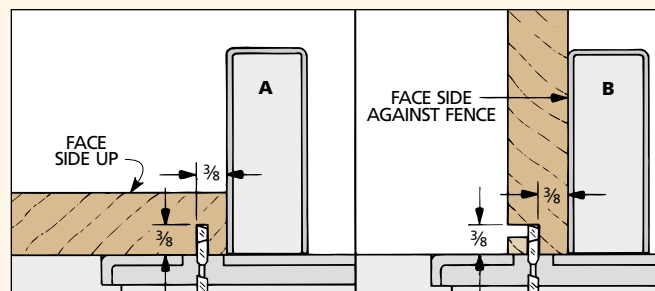

DESIGNER'S NOTEBOOK

By simply shortening the length, the hall table becomes a lamp table with a single drawer. And because construction is so similar, it's easy to build this companion piece at the same time as the hall table.

Construction Notes

- The lamp table is built the same as the hall table. However, some pieces are cut shorter and there are fewer of other pieces (see the materials list below).

- The back apron (B) and front rails (D) are each cut to a finished length of $19\frac{1}{2}$ " (Fig. 1). The front center (F) is not needed in the front apron assembly.

- Cut only one drawer guide (G), two top mounts (H), and two drawer runners (I). Cut rabbets at each end of all these pieces, as was done for the hall table. Also cut the groove for the guide pin in the drawer runner.

- The table top (J) is cut to a finished length of $24\frac{1}{2}$ " (Fig. 1).

- Because the lamp table has only one drawer, you'll need just one drawer front (K), two drawer sides (L), one drawer back (M) and one drawer bottom (N). The drawer uses the locked rabbet joint and is assembled the same as the drawers for the hall table.

- Once the drawer is assembled, mount a single knob on the face of the drawer front (Fig. 1).

- When assembling the table, the top mounts (H) set against the inside edges of the legs (Top View in Fig. 1).

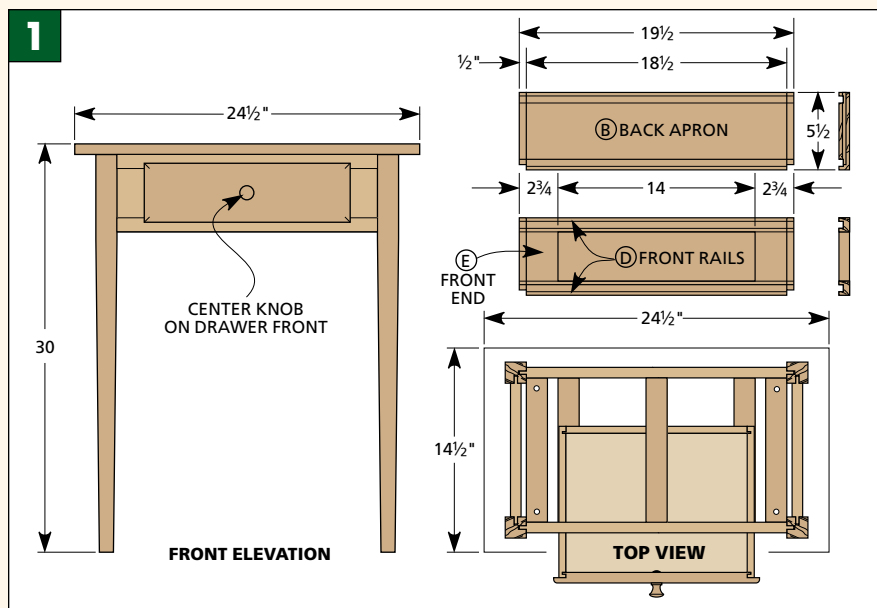
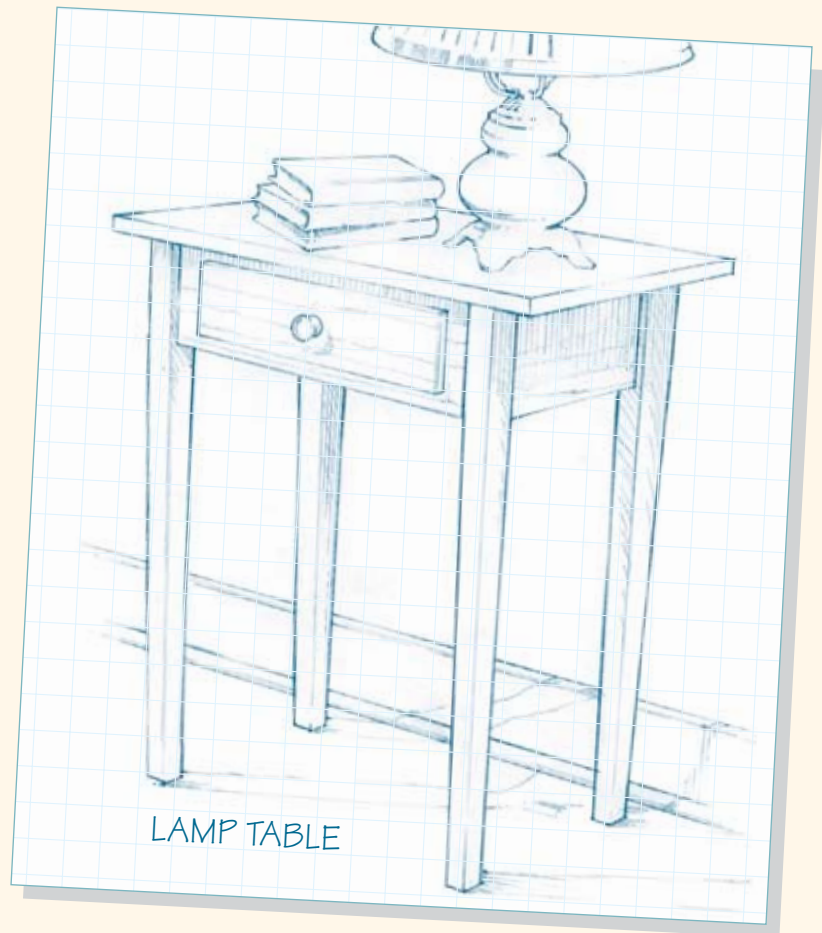

CHANGES TO MATERIALS AND HARDWARE

CHANGED PARTS

- B** Back Apron (1) $\frac{3}{4} \times 5\frac{1}{2} - 19\frac{1}{2}$
- D** Front Rails (2) $\frac{3}{4} \times 1 - 19\frac{1}{2}$
- J** Top (1) $\frac{3}{4} \times 14\frac{1}{2} - 24\frac{1}{2}$

Note: Only need 1 each of parts G, K, M, N. Only need 2 each of parts H, I, L. Do not need part F.

HARDWARE

- (1) #6 x $\frac{3}{4}$ " Rh woodscrews
- (4) #8 x $1\frac{1}{4}$ " Rh woodscrews
- (4) $\frac{3}{16}$ " flat washers
- (10) $\frac{3}{4}$ " brads
- (2) $\frac{5}{8}$ " brads
- (1) 1" -dia. cherry knob w/screw

LEG TAPERING JIG



When it was time to cut the tapers on the hall table legs, I was stumped at first. It was easy to make a jig to set the angle for the cuts on the first two sides of the legs. But then I'd have to take those angles into consideration when tapering the other two sides.

Sliding Platform

The jig I came up with is a sliding platform for the table saw. The great feature of this jig is that all you have to do is rotate the leg to taper the next side. The way the jig does this has to do with the centerpoint on the end of the leg. (More on how this works in a bit.)

For now, just mark the centerpoint on the bottom of the leg. To do this, draw lines on the bottom of the leg, connecting opposite corners (Step 1 on page 10). At the point where the lines cross, drill a $\frac{1}{4}$ "-dia. hole with a brad point bit and push in a $\frac{1}{4}$ "-dia. dowel.

PLATFORM. To build the jig, start with a piece of $\frac{3}{4}$ " plywood about 9" wide for the platform (A). Cut it to a length of 31" (Step 2 on page 10).

RUNNER. Next, cut a groove in the bottom of the platform and add a

hardwood runner (B) that will fit your miter gauge slot (Step 2). To determine the location of the groove, measure from your saw blade to the miter gauge slot and add 1". Cut the groove, then glue and screw the runner in place.

Finally, place the runner in the slot of the saw and trim off one edge of the platform (Step 3). This edge shows you exactly where the taper will be cut.

Fence

The jig has two fences that help align the leg for each cut. When a leg is mounted to the jig, the dowel slides into a hole in the rear fence (Step 5). After one side is tapered, the leg is rotated 90° to cut the next side. The dowel realigns the piece on the edge of the jig. But one of the problems I had was getting the hole in the fence in exactly the right position. Then I discovered a trick — actually two tricks.

REAR FENCE. First, cut the rear fence (C) to a width (height) to match the thickness of the leg. Then draw an "X" on the fence to match the pattern on the end of the leg (Detail in Step 4). Drill a $\frac{1}{4}$ " hole at the crosspoint.

The second trick has to do with

mounting the fence to the platform. In order to get a $\frac{1}{4}$ " taper on each side of the leg, the crosspoint on the rear fence has to be $\frac{1}{4}$ " closer to the path of the blade. So all you do is shift the whole rear fence so it extends $\frac{1}{4}$ " over the edge of the platform (Step 4).

SIDE FENCE. A side fence (D) mounted on the platform helps hold the top end of the leg. To position this fence, place the leg on the platform with the dowel mounted in the rear fence (Step 5). Then position the taper start line (near the top end of the leg) on the edge of the platform (Step 6). Now draw a line along the back edge of the leg to indicate the position of the side fence. Then screw the fence in place (Step 7).

HOLD-DOWN. To complete the jig, add a hold-down clamp. You can make this with a few scraps of wood (E, F) (Step 8). However, I like the ease of using a quick-release clamp as shown in the photo.

Cutting Tapers

To cut the tapers on the leg, mount the leg on the platform and push it through the blade (Step 9). Then simply loosen the clamp, rotate the leg, and cut the next side.

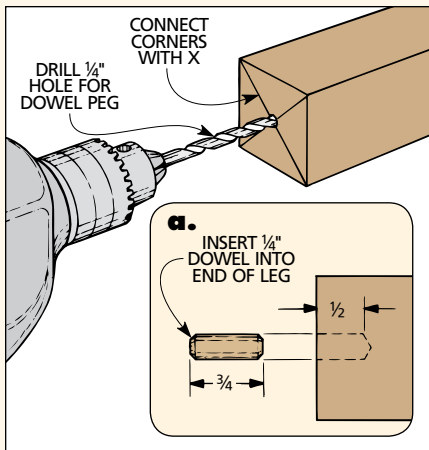

1 To find the center of the bottom of the leg, connect the opposite corners with an "X". Then drill a 1/2"-deep hole at this centerpoint and insert a 3/4" length of dowel.

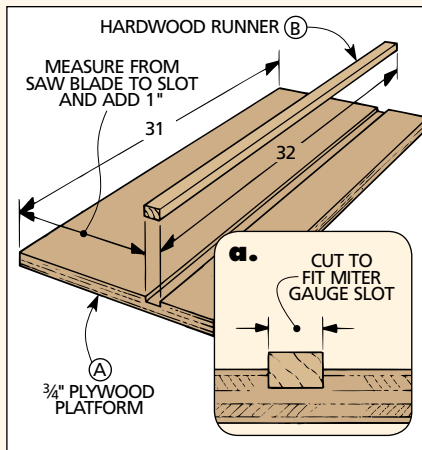

2 Use 3/4" plywood or MDF for the platform. Cut a 1/4"-deep groove in the bottom of the platform to hold a hardwood runner that fits your miter gauge slot.

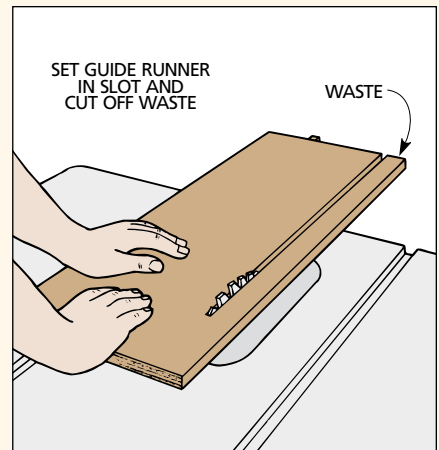

3 Put the runner in the miter gauge slot and trim the side of the platform. This gives you a reference edge that shows exactly where the blade cuts.

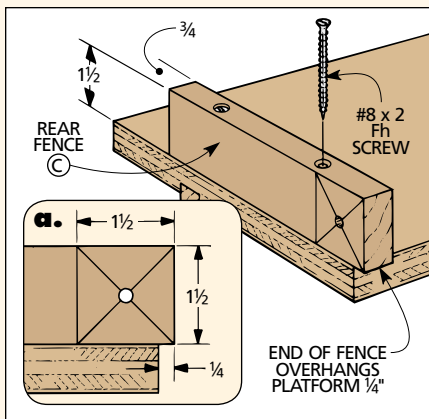

4 A rear fence that's the same width as the leg overhangs the edge 1/4". Make an "X" on the end to match the "X" on the leg. Drill a 1/4"-dia. hole at the crosspoint.

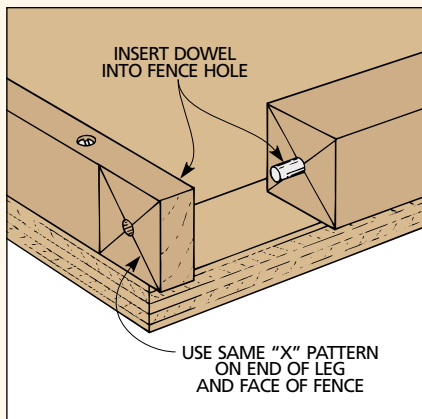

5 To position the side fence, first insert the dowel in the leg into the hole in the rear fence. (The dowel is trimmed off later to fill the hole in the leg.)

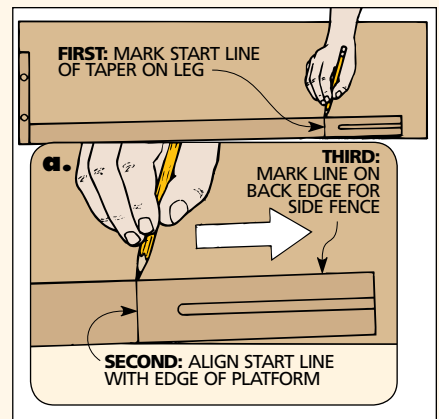

6 Next, you need to mark the taper start line on the leg. Then place this line on the jig's edge. Mark the location of the leg's back edge onto the platform.

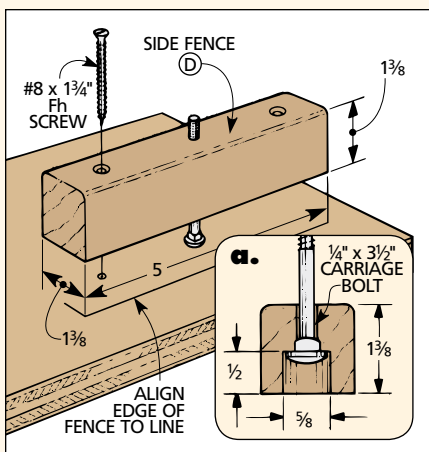

7 The side fence is shorter than the leg thickness. Align it with the line and screw it in place. Add a carriage bolt for a shop-made hold-down (next step).

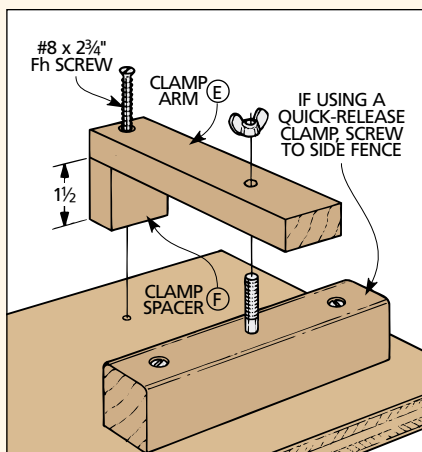

8 Use scrap to make a simple hold-down clamp. Tightening the wing nut applies pressure. (If a quick-release clamp is used, the fence should be 1 1/2" wide.)

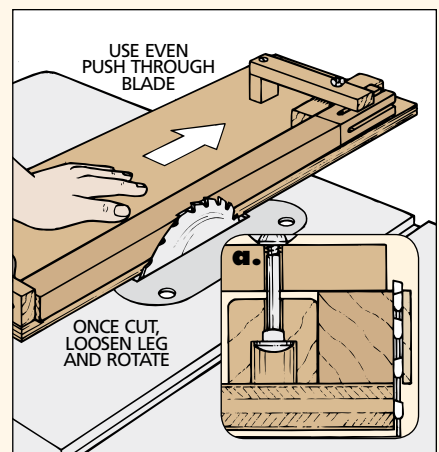

9 To cut tapers, position leg on the jig and push the platform past the blade. Rotate the leg one-quarter turn to make next cut. Then repeat for the other two cuts.

Tapering on the Jointer

Usually, you think of using a jointer to get a straight edge from one end of a workpiece to the other. But how about using the jointer to cut tapers? After all, a taper is a straight edge. It's just that it doesn't run the full length of the piece.

Another reason the jointer is an ideal tool for cutting tapers is that the jointer produces a clean, crisp cut that needs little (if any) sanding. And unlike a table saw, tapering on the jointer doesn't require any special jigs or complicated layouts. All you need is a roll of masking tape and a pencil.

Procedure

When cutting a long taper, like on the hall table, you don't taper the entire leg. Instead, there's a flat at the top where the leg is joined to the apron.

Note: Complete any joinery on the leg before it's tapered.

LOWER WORKPIECE. The basic idea behind tapering on the jointer is simple. Instead of starting the cut at the end of the workpiece, it's lifted up and the flat portion of the leg is pushed forward, past the cutterhead. Then the leg is lowered onto the cutterhead to start the taper. The trick is knowing where to lower the workpiece to as you start the cut.

REFERENCE LINES. To do this, I make two reference lines. One marks the start of the taper on the leg (Fig. 1).

The other line indicates the front edge of the jointer's outfeed table (Fig. 2). When the two marks align, the workpiece is lowered onto the jointer.

SNIFE. Since the workpiece is coming down at an angle, the knives will create a dished cut (snipe) at the beginning of the cut. To prevent this, I wrap two layers of masking tape around the leg (Fig. 3). This raises the workpiece above the cutterhead just enough to produce a smooth cut.

Depth of Cut

Another thing to keep in mind is the depth of cut. This determines how many passes over the jointer you'll have to make to get the finished taper.

To plan the cut, start with the amount of taper you want at the end of the leg and divide it by the depth of cut. For example, if your jointer is set for a $\frac{1}{16}$ " cut, four passes will cut a $\frac{1}{4}$ " taper.

But in practice, to allow for a cleanup pass, I adjust the infeed table so the cut is a hair ($\frac{1}{64}$ ") less. To do this, measure the gap between the infeed table and a straight stick laid across the outfeed table (see photo at right).

CUTTERGUARD. Before making your first cut, it's a good idea to get a feel for opening the cutterguard with a workpiece. This takes some practice — with the jointer turned off. What I've found works best is to slightly raise the end of the workpiece off the table



and use it to nudge the cutterguard open (Fig. 4 on the next page).

Cut Taper

With the setup complete, it's time to make some test cuts before moving on to the real leg pieces.

TEST CUT. Once you get the feel for opening the cutterguard, check

Measuring the Depth of Cut.

Place a straight piece of scrap on the jointer's outfeed table. Then measure the gap between it and the infeed table.

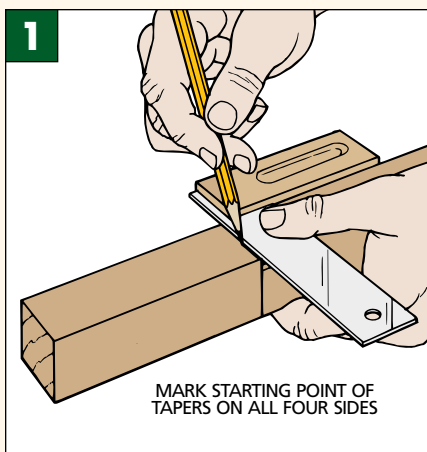

1 **Lay Out Tapers.** Using a try square and pencil, first lay out the starting point of the tapers around all four sides of the leg.

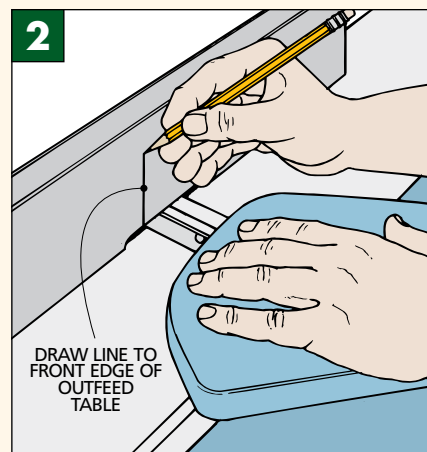

2 **Mark Outfeed Table.** Now make a pencil mark on the jointer fence to indicate the front edge of the outfeed table.

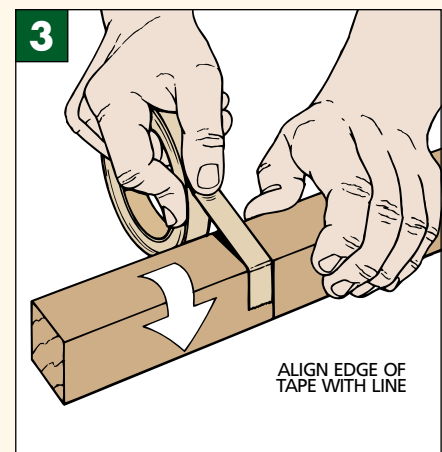

3 **Add Tape.** Then, to prevent the jointer knives from making a "dished" cut, wrap two layers of masking tape around the leg.

the setup by making a test cut. You should not have any snipe at the start or end of the cut.

Safety Note: Be sure to hook a push block over the end of the leg when you make the cut.

CUT TAPER. Now you're ready to taper the actual workpiece. Depending on the depth of cut, you'll need to make several passes on each side (Fig. 5). And since it can be easy to lose track of the cutting sequence, I just label the cutting order right on the masking tape (see photo at left).



When it's time to taper the fourth side of the leg, you'll have a tapered side facing the fence of

the jointer. If you press this face against the fence, the start of the taper will be angled. To prevent this, press the untapered top of the leg against the fence during the cut. This will leave a gap between the tapered face and the fence.

CLEANUP PASS. After the taper is cut on each side, all that's left to complete the job is to make one cleanup pass on each side. The goal is to take as light a pass as possible, yet still cut the taper right up to the layout line.

To do this, remove the masking tape and raise the infeed table until the knives just graze the line at the start of the taper (Fig. 6a). Then, instead of lowering the workpiece onto the cutterhead, make a full-length pass with the leg riding on the tapered side (Fig. 6).

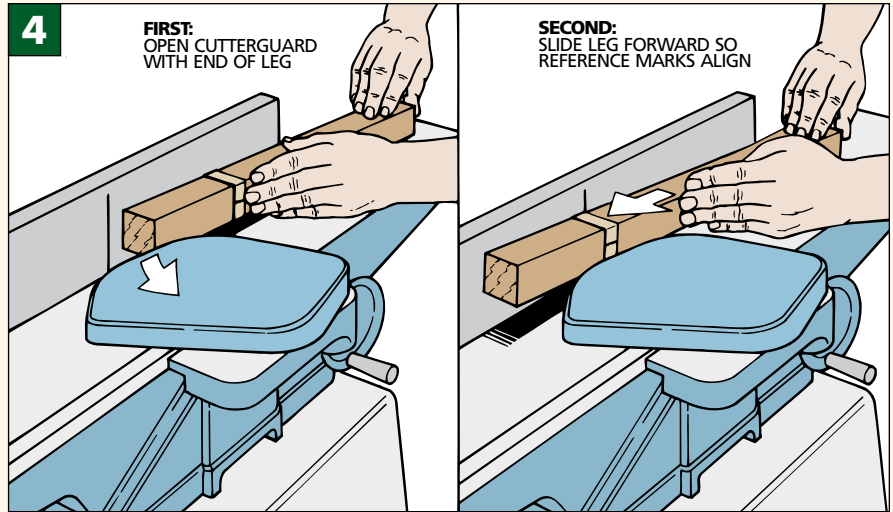

Position Leg. With the leg against the fence, raise the end slightly above the table. Now nudge the cutter guard open with the end of the leg and slide the workpiece forward until the reference mark on the leg aligns with the mark you made on the fence.

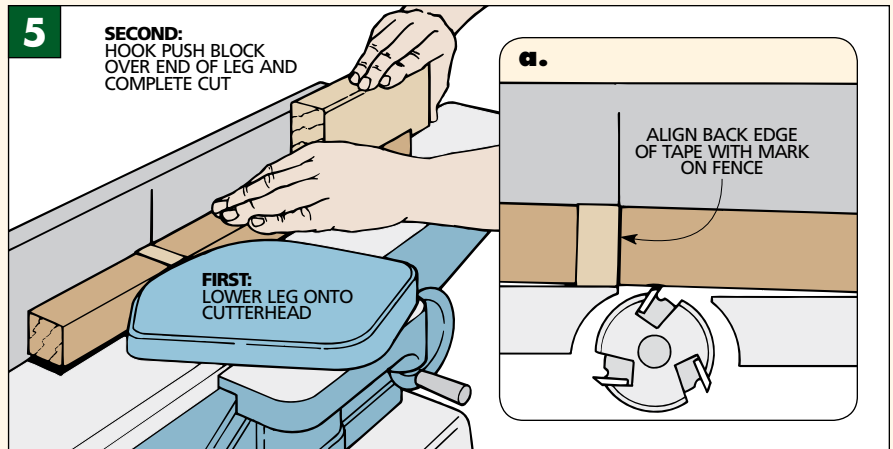

Begin Cut. When the back edge of the tape aligns with the mark on the fence, lower the leg down onto the cutterhead. Then hook a push block over the end of the leg and complete the cut.

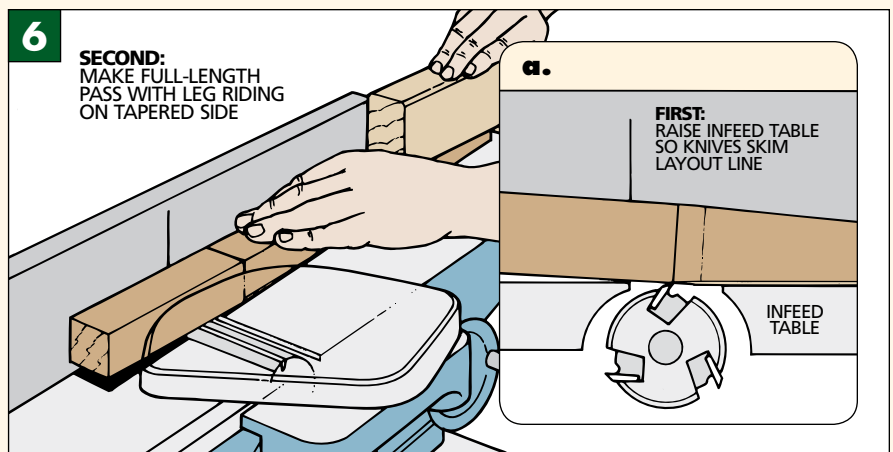

Cleanup Pass. After the taper is cut, remove the tape. Then center the layout line on the workpiece across the opening in the jointer table. After raising the infeed table until the knives just graze the line, make a full-length pass.