

Roland®

24-bit DIGITAL STUDIO WORKSTATION

VS-1880

USER GUIDE

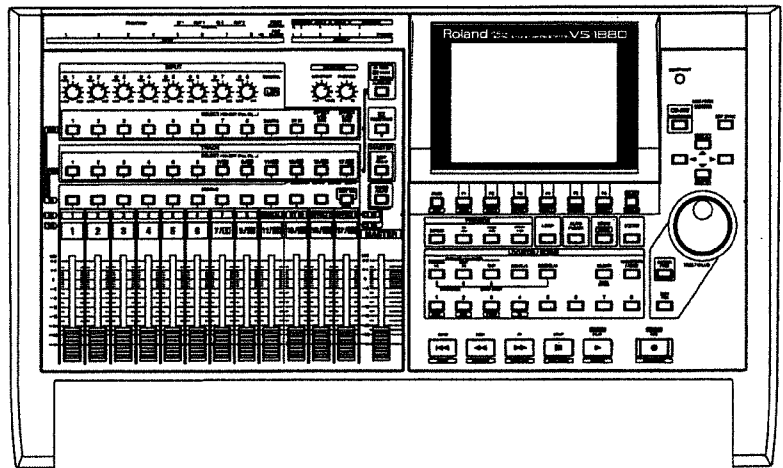

Before using this unit, carefully read the sections entitled: "IMPORTANT SAFETY INSTRUCTIONS" (Owner's Manual p. 2), "USING THE UNIT SAFELY" (Owner's Manual p. 3, 4), and "IMPORTANT NOTES" (Owner's Manual p. 5). These sections provide important information concerning the proper operation of the unit. Additionally, in order to feel assured that you have gained a good grasp of every feature provided by your new unit, User Guide, Owner's Manual, and Appendices should be read in their entirety. The manual should be saved and kept on hand as a convenient reference.

Copyright © 2000 ROLAND CORPORATION

All rights reserved. No part of this publication may be reproduced in any form without the written permission of ROLAND CORPORATION.

Roland Website <http://www.roland.co.jp/>

Contents

Preparations	5
Required Preparations	5
Installing an Internal Hard Disk	5
Cautions When Installing a Hard Disk	5
Installing Effect Expansion Boards	8
Cautions When Installing an Effect Expansion Board	8
Installation de la carte d'extension d'effets	11
Précautions lors de l'installation de la carte d'extension d'effets	11
Basic Connections (Power Supply, Audio Devices and Headphones).....	13
Turning On the Power	14
Adjusting the Display Contrast	15
If You Do Not Understand the Display or Don't Know What to Do	15
Mixer and System Initialize	15
Setting the Date and Time of the Internal Clock.....	16
Turning Off the Power	19
If "STORE Current?" is Displayed	20
Listening to the Demo Songs	21
About the Demo Songs	21
Playing Back the Demo Song	21
Viewing the Level Meters	23
Adjusting the Overall Volume	25
Adjusting the Volume of an Individual Track.....	25
Adjusting the Headphone Volume.....	25
Listening to the Demo Song with a Different Arrangement (Scene)	26
Listening to the Other Demo Song (Song Select)	27
Deleting Unneeded Songs (Song Erase).....	30
Making a Multi-Track Recording.....	33
Creating a New Song (Song New)	34
Connecting Microphones	38
Cautions When Connecting Microphones	39
Adjusting the Input Sensitivity	40
Recording On a Track	42
Playing Back the Performance You Recorded.....	44
Canceling the Recording	45
Checking the Time Available for Recording (Remaining Time).....	45
Canceling a Recorded Result (Undo/Redo)	47
Re-Recording a Specified Portion (Punch-In/Punch-Out)	50
Erasing Just a Portion of a Recording (Track Erase)	52
Deleting an Erased Recording from the Disk (Song Optimize)	55
Recording On a V-Track	57
Comparing the Recorded Content of Two V-Tracks	59
Recording On Other Tracks	61
Playing Back Two or More Tracks	64
Adjust the Volume Balance of the Tracks.....	64
Adjusting the Stereo Position of Each Track.....	65
Adjusting the Tone of Each Track	67
Saving Your Performance (Song Store).....	69
Changing the Partition Size (Drive Initialize)	70

Contents

Using Effects (When VS8F-2s are Installed).....	73
Applying a Send/Return Type Effect During Playback.....	74
Applying a Send/Return Type Effect Only to the Monitor Sound as You Record	78
Switching Effects During Playback	83
Applying a Send/Return Type Effect While You Record	86
Applying an Insertion-Type Effect During Playback.....	92
Inserting the Same Effect into Another Track as Well.....	95
If You Wish to Use the Same Effect Both as Send/Return and Insertion	95
Applying an Insertion-Type Effect During Recording	96
Add Finishing Touches to Your Song.....	101
Combining the Performances of Multiple Tracks (Track Bouncing)	101
Erasing an Unwanted Portion (Track Cut)	108
Selecting the Portion that will be Written to the CD-R Disc.....	109
Deleting an Unwanted Portion At the End of the Song	110
Deleting an Unwanted Portion At the Beginning of the Song	112
Mixing down to the mastering tracks (Mastering Room)	114
Mixing down to the mastering tracks (MST TR)	114
Playing back the mastering tracks	120
Mixing down while inserting effects	122
Adding Track Number Markers	128
Assigning Track Numbers	129
Creating an Original Audio CD	130
Connecting the CD-R Drive/CD-RW Drive.....	130
Writing a Song to a CD-R Disc	130
Auditioning the Song You Wrote.....	136
Index.....	138

Preparations

Required Preparations

The VS-1880 is an audio recorder that allows multi-track recording to a hard disk. To make a multi-track recording, you will need at least the following items.

- VS-1880 (1 unit)
- Power cable (1: included)
- Internal IDE hard disk (HDP88 series: sold separately in some countries)
- Audio device for master output, monitor output, or headphones (sold separately)
- Microphone or other audio source to record, such as an electric guitar, synthesizer, or CD player etc. (sold separately)

User guide will also explain the use of the following equipment, which you may purchase as desired.

- VS8F-2 (effect expansion board for internal installation: sold separately)
- External CD-R/CD-RW drive (sold separately)



The explanations in this manual include illustrations that depict what should typically be shown by the display. Note, however, that your unit may incorporate a newer, enhanced version of the system, so what you actually see in the display may not always match what appears in the manual.



IDE (Appendices p.12)

Installing an Internal Hard Disk

In some countries, VS-1880's do not come with the Hard Disk installed.

A Roland HDP88 series hard disk (sold separately in some countries) can be installed in the VS-1880. In order to take full advantage of the VS-1880's functionality for the number of tracks that can be recorded/played back simultaneously, we recommend that you install an 2100 MB or higher model.

Cautions When Installing a Hard Disk

- Use a Phillips screwdriver that is suitable for the size of the screw (a number 2 screwdriver). If an unsuitable screwdriver is used, the head of the screw may be stripped.
- To remove a screw, rotate the screwdriver counter-clockwise. To tighten a screw, rotate the screwdriver clockwise.
- When installing a hard disk, remove only the specified screws.
- Be careful that the screws you remove do not drop into the interior of the VS-1880.
- Do not leave the front panel cover in a detached state. Be sure to reattach it after the hard disk has been installed.
- Do not touch any of the printed circuit pathways or connection terminals.
- Be careful not to cut your hand on the edge of the installation bay.
- When circuit board installation is complete, double-check your work.

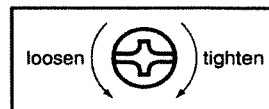

Preparations

- 1** Turn off the power of the VS-1880 and of all connected devices, and disconnect all cables from the VS-1880.
- 2** Remove the front panel cover from the VS-1880.

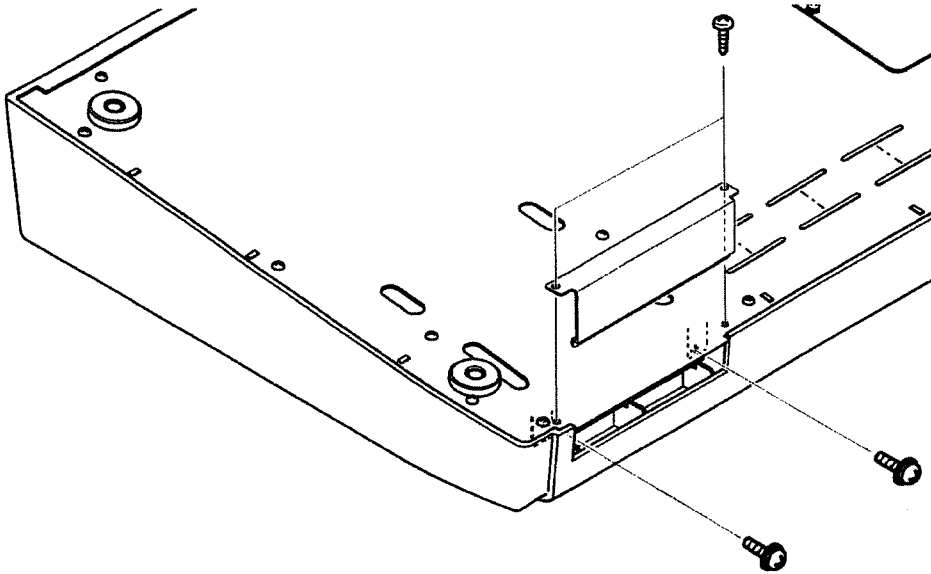

- 3** With the warning label of the hard disk facing upward, slide it gently into the installation bay as far as it will go. You can hook the indentation of the attachment hardware over the protrusion on the chassis of the VS-1880.

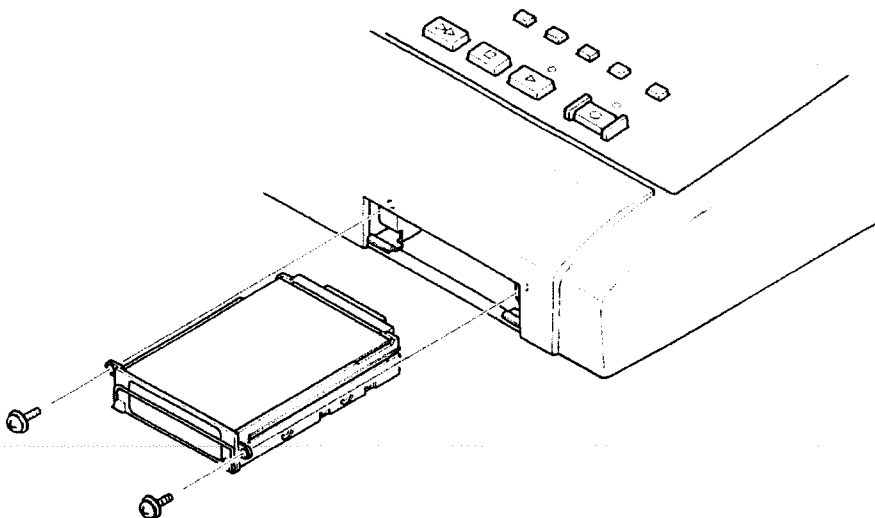

- 4 After the hard disk has been inserted, use the screws that you removed earlier to fasten the hard disk in place.
- 5 Fold down the handle on the front of the hard disk, and reattach the front panel cover as it originally was. This completes installation of the hard disk.
- 6 As described in "Turning On the Power" (p. 14), turn on the power and verify that the VS-1880 starts up correctly.

If the Display Indicates "Not Found any Drives"

The internal hard disk was not recognized correctly. Use the rear panel power switch to turn off the power, and re-install the hard disk correctly.

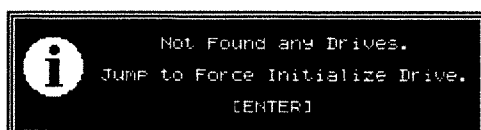

NOTE

When transporting the VS-1880, please pack it in the original carton and shock-absorbing material, or the equivalent. If an internal IDE hard disk (HDP88 series) is installed, reverse the installation procedure to remove it from the VS-1880, pack the hard disk in its own packing carton, and place it in the specified location of the VS-1880's packing carton for transport. **If the VS-1880 is transported with the hard disk installed, song data may be lost, or the hard disk itself may be damaged.**

Installing Effect Expansion Boards

A VS8F-2 effect expansion board is optionally available. When one or two VS8F-2 boards are installed, you will be able to use up to two stereo effects for each board without connecting any additional equipment to the VS-1880. Up to two of these effect expansion boards may be installed in the VS-1880. In order to take full advantage of the VS-1880's functionality, we recommend that you install at least one effect expansion board.

Cautions When Installing an Effect Expansion Board

- To avoid the risk of damage to internal components that can be caused by static electricity, please carefully observe the following whenever you handle the board.
- Before you touch the board, always first grasp a metal object (such as a water pipe), so you are sure that any static electricity you might have been carrying has been discharged.
- When handling the board, grasp it only by its edges. Avoid touching any of the electronic components or connectors.
- Save the bag in which the board was originally shipped, and put the board back into it whenever you need to store or transport it.
- Use a Phillips screwdriver that is suitable for the size of the screw (a number 2 screwdriver). If an unsuitable screwdriver is used, the head of the screw may be stripped.
- To remove a screw, rotate the screwdriver counter-clockwise. To tighten a screw, rotate the screwdriver clockwise.
- When installing effect expansion boards, remove only the specified screws.
- Be careful that the screws you remove do not drop into the interior of the VS-1880.
- Do not leave the bottom cover in a detached state. Be sure to reattach it after the effect expansion boards have been installed.
- Do not touch any of the printed circuit pathways or connection terminals.
- Be careful not to cut your hand on the edge of the installation bay.
- Never use excessive force when installing a circuit board. If it doesn't fit properly on the first attempt, remove the board and try again.
- When circuit board installation is complete, double-check your work.



- 1** Before installing the VS8F-2, turn off the power of the VS-1880 and all connected devices, and disconnect all cables from the VS-1880.
- 2** Turn the VS-1880 on its back, and remove only the screws shown in the following diagram.
- 3** Inside, there are two connectors and six resin pins. Insert the connectors of the VS8F-2 into the internal connectors, and simultaneously insert the resin pins into the holes of the VS8F-2 to fasten the unit in place. Be careful not to touch the lithium battery of the VS-1880.

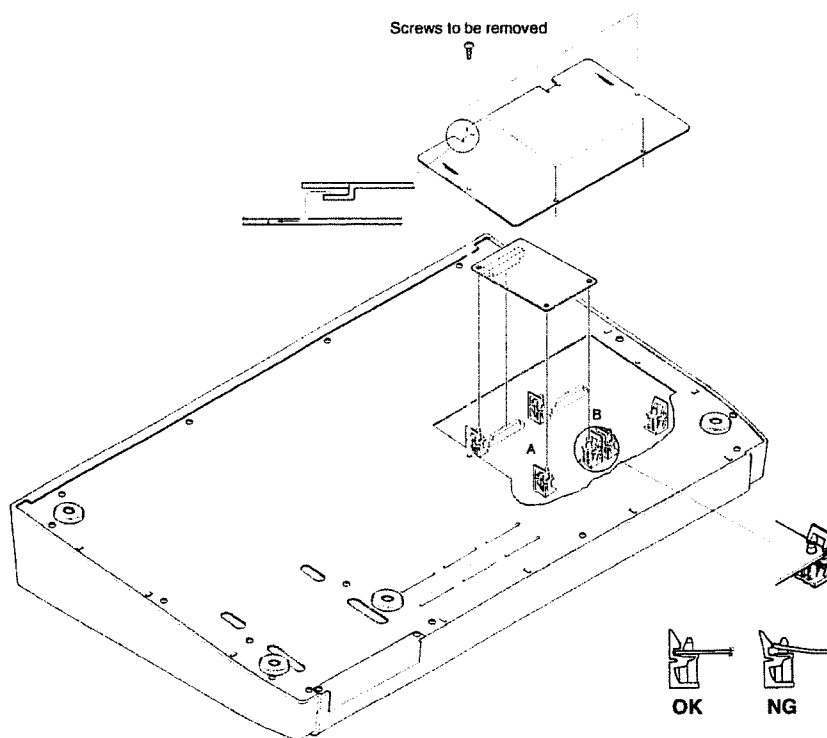

NOTE

If you are installing only one effect expansion board, connect it to EFFECT A.

- 4** Use the screws that you removed in step 2 to fasten the cover back in place. This completes installation of the effect expansion board.

Preparations

- 5 Connect the cables that you disconnected earlier.
- 6 Turn on the power, as described in "Turning On the Power" (p. 14).
- 7 After the VS-1880 has finished its start up procedure, hold down [SHIFT] and press [F3 (EFFECT A)] to verify that the Effect A menu appears.

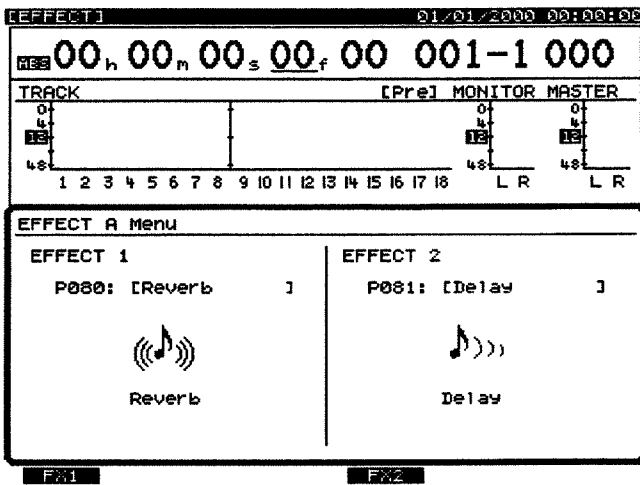

If the Display Indicates "No Effect Board"

The internal effect expansion board was not detected correctly. Turn off the power (Shutdown operation), as described in "Turning Off the Power" (p. 19), and re-install the effect expansion board correctly.

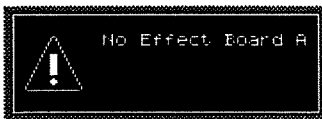

NOTE

If you are installing two effect expansion boards, hold down [SHIFT] and press [F4 (EFFECT B)] to verify that the Effect B menu appears.

Installation de la carte d'extension d'effets

Quand une ou deux cartes VS8F-2 sont installées, il est possible d'utiliser jusqu'à 2 effets stéréo pour chaque carte sans brancher aucun équipement additionnel au VS-1880. Deux de ces cartes peuvent être installées dans le VS-1880. Il est recommandé d'installer au moins une carte d'extension à effet pour pouvoir utiliser pleinement le VS-1880.

Précautions lors de l'installation de la carte d'extension d'effets

- Pour éviter tout dommage des composants internes pouvant provenir de l'électricité statique, veuillez suivre les conseils suivants quand vous installez la carte.
- Avant de toucher la carte, saisissez toujours un objet métallique (tuyau d'eau ou autre) pour être sûr que l'électricité statique se décharge.
- Quand vous saisissez la carte, prenez-la par les bords. Evitez de toucher les composants électroniques ou les connecteurs.
- Conservez le sac dans lequel la carte était emballée et remettez la carte dedans pour l'expédier ou l'entreposer.
- Utiliser un tournevis cruciforme correspondant à la taille de la vis (un tournevis numéro 2). En cas d'utilisation d'un tournevis inapproprié, la tête de la vis pourrait être endommagée.
- Pour enlever les vis, tourner le tournevis dans le sens contraire des aiguilles d'une montre. Pour resserrer, tourner dans le sens des aiguilles d'une montre.

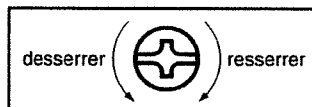

- Lors de l'insertion de la carte d'extension d'effets, enlevez seulement les vis indiquées dans les instructions.
- Veillez à ne pas laisser tomber de vis dans le châssis du VS-1880.
- Ne pas laisser le panneau de protection avant détaché. S'assurer de l'avoir rattacher après avoir installé le disque dur.
- Ne touchez aucun des circuits imprimés ni les bornes de connexion.
- Veillez à ne pas vous couper les doigts sur le bord de l'ouverture d'installation.
- Ne jamais forcer quand vous installez une carte de circuits. Si la carte ne rentre pas correctement, ressortez-la et ressayer.
- Quand la carte est installée, vérifiez si l'installation est correcte.

Preparations

- 1 Éteindre le VS-1880 et tous les appareils qui y sont reliés et débrancher tous les câbles du VS-1880.
- 2 Retournez le VS-1880 et enlevez seulement les vis indiquées sur la figure.
- 3 A l'intérieur se trouvent deux connecteurs et 6 goupilles de plastique. Reliez les connecteurs de la VS8F-2 à ceux du VS-1880 tout en insérant les goupilles de plastique dans les orifices de la VS8F-2. Veillez à ce que la VS8F-2 ne touche pas la pile au lithium du VS-1880.

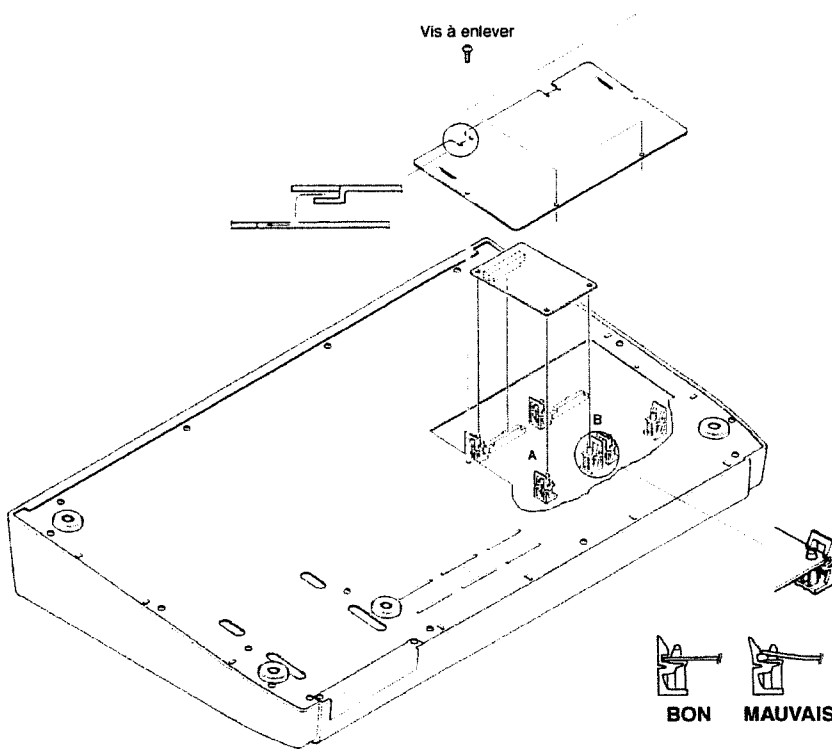

Si vous installez une seule carte d'extension d'effets, installez-la dans EFFECT A.

- 4 Reposez le couvercle en remettant les vis enlevées (comme spécifié) à l'étape 2.
- 5 L'installation de la carte d'extension d'effets est terminée.

- 6 Rabranchez les câbles.
- 7 Mettez le VS-1880 sous tension en procédant comme indiqué dans "Turning On the Power" (p. 14).
- 8 Si le VS-1880 démarre correctement, appuyez sur [F3 (EFFECT A)] tout en tenant [SHIFT] enfoncé et vérifiez si le menu d'effet A apparaît à l'écran.

Si "No Effect Board" apparaît à l'écran

Ce message signifie que la carte d'extension d'effets n'a pas été reconnue correctement. Mettez l'appareil hors service et hors tension comme indiqué dans "Mise hors tension", puis réinstallez correctement le VS8F-2.

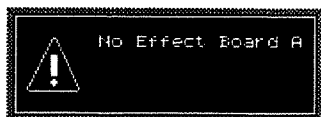

Basic Connections (Power Supply, Audio Devices and Headphones)

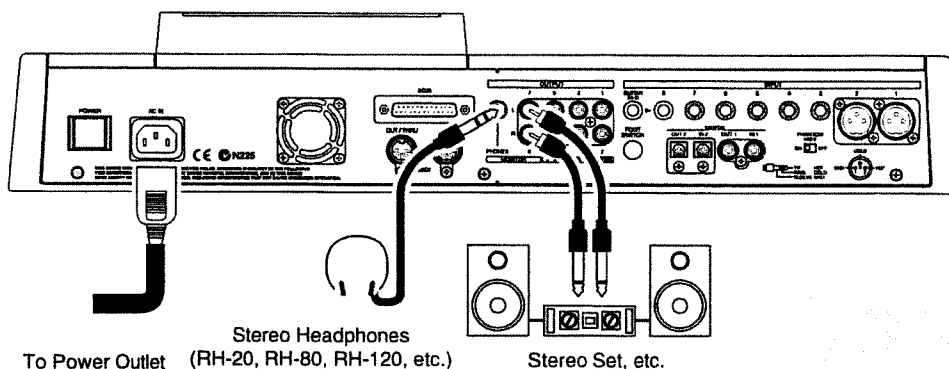

If you are using headphones, connect them to the rear panel PHONES jack. The PHONES jack will output the same signal as the MONITOR jacks.

When you purchase the VS-1880, it will be set so that all analog audio signals are output from the MASTER jacks. The MONITOR jacks will output the same sound as the MASTER jacks.



To prevent malfunction and/or damage to speakers or other devices, always turn down the volume before making any connections.



For details refer to "Determining Output" (Owner's Manual p.76).

Preparations

Turning On the Power

- 1 The rear panel POWER switch turns on the power of the VS-1880. When the VS-1880 starts up correctly, the following display will appear.

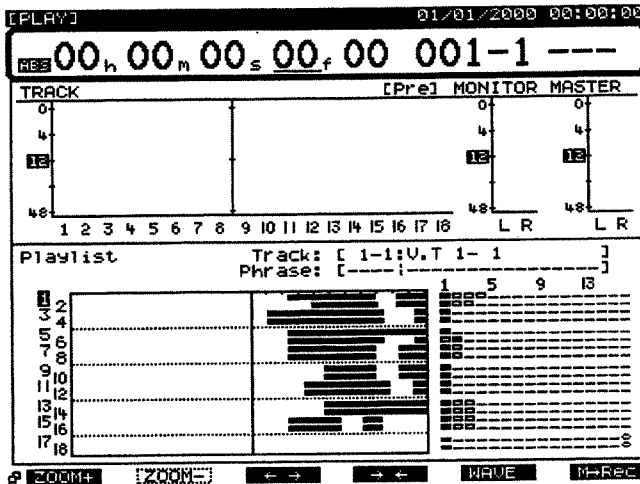

- 2 Turn on the power of your audio system.
- 3 Raise the volume of your audio system to an appropriate level.

If the Display Indicates “Not Found any Drives”

No hard disk is installed. In this case, the VS-1880 cannot be used.

If this message appears even though a hard disk has been installed, the hard disk is not being detected correctly. Use the rear panel power switch to turn off the VS-1880, check that the hard disk is installed properly.

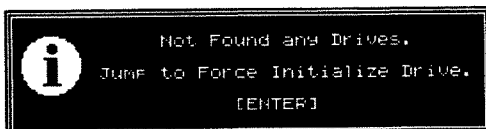

NOTE

When the power is turned on, the disk drive will be detected, and necessary data will be read. For this reason there will be an interval of time before operation can begin.

NOTE

Once the connections have been completed (p. 13), turn on power to your various devices in the order specified. By turning on devices in the wrong order, you risk causing malfunction and/or damage to speakers and other devices.

Always make sure to have the volume level turned down before switching on power. Even with the volume all the way down, you may still hear some sound when the power is switched on, but this is normal, and does not indicate a malfunction.

Adjusting the Display Contrast

The text or icons in the VS-1880's display may be difficult to read immediately after the unit is turned on or after it has been used for long periods, or depending on the environment in which the unit is used. If this occurs, rotate the CONTRAST knob located at the right side of the display to adjust the display contrast.

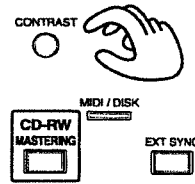

If You Do Not Understand the Display or Don't Know What to Do

If an unfamiliar display appears or if you do not know how you arrived at the current condition, press [PLAY (DISPLAY)]. This will return you to the initial power-on screen, allowing you to re-do the procedure from the beginning.

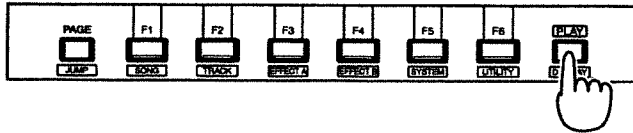

- If you attempt to perform an incorrect operation or if the specified operation cannot be executed, an error message will appear in the display. Please refer to "Error Messages" (Appendices p.9) and take the appropriate action.
- If the results are not as described in the User Guide or Owner's Manual even though you have followed the specified steps, please refer to "Troubleshooting" (Appendices p.5).
- If the information in "Troubleshooting" does not resolve the problem, contact a nearby Roland Service Center or authorized Roland Distributor.

Mixer and System Initialize

You can restore the default parameter settings of a song. This is convenient when you have made many changes to the Input Mixer, the Track Mixer, the Master Block, as well as changes in the System Menu screens, and you want to quickly restore the VS-1880 to its default settings.

1

Hold [SHIFT] and press [F5 (SYSTEM)]. The System Menu icon is displayed. If the System Menu icon does not appear, press [F6 (EXIT)].

2

Press [F1 (INIT)]. If "INIT" does not appear above [F1], first press [PAGE] until "INIT" appears, and then press [F1 (INIT)].

NOTE

After initializing mixer and system settings, many settings will not be affected. Some of the settings that are not affected by Mixer and System Initialize include song, Scene, tempo map, and sync track data. Additionally, the IDE drive, SCSI ID, Scene Mode, Shift Lock, and Numerics Type settings are not changed as a result of Mixer/System Initialize.

Preparations

- 3 “Init Mixer/System PRM Sure ?”—“Do you want to restore the initial mixer and system parameters?”—appears in the display. Press [YES]. If you want to cancel the operation, press [NO].
- 4 When the default settings are restored, the System Menu icon appears in the display.
- 5 Press [PLAY (DISPLAY)] to return to the Playlist display.

Setting the Date and Time of the Internal Clock

The VS-1880 contains a clock. When you record a performance, a time stamp is added which indicates the date and time of the recording. This is a convenience that helps you keep track of the date or order in which recordings were made. After turning on the power for the first time after purchase, please use the following procedure to set the date and time of the internal clock.

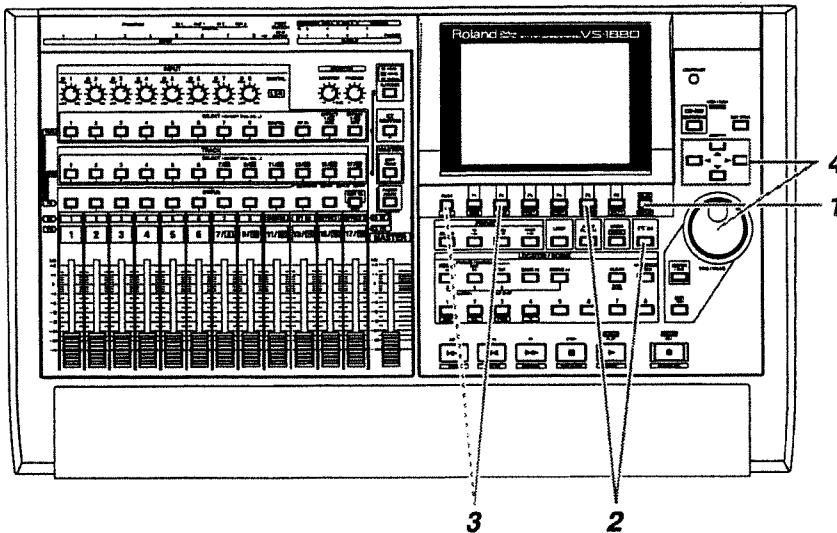

- 1 Press [PLAY (DISPLAY)].
- 2 Hold down [SHIFT] and press [F5 (SYSTEM)]. The System Menu icon will appear. If the System Menu icon does not appear, press [F6 (EXIT)].

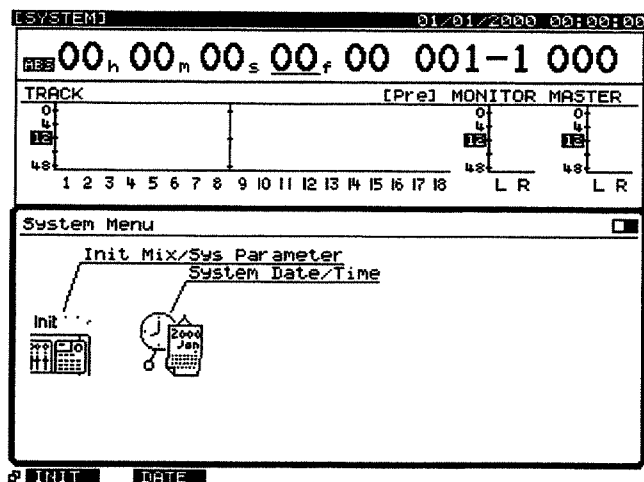

3 Press [F2 (DATE)]. If [F2] does not show "DATE," press [PAGE] so that it displays "DATE," and then press [F2 (DATE)].

4 Use [▲] [▼] [◀] [▶] to move the cursor, and use the TIME/VALUE dial to set each value. You can refer to the calendar that is displayed.

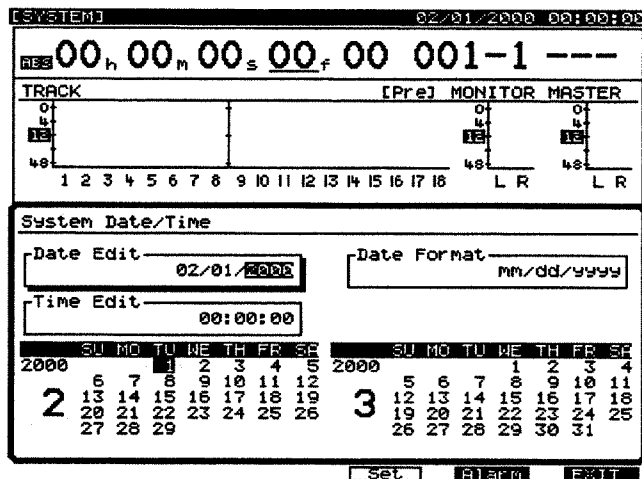

Date Edit

Set the year, month, and day.

Preparations

Date Format

Select how the date will be displayed. (The examples shown here are for February 1, 2000.)

mm/dd/yyyy:	month/day/year (Example: 02/01/2000)
dd/mm/yyyy:	day/month/year (Example: 01/02/2000)
yyyy/mm/dd:	year/month/day (Example: 2000/02/01)
MMM. dd, 'YY:	month/day/year (Example: Feb. 01, '00)
dd MMM 'YY:	day/month/year (Example: 01 Feb '00)

Time Edit

Set the current time in 24-hour format.

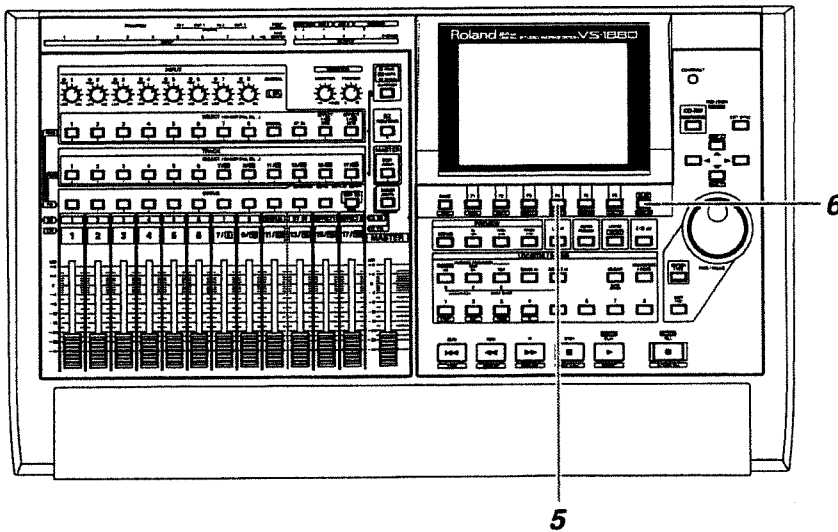

5 After setting the date the time, press [F4 (Set)] at the moment that the specified time arrives. The specified time will take effect at that moment.

6 Press [PLAY (DISPLAY)] to return to the original display screen.

Replacing the Internal Battery

When the internal battery runs down, the following display will appear. Since internal settings will be lost if the battery runs down completely, please replace it as soon as possible. You must contact a Roland Service Center to have the battery replaced.

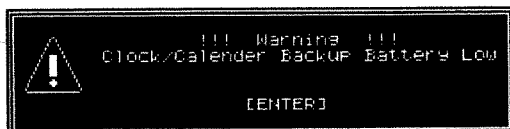

NOTE

The internal clock operates on a battery. There is no need to perform this operation the second and subsequent times you turn on the VS-1880. However, you may set the clock again if for some reason it should become inaccurate.

Turning Off the Power

If you simply turn off the power, not only can recorded content be lost, but the VS-1880 itself could malfunction. In order to safeguard the recorded performance and turn off the power safely, you must perform the Shutdown procedure when you are finished.

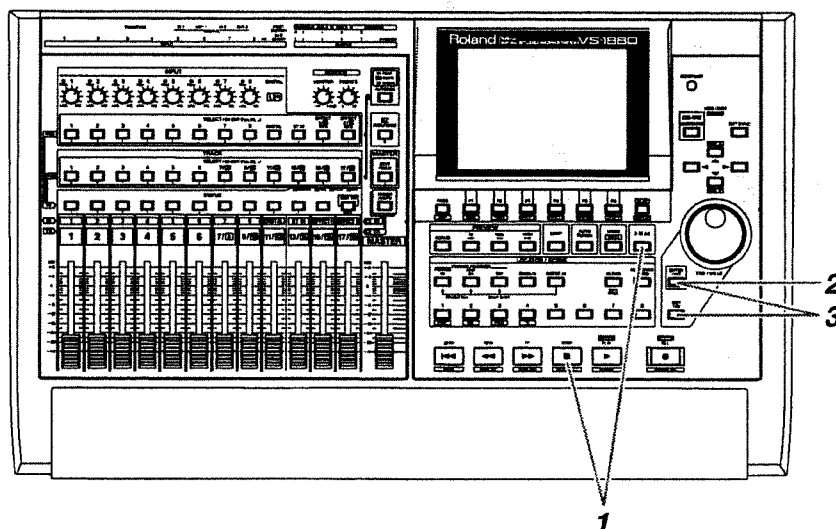

- 1** Hold down [SHIFT] and press [SHUT/EJECT (STOP)].
- 2** "SHUTDOWN/EJECT ?" will be displayed. Press [YES].



- 3** "STORE Current?" (store the current song?) will be displayed. If you wish to store the currently selected song, press [YES]. If you do not need to save it, press [NO]. However, this display will not appear in the case of a demo song or if the song is protected (i.e., cannot be edited).



Shutdown (Appendices p.13)



Current Song (Appendices p.12)



For details refer to "Protecting Songs (Song Protect)" (Owner's manual p.51)

Preparations

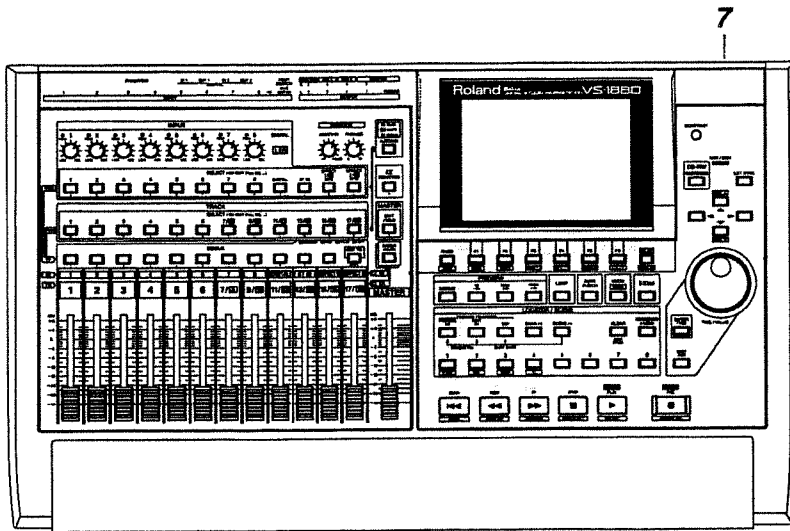

- 4** When the shutdown procedure ends correctly, the display will indicate "PowerOFF/RESTART" (turn off the power / restart).



- 5** Lower the volume of your audio equipment.

- 6** Turn off the power of your audio equipment.

- 7** Use the rear panel POWER switch to turn off the VS-1880.



After the power is turned off, the hard disk will continue rotating for a time due to inertia. During this time, applying physical shock to the VS-1880 may damage the disk. Before moving a VS-1880 that contains a hard disk, wait approximately 30 seconds after turning off the power.

If "STORE Current?" is Displayed

When you execute various operations (including Shut-Down), "STORE Current?" (Store the current song?) may be displayed. This message asks whether or not you wish to store the currently selected song to disk. If you wish to store the song before continuing with the operation, press [YES]. If you do not need to save the song (i.e., if you wish to discard the recording and editing that was done up to that point, and revert to the condition in which the song was last saved), press [NO].



Listening to the Demo Songs

The VS-1880 contains pre-recorded demo songs. Here's how to listen to the demo songs.

About the Demo Songs

The VS-1880 contains multiple demo songs. With the factory settings, the demo song "Seems So Right" is the current song. It contains 16 playback tracks in addition to numerous Virtual tracks.



For details refer to "Compatibility with Other VS Recorders" (Owner's manual p.243)

Playing Back the Demo Song

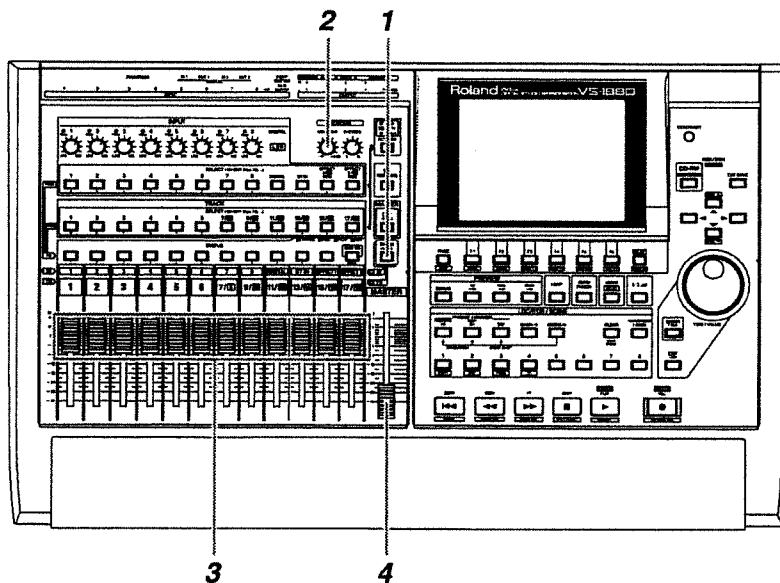

Using these demo songs for any purpose other than personal enjoyment without permission of the copyright owner is prohibited by law. The musical data of the demo song will not be transmitted from the MIDI OUT connector.

- 1** Press [FADER] so that the TR (track) indicator is lit.
- 2** Set the MONITOR knob to the 0 dB position (3 o'clock).
- 3** Set all channel faders to the 0 dB position.
- 4** Lower the master fader to the lowest position.

Listening to the Demo Songs

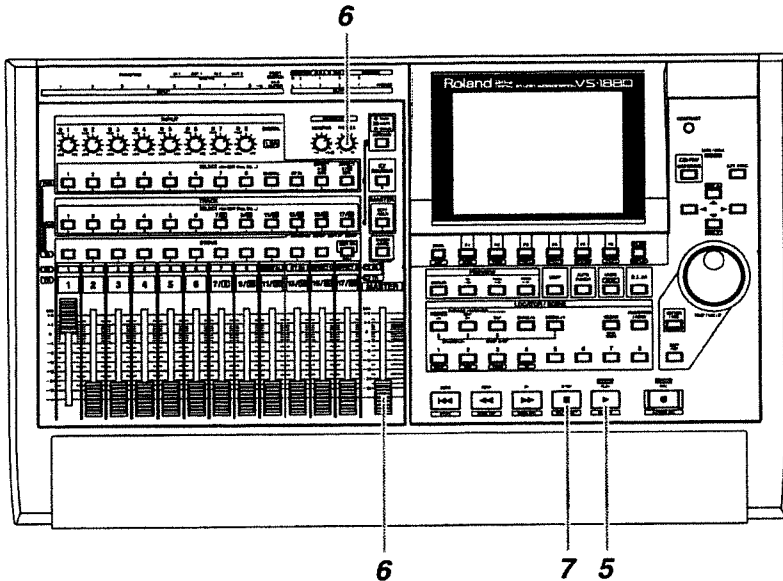

- 5 Press [PLAY]. The demo song will playback.
- 6 Slowly raise the master fader to adjust the volume. The playback time, level meters, and playback status of each track (playlist) etc. will be displayed. To adjust the volume of the headphones, rotate the PHONES knob.

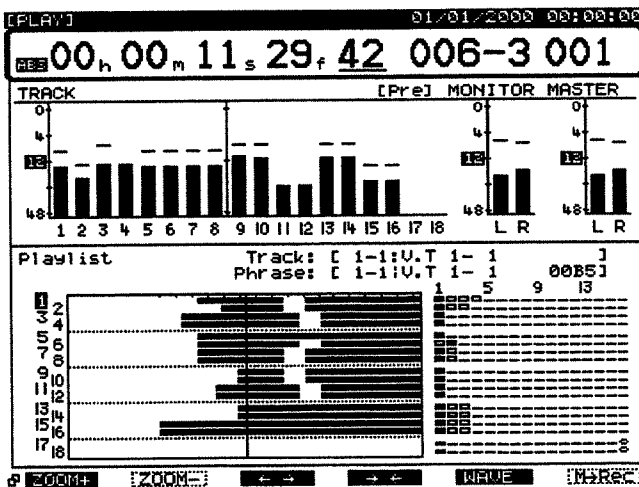

- 7 When playback ends, press [STOP]. The demo playback will stop.

Viewing the Level Meters

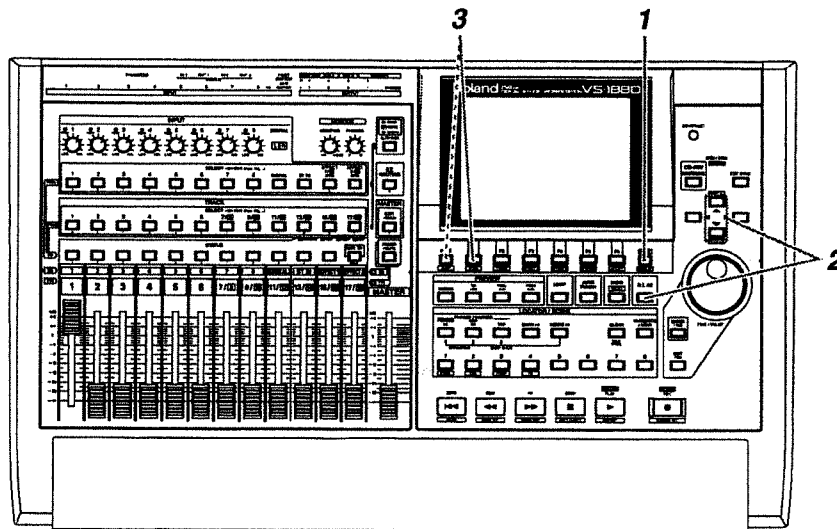

- 1 Press [PLAY (DISPLAY)].
- 2 Hold down [SHIFT] and press [▲] or [▼] so that the middle section of the display is enclosed in a heavy frame.
- 3 Press [F1 (LMTrk)]. If [F1] does not indicate "LMTrk," first press [PAGE] until "LMTrk" appears, and then press [F1 (LMTrk)]. The level meters will show the volume level of the playback tracks.

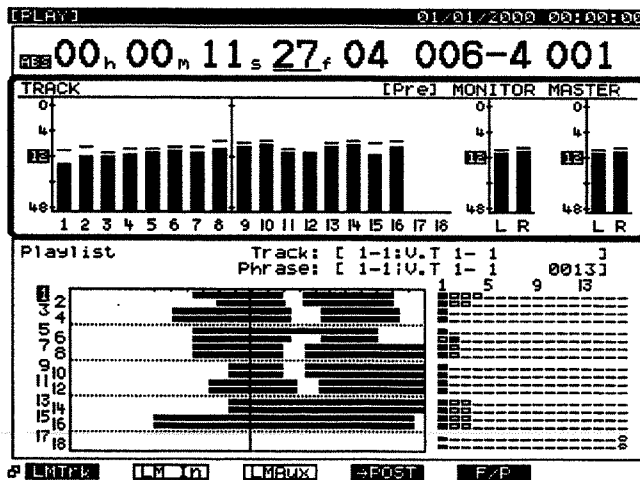

Listening to the Demo Songs

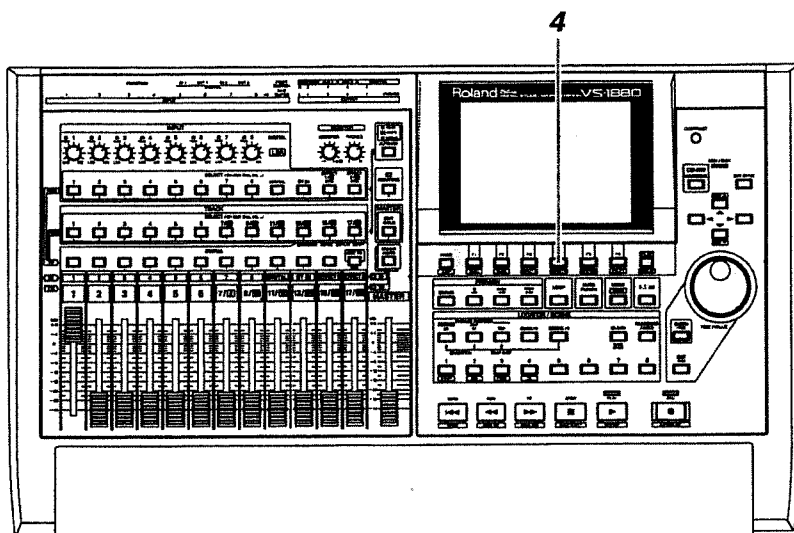

- 4** When you press [F4 (→PRE)], the Pre Level display will appear. Since this shows the volume levels before the signal passes through the channel faders, the level meter display will not change when you operate the channel faders. When you press [F4 (→POST)] the Post Level display will appear. Since this shows the volume levels after the signal passes through the channel faders, the level meter display will be affected when you operate the channel faders. The upper of the central part of the screen shows whether the Pre Levels or Post Levels are currently displayed.

Listening to the Demo Songs

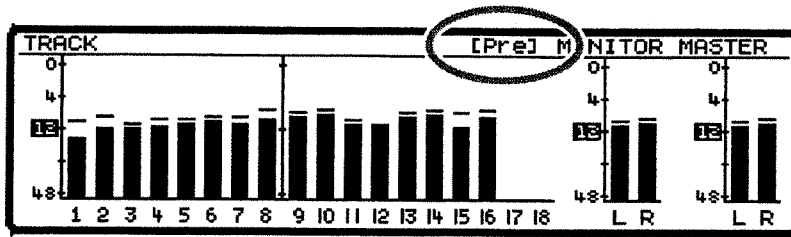

Pre level

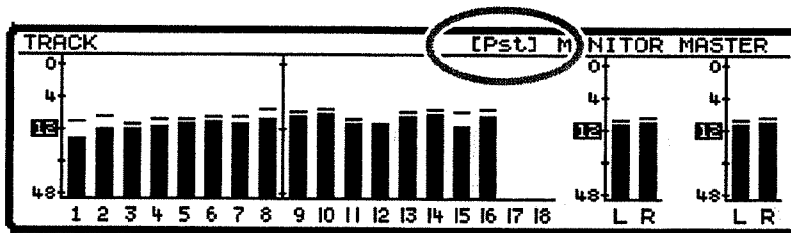

Post level



For details refer to "Mixer Section Block Diagram" (Appendices p.128)



The MONITOR level and MASTER level are always displayed as Post Level.

Adjusting the Overall Volume

To adjust the overall volume of the performance, use the MASTER fader or the MONITOR knob.

Adjusting the Volume of an Individual Track

To adjust the volume of an individual track, press [FADER] so that the TR (track) indicator is lit, and use the channel faders.

Adjusting the Headphone Volume

To adjust the volume of the headphones, use the PHONES knob.

Listening to the Demo Song with a Different Arrangement (Scene)

Demo songs contain several completely different sets of settings for pan, playback track, and effects etc. These settings are collectively called a **scene**. By recalling different scenes or changing the scene while you playback a demo song, you can hear the demo song arranged in different ways. Here's how you can listen to various arrangements of the demo.

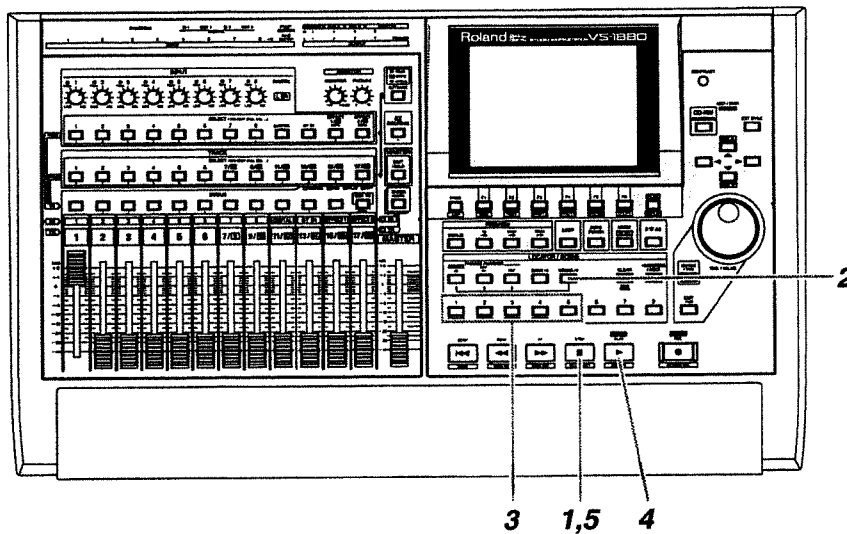

- 1 Press [STOP].
- 2 Press [SCENE]. The button indicator will light.
- 3 Press LOCATOR [2]. Scene two will be loaded.
- 4 Press [PLAY]. The song will playback. Notice that the arrangement of the demo song is different.
- 5 Press [STOP]. Playback will stop.
- 6 Repeat steps 2–5 to hear and compare various arrangements of the demo song.



For details refer to "Using Digital Mixer (Mixer Scenes)" (Owner's manual p.85)



Please stop playback before you switch scenes.

Listening to the Other Demo Song (Song Select)

The VS-1880 contains multiple demo songs. Use the following procedure to select a song.

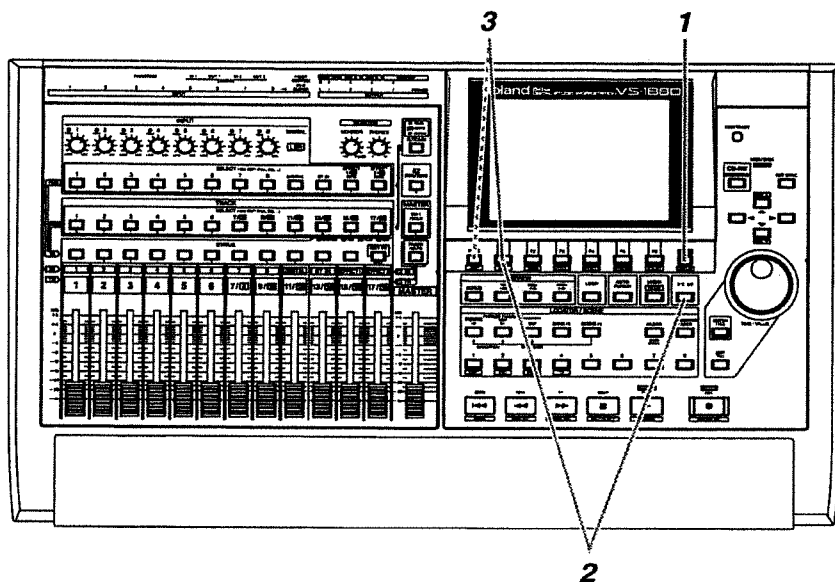

- 1 Press [PLAY (DISPLAY)].
- 2 Hold down [SHIFT] and press [F1 (SONG)]. The Song menu icons will appear.
- 3 Press [F1 (SEL)]. If [F1] does not show "SEL," first press [PAGE] to make the display show "SEL," and then press [F1 (SEL)].

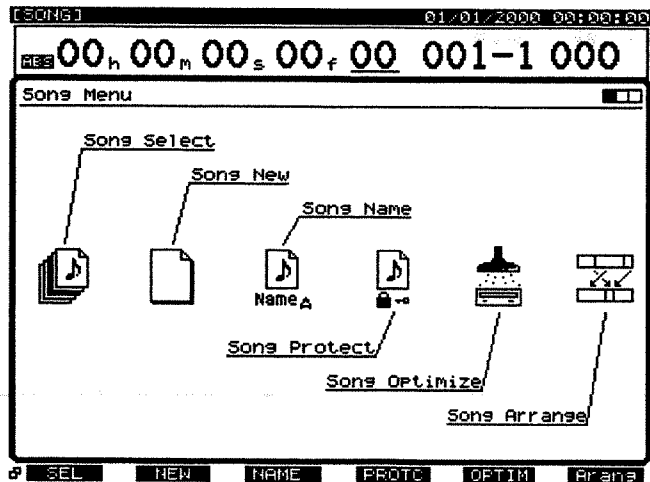

Listening to the Demo Songs

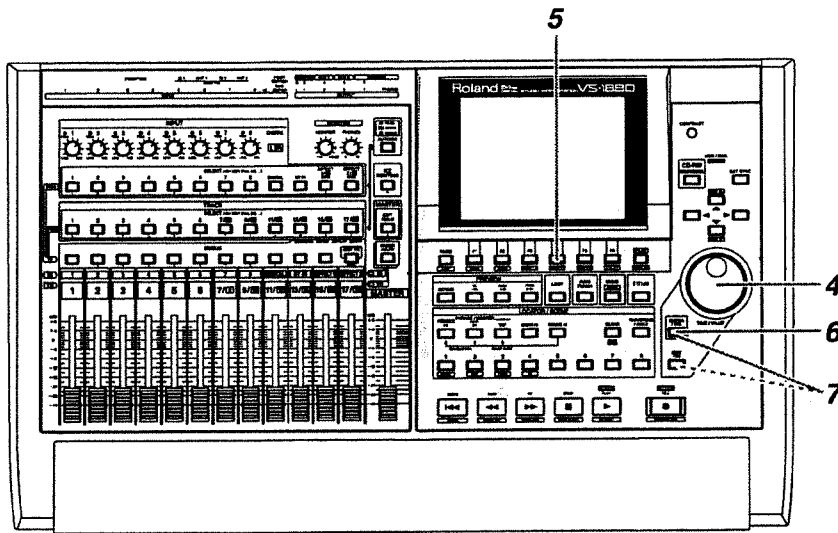

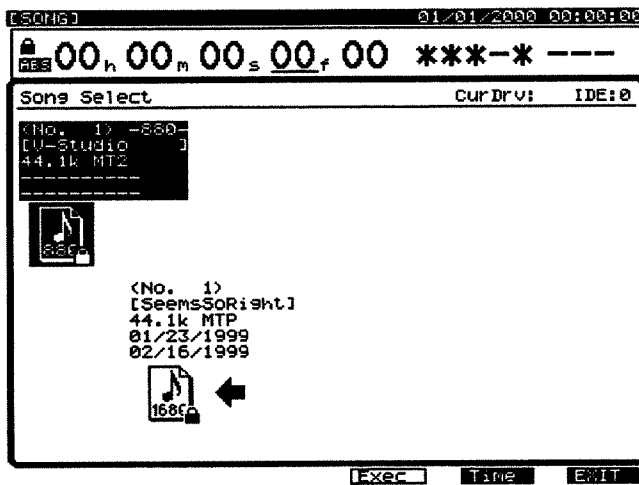

- 4** Use the TIME/VALUE dial to move the cursor to the song that you wish to select.





Different types of songs (for the VS-1680, the VSR-880, the VS-880, and VS-880EX) are distinguished by different icons.

 : for the VS-1680

 : for the VS-880

 : for the VS-1680

 : for the VS-880EX

 : for the VSR-880

- 5** Press [F4 (Exec)]. "Select Song, Sure?" (Are you sure that you want to select this song?) will be displayed.
- 6** Press [YES].
- 7** If the current song is not protected, "STORE Current?" (Store the current song?) will be displayed. If you wish to save the current song, press [YES]. If not, press [NO].
- 8** The song will be selected, and you will return to the previous display. You can playback the demo song as described in "Listening to the Demo Songs" (p. 21) and "Listening to the Demo Song with a Different Arrangement (Scene)" (p. 26).

NOTE

The demo songs are protected so that their content cannot be modified (Song Protect) (Owner's manual p.51). They cannot be recorded, edited, or stored. If a demo song or a song for which Song Protect is turned on has been selected, the "STORE Current?" message will not appear, so you can skip step 7.

Deleting Unneeded Songs (Song Erase)

After creating audio CD's or backing up songs to a Zip disk etc., you may wish to delete unneeded songs from the hard disk. This operation cannot be undone by the Undo function.

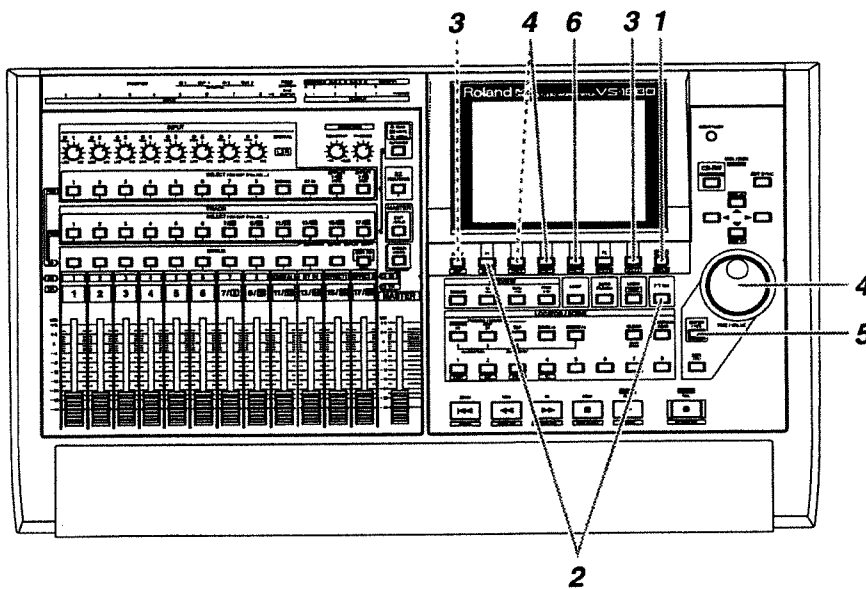

- 1 Press [PLAY (DISPLAY)].
- 2 Hold down [SHIFT] and press [F1 (SONG)]. The Song menu icons will appear.

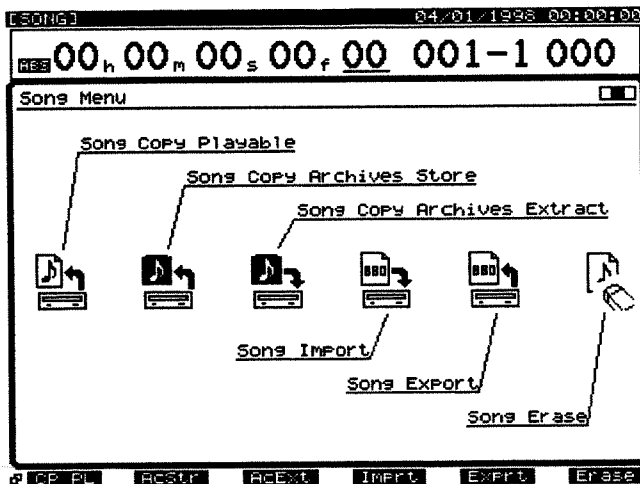

3 Press [F6 (Erase)]. If [F6] does not show "Erase," first press [PAGE] so that "Erase" appears, and then press [F6 (Erase)]. A list of songs will appear.

4 Use the TIME/VALUE dial to move the cursor to the song that you wish to delete, and press [F3 (MARK)]. A mark will be attached to the song (the icon will darken). Each time you press [F3 (MARK)], the mark will appear and disappear. By pressing [F2 (ALL)], you can assign or un-assign all marks simultaneously.

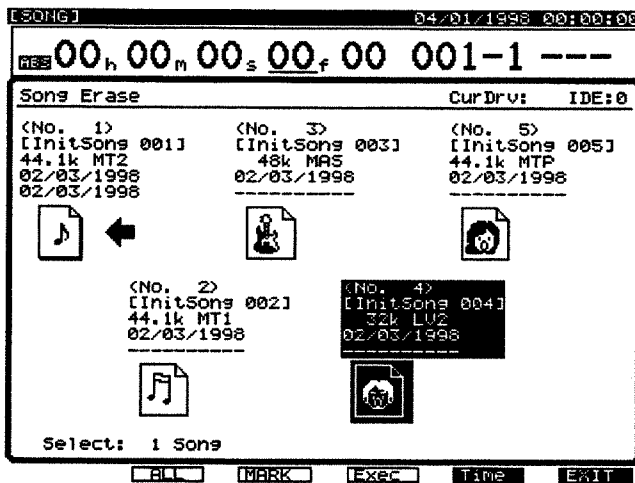

5 You can also erase protected songs (such as the demo songs). If you mark a protected song to be erased, a message will ask you to confirm that you wish to erase the song. If you wish to erase the demo song, press [YES].

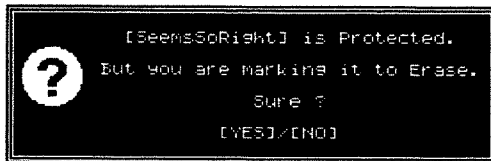

6 Press [F4 (Exec)].

NOTE

If important data is erased by mistake, there is no way to recover it. Roland can take no responsibility of any kind for the recovery of any lost data or any damages incurred thereby.

Listening to the Demo Songs

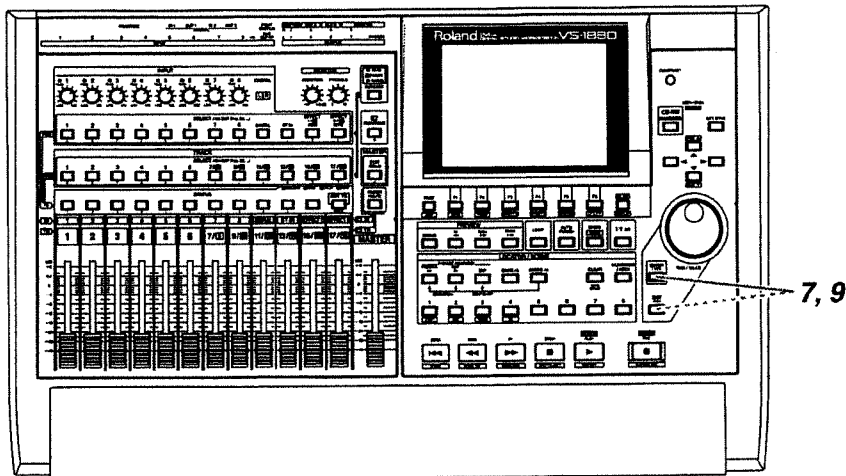

- 7** A message will ask you to confirm. Press [YES] to erase the marked song(s) or, press [NO] to cancel the operation.
- 8** If you are erasing a song other than the current song, the display will ask "STORE Current?" (Store the current song?).
- 9** If you wish to store the current song, press [YES]. If not, press [NO]. If a demo song is selected, press [NO].
- 10** After the song has been erased, the VS-1880 will return to Play condition.

Making a Multi-Track Recording

This chapter explains the basic procedure for recording on the VS-1880. Please follow through these steps to understand the procedure.

Regarding Hard Disk Partition Size

When purchased, the hard disk (HDP-88 series) is divided (partitioned) into 1,000 MB units. If you wish to record for longer times, you can change the partition size to **2,000 MB**. The changed partition size will take effect when you initialize the hard disk (p. 70).

For example, if you change the partition size before you begin the procedures (multitrack recording) described in this chapter, you will be able to record for a longer time. However, **all contents (demo songs) saved on the hard disk will be lost, and cannot be recovered**. As necessary, please back up the demo songs beforehand on an external removable disk or CD-RW disc (VS-1880 Owner's Manual; p.230, p.231).



Recording operations cannot be performed when the demo song is selected. This is because the demo song is protected so that its contents cannot be modified (Song Protect, Owner's Manual p.51). In order to record, use the following procedure to prepare a new song. This is analogous to putting a new tape into a tape-type multi-track recorder.

Creating a New Song (Song New)

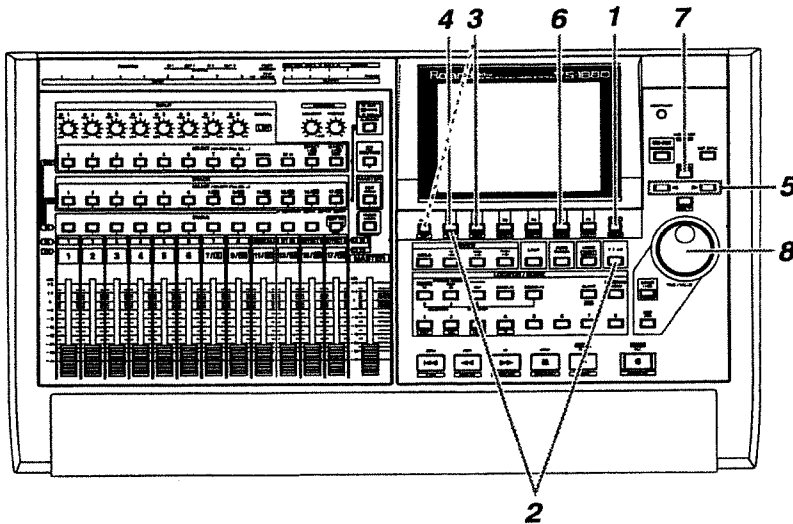

- 1** Press [PLAY (DISPLAY)].
- 2** Hold down [SHIFT] and press [F1 (SONG)]. The Song menu icons will appear.

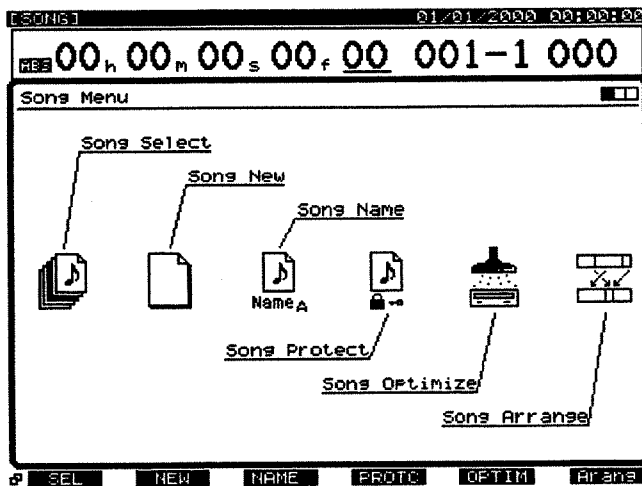

- 3** Press [F2 (NEW)]. If [F2] does not show "NEW," press [PAGE] so that "NEW" appears, and then press [F2 (NEW)]. The Song New display will appear.

Making a Multi-Track Recording

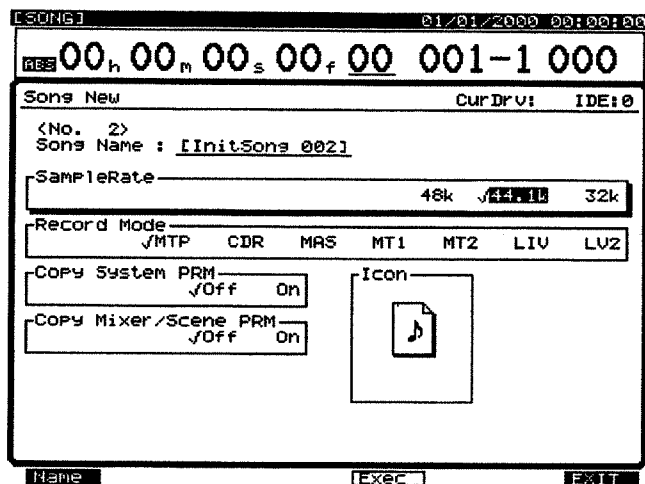

4 Press [F1 (Name)]. The Song Name display will appear.

5 Assign a name to the song. Use [◀] [▶] to highlight the character you wish to change, and rotate the TIME/VALUE dial to select a character.

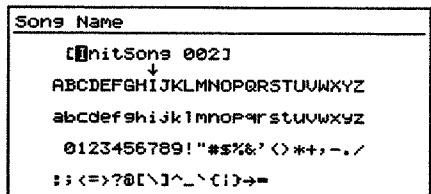

6 After you have assigned the name, press [F5 (Write)].

7 Press [▲] to make the cursor move to "SampleRate."

8 Use the TIME/VALUE dial to select the sample rate for the song (32kHz, 44.1kHz, 48kHz). **If you will be creating an original audio CD, choose "44.1kHz."**

Making a Multi-Track Recording

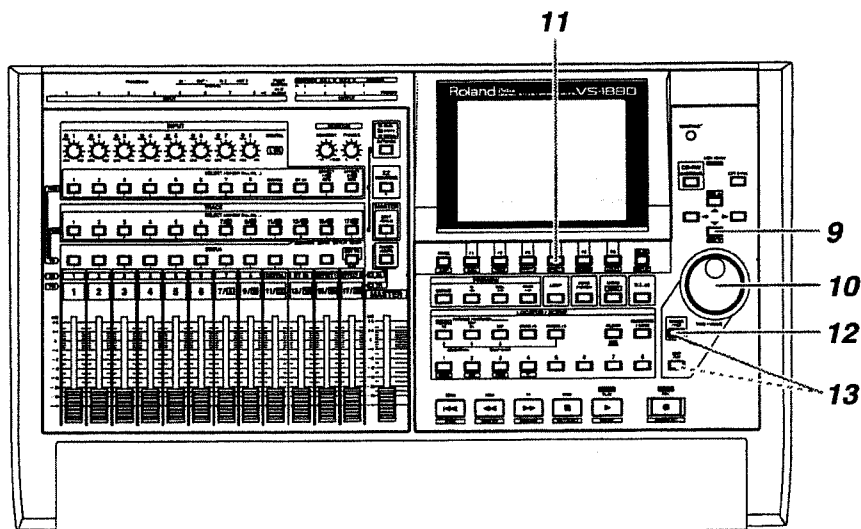

- 9 Press [▼]. The cursor will move to "Record Mode."
- 10 Use the TIME/VALUE dial to select the Recording Mode (MTP, CDR, MAS, MT1, MT2, LIV, LV2). **For the highest recording quality, use the "MTP" recording mode.**
- 11 Press [F4 (Exec)]. "Create New Song, Sure?" (Are you sure that you want to create a new song?) will be displayed.



- 12 Press [YES].

Making a Multi-Track Recording

- 13** If the current song is not protected, "STORE Current?" (Store the current song?) will be displayed. If you wish to store the current song, press [YES]. If not, press [NO].



- 14** The new song will be created, and you will return to the display screen where you began.



The demo songs are protected so that their contents cannot be modified (Song Protect, Owner's Manual p.51). They cannot be recorded, edited, or saved. If a demo song is selected, the "STORE Current?" message will not appear, and step 13 will not be necessary.



For details refer to "Create a New Song (Song New)" (Owner's Manual p.53).

Connecting Microphones

Here we will explain how to connect two microphones and make a multi-track recording. One mic will record an acoustic guitar, and the other mic will record the vocal.

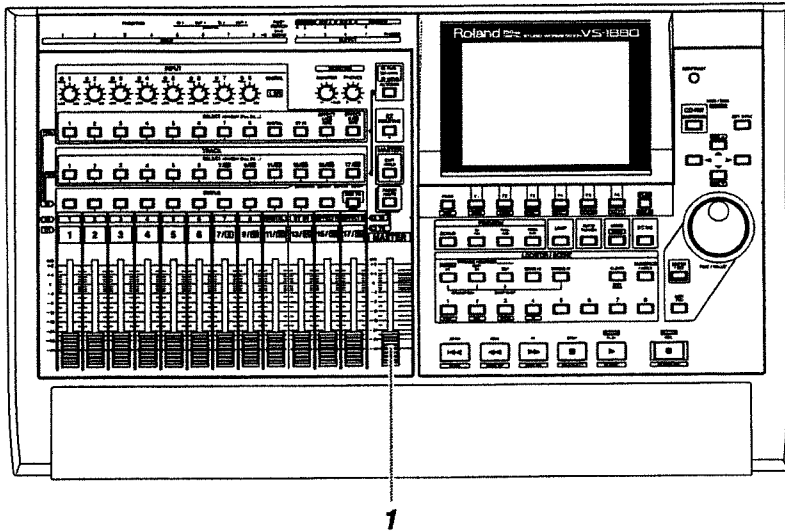

1 Lower the master fader of the VS-1880 to the minimum position.

2 Connect the microphones to the INPUT jacks. A mic with an XLR connector can be connected to INPUT 1 or INPUT 2. A mic with a 1/4 inch phone jack can be connected to the INPUT 3–INPUT 8 jacks.

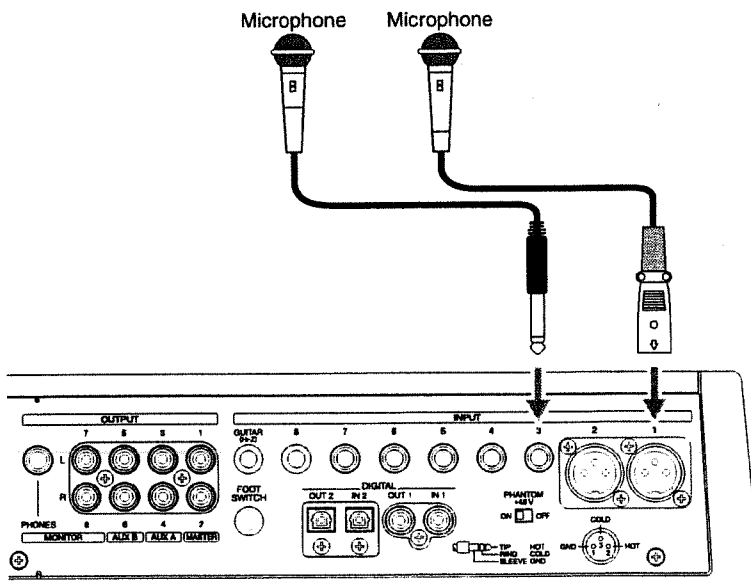

Cautions When Connecting Microphones

- The pin wiring configuration of XLR type connectors is as shown below. Please verify the pin wiring configuration before you connect any device.

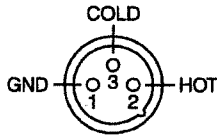

- Depending on the location of a microphone relative to your speakers, acoustic feedback (a whining or shrieking sound) may occur. If this occurs, take the following steps.
 1. Point the microphone in a different direction
 2. Move the microphone away from the speaker
 3. Lower the volume
- The power of the VS-1880 must be turned off before you switch the phantom power on/off. If the phantom power is switched on/off when the VS-1880 is on, a loud noise will be output, which could damage your amp or speakers.
- Carefully read the owner's manual for the microphone you use, and leave the phantom power switched off unless you are connecting a condenser mic that requires a phantom power supply. If phantom power is supplied to a dynamic mic or audio playback device, malfunctions may result.

?
Phantom Power
(Appendices p.13)

Adjusting the Input Sensitivity

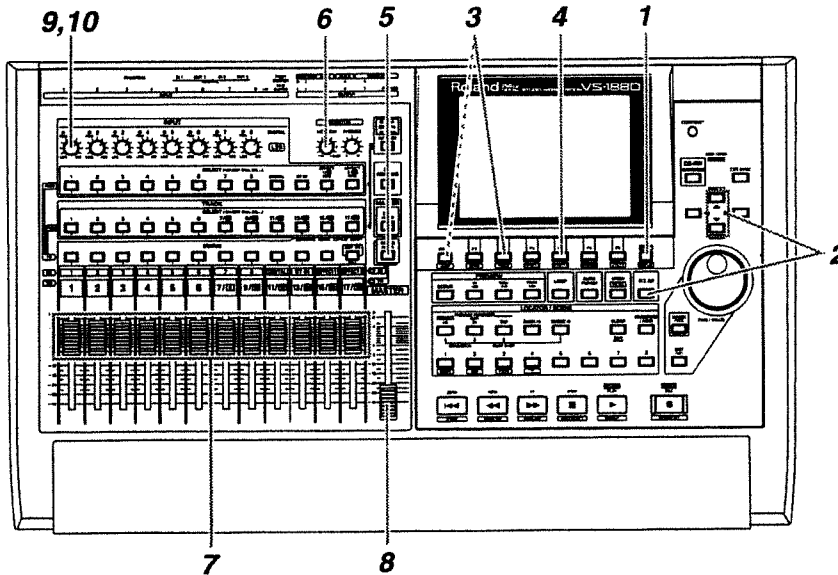

- 1 Press [PLAY (DISPLAY)].
- 2 Hold down [SHIFT] and press [▲] or [▼] so that the center section of the display is enclosed in a bold frame.
- 3 Press [F2 (LM In)]. If [F2] does not show "LM In," first press [PAGE] so that "LM In" appears, and then press [F2 (LM In)]. Now the level meters will show the volume level of the input source.

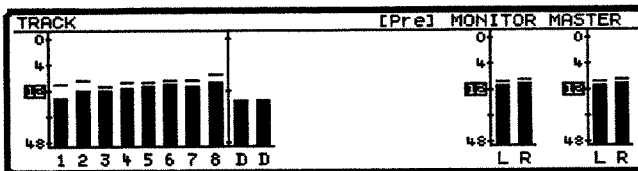

- 4 Make sure that the lower left of the center line of the display indicates "Pre." If it indicates "Pst," press [F4 (→PRE)]. The volume levels before passing through the channel fader (Pre Level) will be displayed.

- 5** Press [FADER] so that the IN (input) indicator is lit.
- 6** Set the MONITOR knob to the 0 dB position (3 o'clock).
- 7** Set all channel faders to the 0 dB position.
- 8** Raise the master fader to an appropriate level.
- 9** While singing or playing into the mic, gradually raise the INPUT knob for the jack to which the mic is connected. For example if the mic is connected to INPUT 1, play your guitar or sing while you adjust the INPUT 1 knob.
- 10** Notice that the level meter moves, and that sound is output. Set the INPUT knob as high as possible while keeping the PEAK indicator from lighting. Generally, the INPUT knob should be at about 3 o'clock. Ideally, the level meter should be moving in the range of -12 to 0 dB in order to record with the optimal audio quality.

Connecting an Instrument Other than a Microphone

- If you wish to connect an electronic musical instrument (synthesizer etc.), connect it to any of the INPUT 3–INPUT 8 jacks. In this case, you will generally set the INPUT knob in the 9 o'clock region.
- If you are connecting an electric guitar or electric bass directly, connect it to the GUITAR (Hi-Z) jack by the INPUT 8. In this case, you will generally set the INPUT 8 knob in the 9 o'clock region.
- It is not possible to use both the INPUT 8 jack and the GUITAR (Hi-Z) jack simultaneously. If a plug is inserted into both jacks, the GUITAR (Hi-Z) jack will take priority. If you wish to use the INPUT 8 jack, do not connect anything to the GUITAR (Hi-Z) jack.

MEMO

Use these channel faders to adjust the volume level that will be sent to Master Out by each input channel. Furthermore, When an input channel is assigned to a track, the corresponding channel fader will adjust the recording level to the applicable track.

MEMO

The INPUT knobs adjust the input sensitivity, so that the analog input to each input channel will be at an appropriate level.

Making a Multi-Track Recording

Recording On a Track

This section explains the procedure for using a mic connected to the INPUT1 jack to record an acoustic guitar performance to track 1.

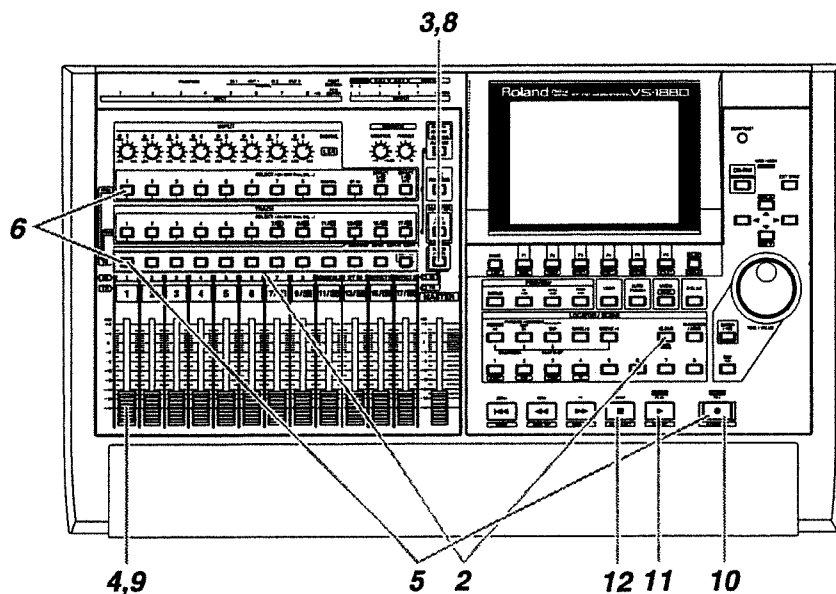

- 1 Press [PLAY (DISPLAY)].
- 2 Hold down [STATUS] (any track is OK) and press [CLEAR].
- 3 Press [FADER] so that the IN (input) indicator is lit.
- 4 Raise and lower channel fader 1, and verify that the volume changes. The input channel fader is used to make fine adjustments to the recording level. In order to record with the optimal audio quality, you should normally set the fader at 0 dB.
- 5 Select the recording track. Hold down [REC] and press the [STATUS] button of the desired track. For this example, hold down [REC] and press the track 1 [STATUS] button. [STATUS] will blink red. (ready to record)

MEMO

This will clear any existing input and/or track routing assignments.

Making a Multi-Track Recording

6 Select the source that will be recorded to the track. Hold down the [STATUS] button of the track you wish to record, and press the [SELECT] button of the input channel that you wish to assign as the source. For this example, hold down track 1 [STATUS] and press input channel 1 [SELECT]. [SELECT] so that it blinks.

MEMO

At this time, the sound of input channel 1 will no longer be output directly from master out.

7 If you continue holding [STATUS] for a short time longer, you can check which source is assigned to each track.

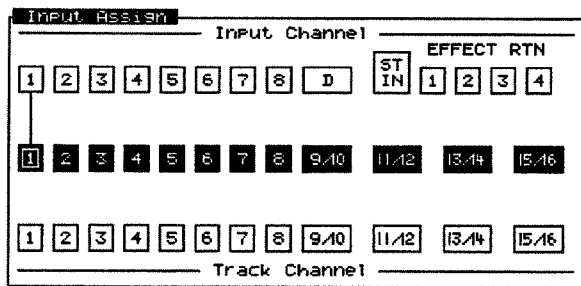

8 Press [FADER] so that the TR (track) indicator lights.

9 Raise and lower channel fader 1 to verify that the volume changes. The track channel fader is used for monitoring. It does not affect the recording level. Even if you hear no sound, you can still record. Adjust the volume to a suitable level for listening.

10 Press [REC]. The [REC] indicator will blink red.

11 Press [PLAY]. The [PLAY] indicator will light green, and recording will begin. Start playing your acoustic guitar.

12 When you finish playing, press [STOP].

13 For each track whose [STATUS] is blinking red, press the [STATUS] button several times to make it light green. For this example, press the [STATUS] button for track 1 until it lights green.

Playing Back the Performance You Recorded

Now let's playback the performance that was recorded on track 1.

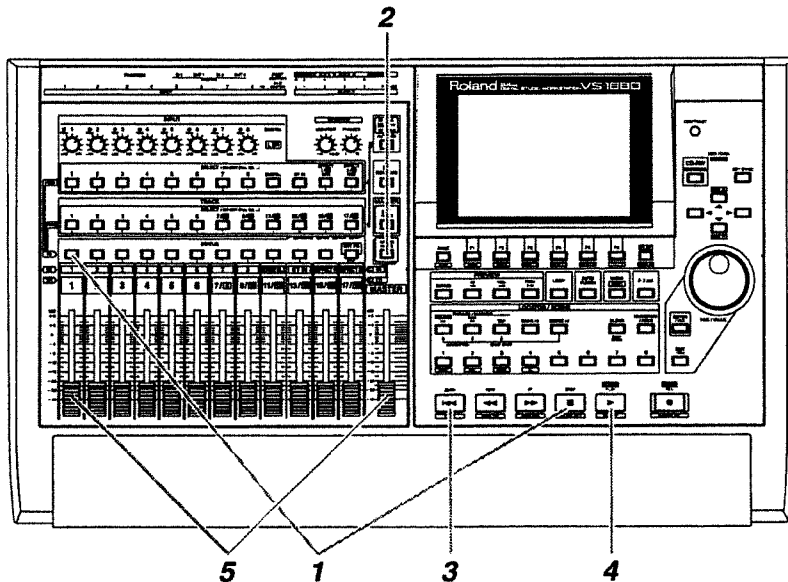

- 1** Hold down [STOP] and press the track 1 [STATUS] button. [STATUS] will light green.
- 2** Press [FADER] so that the TR (track) indicator is lit.
- 3** Press [ZERO]. You will return to the beginning of the song.
- 4** Press [PLAY]. The song will play back.
- 5** Use channel fader 1 and the master fader to adjust the volume to a comfortable level.

Canceling the Recording

Checking the Time Available for Recording (Remaining Time)

Each time a performance is recorded on a track, hard disk capacity will be used up, and the remaining time available for recording will decrease. You may continue recording as long as there is sufficient capacity on the hard disk. When you would like to know how much recording time is left, you can use the following procedure. It is a good idea to check the remaining recording time before you start recording.

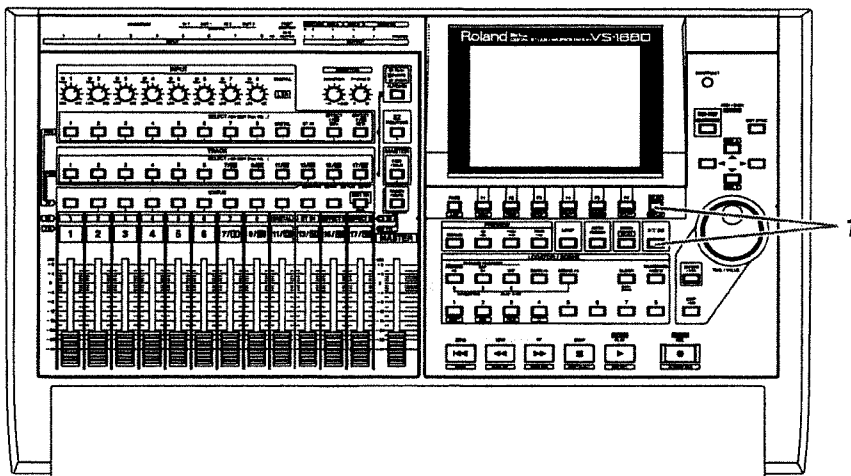

- 1** Hold down [SHIFT] and press [PLAY (DISPLAY)] several times so that the name of the current song is displayed. At this time, the level meters will not be displayed.

Making a Multi-Track Recording

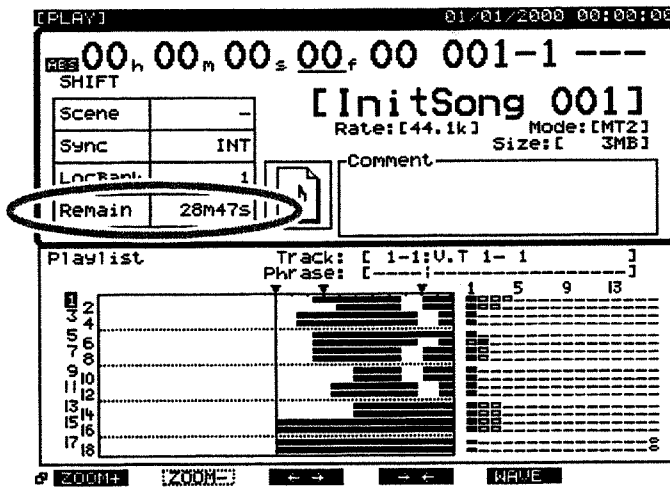
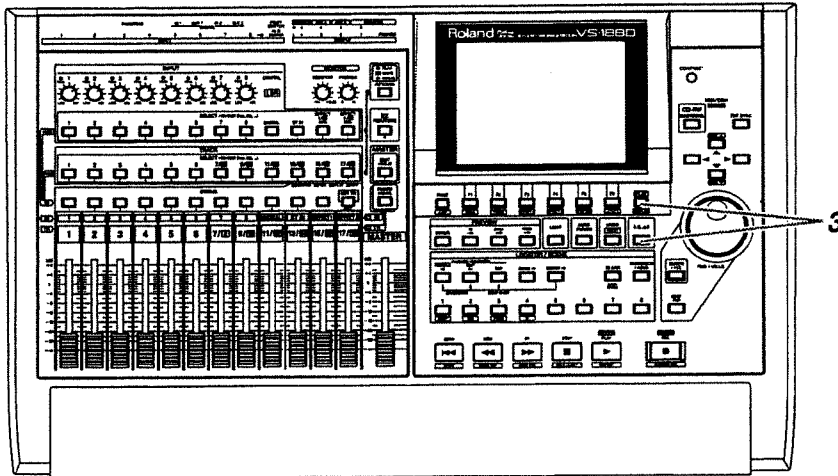

2 The amount of available time on the hard disk drive will be displayed next to “Remain” in the upper section of the display (in this example there are 28 minutes and 47 seconds of recording time available).

3 Hold down [SHIFT] and press [PLAY (DISPLAY)] until the level meter or fader/pan display appears.

MEMO

The available recording time will depend on the number of [STATUS] indicators that are either blinking red (ready to record) or lit red (recording). This display indicates the remaining length of time that can be recorded.



For details refer to “Checking Remaining Space” (Owner’s Manual p.218).

Canceling a Recorded Result (Undo/Redo)

If the recording level was too low, if you made a mistake in your performance, or if for any other reason you wish to re-do the recording, you can use the following procedure to cancel the contents of the recording. This is called the **Undo function**. You can also cancel the previously-executed Undo to return to the original state, and this is called the **Redo function**.



When you execute Undo, the recorded data will appear to have disappeared. However, the data that is no longer played back will not be erased from the hard disk until you save that song (p. 69). For this reason, executing Undo will not increase the available

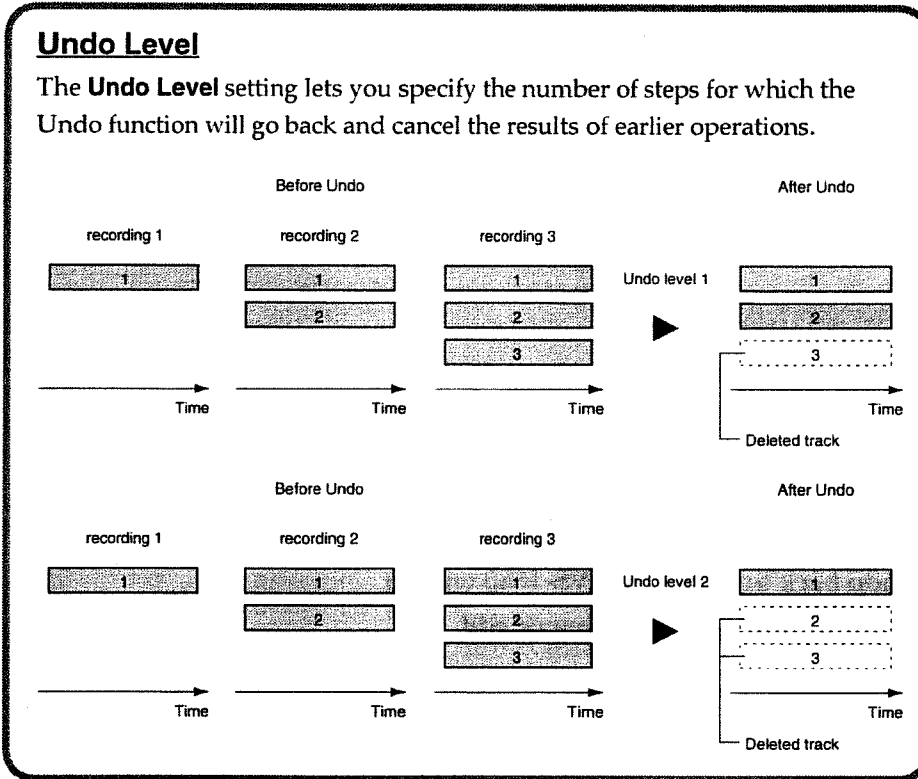

Making a Multi-Track Recording

Undo

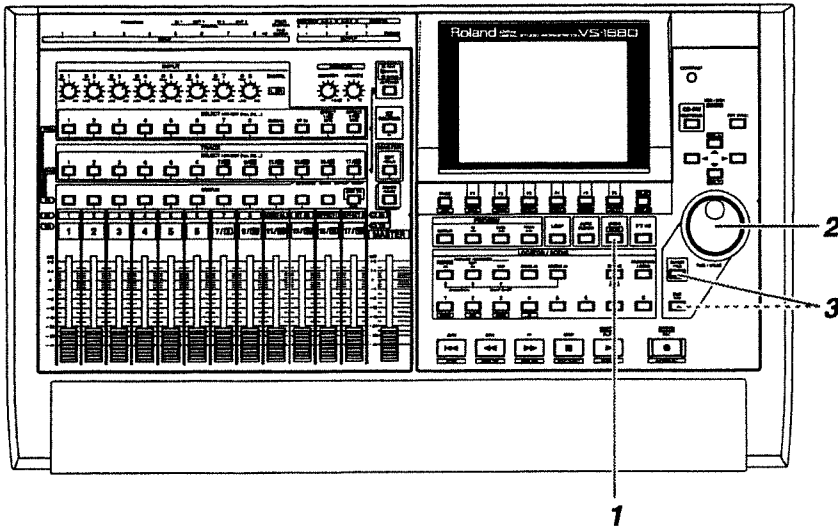

1 Press [UNDO].

2 The display will indicate "UNDO Level=." Use the TIME/VALUE dial to specify how many steps you wish to return. For example, if you Undo back to level 1, the VS-1880 will be restored to the point prior to your last recording or edit.

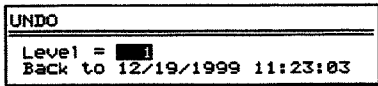

3 Press [YES]. The [UNDO] indicator will light to show that the Undo operation has been executed successfully. If you decide not to execute Undo, press [NO].

Redo

If you wish to cancel the last-executed Undo (i.e., if you wish to return to the original state), use the following procedure.

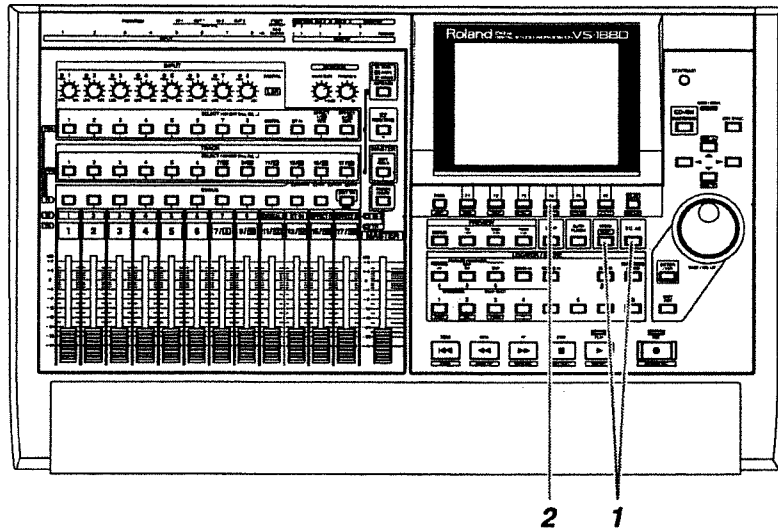

- 1** Make sure that [UNDO] is lit. Then hold down [SHIFT] and press [UNDO].
- 2** The display will ask "Cancel the last UNDO ?" Press [F4 (Exec)].



Redo allows you to change your mind about your most recent Undo, allowing you to go back to having the change put into effect, thus "redoing" it.

Note, for example, that if you've carried out Undo two times in a row, by using Redo, you're returned to the state in effect immediately before you ran Undo for the second time.



If you save the song after executing Undo, it will no longer be possible to perform Redo (p. 69).



For details refer to "To use the Undo Function" (Owner's Manual p.65)
To cancel just the previous recording, refer to "To Cancel an Undo (Redo)" (Owner's Manual p.65)

Making a Multi-Track Recording

Re-Recording a Specified Portion (Punch-In/Punch-Out)

When you listen to a performance that you recorded, you may notice that even though the overall performance is good, a mistake was made or the wrong lyrics were sung in just one location. In such cases you can use the following procedure to re-record just the portion in which the mistake occurred. This is called **Punch-in/Punch-out**.

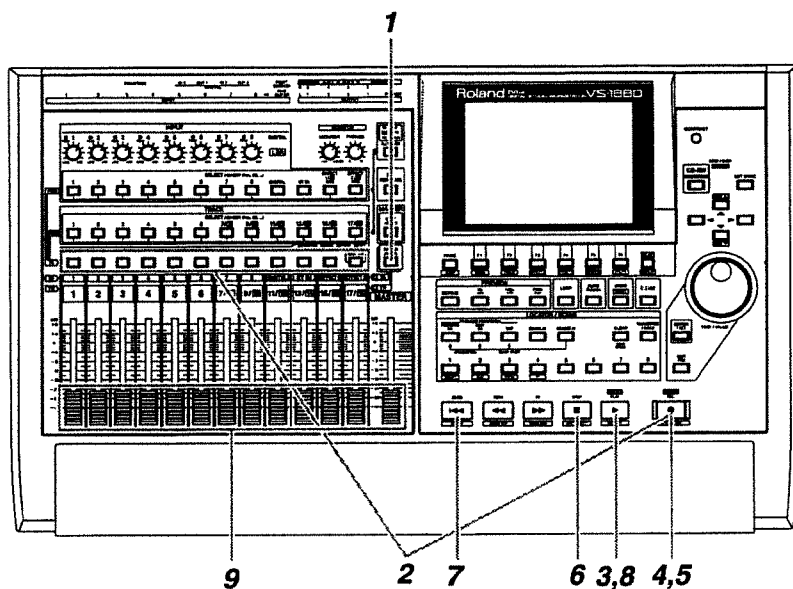

- 1** Press [FADER] so that the TR (track) indicator is lit.
- 2** Hold down [REC] and press the [STATUS] button of the track that you wish to re-record. [STATUS] will blink red.
- 3** Press [PLAY]. The song will play back.

Punch-In Recording

When you perform punch-in recording, you must make sure that the previously-recorded track and the source now being recorded are at the same volume. During playback, you can alternately monitor the track and the source by pressing the [STATUS] button of the track that you wish to re-record.

Compare the sounds to make sure that there is no difference in level between them. If necessary, use the INPUT knob to adjust the input sensitivity (p. 40) or the input channel fader to adjust the recording level (p. 42).

NOTE

Although it will appear that the audio data is overwritten by this process, the data that is no longer played back is not actually erased from the hard disk. This means that the available recording time will decrease when you punch-in/punch-out. If you wish to increase the available recording time, please read "Deleting an Erased Recording from the Disk (Song Optimize)" (p. 55).

Making a Multi-Track Recording

- 4** At the point where you wish to begin re-recording, press [REC]. [REC] will light red, indicating that recording is occurring. Begin playing or singing.
- 5** When you finish playing or singing, press [REC] once again. [REC] will go dark, indicating that you have returned to playback mode.
- 6** Press [STOP]. The song will stop.
- 7** To listen to your recording, press [ZERO]. You will return to the beginning of the song.
- 8** Press [PLAY]. The song will play back.
- 9** Use the channel faders and master fader to adjust the volume to a comfortable level.



For details refer to
"Recording Over a Portion
of a Performance (Manual
Punch-In/Punch-Out)"
(Owner's Manual p.60)
To punch-in/punch-out
automatically, refer to
"Specifying Beforehand the
Location for Recording
(Auto Punch-In and Punch-
Out)" (Owner's Manual
p.61)
To repeatedly record the
same area, refer to "Loop
Recording" (Owner's
Manual p.63)

Making a Multi-Track Recording

Erasing Just a Portion of a Recording (Track Erase)

If instead of re-recording the portion where a mistake was made, you simply wish to erase the mistake, use the following procedure. The result will sound the same as recording silence over the unwanted section, without using additional disk space.

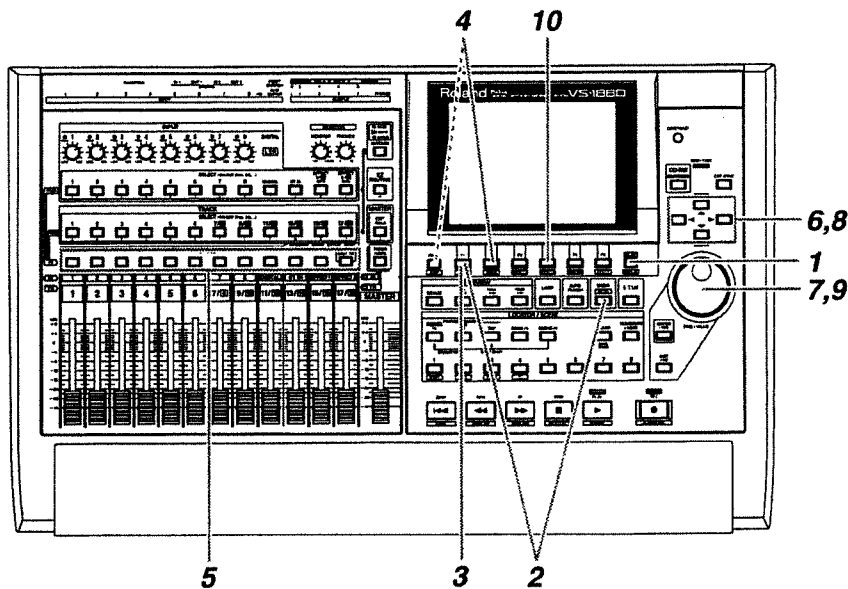

NOTE

Although it will appear that the audio data is erased by this process, the data that is no longer played back is not actually erased from the hard disk. This means that the available recording time will not increase when you use the Track Erase operation. If you wish to increase the available recording time, please read "Deleting an Erased Recording from the Disk (Song Optimize)" (p. 55).

- 1** Press [PLAY (DISPLAY)].
- 2** Hold down [SHIFT] and press [F2 (TRACK)].
- 3** Press [F1 (Tr/Ph)] to access the Track Edit menu.
- 4** Press [F2 (Erase)]. If [F2] does not show "Erase," first press [PAGE] so that "Erase" appears, and then press [F2 (Erase)].

Making a Multi-Track Recording

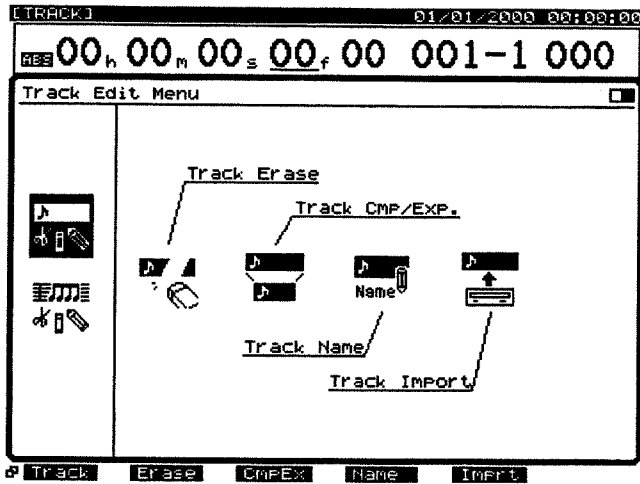

- 5 Press [STATUS] for the track that you wish to erase. [STATUS] will light red.
- 6 Use [▲][▼][◀][▶] to move the cursor to "START."
- 7 Use the TIME/VALUE dial to specify the starting time of the area that you wish to erase.
- 8 Use [▲][▼][◀][▶] to move the cursor to "END."
- 9 Use the TIME/VALUE dial to specify the ending time of the area that you wish to erase.

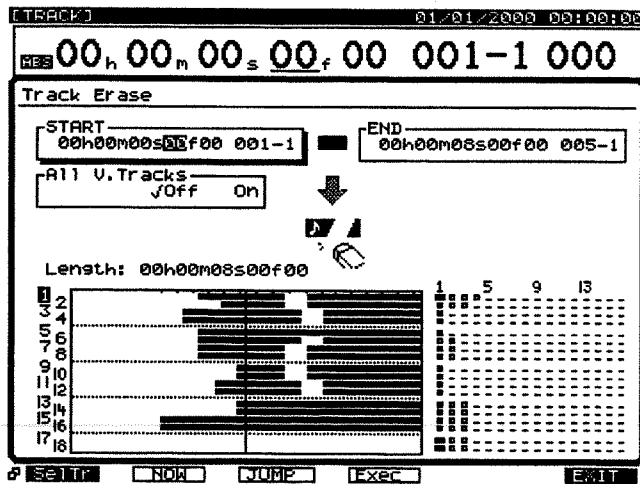

- 10 Press [F4 (Exec)]. The Track Erase operation will be executed.

MEMO

You can press [▼] to move the cursor from "START" to "END."

MEMO

About [F2 (NOW)] and [F3 (JUMP)] buttons.

NOW:

You can set the present time to the START or END time. If you want to set the present time at the beginning time of a range you want to delete, then make sure the cursor is at "START," and press [F2 (NOW)].

JUMP:

You can shift the present time to the time set for START or END. To shift the present time to the end time of the range you want to delete, make sure the cursor is at "END," then press [F3 (JUMP)].

Making a Multi-Track Recording

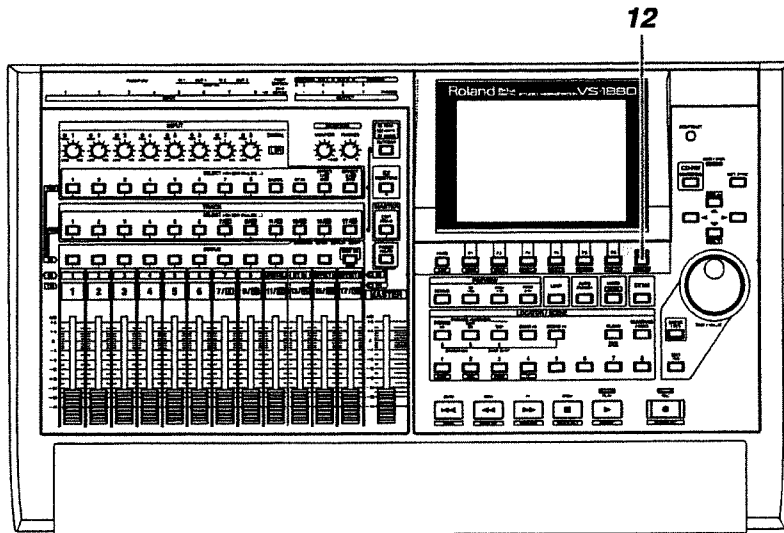

- 11** When the operation has been completed successfully, the display will indicate "Complete."
- 12** Press [PLAY (DISPLAY)] to return to the original display screen.



For details refer to "Track Erase" (Owner's Manual p.143).

Deleting an Erased Recording from the Disk (Song Optimize)

When you perform punch-in recording or use operations such as Track Erase, the data that is no longer played back will remain on the disk drive without being actually deleted. The **Song Optimize** operation deletes this unneeded data from the hard disk, in order to increase the available space (recordable time) on the hard disk. This operation cannot be undone by the Undo function. Furthermore, recorded data that was deleted by the Song Optimize operation cannot be recovered.

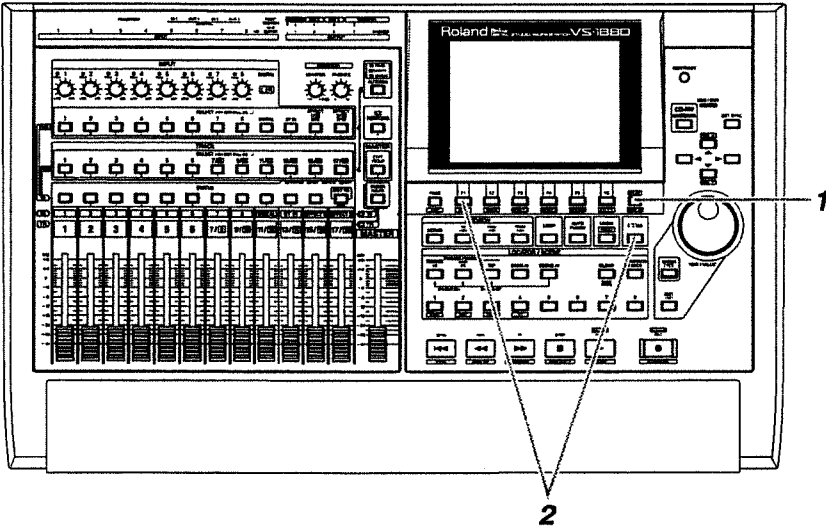

- 1 Press [PLAY (DISPLAY)].
- 2 Hold down [SHIFT] and press [F1 (SONG)]. The Song menu icons will appear.

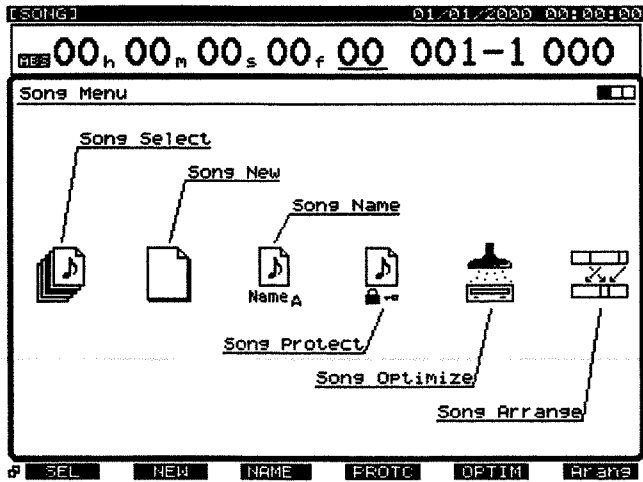

Making a Multi-Track Recording

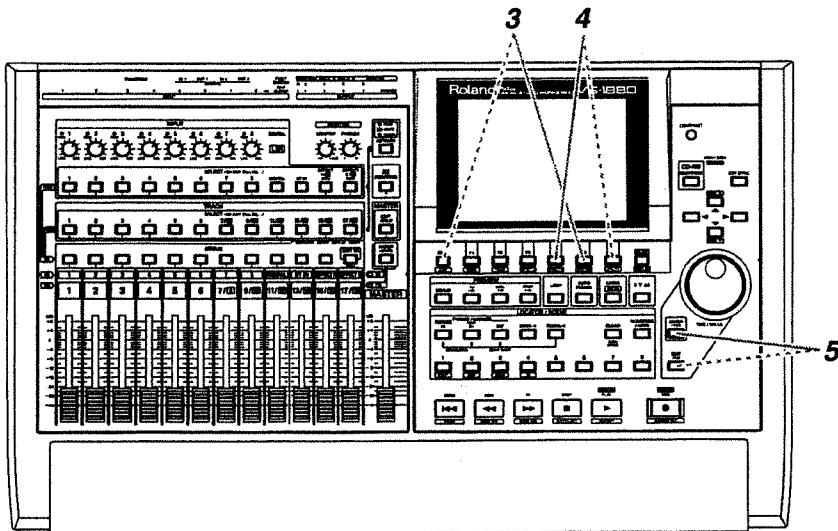

- 3 Press [F5 (OPTIM)]. If [F5] does not indicate "OPTIM," first press [PAGE] so that "OPTIM" is displayed, and then press [F5 (OPTIM)].
- 4 "Song Optimize, Execute ?" (execute the Song Optimize operation?) will be displayed. Press [F4 (Exec)]. If you decide not to execute the operation, press [F6 (EXIT)].
- 5 A message will ask you to confirm. Press [YES]. If you decide not to execute, press [NO].

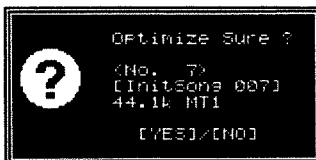

- 6 "Optimize Really Sure ?" will be displayed. Press [YES] to execute the Optimize operation. If you decide not to execute, press [NO].
- 7 When the Optimize operation is completed, you will return to the display where you began.

NOTE

Depending on the situation, it may take some time for the Optimize operation to be completed. This is not a malfunction. Do not turn off the power until Optimize has been completed.



For details refer to "Song Optimize" (Owner's Manual p.218)

Recording On a V-Track

The VS-1880 has 18 tracks, and each of these tracks has 16 supplementary tracks called **V-tracks**. By using these V-tracks you can record up to 288 (18 x 16) tracks of audio.

The following example shows how to record a performance on V-track 2 of track 1.

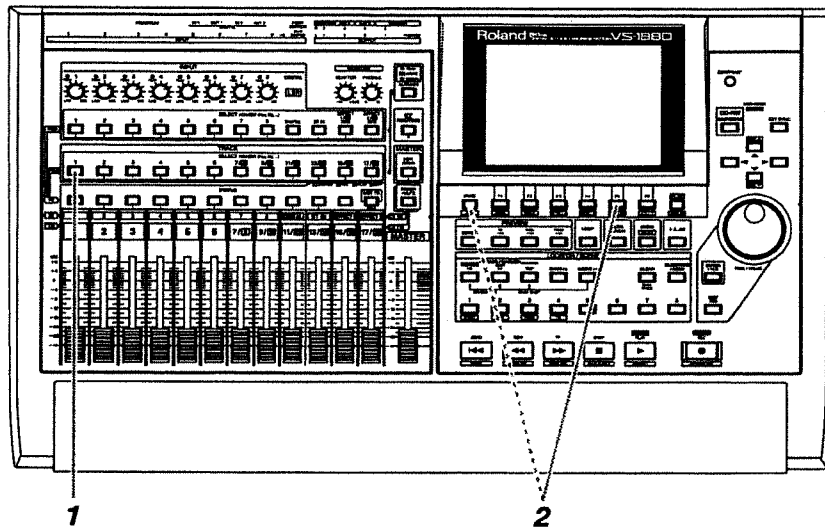

- 1** Press the track channel 1 [SELECT] button. [SELECT] will light, and the Track Mixer display will appear.
- 2** Press [F5 (V.Trk)]. If [F5] does not show "V.Trk," first press [PAGE] so that "V.Trk" appears, and then press [F5 (V.Trk)].

Making a Multi-Track Recording

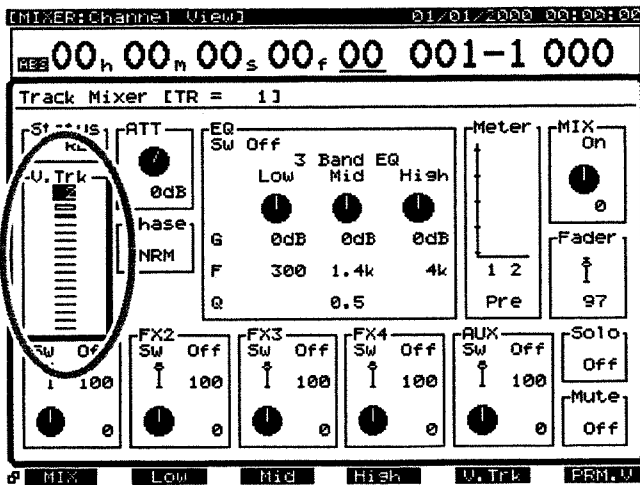
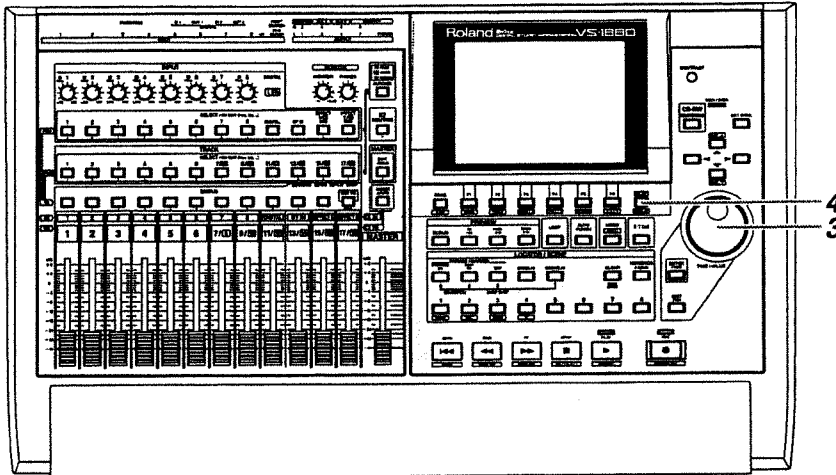

- 3 Use the TIME/VALUE dial to select the V-track that will be used for recording/playback. For this example select "2."
- 4 Press [PLAY (DISPLAY)] to return to the original display screen.
- 5 Now you will be able to record on V-track 2 of track 1. As described in "Recording On a Track" (p. 42), record your performance and listen to it.



For details refer to "Auxiliary Tracks for Each Track" (Owner's Manual p.35).

Comparing the Recorded Content of Two V-Tracks

If you have been following the procedures in the previous examples, V-tracks 1 and 2 of track 1 contain recorded performances. Here's how you can compare the performances of the two V-tracks.

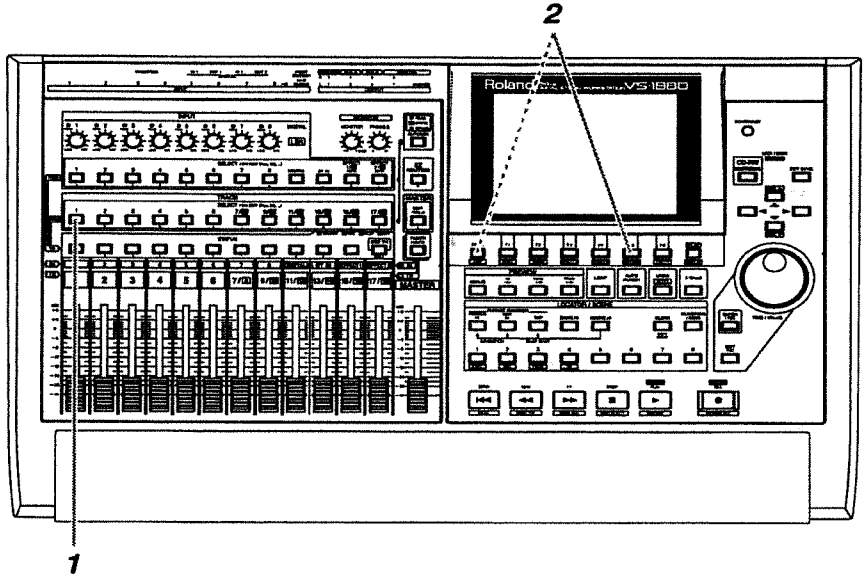

- 1** Press the track channel 1 [SELECT] button. [SELECT] will light, and the Track Mixer display will appear.
- 2** Press [F5 (V.Trk)]. If [F5] does not show "V.Trk," first press [PAGE] so that "V.Trk" appears, and then press [F5 (V.Trk)].

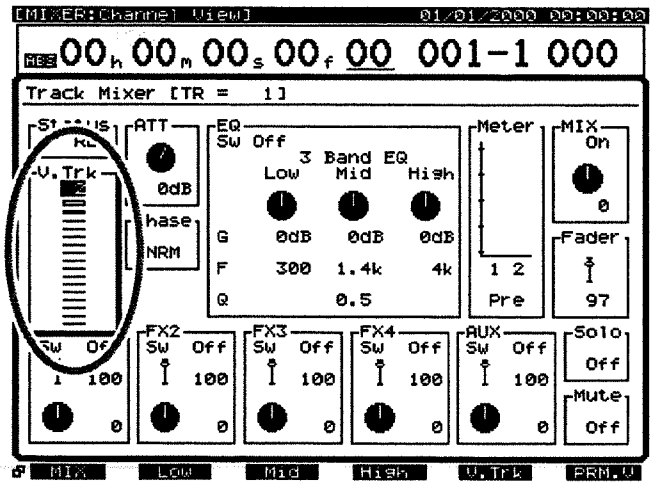

Making a Multi-Track Recording

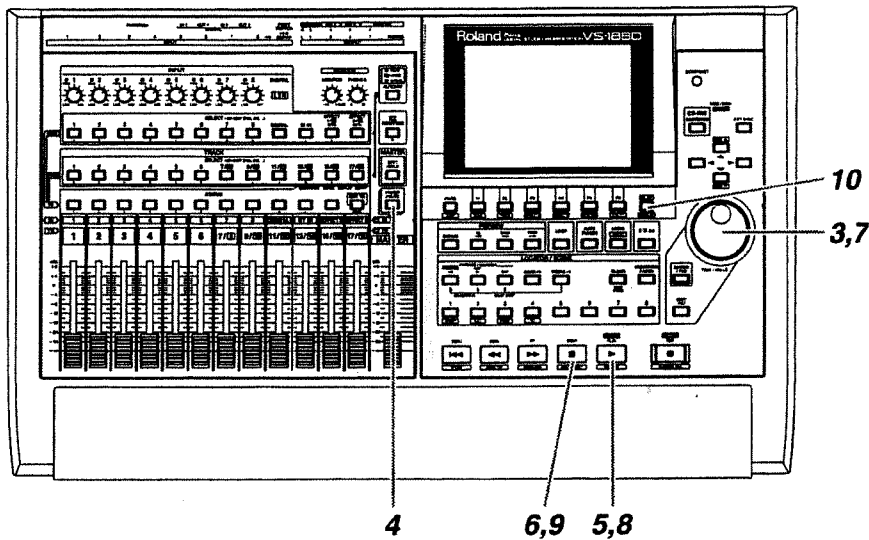

- 3** Use the TIME/VALUE dial to select V-track 1.
- 4** Press [FADER] so that the TR (track) indicator is lit.
- 5** Press [PLAY]. Playback will begin.
- 6** Press [STOP].
- 7** Use the TIME/VALUE dial to select V-track 2.
- 8** Press [PLAY]. Notice that a different performance is played back.
- 9** Press [STOP].
- 10** Press [PLAY (DISPLAY)] to return to the original display screen.

NOTE

It is not possible to change V-tracks while the song is playing.

Recording On Other Tracks

The VS-1880 allows you to record new performances on other tracks while you listen to the playback of previously recorded tracks. This process is called **Overdubbing**. In the following example we will explain how to use a mic connected to the INPUT 2 jack to record a vocal on track 3 while you listen to the acoustic guitar performance that you recorded earlier on track 1. As described in "Adjusting the Input Sensitivity" (p. 40), adjust the input sensitivity of the mic connected to the INPUT 2 jack before you begin.

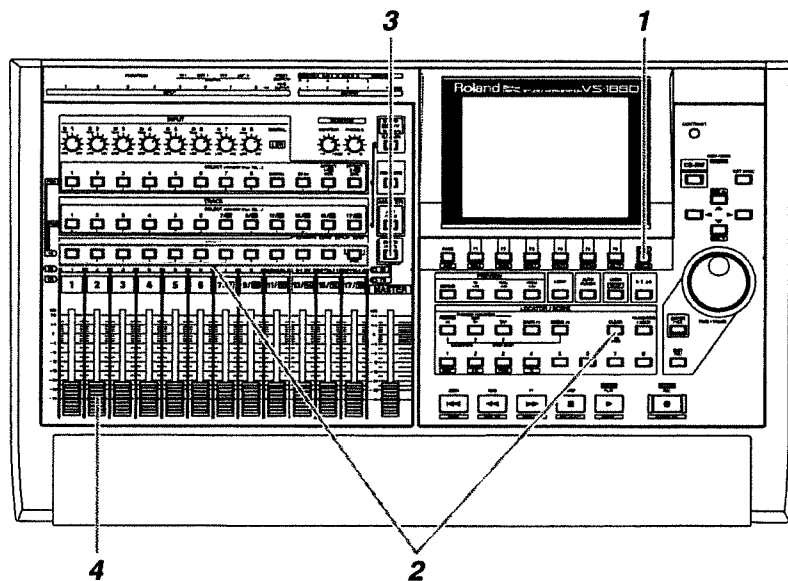

- 1 Press [PLAY (DISPLAY)].
- 2 Hold down [STATUS] (of any track) and press [CLEAR].
- 3 Press [FADER] so that the IN (input) indicator is lit.
- 4 While you sing into the mic, raise and lower channel fader 2 to verify that the volume changes. The channel fader is used to make fine adjustments to the recording level. In order to record with optimal audio quality, the channel fader should normally be in the position of 0 dB.



The assignments of input sources to tracks will be cleared.

Making a Multi-Track Recording

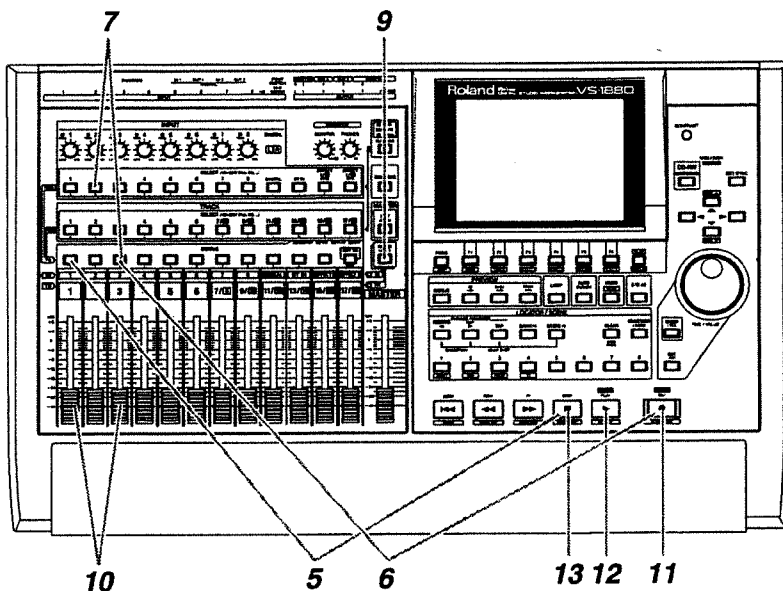

5 Select the playback track(s). Hold down [STOP], and press the [STATUS] button of the track(s) that you wish to hear. For this example, hold down [STOP] and press the track 1 [STATUS] button. [STATUS] will light green.

6 Select the track(s) for recording. Hold down [REC] and press the [STATUS] button of the track(s) that you wish to record. For this example, hold down [REC] and press the track 3 [STATUS] button. [STATUS] will blink red.

7 Select the source that will be recorded on the track. Hold down the [STATUS] button of the track that you wish to record, and press the [SELECT] button of the input channel that you wish to assign. For this example, hold down the track 3 [STATUS] button, and press the input channel 2 [SELECT] button. [SELECT] will blink.

8 By continuing to hold down [STATUS] for a time, you can check which source is assigned to which track.

MEMO

At this time, the sound of input channel 2 will no longer be output directly from master out.

Making a Multi-Track Recording

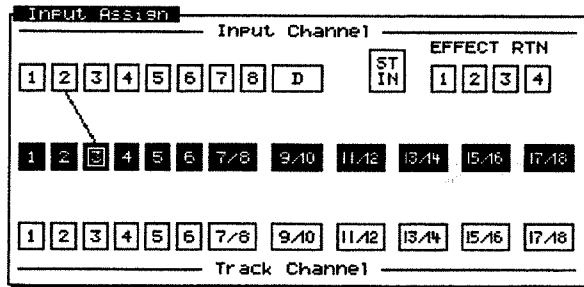

- 9** Press [FADER] so that the TR (track) indicator is lit.
- 10** Raise and lower channel fader 3 to hear the volume change. The track channel fader is used for monitoring. It does not affect the recording level. You will be able to record even if you don't hear any sound. Adjust the level to a comfortable monitoring volume. You can use channel fader 1 to adjust the volume of the playback track.
- 11** Press [REC]. The [REC] indicator will blink red.
- 12** Press [PLAY]. The [PLAY] indicator will light green, and recording will begin.
- 13** When you finish recording, press [STOP].
- 14** For each track whose [STATUS] is blinking red, press the [STATUS] button several times to make it light green.

Playing Back Two or More Tracks

Adjust the Volume Balance of the Tracks

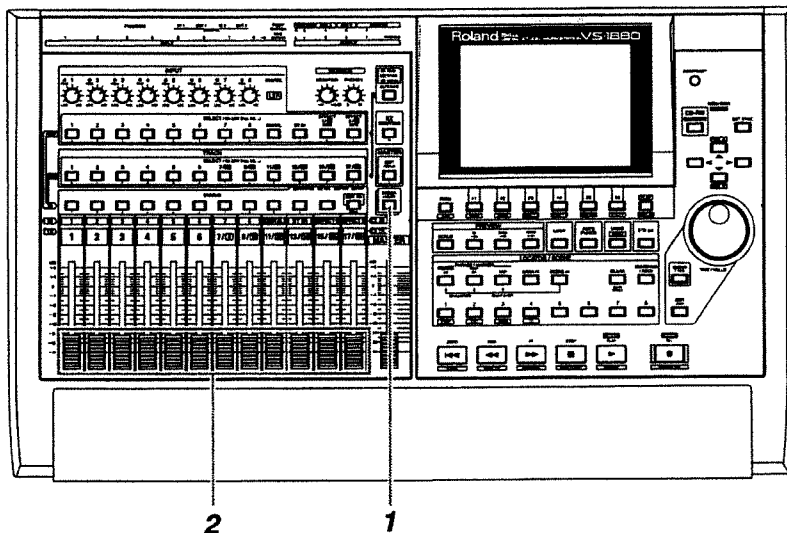

- 1** Press [FADER] so that the TR (track) indicator is lit.
- 2** Use the channel fader of each track to adjust the volume balance of the tracks.

Adjusting the Stereo Position of Each Track

The VS-1880 does not have Pan knobs. If you wish to adjust the stereo position (pan) of each track, use the following procedure.

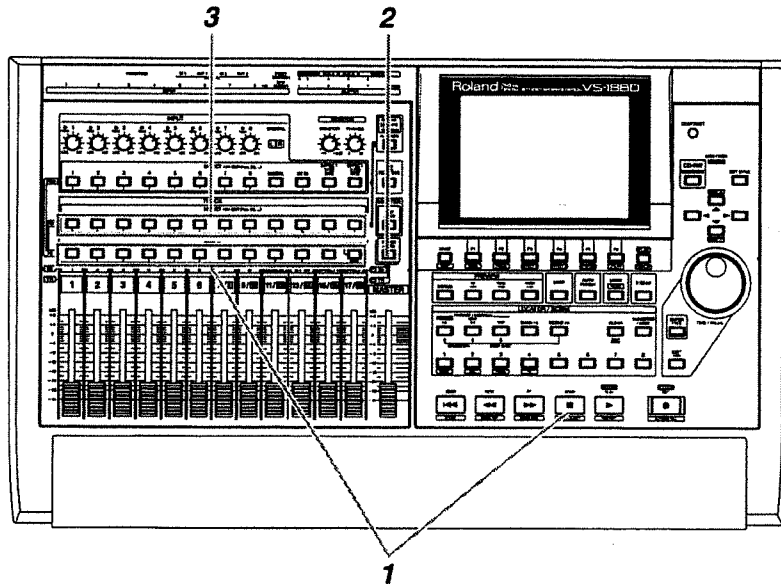

- 1** Hold down [STOP], and press the [STATUS] button for the track whose pan you wish to adjust so that the [STATUS] indicator is lit green.
- 2** Press [FADER] so that the TR (track) indicator is lit.
- 3** Decide on the track whose pan setting you wish to adjust, and press the [SELECT (CH EDIT)] button for that track channel. The Track Mixer display will appear.

Making a Multi-Track Recording

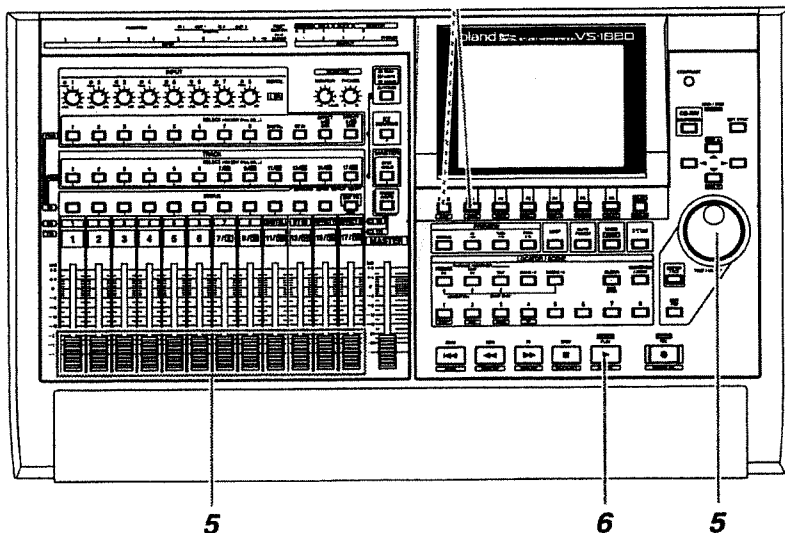

- 4** Press [F1 (MIX)]. If [F1] does not show “MIX,” first press [PAGE] so that “MIX” is displayed, and then press [F1 (MIX)].

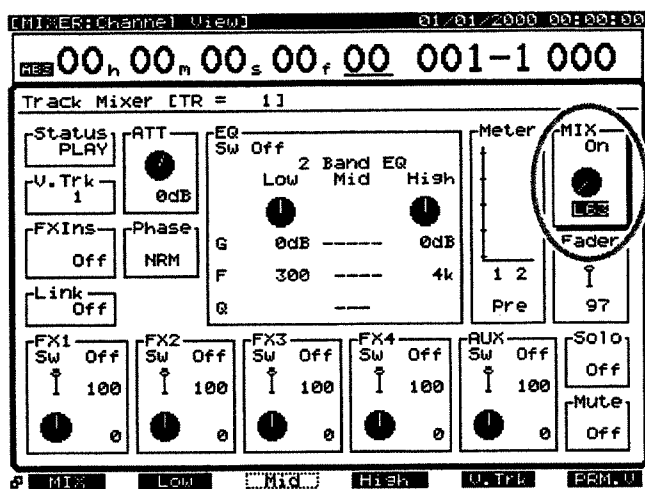

- 5** Use the TIME/VALUE dial to modify the pan setting. For tracks other than the one whose pan you are adjusting, you may wish to lower the channel faders to the lowest position. Repeat steps 1–5 to adjust the pan of the other tracks.

- 6** Press [PLAY]. The song will playback.

MEMO

You can use one of the following methods to check and modify the pan setting of each track in a single display screen. (Pan parameter view screen: owner's manual p.91)

Method 1.

Press [F6 (PRM.V)].

Method 2.

Hold down [SHIFT] and press the track channel 1 [SELECT (CH EDIT)].

NOTE

If you adjust the pan while sound is playing, you may notice “blips” in the sound. This is not a malfunction. If you find it annoying, adjust the pan when the sound is not playing.

MEMO

By holding down [SELECT (CH EDIT)] and turning the MONITOR knob, you can manipulate the panning for the channel.

Adjusting the Tone of Each Track

A selectable 2-band/3-band parametric equalizer is provided for each channel. Here's how to use the equalizer to adjust the tone of each track.

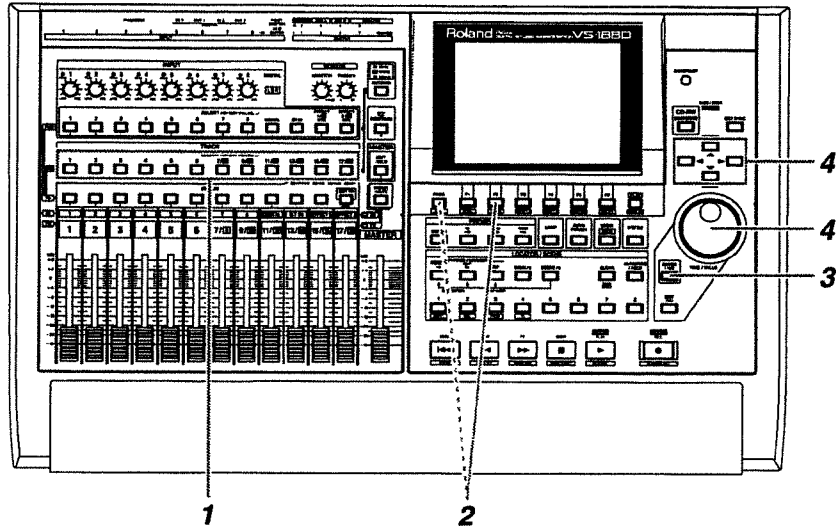

- 1** Press the [SELECT (CH EDIT)] button for the track channel whose equalizer you wish to adjust. [SELECT (CH EDIT)] will light, and the Track Mixer display will appear.
- 2** Press [F2 (Low)]. If [F2] does not show "Low," first press [PAGE] so that "Low" is displayed, and then press [F2 (Low)].
- 3** Press [YES].
- 4** Use [▲] [▼] [◀] [▶] to move the cursor, and use the TIME/VALUE dial to adjust the value of each parameter. For this example, turn the switch "On."

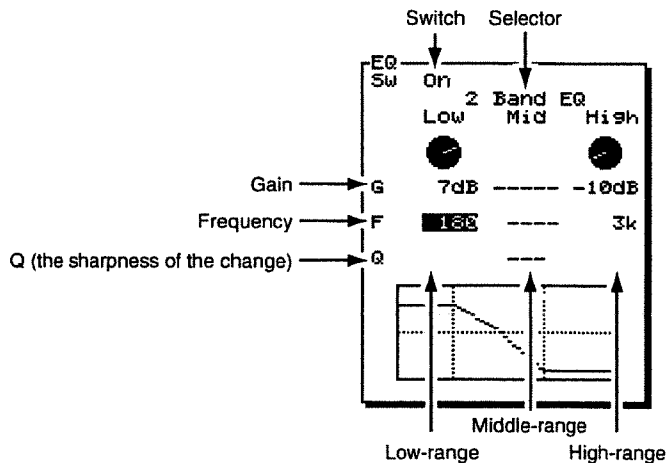

Making a Multi-Track Recording

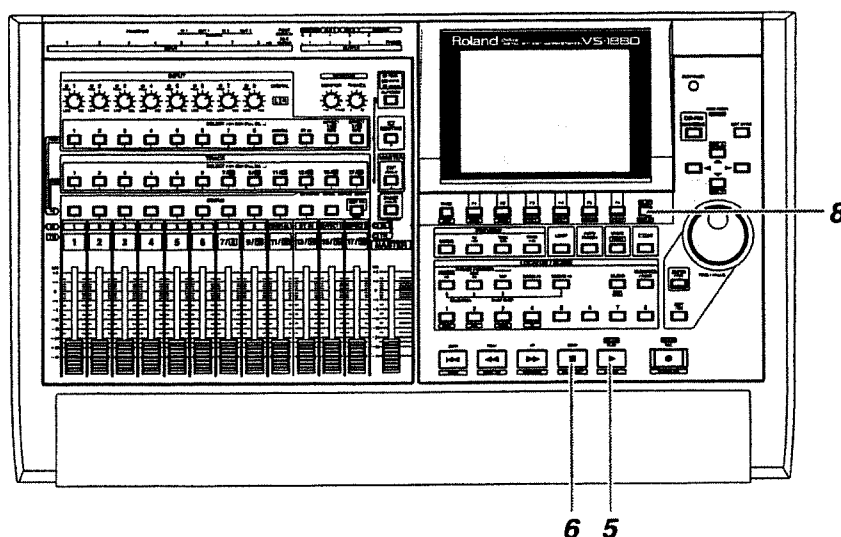

- 5** Press [PLAY]. The song will play back.
- 6** When playback ends, press [STOP].
- 7** If you wish to adjust the equalizer for other tracks, repeat steps 1-6.
- 8** When you finish making adjustments, press [PLAY (DISPLAY)] to return to the original display screen.



If you adjust the equalizer while sound is playing, you may notice "blips" in the sound. This is not a malfunction. If you find it annoying, adjust the equalizer when the sound is not playing.



You can use the selector to choose "3Band EQ." Note that the three-band equalizer can use up to 16 channels simultaneously. You cannot select the three-band equalizer for track channel 17 or 18.



For details refer to "Using the Equalizer (EQ)" (Owner's Manual p.82)

Saving Your Performance (Song Store)

The performance that you recorded will be lost if you simply turn off the power. It will also be lost if the power should be turned off by accident or power failure. Data that was lost in this way cannot be recovered. To avoid such accidents, use the following procedure to save your song to disk. When handling important song data or when you have been using the VS-1880 for an extended period, we recommend that you save your data frequently.



When a song is saved, it will no longer be possible to use the Redo operation (p. 49).

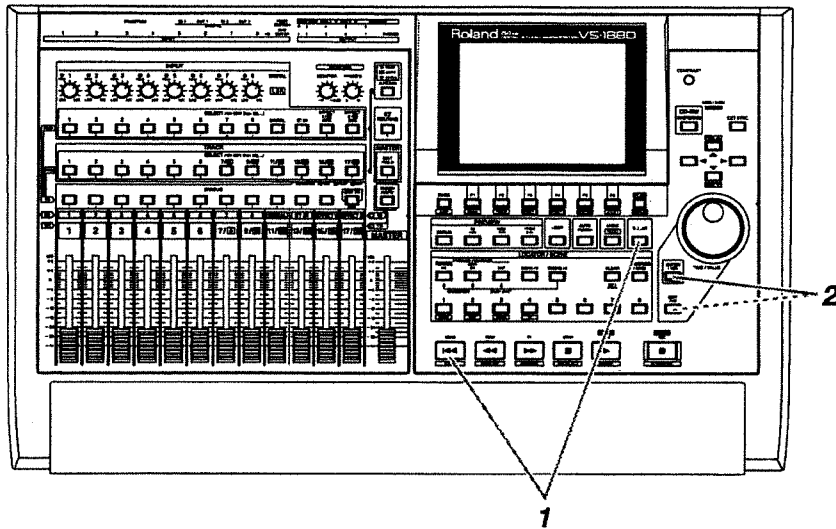

1 Hold down [SHIFT] and press [STORE (ZERO)].

2 "STORE OK ?" will be displayed. If you are satisfied with the recording, press [YES]. If you decide not to store the song, press [NO].



The demo songs are protected so that their contents cannot be modified (Song Protect, Owner's Manual p.51), and cannot be saved. If a demo song is selected when you perform step 1, the display will indicate "Current Song is Protected."

Changing the Partition Size (Drive Initialize)

The VS-1880 can partition a hard disk drive into 500, 1000, or 2000 MB units. If you wish to make very long recordings etc., you can change the partition size to 2,000 MB.

When you change the partition size, the change will take effect after the hard disk is initialized. **When the hard disk is initialized, the entire contents of the disk will be erased.** Make sure that the hard disk does not contain data you need to keep. If necessary, back up the data to the Roland CD recorder, an external hard disk drive, a DAT tape, etc.

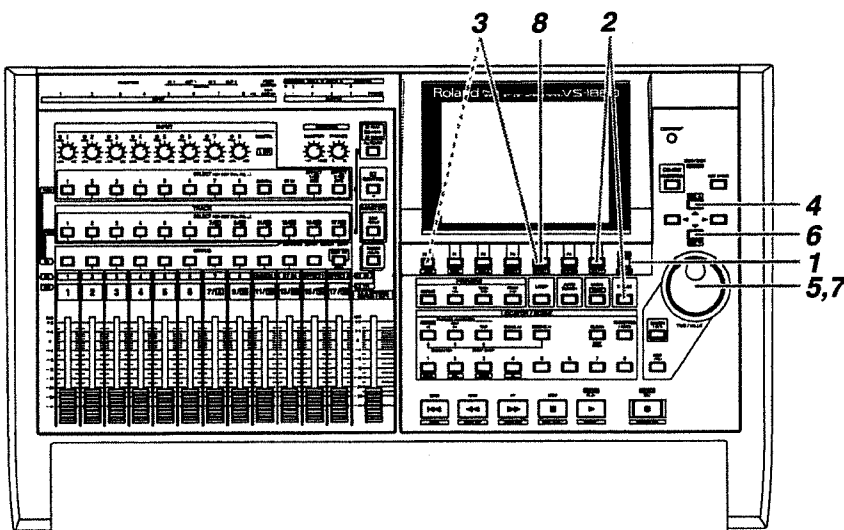

- 1 Press [PLAY (DISPLAY)].
- 2 Hold down [SHIFT] and press [F6 (UTILITY)]. The Utility menu icons will appear.

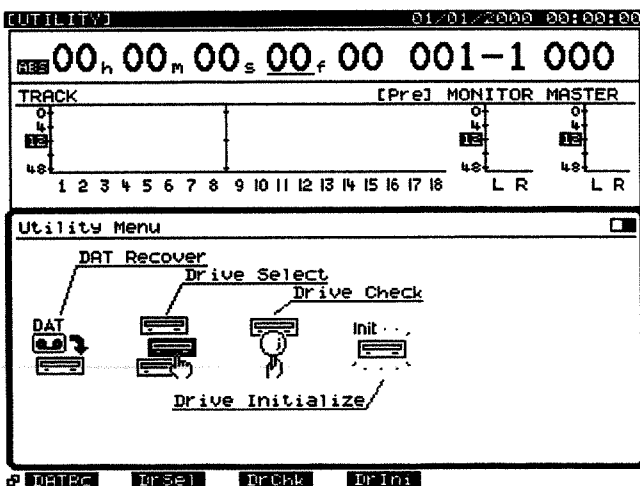

If important data is erased by mistake, there is no way to recover it. Roland can take no responsibility of any kind for the recovery of any lost data or any damages incurred thereby. When a single hard disk or other disk is divided into partitions, it is not possible to initialize only an individual partition. The Drive Initialize operation will be performed on all partitions of that disk drive or other disk.

In order to backup VS-880 or VS-880EX formatted song, it must be converted to a VS-1880 song using the Song Import function.



For details refer to "Song Import" (Owner's Manual p.243).

- 3** Press [F4 (DrIni)]. If [F4] does not show "DrIni," first press [PAGE] so that "DrIni" appears, and then press [F4 (DrIni)].

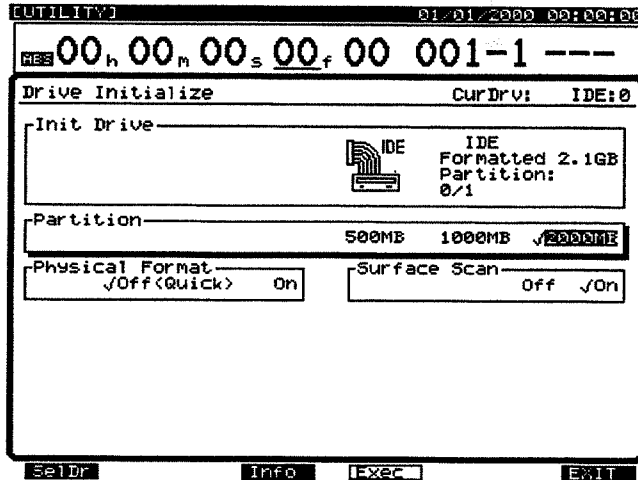

- 4** Press [▲] to move the cursor to "Init Drive."
- 5** Use the TIME/VALUE dial to select the disk drive that you wish to initialize (IDE, SCSI0-SCSI7). For this example, select "IDE."
- 6** Press [▼]. The cursor will move to "Partition."
- 7** Use the TIME/VALUE dial to select the partition size (500MB, 1000MB, 2000MB). For this example select "2000 MB."
- 8** Press [F4 (Exec)]. The display will ask "Initialize *****, OK ?" The "*****" will indicate the SCSI ID number of the drive. In the case of the internal hard disk, this will indicate "IDE."

Making a Multi-Track Recording

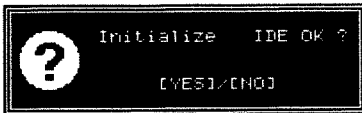
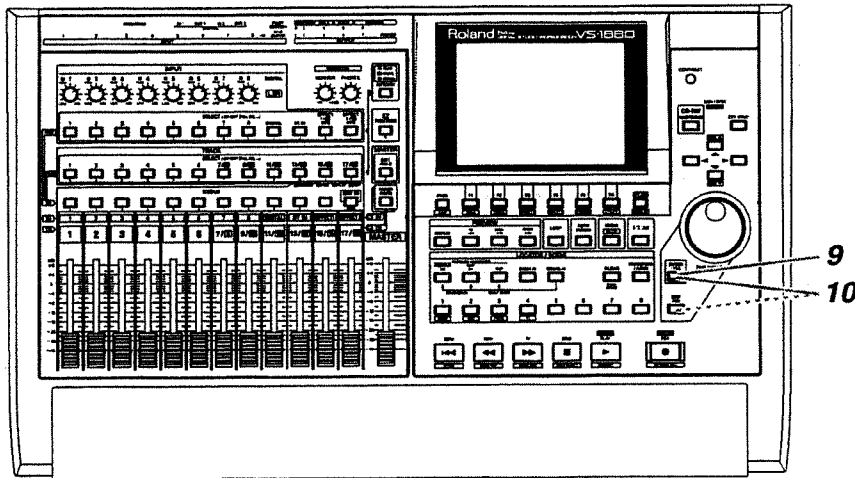

- 9 Press [YES]. The display will ask "Initialize *****, Sure?" (Do you really want to initialize?)
- 10 Press [YES] to execute the Initialize operation. If you decide not to initialize, press [NO].
- 11 When initialization is completed, the VS-1880 will automatically restart.

Surface Scan

When you initialize a hard disk, you can check the entire area of that drive to verify that read/write can be performed correctly. This operation is called **Surface Scan**. When Surface Scan is performed, it will require somewhat more time to initialize the drive, but the reliability of the hard disk will be enhanced. **We recommend that you also perform Surface Scan when you initialize a drive.**

If you wish to perform Surface Scan, perform the following steps between steps 7 and 8 of the above procedure.

1. Use [▼] [▶] to move the cursor to "Surface Scan."
2. Use the TIME/VALUE dial to select "On."

NOTE

A certain length of time is required in order to initialize a disk drive. This is not a malfunction. Do not turn off the power until initialization is finished.



For details refer to "Checking Disk Reliability using Surface Scan" (Owner's Manual p.229)

Using Effects (When VS8F-2s are Installed)

If VS8F-2 effect expansion boards (sold separately) are installed, you can use up to four stereo effects without needing to connect any external devices to the VS-1880. Here's how to use effects when VS8F-2s have been installed.

If the Display Indicates "No Effect Board"

A VS8F-2 has not been installed. Internal effects cannot be used.

If this message appears even though a VS8F-2 has been installed, the VS8F-2 has not been recognized correctly. Turn off the power as described in "Turning Off the Power" (p. 19), and re-install the effect expansion board correctly.

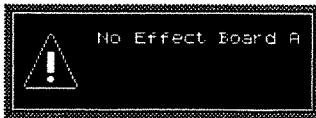

MEMO

For details on installing a VS8F-2, refer to "Installing Effect Expansion Boards" (p. 8).

Applying a Send/Return Type Effect During Playback

It is common to apply a send/return type effect such as reverb or delay during playback. The following example shows how you can apply reverb (FX1) to track 1 during playback.

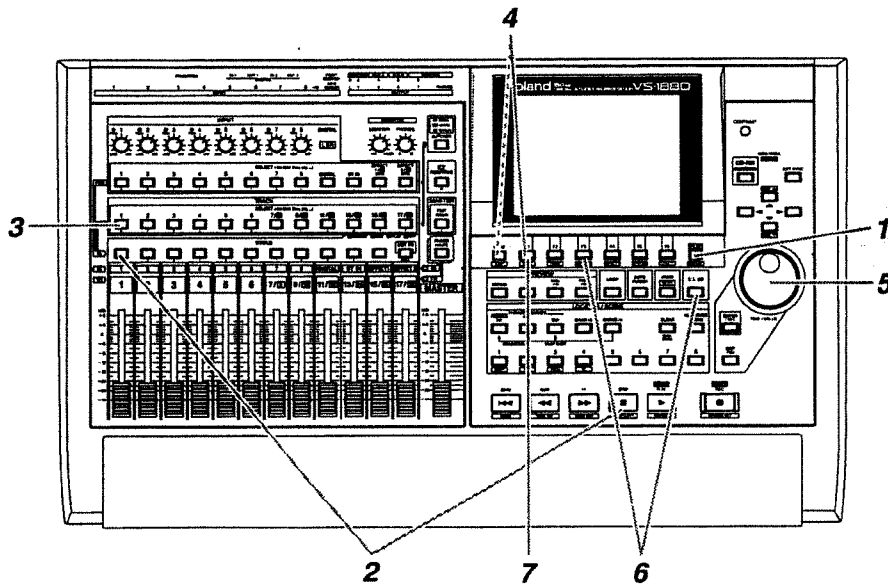

- 1** Press [PLAY (DISPLAY)].
- 2** Select the track(s) for playback. Hold down [STOP] and press the track 1 [STATUS] button. [STATUS] will light green.
- 3** Press the [SELECT] button for the track channel to which you wish to apply the effect. For this example, press the track channel 1 [SELECT] button. [SELECT] will light, and the Track Mixer display will appear.
- 4** Press [F1 (FX1)]. If [F1] does not show "FX1," first press [PAGE] so that "FX1" appears, and then press [F1 (FX1)].

Using Effects (When VS8F-2s are Installed)

- Use the TIME/VALUE dial to turn the effect on/off. Select either "Pre" or "Pst." For this example, select "Pst" so that the effect will be applied to the sound that has passed through the channel fader.

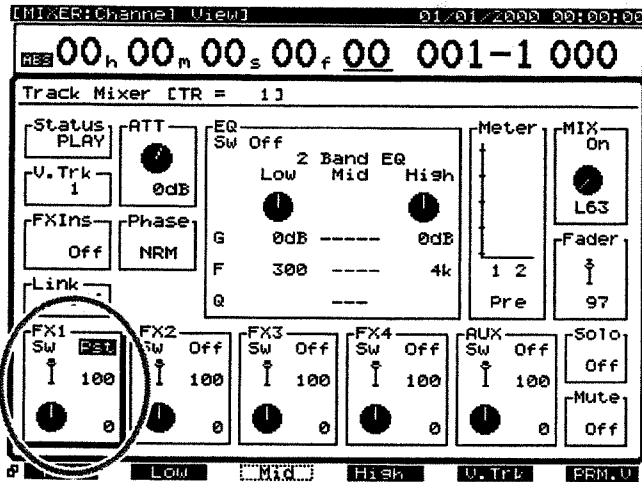

- Hold down [SHIFT] and press [F3 (FX A)]. The Effect A menu will appear. If the Effect A menu does not appear, press [F6 (EXIT)].

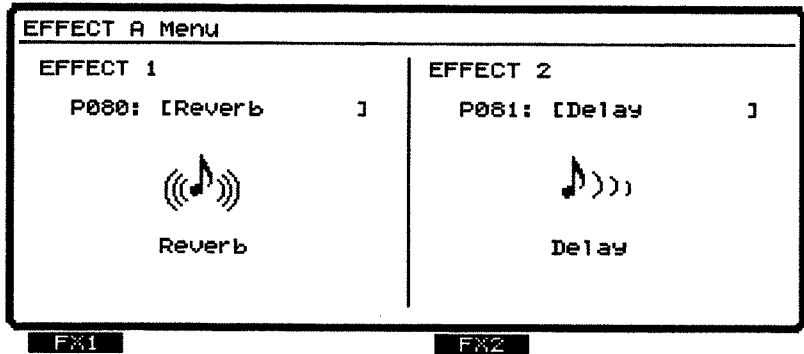

- Press [F1 (FX1)].

Using Effects (When VS8F-2s are Installed)

Using Effects (When VS8F-2s are Installed)

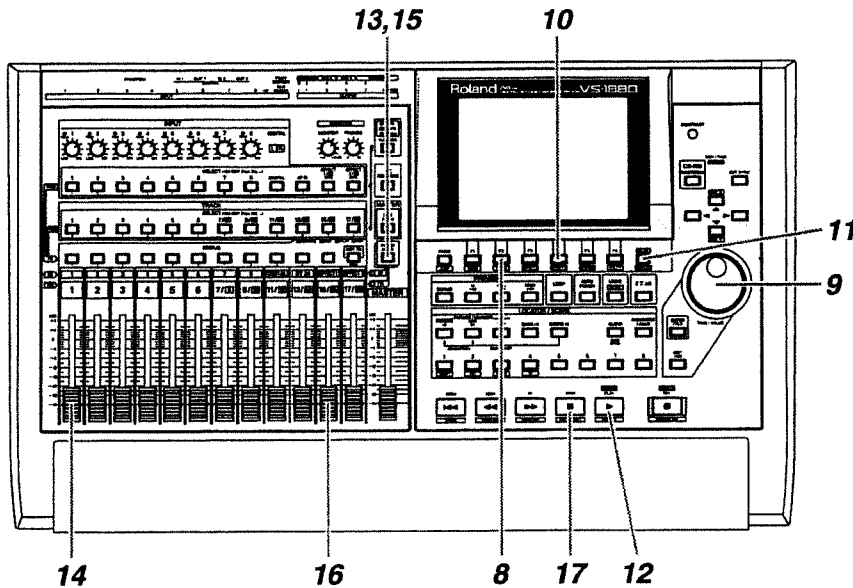

8 Select the effect. Press [F2 (Sel)]. A list of effects will appear.

9 Use the TIME/VALUE dial to move the cursor to the effect that you wish to use. For this example, select an effect such as "P000 RV:LargeHall."

EFFECT1 Select	Cur	P000	:[Reverb]
P000	:[RV:LargeHall]	P010	:[RV:Vocal Pit]
P001	:[RV:SmallHall]	P011	:[RV:Soft Amb.]
P002	:[RV:Strings]	P012	:[RV:Room Amb.]
P003	:[RV:PianoHall]	P013	:[RV:Cathedral]
P004	:[RV:Orch Room]	P014	:[RV:Long Cave]
P005	:[RV:VocalRoom]	P015	:[RV:GarageDr.]
P006	:[RV:MediumRm]	P016	:[RV:Rock Kick]
P007	:[RV:LargeRoom]	P017	:[RV:Rock Share]
P008	:[RV:Cooplate]	P018	:[RV:BruteGate]
P009	:[RV:Short Pit]	P019	:[RV:Fat Gate]

10 After you have selected an effect, press [F4 (Exec)].

11 Preparations are now complete. Press [PLAY (DISPLAY)] to return to the original display.

12 Press [PLAY]. The song will play back.

13 Press [FADER] so that the TR (track) indicator is lit.

Using Effects (When VS8F-2s are Installed)

- 14** Use channel fader 1 to adjust the volume of track 1.
- 15** Press [FADER] so that the IN (input) indicator is lit.
- 16** Use channel fader 15/16 (EFFECT1) to adjust the effect return level.
- 17** When the song ends, press [STOP].

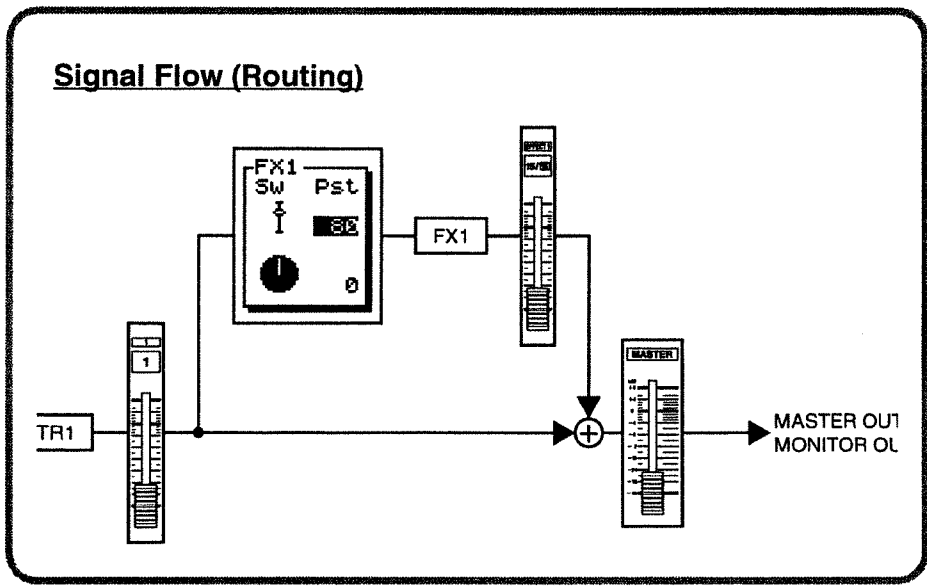

Using Effects
(When VS8F-2s are installed)

Applying a Send/Return Type Effect Only to the Monitor Sound as You Record

The following example shows how a source connected to the INPUT 1 jack can be recorded on track 2 directly (without effects) while you apply a send/return type effect such as reverb or delay to the monitor sound. This is convenient when you wish to hear a reverb (FX1) on a vocal (for example) as you record, but would like to try out various reverb settings during playback.

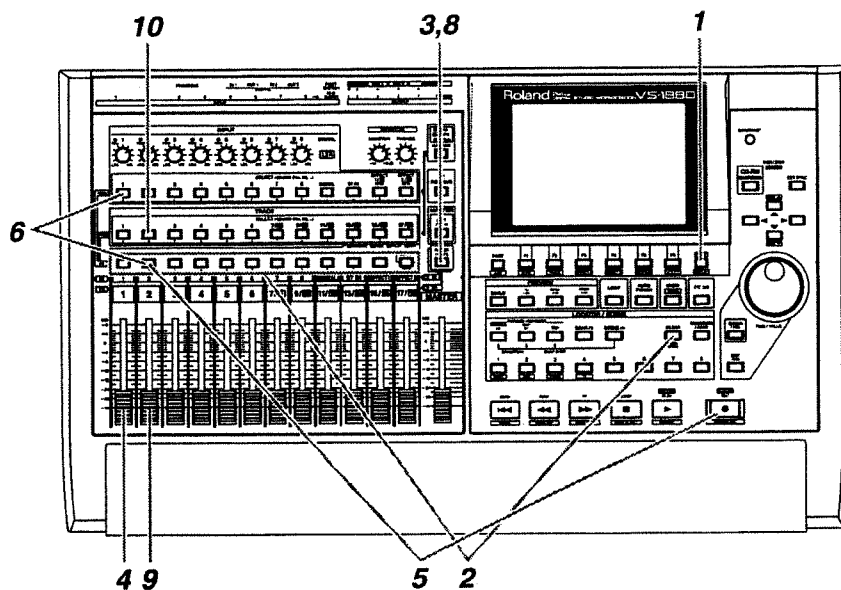

- 1 Press [PLAY (DISPLAY)].
- 2 Hold down a [STATUS] button (of any track) and press [CLEAR].
- 3 Press [FADER] so that the IN (input) indicator is lit.
- 4 Raise and lower channel fader 1, and verify that the volume changes. The input channel fader is used to make fine adjustments to the recording level. In order to record with optimal audio quality, the fader should normally be set in the 0 dB position.

MEMO

This will clear any existing input and/or track routing assignments.

Using Effects (When VS8F-2s are Installed)

5 Select the track for recording. Hold down [REC], and press the [STATUS] button of the track that you wish to record. For this example, hold down [REC] and press the track 2 [STATUS] button. [STATUS] will blink red.

6 Select the source that will be recorded on the track. Hold down the [STATUS] button of the track that you wish to record, and press the [SELECT] button of the input channel that you wish to assign as the source. For this example, hold down the track 2 [STATUS] button and press the input channel 1 [SELECT] button. [SELECT] will blink.

7 If you continue holding [STATUS] for a time, you can see the source that is assigned to the track.

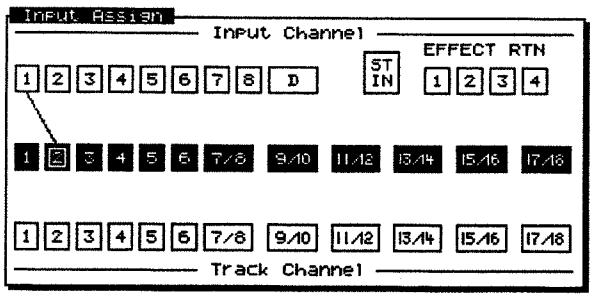

8 Press [FADER] so that the TR (track) indicator is lit.

9 Raise and lower channel fader 2, and verify that the volume changes. The track channel fader is used for monitoring. It does not affect the recording level. You can record even if you hear no sound. Adjust the fader to a comfortable level for monitoring.

10 Press the [SELECT] button for the channel to which you wish to apply the effect. For this example, press the track channel 2 [SELECT] button. [SELECT] will light, and the Track Mixer display will appear.

MEMO

At this time, the sound of input channel 1 will no longer be output directly from master out.

Using Effects
(When VS8F-2s are Installed)

Using Effects (When VS8F-2s are Installed)

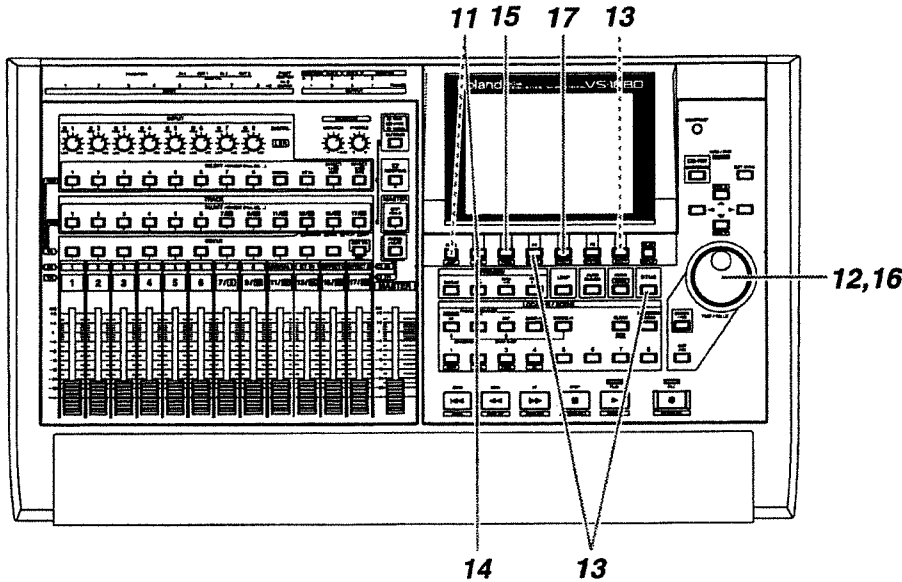

11 Press [F1 (FX1)]. If [F1] does not show “FX1,” press [PAGE] so that “FX1” appears, and then press [F1 (FX1)].

12 Use the TIME/VALUE dial to turn the effect on/off. Select either “Pre” or “Pst.” For this example, select “Pst” so that the effect will be applied to the sound after it has passed through the channel fader.

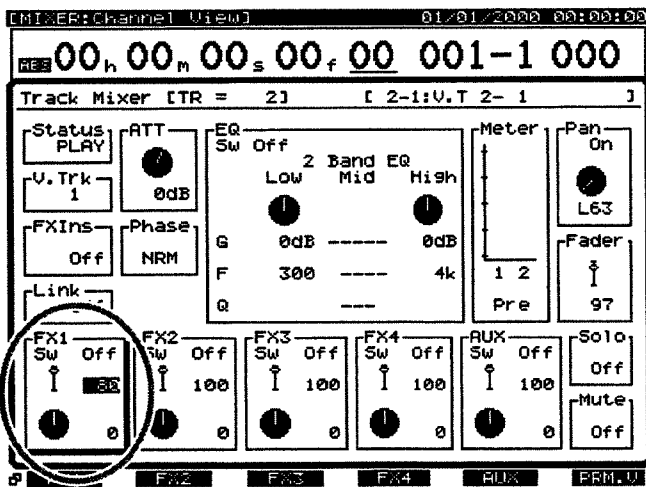

Using Effects (When VS8F-2s are Installed)

13 Hold down [SHIFT] and press [F3 (FX A)]. The Effect A menu will appear. If the Effect A menu does not appear, press [F6 (EXIT)].

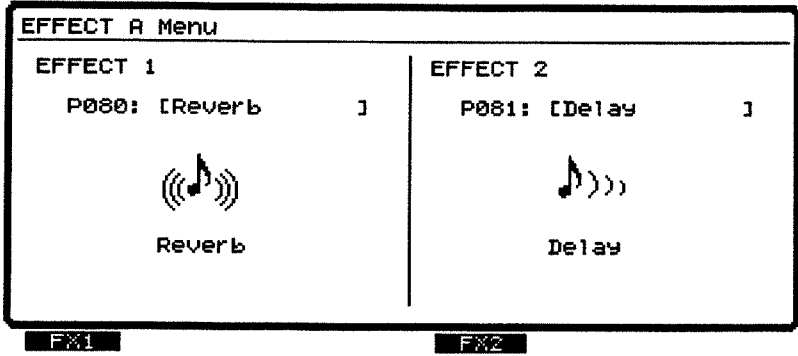

14 Press [F1 (FX1)].

15 Select an effect. Press [F2 (Sel)], and a list of effects will appear.

16 Use the TIME/VALUE dial to move the cursor to the effect you wish to use. For this example, select an effect such as "P000 RV:LargeHall."

EFFECT1 Select	Cur	P080 :[Reverb]
P000 :[RV:LargeHall]		P010 :[RV:Vocal P1t]
P001 :[RV:SmallHall]		P011 :[RV:Soft Amb.]
P002 :[RV:Strings]		P012 :[RV:Room Amb.]
P003 :[RV:PianoHall]		P013 :[RV:Cathedral]
P004 :[RV:Orch Room]		P014 :[RV:Long Cave]
P005 :[RV:VocalRoom]		P015 :[RV:GarageDr.]
P006 :[RV:MediumRm]		P016 :[RV:Rock Kick]
P007 :[RV:LargeRoom]		P017 :[RV:RockSnare]
P008 :[RV:CoolPlate]		P018 :[RV:BrightGate]
P009 :[RV:Short P1t]		P019 :[RV:Fat Gate]

17 After selecting an effect, press [F4 (Exec)].

Using Effects (When VS8F-2s are Installed)

Using Effects (When VS8F-2s are Installed)

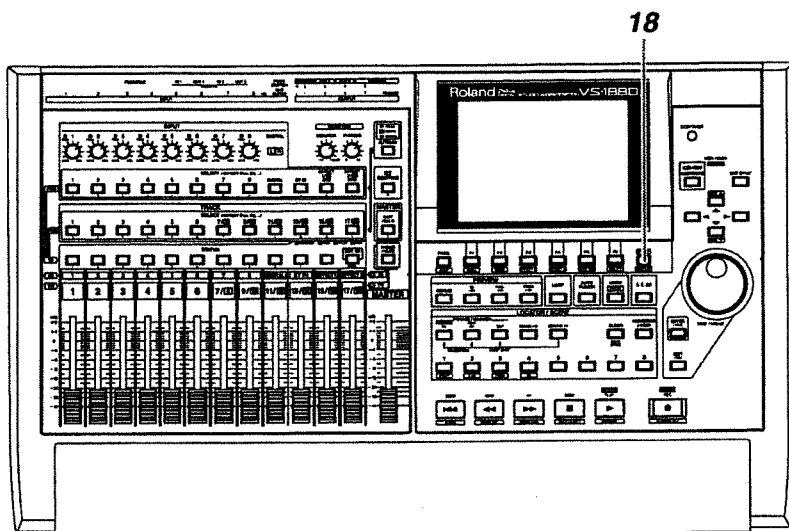

18 Press [PLAY (DISPLAY)] to return to the original display screen.

19 As described in "Recording On a Track" (p. 42), record a performance and then listen to it.

Signal Flow (Routing)

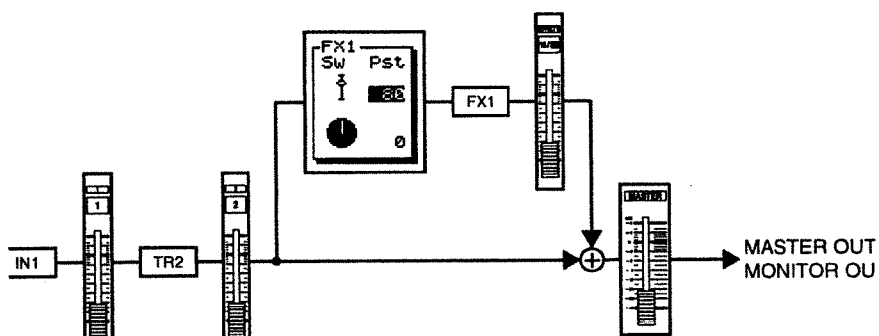

Switching Effects During Playback

Here's how you can switch effects while you playback a song, to hear the differences between various effects.

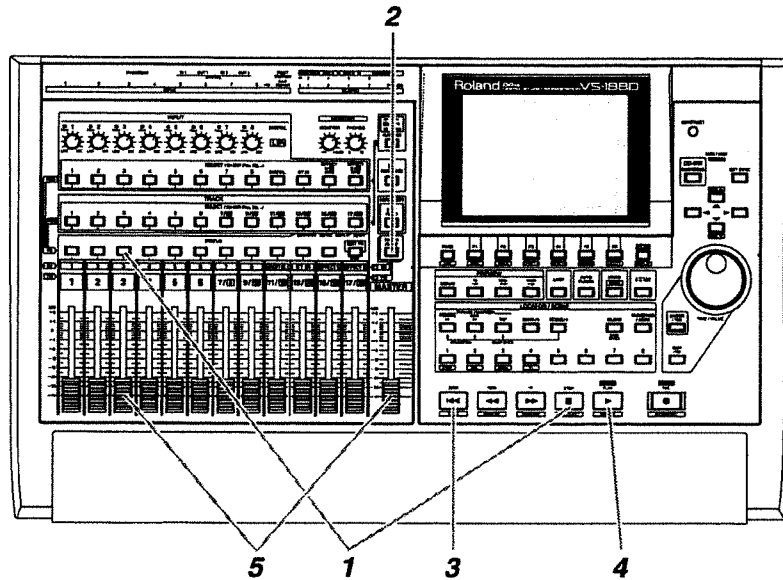

- 1** Select the track(s) for playback. Hold down [STOP] and press the [STATUS] button for the track(s) that you wish to playback. For this example, hold down [STOP] and press the track 3 [STATUS] button. To this point in the examples, we have not recorded anything on track 3.
- 2** Press [FADER] so that the TR (track) indicator is lit.
- 3** Press [ZERO]. You will return to the beginning of the song.
- 4** Press [PLAY]. The song will play back.
- 5** Use channel fader 3 and the master fader to adjust the volume to a comfortable level for listening.

Using Effects (When VS8F-2s are Installed)

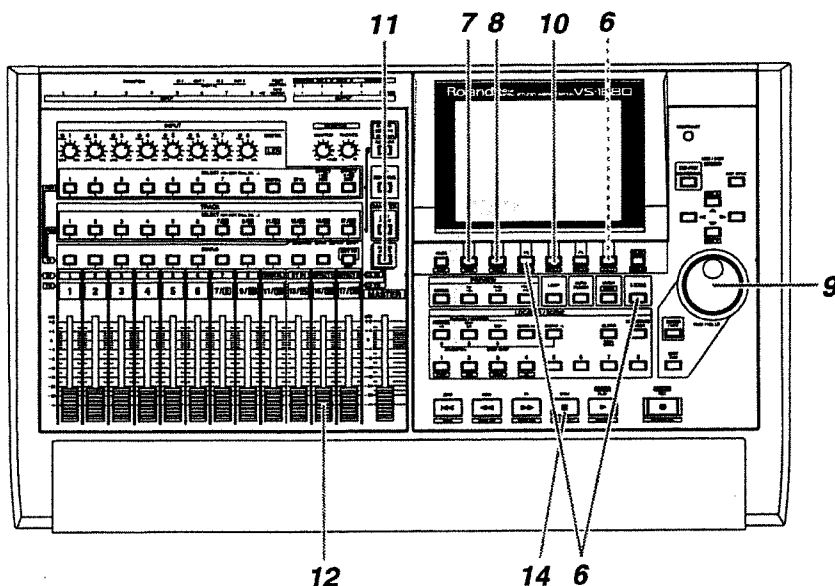

- 6** Hold down [SHIFT] and press [F3 (FX A)]. The Effect A menu will appear. If the Effect A menu does not appear, press [F6 (EXIT)].

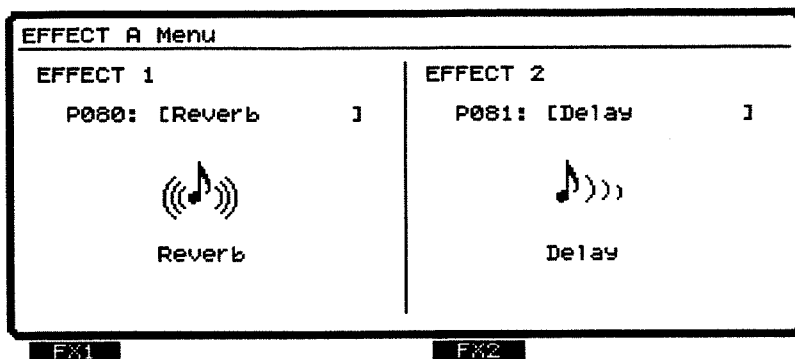

- 7** Press [F1 (FX1)].
- 8** Select an effect. Press [F2 (Sel)], and a list of effects will appear.
- 9** Use the TIME/VALUE dial to move the cursor to the effect that you wish to select. The difference will be easy to hear if you select an effect such as "P005:RV:VocalRoom."

Using Effects (When VS8F-2s are Installed)

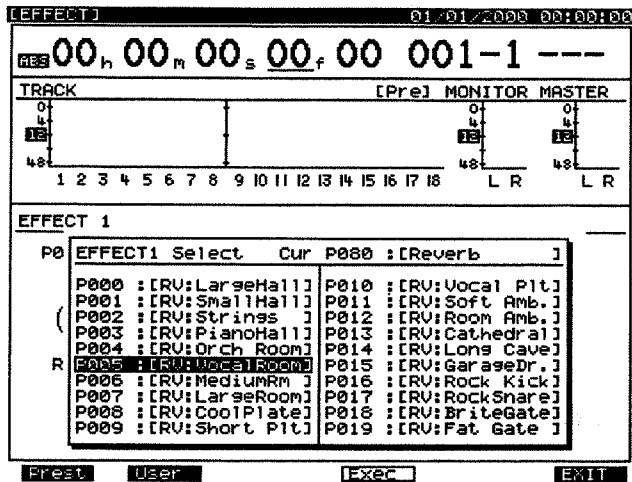

- 10 After you have selected an effect, press [F4 (Exec)].
- 11 Press [FADER] so that the IN (input) indicator is lit.
- 12 Use channel fader 15/16 (EFFECT1) to adjust the effect return level.
- 13 If you wish to hear other effects, repeat steps 8–12.
- 14 When the song ends, press [STOP].

Using Effects (When VS8F-2s are Installed)

Applying a Send/Return Type Effect While You Record

Here we will give an example of how a send/return type effect such as reverb can be applied to the source of the INPUT 1 jack, and the direct sound and effect sound recorded together on track 3. This is the method you will use when, for example, you wish to apply reverb to a vocal and record both the direct sound and effect sound together.

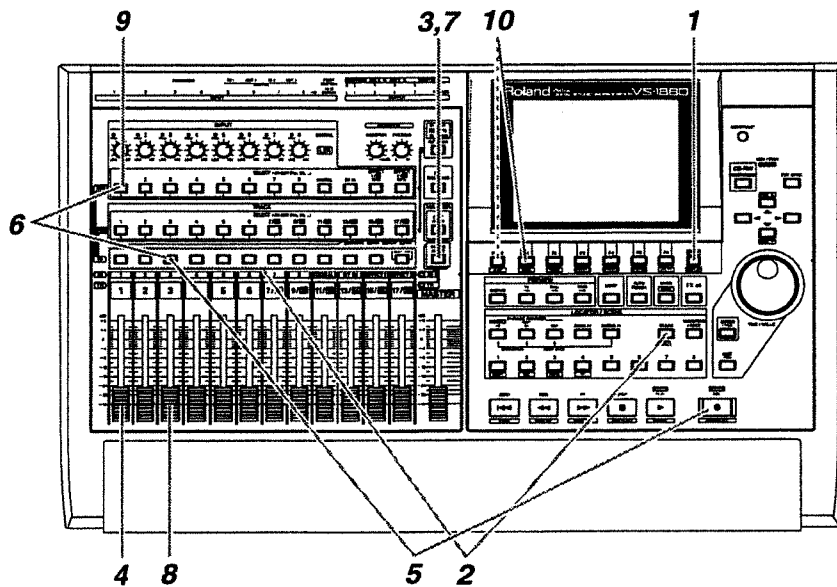

- 1** Press [PLAY (DISPLAY)].
- 2** Hold down a [STATUS] button (of any track) and press [CLEAR].
- 3** Press [FADER] so that the IN (input) indicator is lit.
- 4** Raise and lower channel fader 1, and verify that the volume of the source changes. The input channel fader is used to make fine adjustments to the recording level. For optimal recording quality, the fader should normally be placed in the 0 dB position.

MEMO

This will clear any existing input and/or track routing assignments.

Using Effects (When VS8F-2s are Installed)

- 5** Select the track that you wish to record. Hold down [REC], and press the [STATUS] button of the track that you wish to record. For this example, hold down [REC] and press the track 3 [STATUS] button. [STATUS] will blink red.
- 6** Select the source that will be recorded on the track. Hold down the [STATUS] button of the track that you wish to record, and press the [SELECT] button of the input channel that you wish to assign as the source. For this example, hold down the [STATUS] button of track 3, and press the input channel 1 [SELECT] button so it begins to blink.
- 7** Press [FADER] so that the TR (track) indicator is lit.
- 8** Raise and lower channel fader 3, and verify that the volume changes. The track channel fader is used for monitoring. It does not affect the recording level. You can record even if no sound is heard. Adjust the fader to a comfortable volume for listening.
- 9** Press the [SELECT] button of the channel to which you wish to apply the effect. For this example, press the input channel 1 [SELECT] button. [SELECT] will light, and the Input Mixer display will appear.
- 10** Press [F1 (FX1)]. If [F1] does not show "FX1," first press [PAGE] so that "FX1" appears, and then press [F1 (FX1)].

MEMO

At this time, the sound of input channel 1 will no longer be output directly from master out.

Using Effects (When VS8F-2s are Installed)

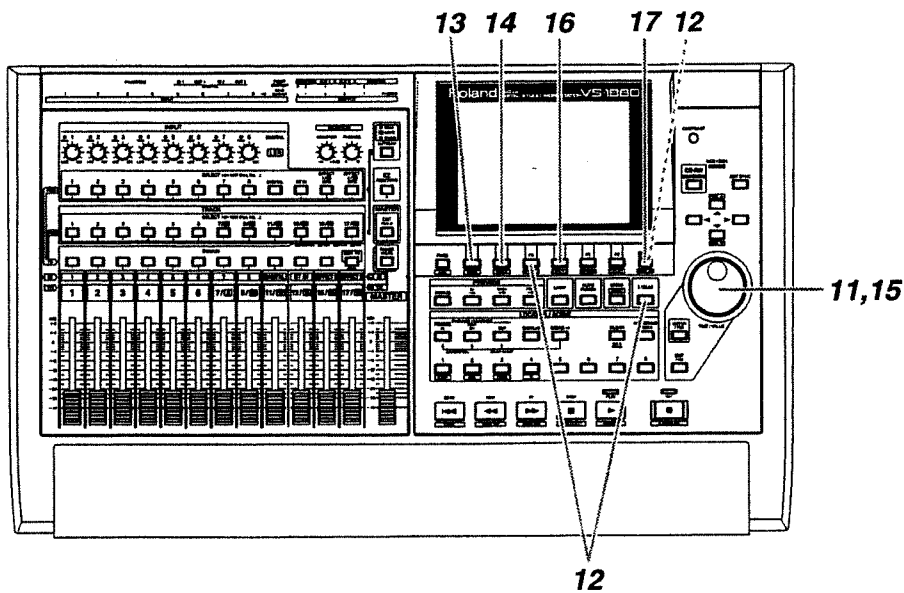

- 11** Use the TIME/VALUE dial to turn the effect on/off. Select either "Pre" or "Pst." For this example, select "Pst" so that the effect will be applied to the sound that has passed through the channel fader.

NOTE

Be sure to turn off the effect switch of track channel 3. Otherwise, you will create a feedback loop.

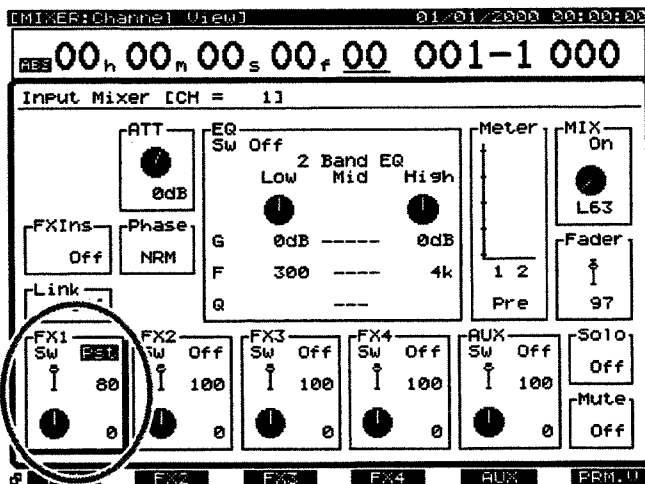

- 12** Hold down [SHIFT] and press [F3 (FX A)]. The Effect A menu will appear. If the Effect A menu does not appear, press [F6 (EXIT)].

Using Effects (When VS8F-2s are Installed)

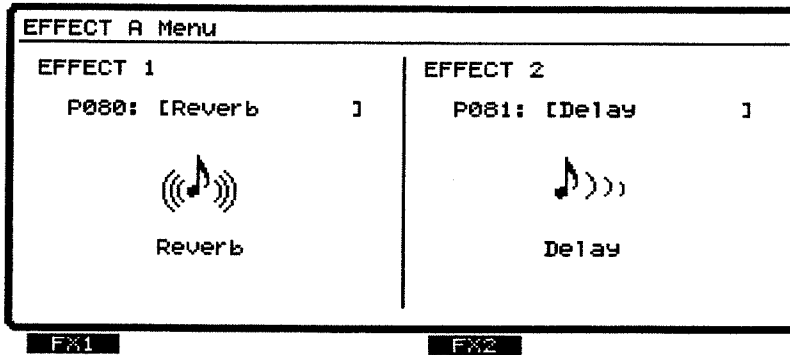

13 Press [F1 (FX1)].

14 Select an effect. Press [F2 (Sel)]. A list of effects will appear.

15 Use the TIME/VALUE dial to move the cursor to the effect that you wish to use. For this example, select an effect such as "P000 RV:LargeHall."

EFFECT1 Select	Cur	P080 : [Reverb]
P000 : [RV:LargeHall]	P010 : [RV:Vocal P1t]	
P001 : [RV:SmallHall]	P011 : [RV:Soft Amb.]	
P002 : [RV:Strings]	P012 : [RV:Room Amb.]	
P003 : [RV:PianoHall]	P013 : [RV:Cathedral]	
P004 : [RV:Orch Room]	P014 : [RV:Long Cave]	
P005 : [RV:VocalRoom]	P015 : [RV:GarageDr.]	
P006 : [RV:MediumRm]	P016 : [RV:Rock Kick]	
P007 : [RV:LargeRoom]	P017 : [RV:RockShare]	
P008 : [RV:CoolPlate]	P018 : [RV:Br1teGate]	
P009 : [RV:Short P1t]	P019 : [RV:Fat Gate]	

16 After you have selected an effect, press [F4 (Exec)].

17 Press [PLAY (DISPLAY)] to return to the original display screen.

Using Effects (When VS8F-2s are Installed)

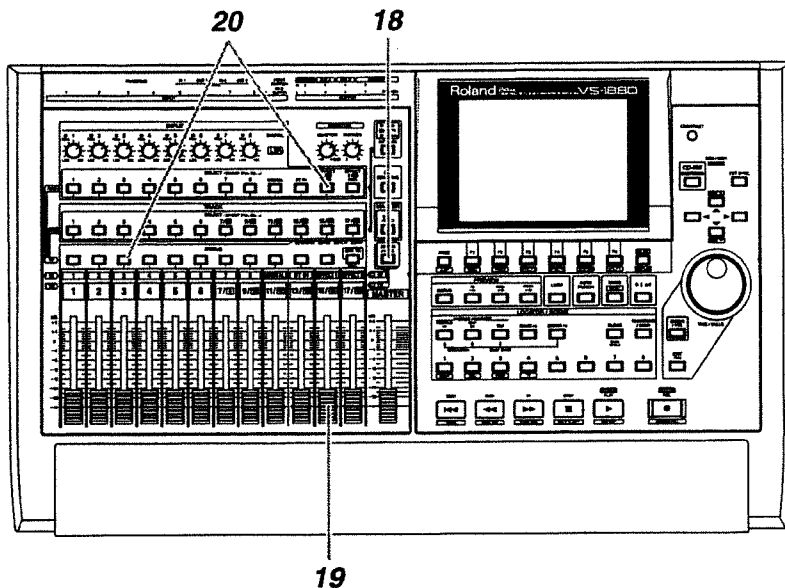

18 Press [FADER] so that the IN (input) indicator is lit.

19 Raise and lower channel fader 13/14 (EFFECT1), and verify that the effect return volume changes. The input channel fader is used to make fine adjustments to the recording level. Set it to an appropriate position.

20 Assign the effect return to the recording track. Hold down the track 3 [STATUS] button, and press the [EFFECT1 RTN] of the input channel. [EFFECT1 RTN] will blink.

21 If you continue holding [STATUS] for a time, you can see the source and effect return that is assigned to the track.

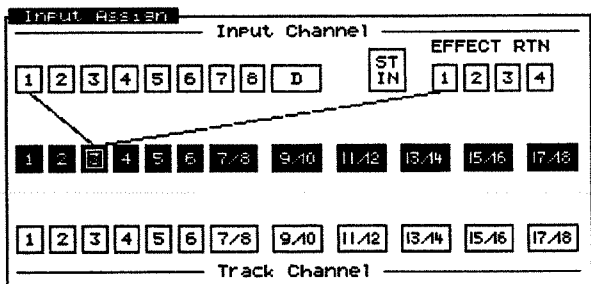

MEMO

At this time, the return signal from the effect will no longer be output directly to the master out.

22 As described in "Recording On a Track" (p. 42), record a performance and listen to it.

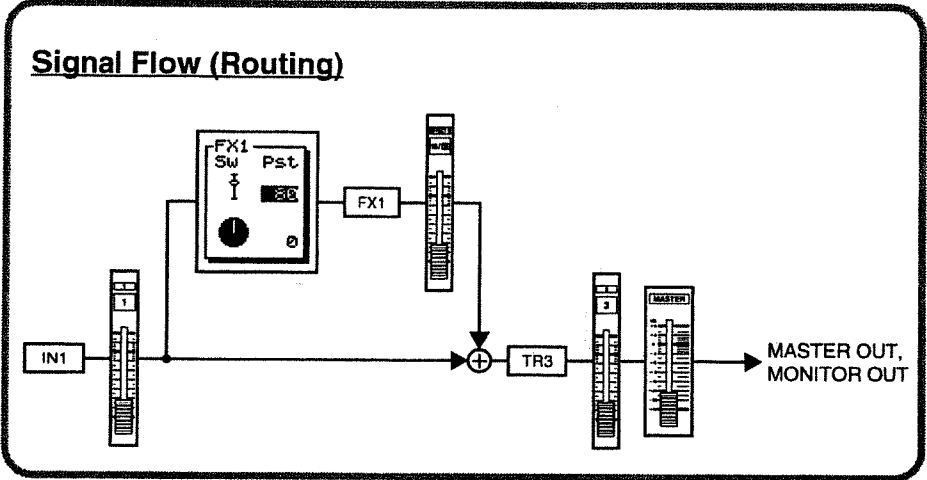

Applying an Insertion-Type Effect During Playback

When playing back an acoustic guitar or vocal, it is common to insert an effect such as "Guitar Multi" or "Vocal Multi." Here we will give an example of applying an insertion-type effect such as Mic Simulator (FX2) to track 1 during playback.

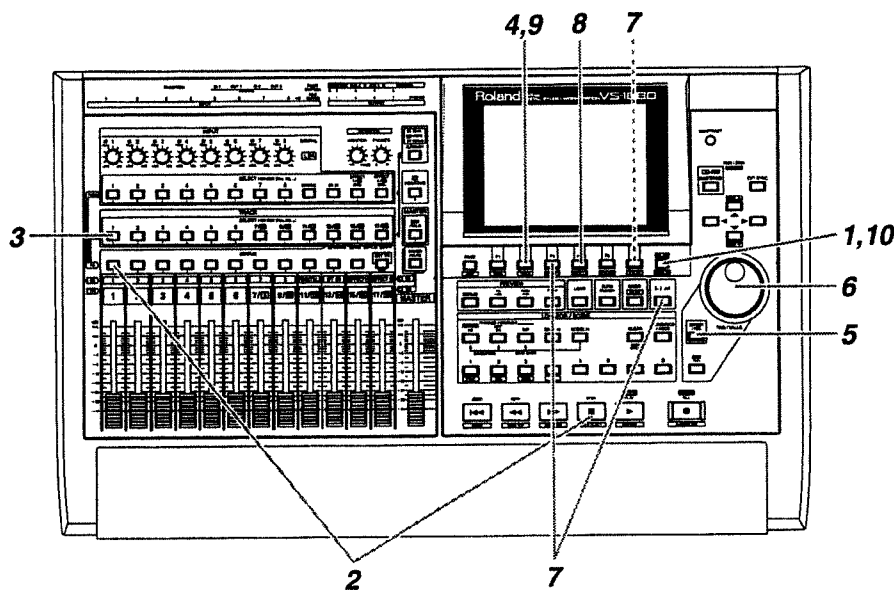

- 1** Press [PLAY (DISPLAY)].
- 2** Select the track that you wish to playback. Hold down [STOP] and press the track 1 [STATUS] button. [STATUS] will light green.
- 3** Press the [SELECT] button for the track channel to which you wish to apply the effect. For this example, press the track channel 1 [SELECT] button. [SELECT] will light, and the Track Mixer display will appear.
- 4** Press [F2 (FX2In)]. If [F2] does not show "FX2In," first press [PAGE] so that "FX2In" appears, and then press [F2 (FX2In)].
- 5** Press [YES].

Using Effects (When VS8F-2s are Installed)

- 6** Use the TIME/VALUE dial to select how effect 2 will be inserted. For this example, select "Ins."

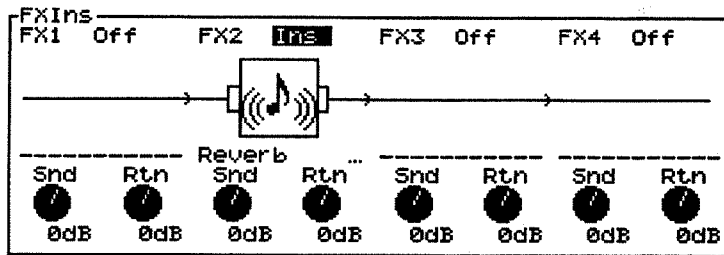

NOTE

If the display indicates "FX2--," the effect (FX2) is inserted into another channel, and therefore cannot be inserted into this channel (p. 95). Either turn off effect insertion for the channel that is using the effect, or insert a different effect into this channel.

- 7** Hold down [SHIFT] and press [F3 (FX A)]. The Effect A menu will appear. If the Effect A menu does not appear, press [F6 (EXIT)].

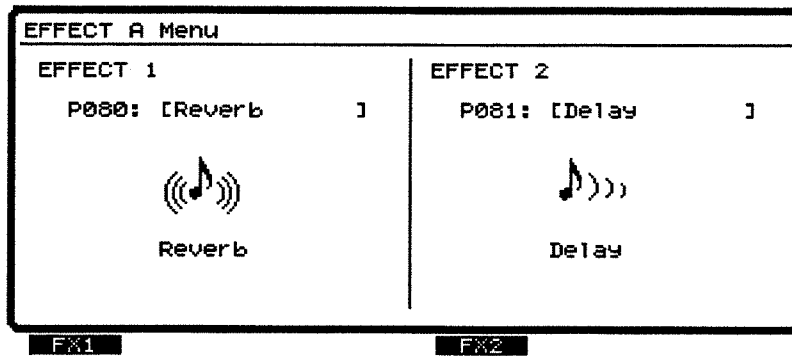

- 8** Press [F4 (FX2)].
- 9** Select an effect. Press [F2 (Sel)]. A list of effects will appear.
- 10** Use the TIME/VALUE dial to move the cursor to the effect that you wish to use. For this example, select an effect such as "P128 MS:DR20→87."

EFFECT2 Select	Cur	P081 : [Delay]
P120 : [MS:57→58]]	P130 : [MS:10→87]
P121 : [MS:57→421]]	P131 : [MS:Mini→57]
P122 : [MS:57→451]]	P132 : [MS:Mini→87]
P123 : [MS:57→87]]	P133 : [MS:Kick&Snr1]
P124 : [MS:57→47]]	P134 : [MS:Kick&Snr2]
P125 : [MS:57→Line]]	P135 : [MS:H. Hat&Tom]
P126 : [MS:DR20→421]]	P136 : [MS:Dr. Ovr Top]
P127 : [MS:DR20→451]]	P137 : [MS:Dr. Ovr All]
P128 : [MS:DR20→87]]	P138 : [MS:Ac. Guitar]
P129 : [MS:10→58]]	P139 : [MS:StudioUC1]

Using Effects (When VS8F-2s are Installed)

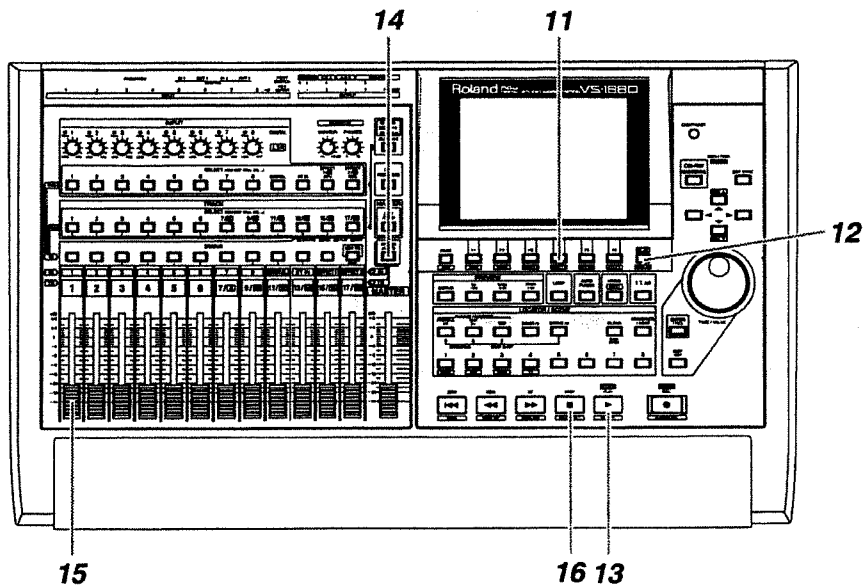

- 11** After you have selected an effect, press [F4 (Exec)].
- 12** Press [PLAY (DISPLAY)] to return to the original display screen.
- 13** Press [PLAY]. Notice that the effect is applied to the sound.
- 14** Press [FADER] so that the TR (track) indicator is lit.
- 15** Use channel fader 1 to adjust the volume of track 1.
- 16** When the song ends, press [STOP].

Signal Flow (Routing)

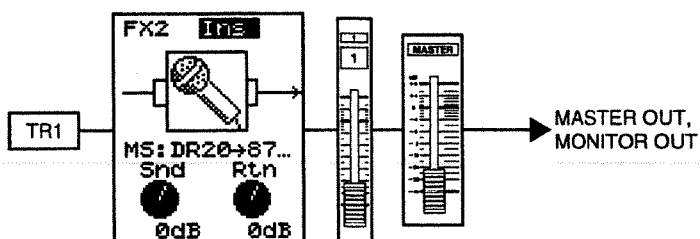

Using Effects (When VS8F-2s are Installed)

Inserting the Same Effect into Another Track as Well

If in step 6 you selected "Ins" or "InsS," that effect cannot be inserted into another channel/track. If you chose "InsL" or "InsR," you can use the other effect on another channel or track with Insert.

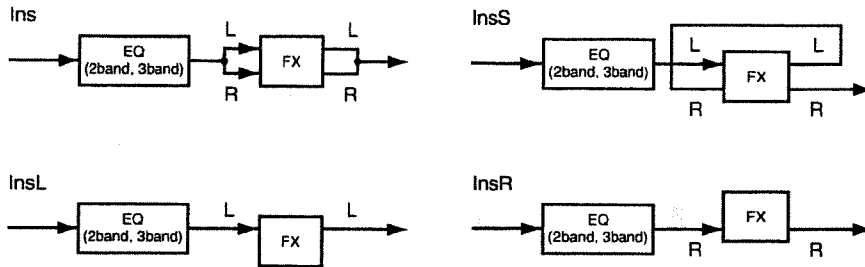

If You Wish to Use the Same Effect Both as Send/Return and Insertion

It is not possible to use the same effect for both insertion and send/return.

Even if the "FXIns" parameter is set to "Ins," the "FX Sw" parameter can be set to either "Pre" or "Pst." This is because the VS-1880 is able to send the signal of the FX bus not only to the effect but also to another output jack.

For example if you insert FX2 into track 1, the FX2 bus will not be used (it will be vacant). In this situation if you set the track 2 "FX2 SW" to "Pst," the track 2 signal will be sent to the FX2 bus, but it will not be sent to the effect itself (FX2). Since the signal of the FX bus can be assigned to the outputs Digital out 1/2, AUX out A/B, Master, and Monitor, you can make settings so that the signal of each track is sent from separate outputs. In other words if the effect (FX2) is inserted, you can use the unused FX bus (FX2) as an AUX bus.

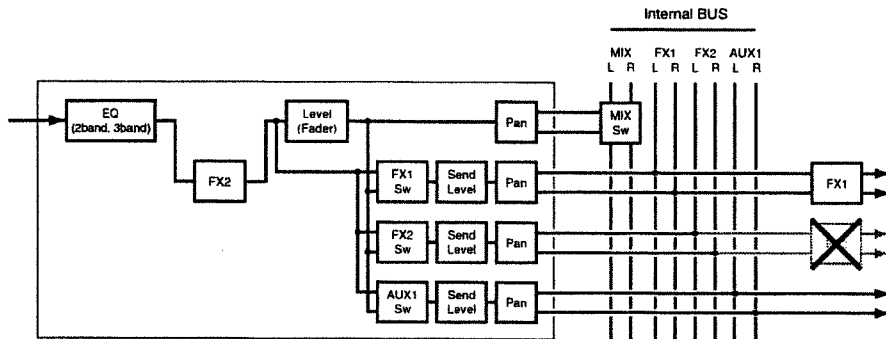

Using Effects (When VS8F-2s are Installed)

Using Effects (When VS8F-2s are Installed)

Applying an Insertion-Type Effect During Recording

When recording electric guitar or vocals etc., it is common to insert an effect such as Guitar Multi or Vocal Multi. Here we will describe how you can connect an electric guitar to the GUITAR (Hi-Z) jack, apply an effect (FX2), and record it on track 1.

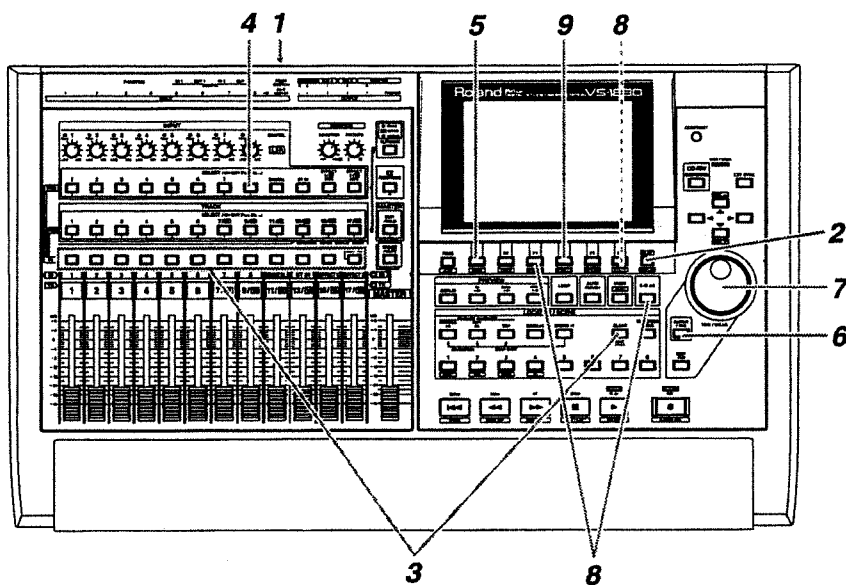

- 1 Connect an electric guitar to the GUITAR (Hi-Z) jack.
- 2 Press [PLAY (DISPLAY)].
- 3 Hold down a [STATUS] button (of any track) and press [CLEAR].
- 4 Press the [SELECT] button of the channel to which you wish to apply the effect. For this example, press the input channel 8 [SELECT] button. [SELECT] will light, and the Input Mixer display will appear.
- 5 Press [F2 (FX2In)]. If [F2] does not show "FX2In," first press [PAGE] so that "FX2In" appears, and then press [F2 (FX2In)].

MEMO

This will clear any existing input and/or track routing assignments.

Using Effects (When VS8F-2s are Installed)

6 Press [YES].

7 Use the TIME/VALUE dial to select how effect 2 will be inserted. For this example, select "Ins."

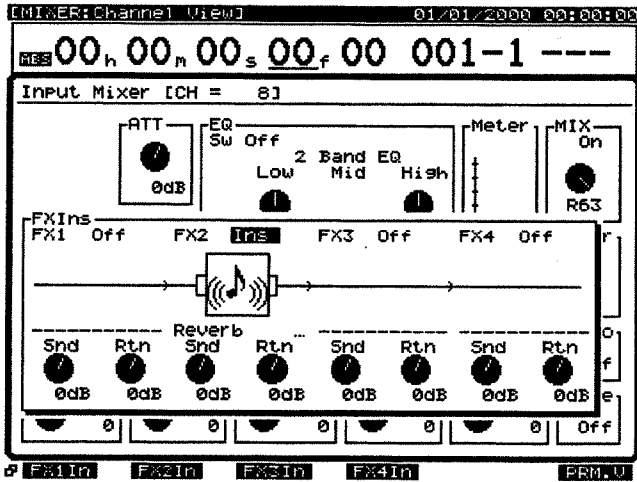

NOTE

If the display indicates "FX2--," the effect (FX2) is inserted into another channel, and therefore cannot be inserted into this channel (p. 95). Either turn off effect insertion for the channel that is using the effect, or insert a different effect into this channel.

Using Effects (When VS8F-2s are Installed)

8 Hold down [SHIFT] and press [F3 (FX A)]. The Effect A menu will appear. If the Effect A menu does not appear, press [F6 (EXIT)].

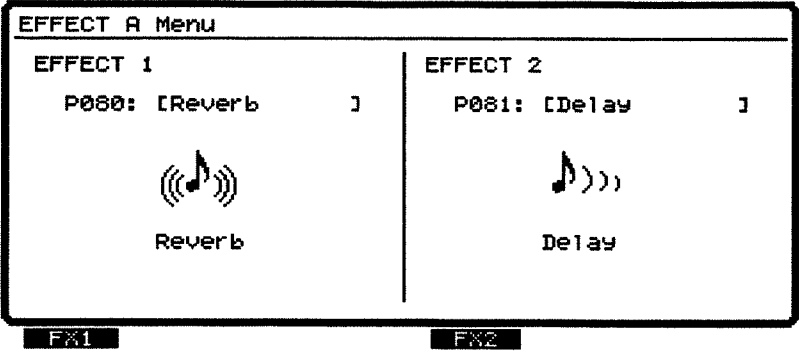

9 Press [F4 (FX2)].

Using Effects (When VS8F-2s are Installed)

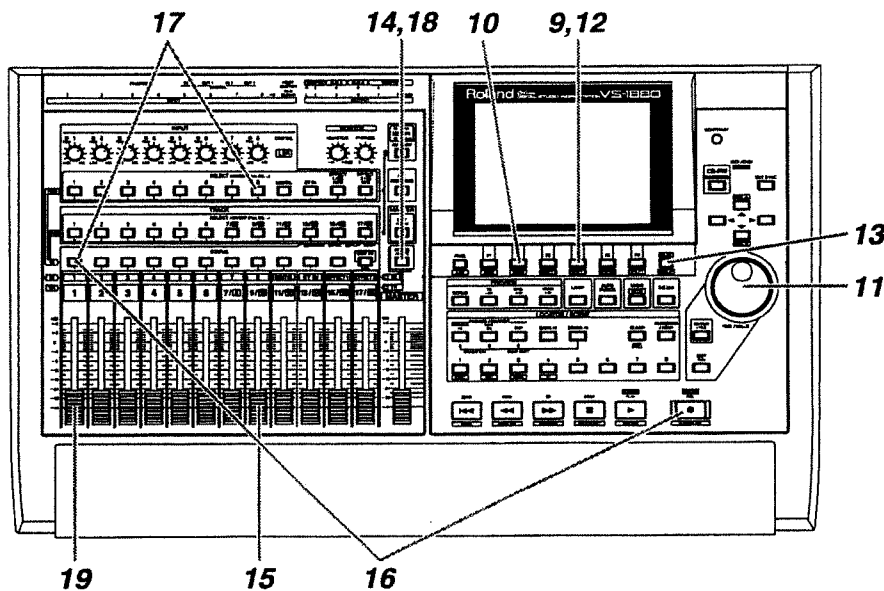

10 Select an effect. Press [F2 (Sel)]. A list of effects will appear.

11 Use the TIME/VALUE dial to move the cursor to the effect that you wish to use. For this example, select an effect such as "P041 GT:Rock Lead."

EFFECT2 Select Cur P081 : [Delay]	
P040 : [VO: Bull Horn]	P050 : [GT: Liver Pool]
P041 : [GT: Rock Lead]	P051 : [GT: Country]
P042 : [GT: LA Lead]	P052 : [GA: JazChorus]
P043 : [GT: MetalLead]	P053 : [GA: CleanTwin]
P044 : [GT: Metal Jet]	P054 : [GA: Vin. Tweed]
P045 : [GT: CleanRthm]	P055 : [GA: BluesDrv.]
P046 : [GT: DledClean]	P056 : [GA: MatchLead]
P047 : [GT: Delay Rif]	P057 : [GA: StudioCmb]
P048 : [GT: Acoustic]	P058 : [GA: JMP-Stack]
P049 : [GT: BluesDrv.]	P059 : [GA: SLIN Lead]

12 After you have selected an effect, press [F4 (Exec)].

13 Press [PLAY (DISPLAY)] to return to the original display screen.

14 Press [FADER] so that the IN (input) indicator is lit.

Using Effects (When VS8F-2s are Installed)

15 Raise and lower channel fader 8, and verify that the source volume changes. The input channel fader is used to make fine adjustments in the recording level. Set it to an appropriate position.

16 Select the track that you wish to record. Hold down [REC], and press the [STATUS] button of the track that you wish to record. For this example, hold down [REC] and press the track 1 [STATUS] button. [STATUS] will blink red.

17 Select the source that will be recorded on the track. Hold down the [STATUS] button of the track that you wish to record, and press the [SELECT] button of the input channel that you wish to assign as the source. For this example, hold down the track 1 [STATUS] button, and press the input channel 8 [SELECT] button so it begins to blink.

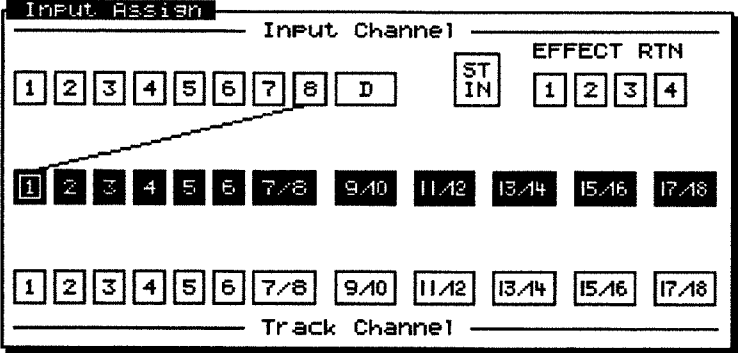

18 Press [FADER] so that the TR (track) indicator is lit.

19 Raise and lower channel fader 1, and verify that the volume changes. The track channel fader is used for monitoring. It does not affect the recording level. You can record even if no sound is heard. Set the fader to a comfortable level for listening.

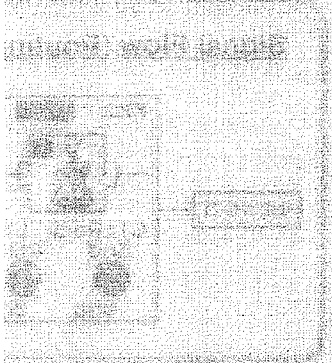

MEMO
At this time, the sound of input channel 8 will no longer be output directly from master out.

Using Effects (When VS8F-2s are Installed)

Using Effects (When VS8F-2s are Installed)

20

As described in "Recording On a Track" (p. 42), record your performance and listen to the result.

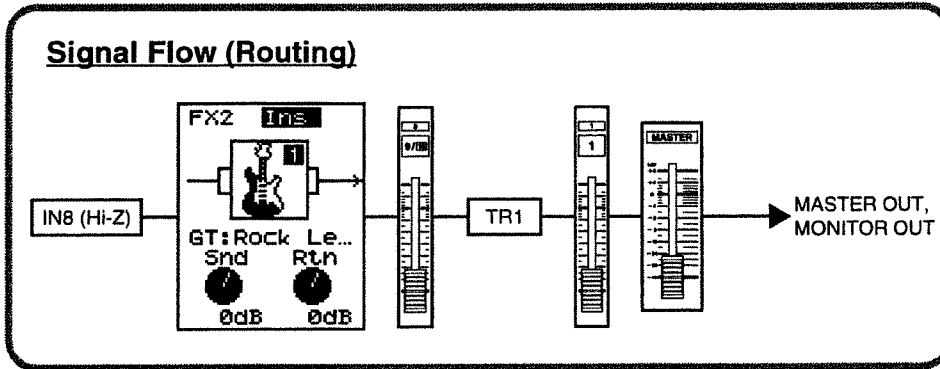

Add Finishing Touches to Your Song

Here we will explain the procedure by which a recorded performance can be mixed down on the VS-1880 to a two-track stereo master, and then recorded as an original audio CD.

Combining the Performances of Multiple Tracks (Track Bouncing)

Performances that are recorded on two or more tracks can be mixed, and re-recorded on one or two other vacant tracks. This process is called **Track Bouncing**, and is convenient when you are beginning to run out of vacant tracks.

In order to create an original audio CD, you can specify two of the VS-1880's tracks as the left track and right track, and write them to a CD-R disc. A performance that has not yet been mixed down must be mixed down (bounced) to 2-track stereo.

Here we will demonstrate an example of mixing down a performance that was recorded on tracks 1–6, and applying reverb (FX1) to the entire song as we re-record it to tracks 7 and 8 in stereo.

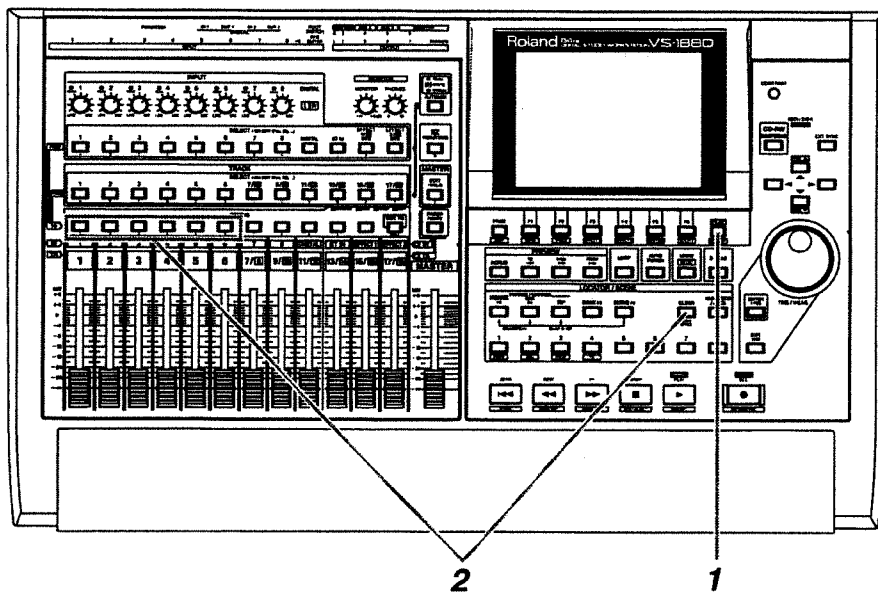

- 1** Press [PLAY (DISPLAY)].
- 2** Hold down a [STATUS] button (of any track) and press [CLEAR].



In order to create an original audio CD, you will need the Roland CD recorder (sold separately).



If a VS8F-2 effect expansion board has not been installed, it will not be possible to use the internal effects.



This will clear any existing input and/or track routing assignments.

Add Finishing Touches to Your Song

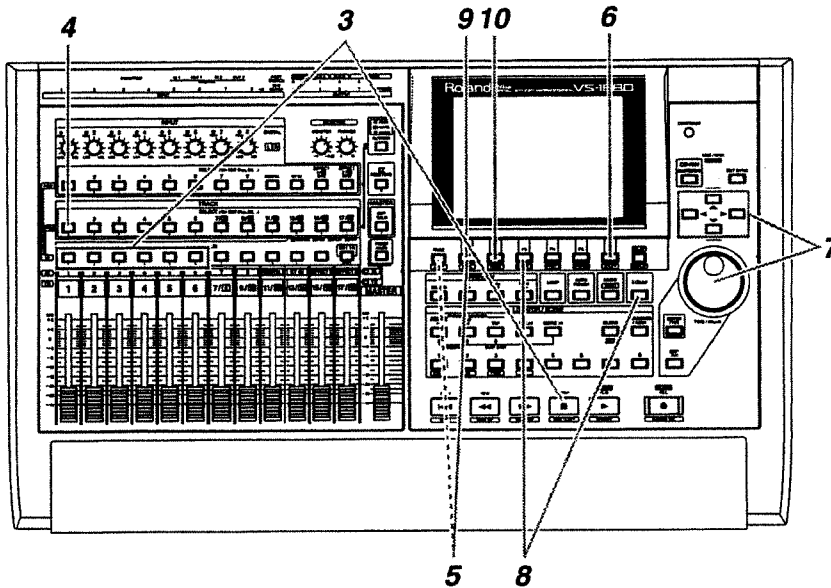

NOTE

If a VS8F-2 effect expansion board has not been installed, it will not be possible to use the internal effects.

- 3** Select the track that you wish to playback. Hold down [STOP] and press the [STATUS] button of the tracks that you wish to playback. For this example, hold down [STOP] and press the track 1-6 [STATUS] buttons. [STATUS] will light green.
- 4** Press the [SELECT] button of the track channel(s) to which you wish to apply the effect. For this example, press the track channel 1 [SELECT] button. [SELECT] will light, and the Track Mixer display will appear.
- 5** Press [F1 (FX1)]. If [F1] does not show "FX1," first press [PAGE] so that "FX1" appears, and then press [F1 (FX1)].
- 6** Press [F6 (PRM.V)]. A list of the effect settings for each track will appear.
- 7** Use [▲] [▼] [◀] [▶] to move the cursor, and use the TIME/VALUE dial to set the effect switch to either "Pre" or "Pst" for the track to which you wish to apply the effect. For this example, select "Pst" so that the effect will be applied to the sound that has passed through the channel fader.

Add Finishing Touches to Your Song

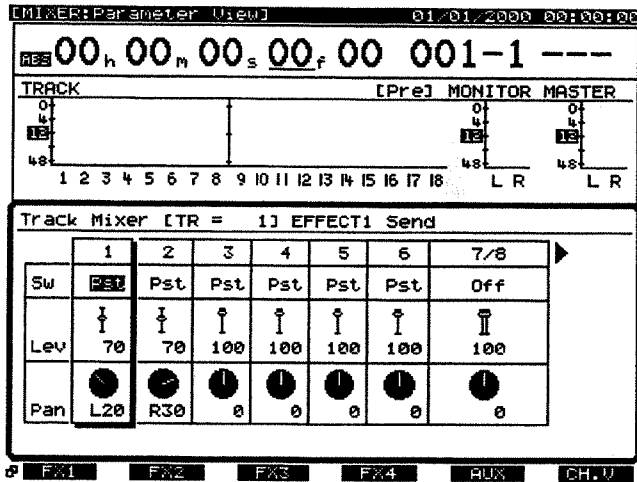

Be sure to turn off the effect switch of track channels 7 and 8.

- 8** Hold down [SHIFT] and press [F3 (FX A)]. The Effect A menu will appear.

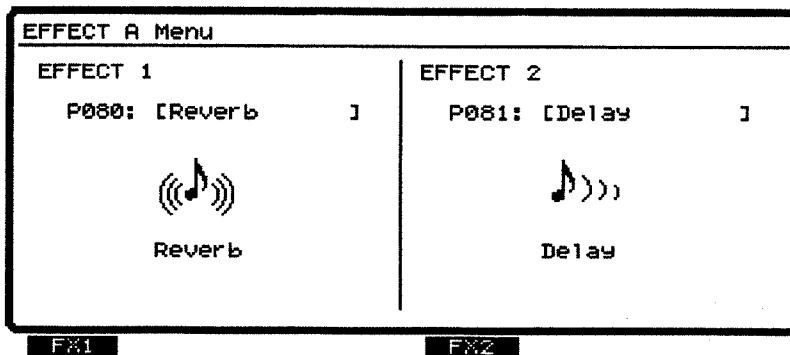

- 9** Press [F1 (FX1)].

- 10** Select an effect. Press [F2 (Sel)]. A list of effects will appear.

Add Finishing Touches to Your Song

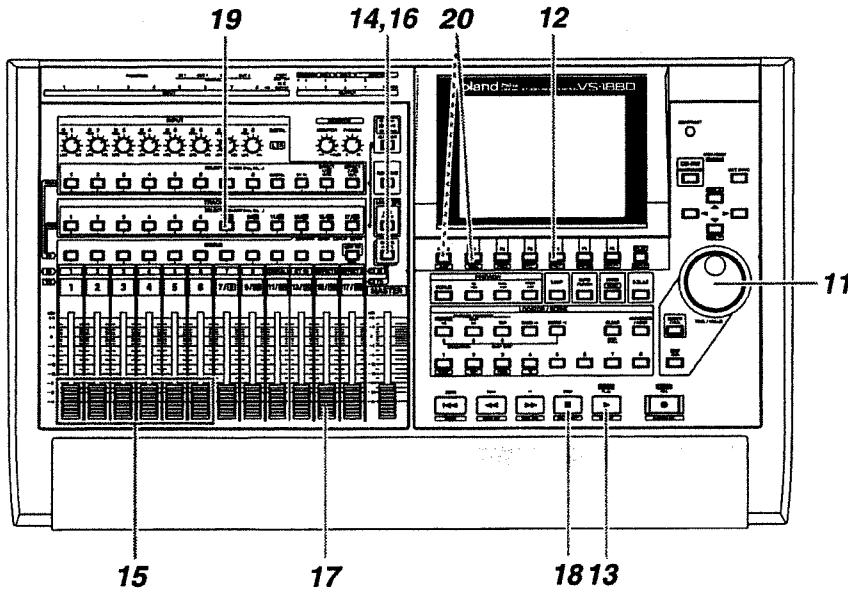

11

Use the TIME/VALUE dial to move the cursor to the effect that you wish to use. For this example, select an effect such as "P000 RV:LargeHall."

EFFECT1 Select	Cur	P000 :[Reverb]
P000	:[RV:LargeHall]	P010	:[RV:Vocal P1t]
P001	:[RV:SmallHall]	P011	:[RV:Soft Amb.]
P002	:[RV:Strings]	P012	:[RV:Room Amb.]
P003	:[RV:PianoHall]	P013	:[RV:Cathedral]
P004	:[RV:Orch Room]	P014	:[RV:Long Cave]
P005	:[RV:VocalRoom]	P015	:[RV:GarageDr.]
P006	:[RV:MediumRM]	P016	:[RV:Rock Kick]
P007	:[RV:LargeRoom]	P017	:[RV:RockShare]
P008	:[RV:CoolPlate]	P018	:[RV:Br iteGate]
P009	:[RV:Short P1t]	P019	:[RV:Fat Gate]

12

After you have selected an effect, press [F4 (Exec)].

13

Press [PLAY]. The song will play back.

14

Press [FADER] so that the TR (track) indicator is lit.

15

Use channel faders 1–6 to adjust the volume balance of the tracks. At this time, the sound that you are monitoring (volume levels and pan) will be recorded on tracks 7 and 8 just

Add Finishing Touches to Your Song

as you hear it. It is best to record at as high a level as possible without allowing the sound to distort.

- 16 Press [FADER] so that the IN (input) indicator is lit.
- 17 Use channel fader 15/16 (EFFECT1) to adjust the effect return level. At this time, the sound that you are monitoring will be recorded to tracks 7 and 8 exactly as you hear it.
- 18 When you finish adjusting the volume, press [STOP]. The song will stop.
- 19 Press the [SELECT] button for one of the track channels you wish to record (whether left or right does not matter). For this example, press the track channel 7/8 [SELECT] button. The Track Mixer display will appear.
- 20 Press [F1 (Link)]. If [F1] does not show "Link," first press [PAGE] so that "Link" appears, and then press [F1 (Link)].

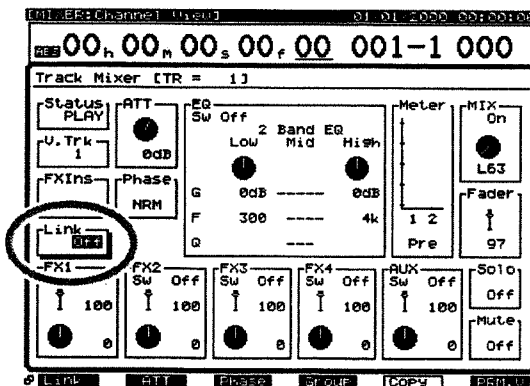

Add Finishing Touches to Your Song

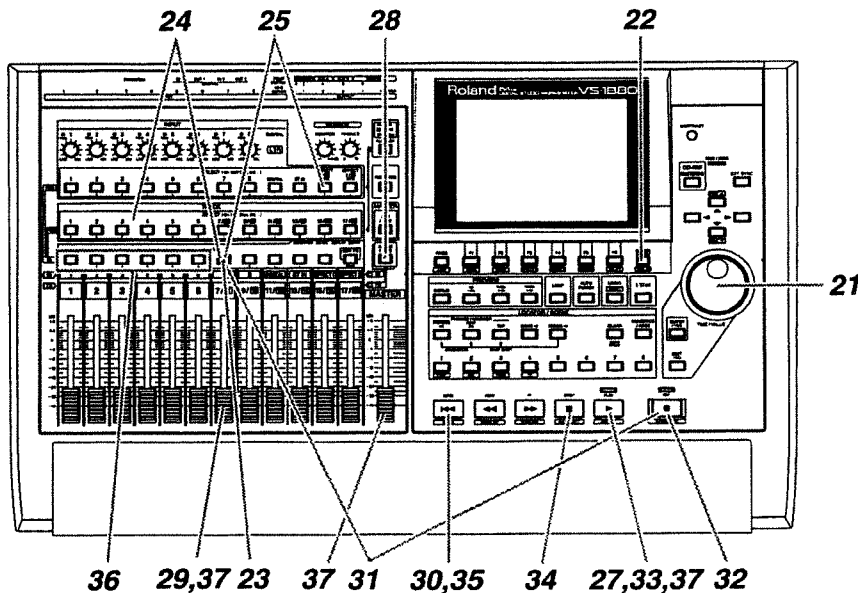

- 21** Use the TIME/VALUE dial to turn Channel Link "On."
- 22** Press [PLAY (DISPLAY)] to return to the original display screen.
- 23** Press the track 7/8 [STATUS] button so that the indicator lights orange.
- 24** Assign the playback tracks to the recording tracks. Hold down the track 7/8 [STATUS] button, and press the [SELECT] buttons of track channels 1-6. [SELECT] will blink.
- 25** Assign the effect return to the recording tracks. Hold down the track 7/8 [STATUS] button, and press the input channel [EFFECT 1 RTN] button. [EFFECT 1 RTN] will blink.
- 26** With these settings, tracks 1-6 and the effect return can be monitored on track channels 7 and 8.
- 27** Press [PLAY]. The song will play back.

MEMO

At this time, the sounds of track 1-6 will no longer be output directly from master out.

At this time, FX1 will no longer be output directly from the master out.

Add Finishing Touches to Your Song

- 28** Press [FADER] so that the TR (track) indicator is lit.
- 29** Raise and lower channel fader 7/8 and verify that the volume of the recording tracks (7 and 8) changes. Track channel fader 7 is used for monitoring. It does not affect the recording level. You can record even if you hear no sound. Adjust the volume to a comfortable listening level.
- 30** Press [ZERO]. You will return to the beginning of the song.
- 31** Hold down [REC] and press the [STATUS] button of the track that you wish to record. For this example, hold down [REC] and press the track 7/8 [STATUS] button. [STATUS] will blink red.
- 32** Press [REC]. The [REC] indicator will blink red.
- 33** Press [PLAY]. The [PLAY] indicator will light green, and recording will begin.
- 34** When you finish recording, press [STOP]. The song will stop.
- 35** Listen to the recorded result. Press [ZERO]. You will return to the beginning of the song.
- 36** Mute tracks 1–6 (so that they will not produce sound). Press the track 1–6 [STATUS] buttons so they are not lit.
- 37** Press [PLAY]. The song will play back. Use channel fader 7 and the master fader to adjust the volume to a comfortable listening level.

Add Finishing Touches to Your Song

Signal Flow (Routing)

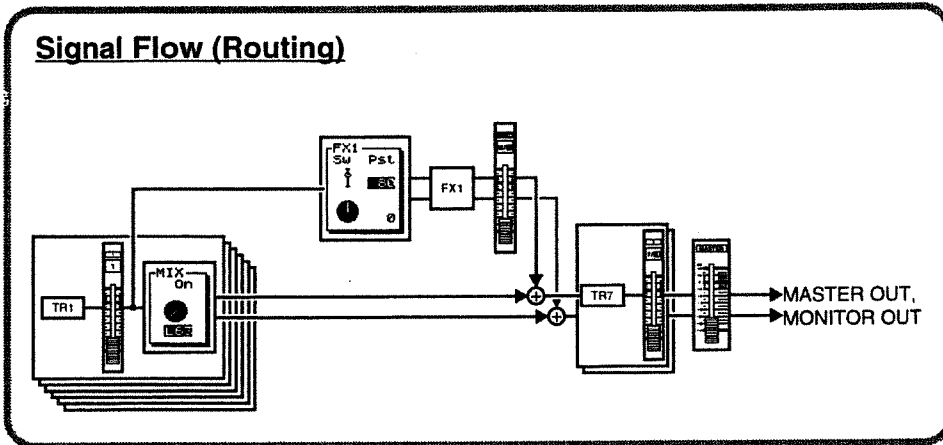

Erasing an Unwanted Portion (Track Cut)

Song data that was track-bounced will be recorded to the CD-R disc starting from "00h00m00s00" of that track and ending at the end of the song (song end). This means that if there are silent portions at the beginning or end of the performance, the capacity of the CD-R disc will be wasted. To avoid this, you can erase unwanted portions.

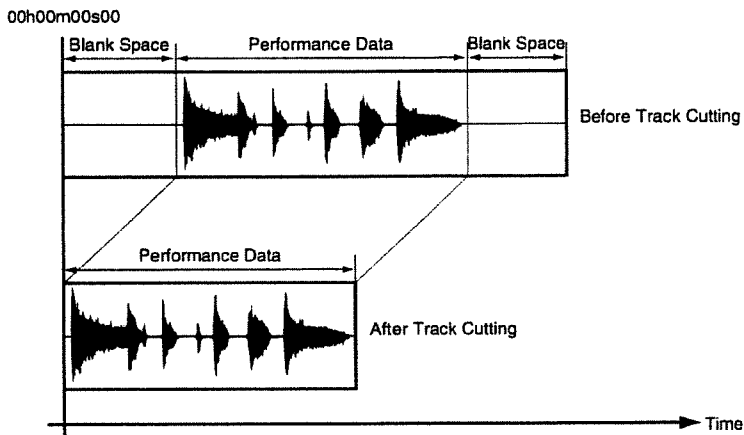

For details refer to "Track Cut" (Owner's Manual p.143).

Selecting the Portion that will be Written to the CD-R Disc

To simplify the task of assembling the track cuts, you can select a desired area, and register it in the Locator function. For details on registering / deleting Locator entries, refer to "Storing a Time Location" (Owner's Manual p.36).

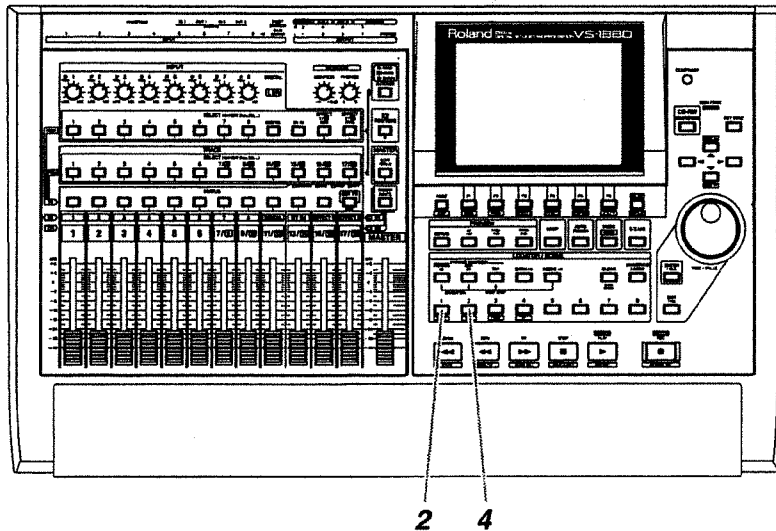

- 1** Move to the time location where you wish to begin writing.
- 2** Press LOCATOR[1]. The time will be registered in locator 1.
- 3** Move to the time location where you wish to stop writing.
- 4** Press LOCATOR[2]. The time will be registered in locator 2.

NOTE

If the LOCATOR button is already lit, a locator is already stored there. You can either select a different LOCATOR or clear the existing locator by holding [CLEAR] and pressing that LOCATOR button.

Add Finishing Touches to Your Song

Deleting an Unwanted Portion At the End of the Song

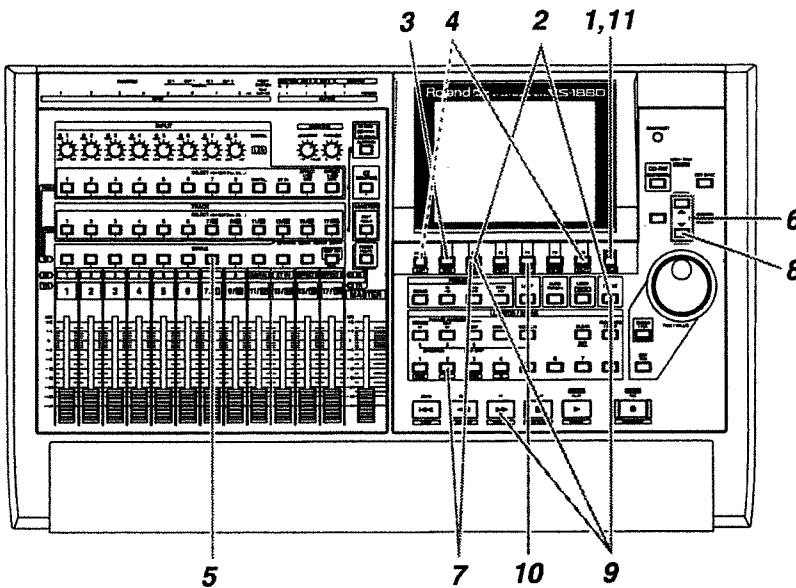

- 1 Press [PLAY (DISPLAY)].
- 2 Hold down [SHIFT] and press [F2 (TRACK)].
- 3 Press [F1 (Tr/Ph)] so that the Track Edit menu appears.

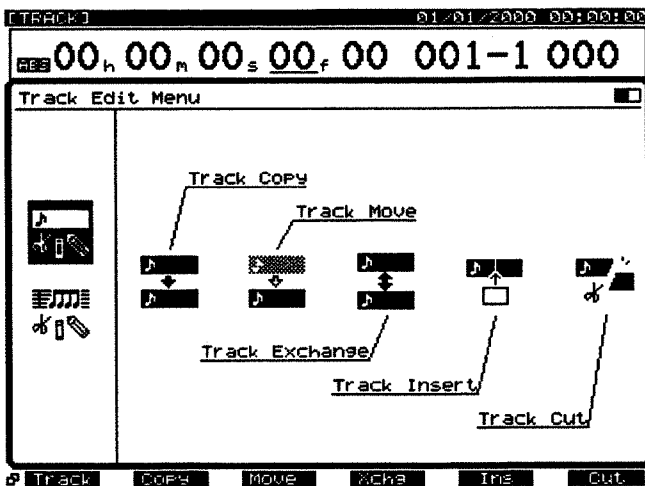

- 4 Press [F6 (Cut)]. If [F6] does not show "Cut," first press [PAGE] so that "Cut" appears, and then press [F6 (Cut)].

Add Finishing Touches to Your Song

- 5 Press the [STATUS] button of the track(s) that you wish to write to the CD. For this example, press the track 7 or 8 [STATUS] buttons. [STATUS] will light red.
- 6 Use [▲] [▼] to move the cursor to "START."
- 7 Specify the starting location of the area that will be deleted. Press LOCATOR[2] and then press [F2 (NOW)].
- 8 Press [▼]. The cursor will move to "END."
- 9 Specify the end location of the area that will be deleted. Hold down [SHIFT] and press [SONG END (FF)], and then press [F2 (NOW)].

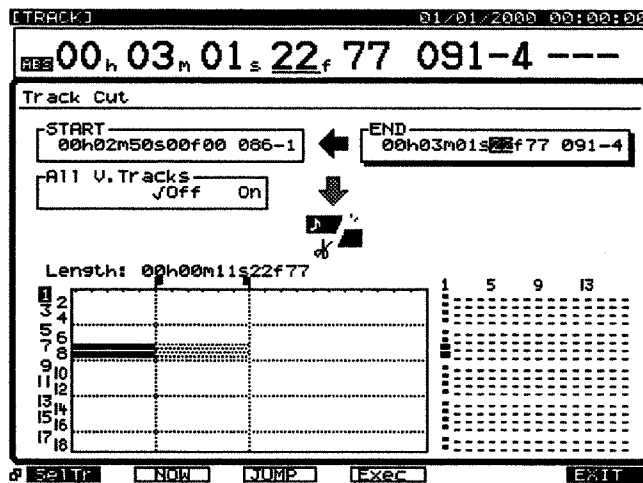

- 10 Press [F4 (Exec)]. The Track Cut operation will be executed.
- 11 When the Track Cut operation has been completed, the display will indicate "Complete." Press [PLAY (DISPLAY)].

Add Finishing Touches to Your Song

Deleting an Unwanted Portion At the Beginning of the Song

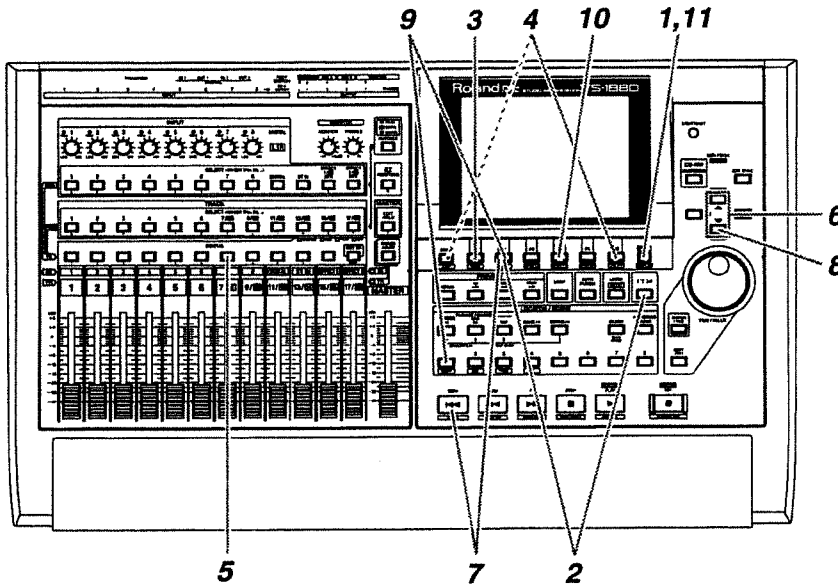

- 1** Press [PLAY (DISPLAY)].
- 2** Hold down [SHIFT] and press [F2 (TRACK)].
- 3** Press [F1 (Tr/Ph)] so that the Track Edit menu appears.

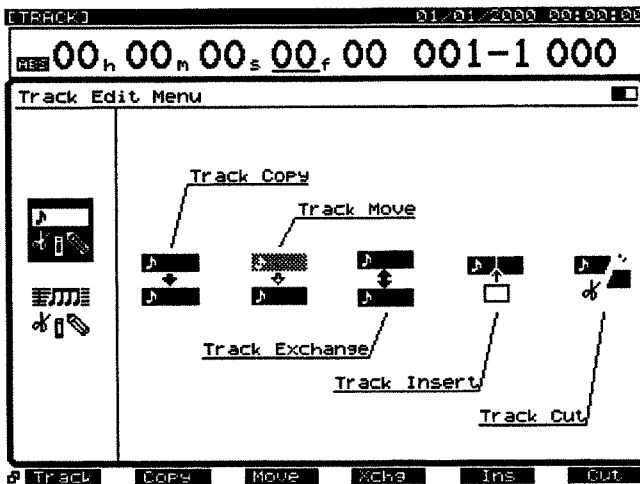

- 4** Press [F6 (Cut)]. If [F6] does not show "Cut," first press [PAGE] so that "Cut" appears, and then press [F6 (Cut)].

Add Finishing Touches to Your Song

- 5 Press the [STATUS] button of the track(s) that you wish to write to the CD. For this example, press the track 7 or 8 [STATUS] buttons. [STATUS] will light red.
- 6 Use [▲] [▼] to move the cursor to "START."
- 7 Specify the beginning of the area to be deleted. Press [ZERO], and then press [F2 (NOW)].
- 8 Press [▼]. The cursor will move to "END."
- 9 Specify the end of the area to be deleted. Press LOCATOR[1], and then press [F2 (NOW)].

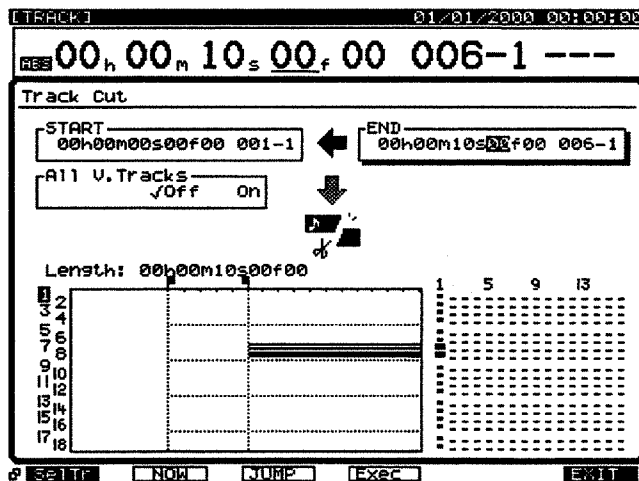

- 10 Press [F4 (Exec)]. The Track Cut operation will be executed.
- 11 When the Track Cut operation is completed, the display will indicate "Complete." Press [PLAY (DISPLAY)].

Add Finishing Touches to Your Song

Mixing down to the mastering tracks (Mastering Room)

Here's how to select the mastering tracks, and perform a mixdown.

Mixing down to the mastering tracks (MST TR)

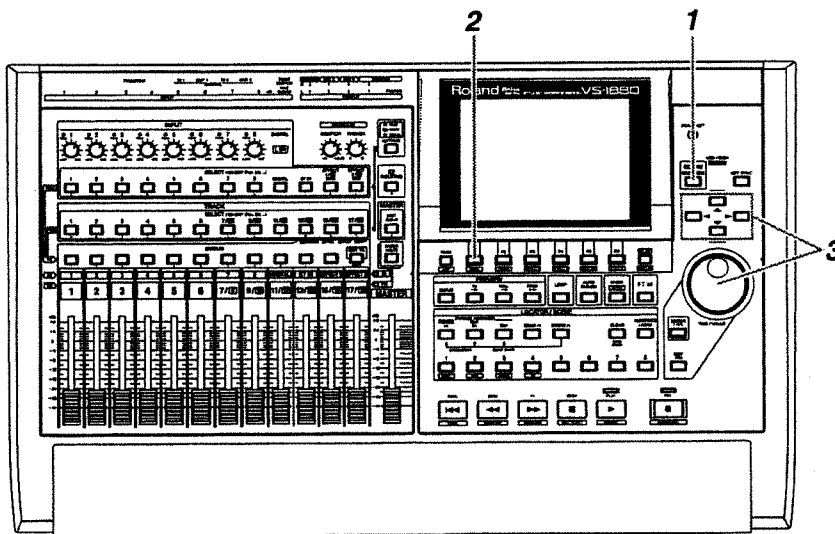

1 Press [CD-RW (MASTERING)].

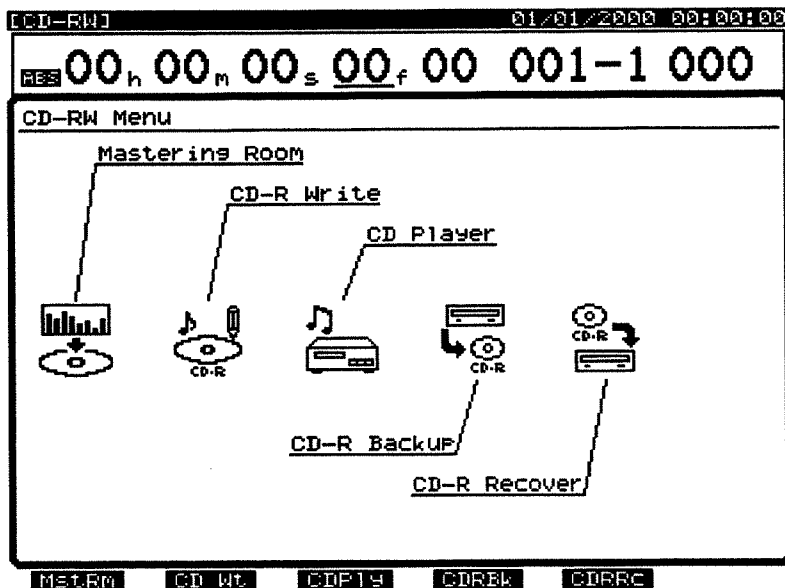

2 Press [F1 (MstRm)].

NOTE

The operation of playing back 16 tracks while you mixdown to the mastering tracks (MST TR) is significantly affected by the speed of the hard disk. For this reason, depending on the structure of the song data (sampling rate and recording mode, or when punch-in/out is used frequently, etc.), or depending on the drive that you use, the display may indicate "Drive Busy," and the operation may not take place correctly. *In order to take full advantage of the VS-1880's potential, such as the number of tracks that can be recorded/played simultaneously, and the recording capacity, we recommend that you use a hard disk which capacity is 2.1 GB or more.*

3

Press [▲], [▼], [◀], or [▶] to move the cursor. Use the TIME/VALUE dial to specify the value for each parameter.

Sw (mastering track switch)

Choose whether to make tracks 17 and 18 the mastering tracks. For this example, select "On."

Off: The VS-1880 is used as an 18-track recorder.

On: Tracks 17 and 18 are used as mastering tracks. At this time, you cannot play back tracks 1 through 16 and track 17/18 at the same time.

Status (mastering track status)

Rec: Play back tracks 1–16 while recording them to the mastering tracks.

Play: Play back the mastering tracks. The sound of tracks 1–16 will not be output from the MASTER jacks.

V.Trk (V-Track)

Select the two V-tracks (L and R) that will be assigned as mastering tracks. When a new song is created, V-track 16 of tracks 17/18 (17-16, 18-16) will be assigned as the mastering tracks.

Marker

If this is turned "On," a track number marker will automatically be assigned to the beginning of the phrase that is mixed down. Normally you will set this "On."

MEMO

For details on the signal flow (routing) at this time, refer to **Signal Flow (Routing)** (p. 119).

Add Finishing Touches to Your Song

After Rec (after recording)

Specify the time location of the mastering track to which the mixdown will be recorded. When creating an original audio CD, it is usually best to select "to ZERO."

- to ZERO:** Place the data starting at 00h00m00s00f
- to last Phrs:0S:** Place the data after the end of the last phrase in the mastering tracks.
- to last Phrs:2S:** Place the data two seconds after the end of the last phrase in the mastering tracks.
- to last Phrs:4S:** Place the data four seconds after the end of the last phrase in the mastering tracks.
- Stay HERE:** Place the data at the time location at which it was actually recorded.

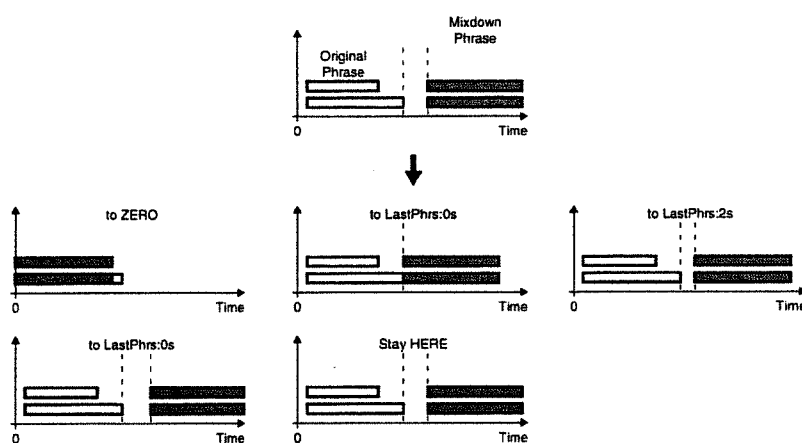

MEMO

Depending on the After Rec (After Recording) setting or on the location relative to other markers, the display may indicate "Can't Set Marker," and the track number marker may not be assigned.

CDRRecMode (CD-R recording mode)

This is the switch for setting whether to record the mastering tracks in CDR mode.

- Off:** The mastering tracks are recorded using the recording mode of the present song.
- On:** The mastering tracks are recorded in CDR mode. This allows you to skip the step of creating an image file when writing to the CD, so it can shorten the write time.

FXIns (effects insert)

Determines which effects are to be inserted in the mastering tracks.

Off: None inserted.

1234: Press [ENTER], and select the effects you want to insert. Numbers corresponding to the effects you use are displayed.

FXIns

Add Finishing Touches to Your Song

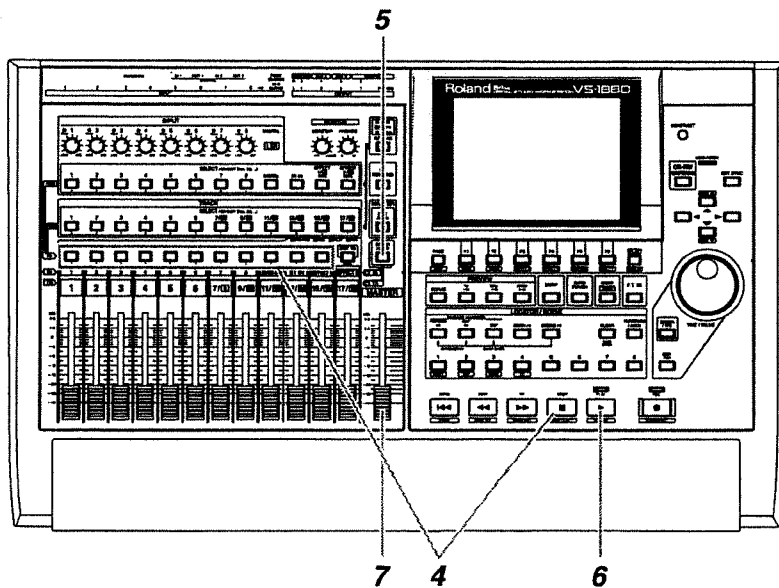

- 4** Hold down [STOP], and press the [STATUS] button for all tracks (1-15/16) that you wish to mixdown. The STATUS indicators will light green.

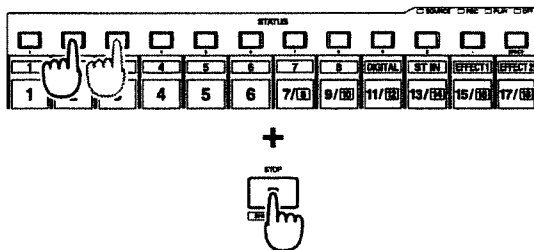

- 5** Press [FADER] so that the TR (track) indicator lights.



- 6** Press [PLAY]. The song will play back.

- 7** Raise and lower the master fader, and verify that the volume of each track changes.



You cannot record the sound on tracks 17 and 18 to the mastering tracks.



The sound that passes through the master fader will be recorded on the mastering tracks. **In order to record at the optimal audio quality, you should normally set this to the 0 dB position.**

Add Finishing Touches to Your Song

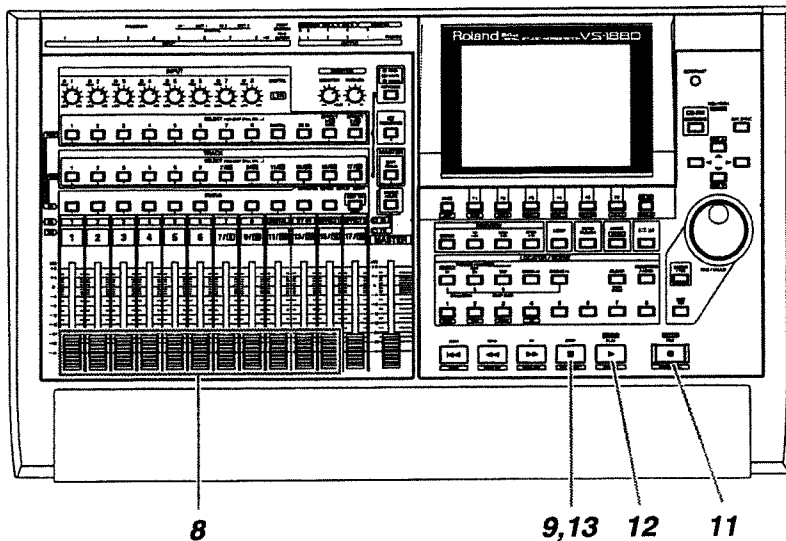

- 8** Use the channel faders (1–15/16) to adjust the volume balance of each track. At this time the sound that is being output from the MASTER jacks (volume levels, panning) will be recorded to the mastering tracks. It is best to set the volume as high as possible without causing the volume to distort.
- 9** When you have finished adjusting the volume, press [STOP].
- 10** Move to the location at which you wish to begin the mixdown (such as 00h00m00s00f).
- 11** Press [REC]. The REC indicator will light in red.
- 12** Press [PLAY]. The PLAY indicator will light in green, and recording will begin.

13 When you finish recording, press [STOP].

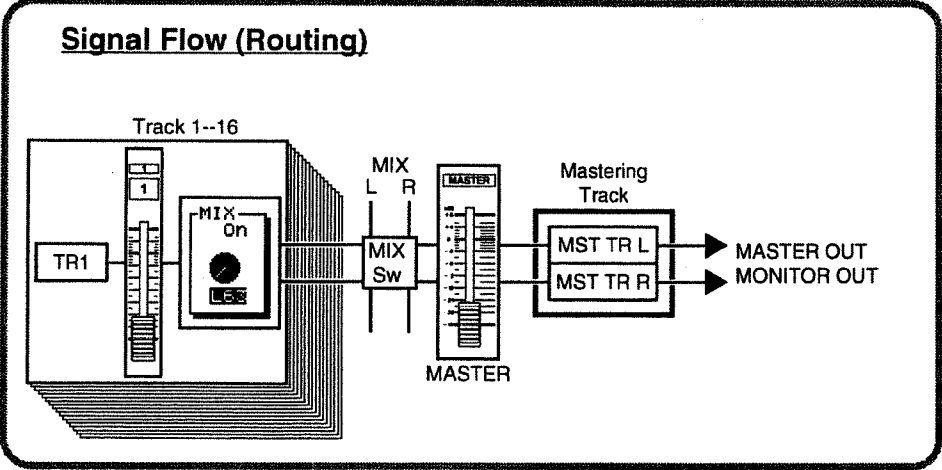

Add Finishing Touches to Your Song

Playing back the mastering tracks

Here's how you can verify the audio that was mixed down to the mastering tracks. **Tracks 1–16 will not be played back.**

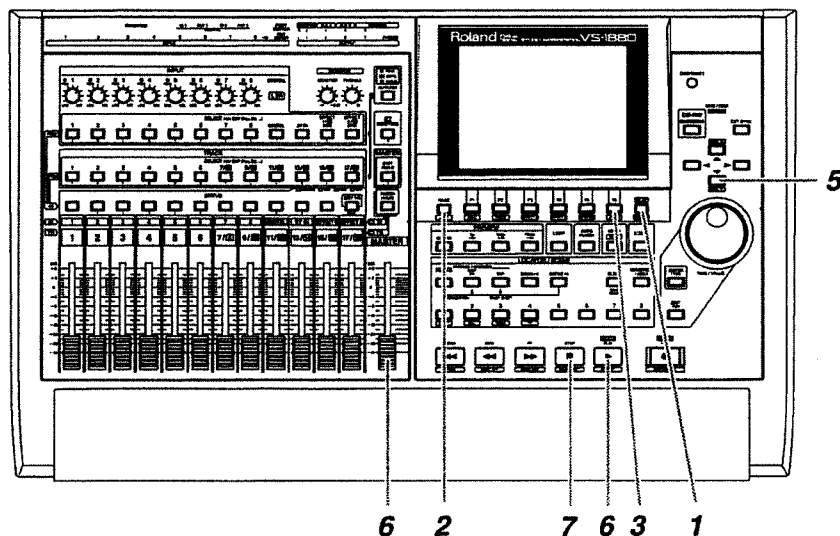

- 1 Press [PLAY (DISPLAY)].
- 2 Press [PAGE] so that [F6] indicates "M→***" (** is either Rec, Ply, or Off).
- 3 Press [F6] to cycle between "M→Rec" → "M→Play" → "M→Off." This allows you to change the mastering track switch and mastering track status at the same time. The current status of the mastering tracks can be viewed in the level meter in the display. For this example, select "M→Off" (playback status: pressing [F6] once again will select Off).

MEMO

For details on the signal flow at this time, refer to **Signal Flow (Routing)** (p. 121).

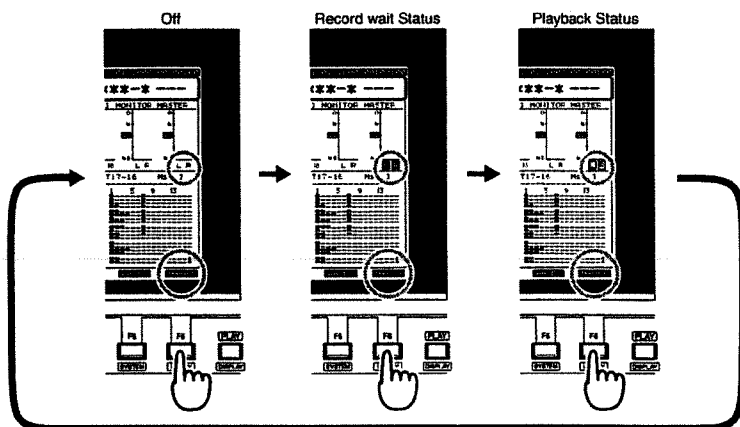

Add Finishing Touches to Your Song

Parameter Table (Mastering Track)

	Mastering Track Switch	Mastering Track Status
Off	Off	Rec
Record wait Status	On	Rec
Playback Status	On	Play

- 4 Move to the location at which you started the mixdown.
- 5 Press [▼] so that you can view the playlist of the mastering tracks.
- 6 Press [PLAY]. The mastering tracks will play back. Use the master fader to adjust the volume to a comfortable listening level.

At this time, the function buttons will function as follows (Owner's Manual, p.176).

- [F1 (ZOOM+)]:Enlarges the playlist in the track direction (three levels).
- [F2 (ZOOM-)]:Reduces the playlist in the track direction (three levels).
- [F3 (←→)]:Enlarges the playlist in the time direction (five levels).
- [F4 (→←)]:Reduces the playlist in the time direction (five levels).
- [F5 (WAVE)]:Display the sound level (waveform) that is recorded in the tracks.

- 7 When playback ends, press [STOP].

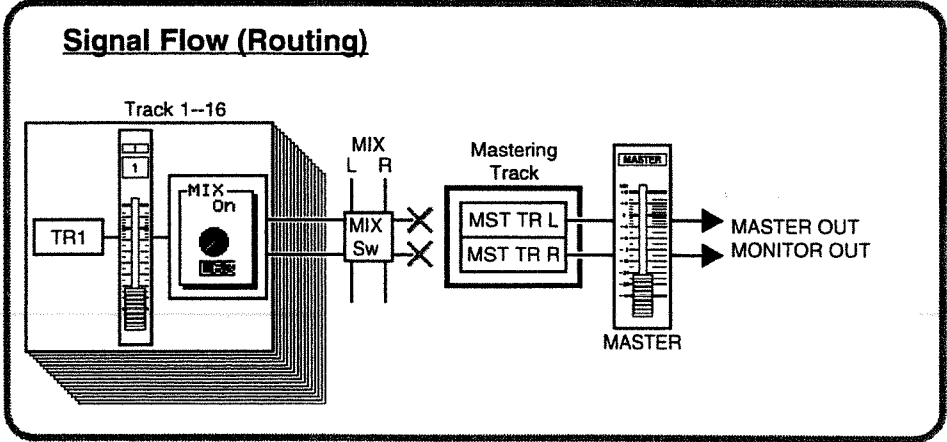

MEMO

If the bottom line of the display is surrounded by a heavy line, you can also use the TIME/VALUE dial to check the playlist of the mastering tracks.

NOTE

The tracks 17/18 fader has no effect on the volume level of the mastering tracks.

Add Finishing Touches to Your Song

Add Finishing Touches to Your Song

Mixing down while inserting effects

If a separately sold VS8F-2 effect expansion board is installed, you can insert effects while you mixdown.

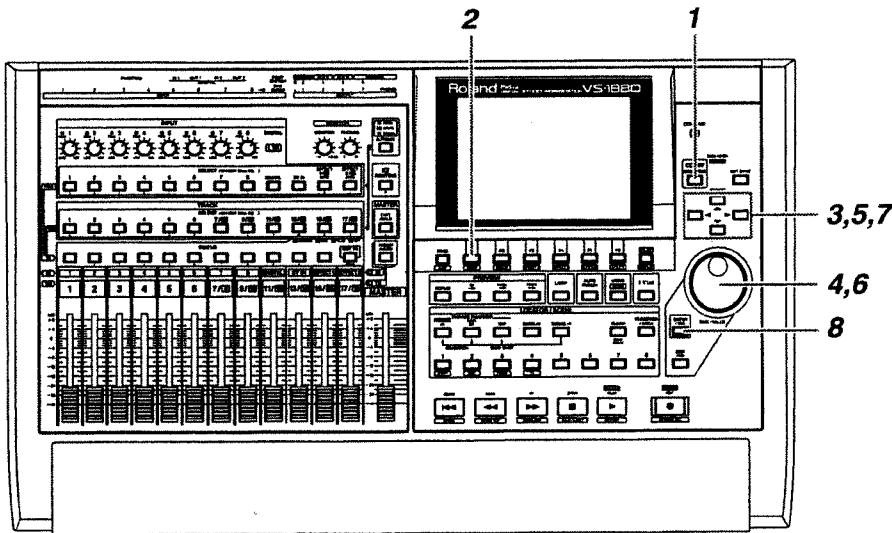

- 1 Press [CD-RW (MASTERING)].

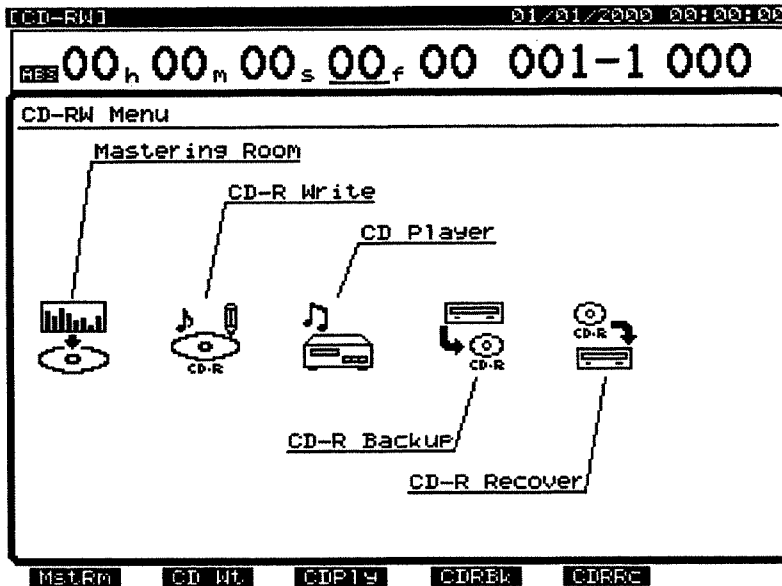

- 2 Press [F1 (MstRm)].

MEMO

While performing a mixdown, it is common to insert an effect such as a parametric equalizer or a compressor. For this example, we will insert the Mastering Tool Kit (appendices (p.79)) to adjust the overall volume balance as we mixdown.

3 Use [▲], [▼], [◀], and [▶] to move the cursor to "Sw."

4 Select the "Sw" of the mastering room. Rotate the TIME/VALUE dial. For this example, select "On."

5 Use [▲], [▼], [◀], and [▶] to move the cursor to "Status." For this example, select "Rec."

6 Select the "Status" of the mastering tracks. Rotate the TIME/VALUE dial.

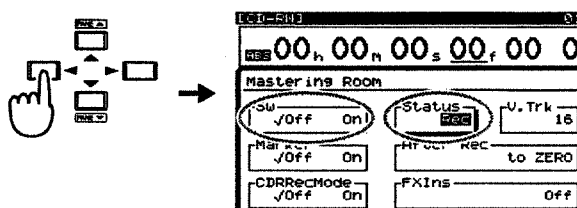

Status

Specify the status of the master tracks. For this example select "Off."

Off: The mastering tracks will not be used.

Rec: Play back tracks 1–16 and record on the mastering tracks.

Play: Play back the mastering tracks. The sound of tracks 1–16 will not be output from the MASTER jacks.

7 Use [▲], [▼], [◀], and [▶] to move the cursor to "FXIns."

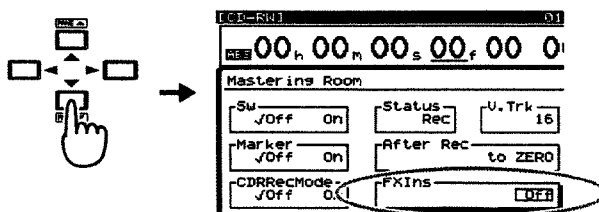

8 Press [ENTER (YES)].

MEMO

For details on the signal flow (routing) at this time, refer to **Signal Flow (Routing)** (p. 127).

Add Finishing Touches to Your Song

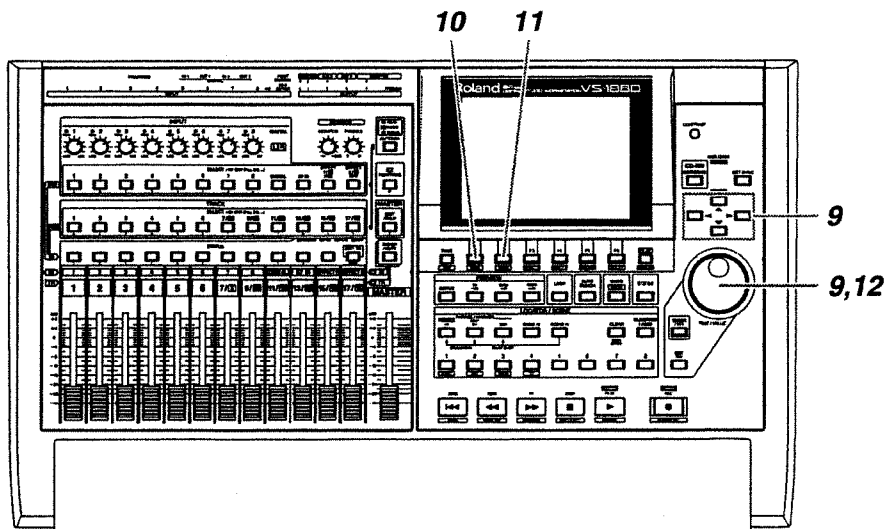

- 9 Use [▲], [▼], [◀], and [▶] to move the cursor. Use the TIME/VALUE dial to make settings.

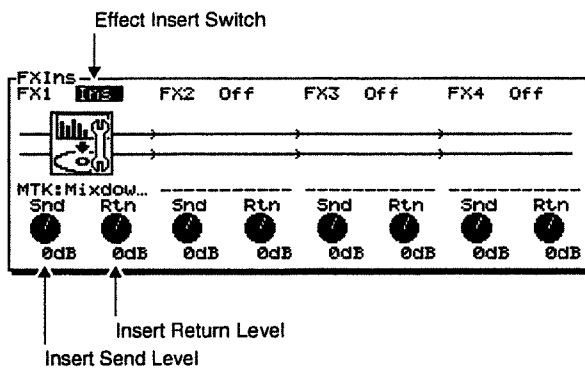

FX1 (effect insert switch 1)

Select how the effect will be connected.

Off: The effect will not be inserted.

Ins: The stereo effect will be inserted into both channels. The inserted effects are shown as icons and as patch names (up to ten characters).

Snd (effect send level)

Adjust the volume level of the signal that is sent to the insertion effect (-42–6 dB). By default, this will be “0 dB.”

Rtn (effect return level)

Adjust the volume level of the signal that is output from the insertion effect (-42–6 dB). By default, this will be “0 dB.”

Add Finishing Touches to Your Song

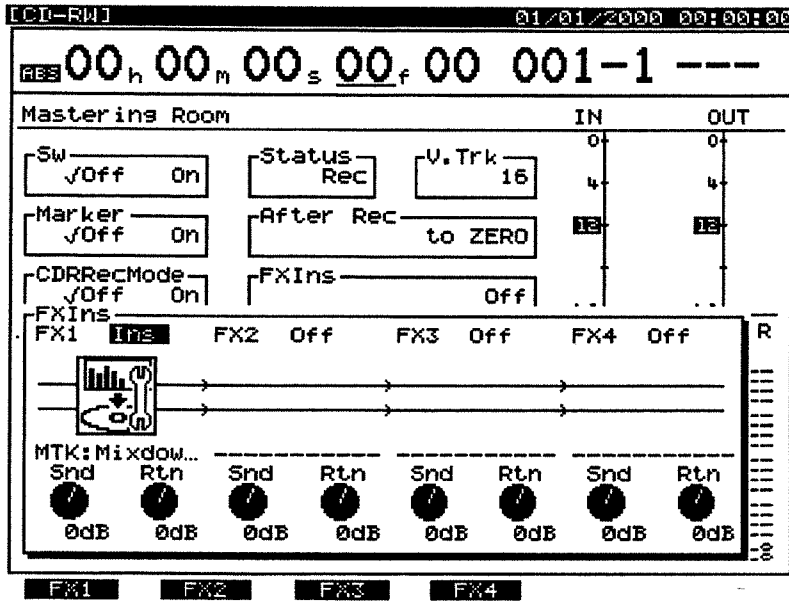

10 Press [F1 (FX1)].

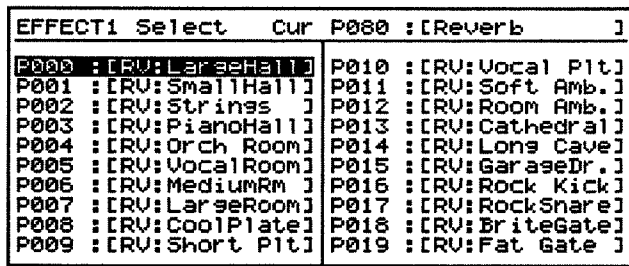

11 Press [F2 (Sel)].

12 Use the TIME/VALUE dial to move the cursor to the effect that you wish to use. For this example, select an effect such as "P210 MTK:Mixdown."

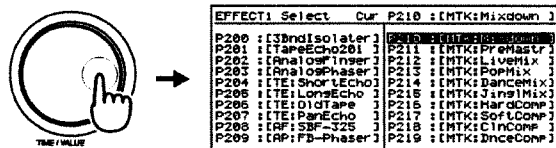

Add Finishing Touches to Your Song

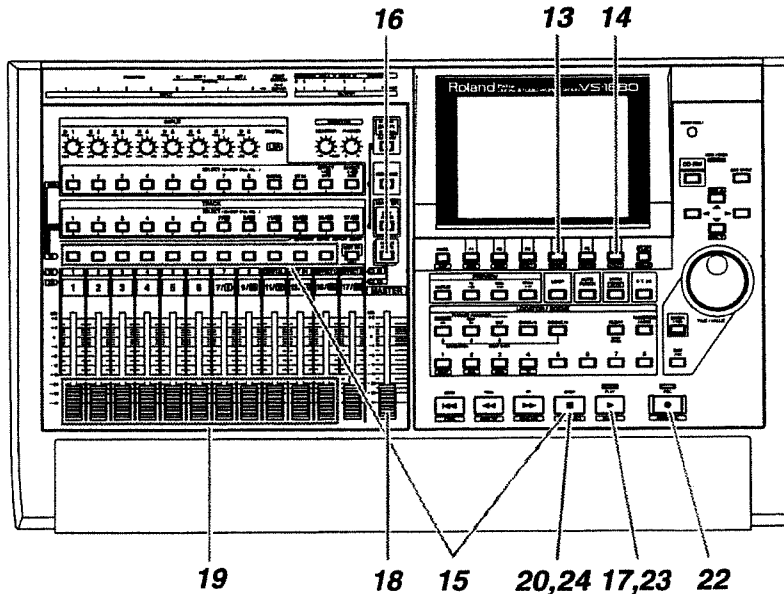

- 13** After selecting an effect, press [F4 (Exec)].
- 14** Press [F6 (EXIT)].
- 15** Hold down [STOP], and press [STATUS] for all tracks (1–15/16) that you wish to mixdown. The STATUS indicator will light in green.

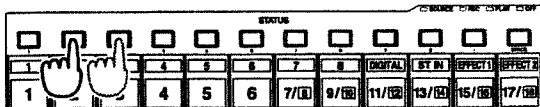

- 16** Press [FADER] so that the TR (track) indicator lights.

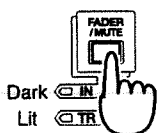

- 17** Press [PLAY]. The song will play back.

NOTE

You cannot record the sound on tracks 17 and 18 to the mastering tracks.

Add Finishing Touches to Your Song

- 18** Raise and lower the master fader, and verify that the volume of each track changes.
- 19** Use the channel faders (1–15/16) to adjust the volume balance of the tracks. At this time, the sound (volume level and pan) that is output from the MASTER jacks will be recorded “as is” to the mastering tracks. Adjust the volume to as high a level as possible without causing distortion.
- 20** When you are finished adjusting the volume, press [STOP].
- 21** Move to the time location at which you wish to begin the mixdown (e.g., 00h00m00s00f).
- 22** Press [REC]. The REC indicator will light in red.
- 23** Press [PLAY]. The PLAY indicator will light in green, and recording will begin.
- 24** When you finish recording, press [STOP].

MEMO

The sound that has passed through the master fader will be recorded on the mastering tracks. **In order to record at the optimal audio quality, you will normally set the master fader to 0 dB.**

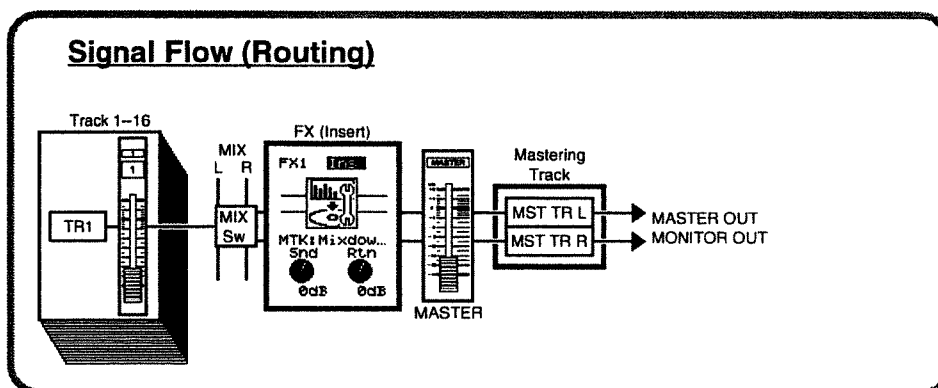

Adding Track Number Markers

By placing two or more songs one after the other in the same track, you can write these songs consecutively to the CD-R disc. In this case, you can place markers between songs to function as track numbers, just as on a pre-recorded audio CD. These track numbers will be written to the audio CD that you record on your CD-R drive.

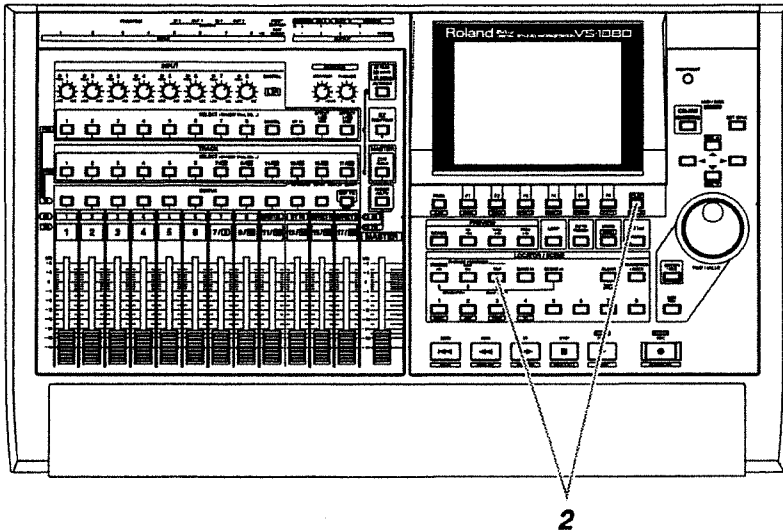

1 While listening to the song, move to the location where you wish to place a track number. You will probably find it convenient to use the Preview function or the Scrub function (Owner's Manual p.163).

2 Hold down [PLAY (DISPLAY)] and press [TAP]. A track number marker will be placed at the current time location.

NOTE

The first track number marker is created automatically at the beginning of the song (00h00m00s00). Audio CD specifications require that a song be at least four seconds in duration. For this reason, track number markers must be placed four seconds apart. If you attempt to place a marker within four seconds of another marker, "Can't Set Marker" will be displayed and the marker will not be placed.



For details refer to "Setting Edit Points Using Preview" (Owner's Manual p.162) and "Setting Edit Points Using Scrub" (Owner's Manual p.163).

Assigning Track Numbers

When you write an audio CD, a track number will automatically be assigned to "00h00m00s00f." For this reason, the track number markers and the actual song order will be as follows.

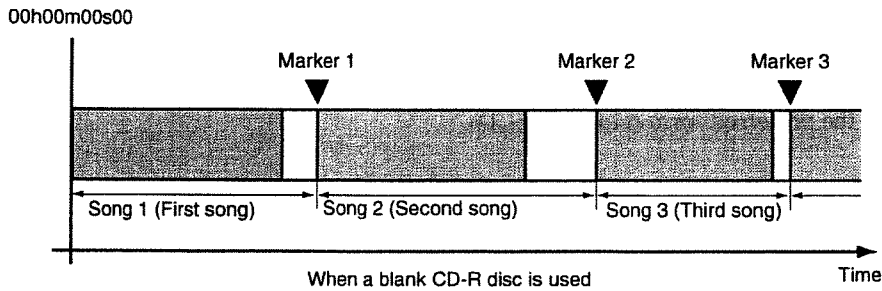

If you write additional songs onto a CD-R disc to which songs have already been written, track numbers will be assigned in sequence to follow the previously-written songs. For example if five songs have already been written to the CD-R disc, the next song you write will be song number six.

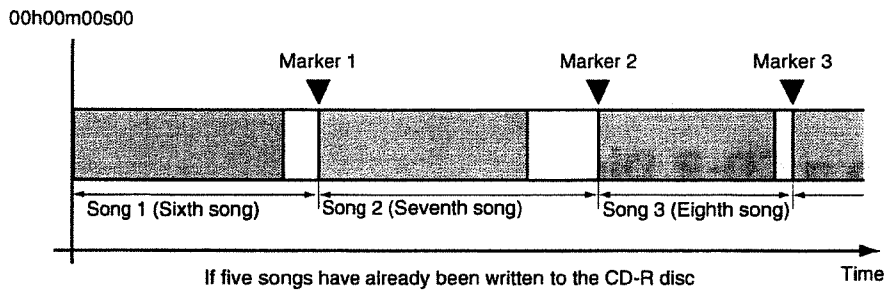

Creating an Original Audio CD

This chapter explains how you can create an original audio CD by recording two tracks (stereo tracks) from the VS-1880 to the Roland CD recorder.



In order to create an original audio CD, you will need the Roland CD recorder (sold separately).

Connecting the CD-R Drive/CD-RW Drive

A CD-R/CD-RW drive allows you to use CD-R or CD-RW discs to create audio CDs. CD-R discs are the preferred format for audio CDs.

- 1 Make sure that the power of all devices is turned off.
- 2 Use a SCSI cable to connect the Roland CD recorder.
- 3 Turn on the power of the Roland CD recorder.
- 4 Turn on the power of the VS-1880.

Writing a Song to a CD-R Disc

When this procedure is performed, the VS-1880 will first create a CD-R image file on its internal hard disk, and will then write that image file to the CD-R disc. For this reason, there must be sufficient free space on the internal hard disk to create this image file.

All unused capacity of the hard disk will be allocated to the image file, regardless of the partition settings. The image file will be deleted automatically after it has been written to the CD-R disc.



Because image date is not created in situations involving specified tracks of a song when the recording mode is CDR mode, or V tracks recorded on a mastering track in CDR mode, the time it takes to write to the CD-R disc can be reduced.

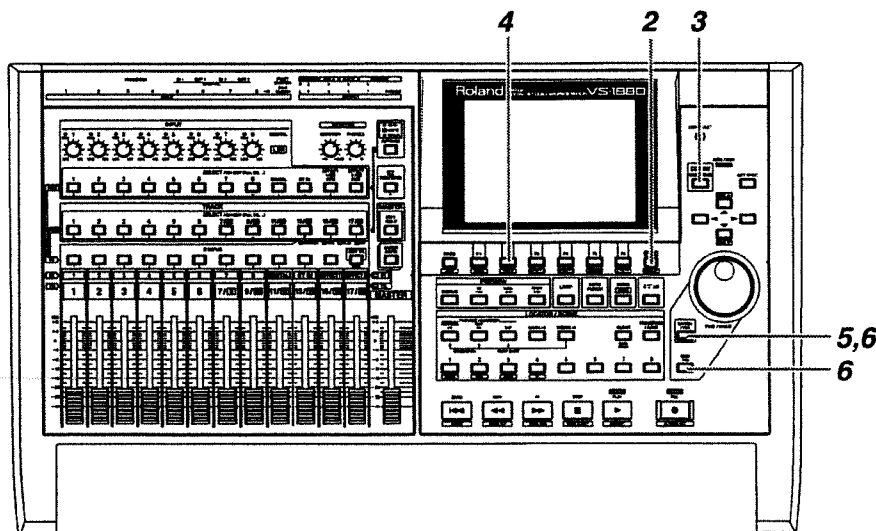

Creating an Original Audio CD

- 1 Insert an unused CD-R disc into the Roland CD recorder.
- 2 Press [PLAY (DISPLAY)].
- 3 Press [CD-RW (MASTERING)].



Audio CD's created using a CD-RW disc cannot be played (heard) on a conventional CD player. Please use a CD-R disc for this example.

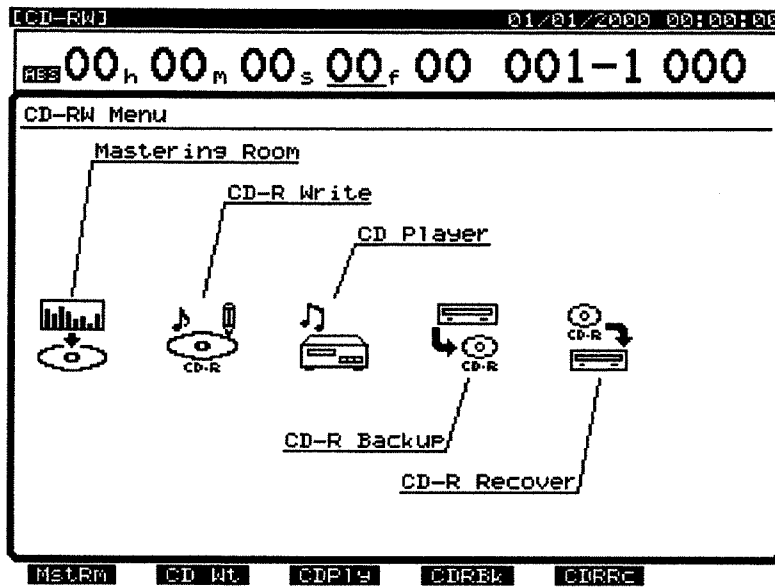

- 4 Press [F2 (CD Wt)].
- 5 A message will ask you to confirm. Press [YES].
- 6 The display will ask "STORE Current?" (Store the current song?) If you wish to store the current song before you write the CD, press [YES]. If not, press [NO].

Creating an Original Audio CD

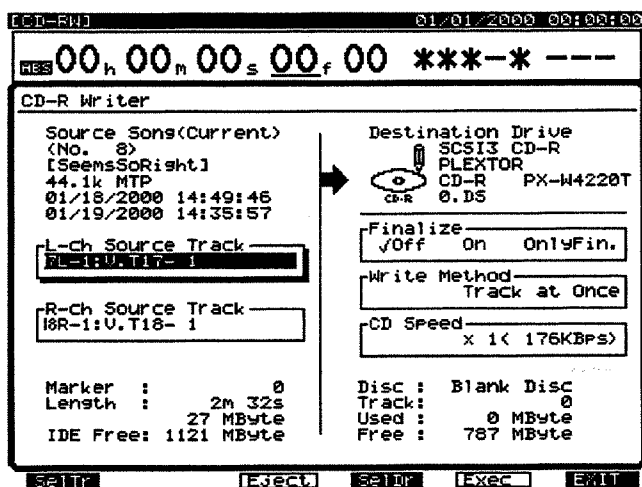
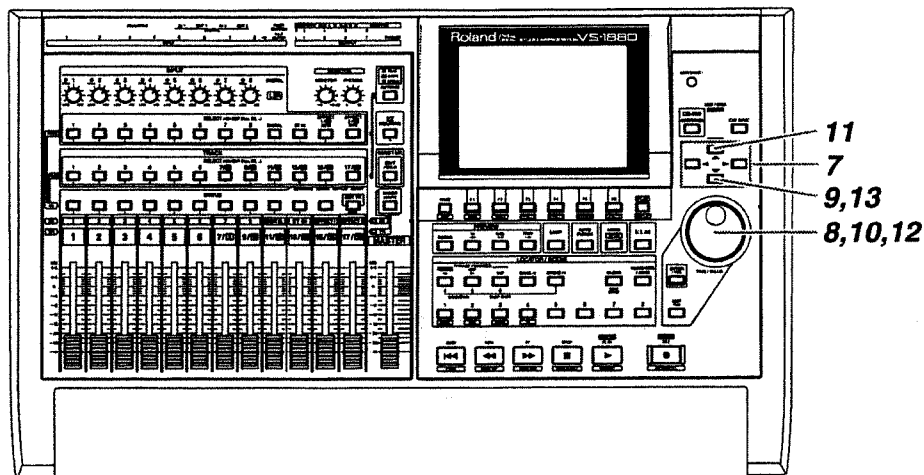

- 7** Use [**▲**] [**▼**] [**◀**] [**▶**] to move the cursor to "L-ch Source Track."
- 8** Use the TIME/VALUE dial to select the track that you wish to write as the Left track of the CD. For this example, select V-track 1 of track 7 (7-1).
- 9** Press [**▼**]. The cursor will move to "R-ch Source Track."
- 10** Use the TIME/VALUE dial to select the track that you wish to write as the Right track of the CD. For this example, select V-track 1 of track 8 (8-1).

11 Press [▶]. The cursor will move to "Finalize."

12 Use the TIME/VALUE dial to specify whether or not to finalize the CD-R disc after writing the song. For this example, select "Off."

Finalize

"Finalize" means to write the TOC (Table Of Contents) to the audio CD created by the VS-1880.

If a CD-R disc has not been finalized, additional songs can be written to the unused area of that disc. However, such a disc cannot be played back on a conventional CD player. An unfinalized CD-R disc can be auditioned using the VS-1880's CD Player function.

A finalized CD-R disc can be played back on a conventional CD player in the same way as a commercial pre-recorded audio CD. However it will no longer be possible to record additional songs, even if there is unused space on that disc.



Finalize (Appendices p.12)
TOC (Appendices p.13)

13 Press [▼]. The cursor will move to "Write Method."

Creating an Original Audio CD

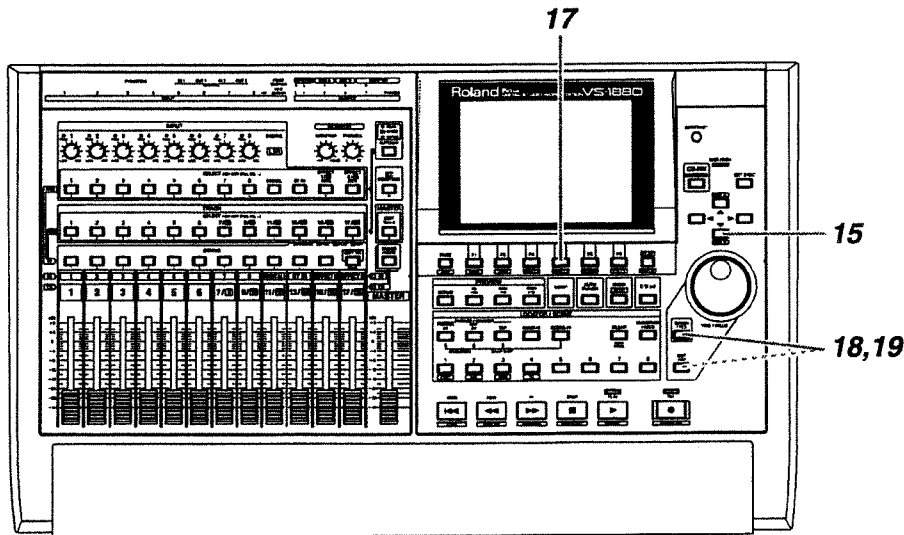

14

When two or more songs are written to the disc at the same time, select how the data will be written.

Disc at Once: The song data and the track number markers attached to the song data will be written to the CD-R disc without change. However, **additional song data cannot be added later to a CD-R disc that was written using Disc at Once. (It will be in the same condition as if Finalize had been performed.)**

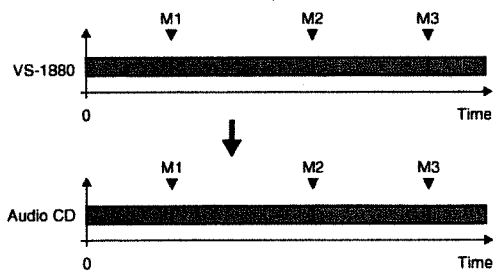

Track at Once: Two seconds of silence will automatically be written to the CD-R disc before each track number marker attached to the song data. (This is the same condition as when additional songs are written to the disc later.) Additional song data can be written to a CD-R disc that was written using Track at Once.

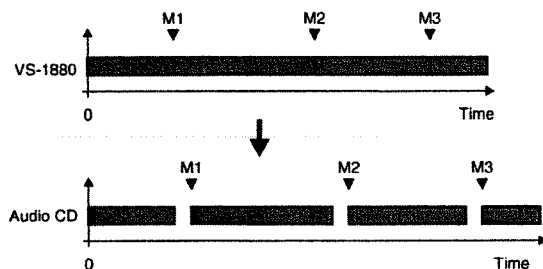

15 Press [▼]. The cursor will move to “CD Speed.”

16 Select the speed at which the song will be written to the CD-R disc.

x4 (704 KBps): The song will be written at quad speed (704 kilobytes per second).

x2 (353 KBps): The song will be written at double speed (353 kilobytes per second).

x1 (176 KBps): The song will be written at normal speed (176 kilobytes per second). This will provide higher reliability.

17 Press [F4 (Exec)]. A message will ask you to confirm.

18 Press [YES]. A message with license agreement will appear. Please read the message carefully, and if you accept the agreements, press [YES]. The VS-1880 will begin writing to the CD-R disc. If you do not accept the agreements, press [NO]. You will return to step 2.

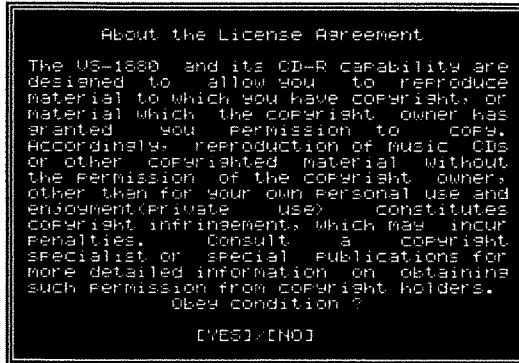

19 When the data has been written, the display will ask “Write Another?” (Write another disc?) If you wish to write the same song data to another CD-R disc, insert the new disc into your CD-R drive, and press [YES]. If you press [NO] you will return to step 2.



If you're using a CD-RW disc in a CD-RW drive, do not choose a selection other than x2 (352 KBps).

Auditioning the Song You Wrote

The CD-R disc to which you just wrote a song (an unfinalized CD-R disc) cannot be played back in its current condition on a commercial CD player. To check (audition) the song you wrote to the disc, use the following procedure.

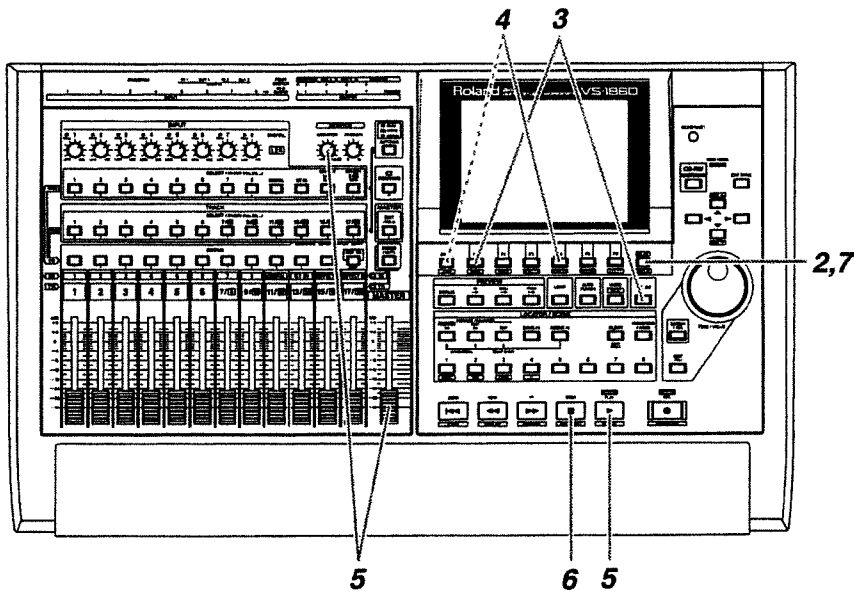

- 1 Insert the CD-R disc into the CD-R drive.
- 2 Press [PLAY (DISPLAY)].
- 3 Press [CD-RW (MASTERING)].

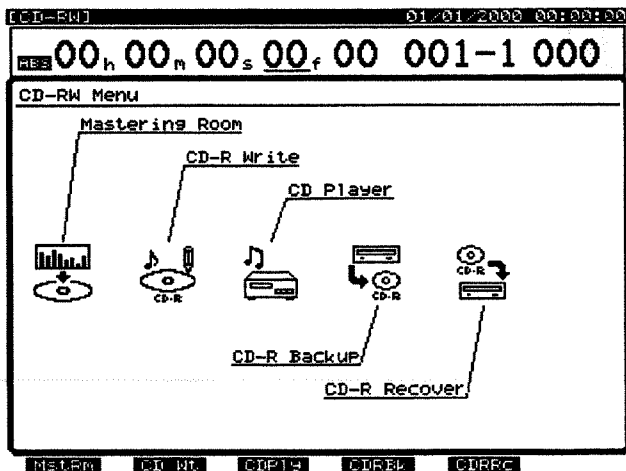

Creating an Original Audio CD

4

Press [F3 (CDPlay)].

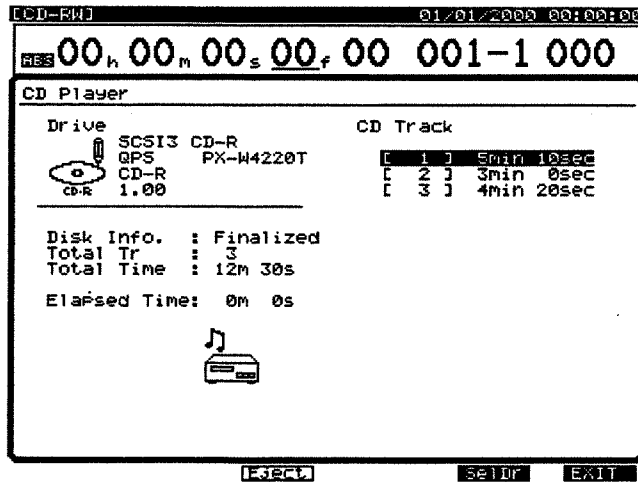

5

Press [PLAY]. The CD will begin playing back. Use the master fader and the MONITOR knob to adjust the volume to a convenient listening level. At CD Player function, only the following buttons, knobs, and faders will be active.

[ZERO]: Move to the beginning of the first song.

[REW]: Rewind as long as you continue to press the button.

[FF]: Fast-forward as long as you continue to press the button.

[STOP]: Stop.

[PLAY]: Begin playback from the current location.

[PREVIOUS] or [▲]: Return to the previous song.

[NEXT] or [▼]: Advance to the next song.

Master fader: Adjust the overall volume.

MONITOR knob: Adjust the volume of the MONITOR jacks.

PHONES knob: Adjust the volume of the headphones.

6

When you are finished playing back, press [STOP].

7

Press [PLAY (DISPLAY)]. You will return to the display from which you began the procedure.



You can listen to the contents of the disc only through the VS-1880's MASTER output, MONITOR output, or from the PHONES jack. You cannot output the audio from the CD-R/CD-RW headphone jack or AUDIO OUT jacks.



Audio CD's created using a CD-RW disc cannot be played (heard) on a conventional CD player.



[REW], [FF] buttons active when be stopping.

Index

Numerics

1/4 inch phone jack 38

A

acoustic feedback 39
After Rec 116
after recording 116
audio CD 35, 101, 128–130

C

calendar 17
Canceling 47
CD player 136
CD Player function 133
CD Speed 135
CD-R
 disc 108, 128–130, 134–136
 drive 5, 128, 130, 135–136
CD-R recording mode 116
CDRRecMode 116
CD-RW
 drive 5, 130
Channel Link 106
condenser mic 39
CONTRAST knob 15
current song 19

D

date 16
Date Edit 17
Date Format 18
delay 74
Demo Song 21
Disc at Once 134
Display Contrast 15
Drive Initialize 70
dynamic mic 39

E

effect expansion board 5, 8, 73, 122
effect insert switch 124
Effect menu 75, 81, 84, 88, 93, 97, 103
effect return level 124
effect send level 124
effects 73
equalizer 67

F

Factory reset 15

Finalize 133–134
FXIns 116

G

GUITAR (Hi-Z) jack 41, 96
Guitar Multi 92

H

HDP88 series 5
headphones 5, 13, 25

I

icon 28
IDE 5
image file 130
Initialize 70
INPUT jacks 38
Input Mixer display 96
Input Sensitivity 40
Insertion Type 92, 95–96
Internal Battery 18
internal clock 16

L

level meter 22–23
license agreement 135
Link 106
lithium battery 9
Locator 109

M

marker 115, 128
MASTER jacks 13
mastering track status 115
mastering track switch 115
Mic Simulator 92
Microphone 38
MIX 65
mixdown 114
mixed down 101
Mixer
 initialization 15
MONITOR
 jacks 13
 knob 21, 25, 41, 137
Multi-Track Recording 33

N

No Effect Board 10, 13, 73
Not Found any Drives 14

- O**
 Overdubbing 61
- P**
 Pan 65
 parameter view 66
 parametric equalizer 67
 partition 33, 70, 130
 phantom power 39
 PHONES
 jack 13
 knob 22, 25
 play back 44
 playlist 22, 121
 Post Level 24
 POWER switch 14, 20
 Pre Level 24
 Preview function 128
 Punch-In 50
 punch-in recording 50
 Punch-Out 50
- R**
 recording 42
 Recording mode 114
 recording mode 36
 Redo 47, 49
 Remaining Time 45
 reverb 74, 78, 86
- S**
 sample rate 35
 Sampling rate 114
 Scene 26
 Scrub function 128
 Send/Return Type 74, 78, 86, 95
 Shutdown 19
 song end 108
 Song Erase 30
 Song menu 27, 30, 34, 55
 Song Name 35
 Song New 34
 Song Optimize 55
 Song Protect 33
 Song Select 27
 Song Store 69
 Stereo Position 65
 STORE Current? 20
- Surface Scan 72
 System initialization 15
 System Menu 16
- T**
 Table Of Contents 133
 time 16
 Time Available for Recording 45
 Time Edit 18
 time stamp 16
 TOC 133
 Tone 67
 Track at Once 134
 Track Bouncing 101
 Track Cut 108
 Track Edit menu 52, 110, 112
 Track Erase 52
 Track Mixer 57, 59
 Track Mixer display 65, 102, 105
 Track Number Marker 128
 Track number marker 115
 Track Numbers 129
- U**
 Undo 47–48
 Undo Level 47
 Utility menu icons 70
- V**
 V.Trk 115
 Vocal Multi 92
 Volume Balance 64
 VS-1880 5
 VS8F-2 5, 8, 73, 122
 V-Track 57, 59, 115
- W**
 Write Method 133
- X**
 XLR connector 38
 XLR type pin wiring 39

Roland®

71671189

UPC

71671189



18991