

# SMALL BAT HOUSE

## LUMBER:

4' X 4' X 1/2" CDX EXTERIOR PLYWOOD  
1" X 4" X 6' BOARD

OTHER TOOLS AND SUPPLIES NEEDED  
ARE SAME AS THOSE FOR THE  
STANDARD SIZE BAT HOUSE.

## ASSEMBLY INSTRUCTIONS:

Bat roosting requirements are strict, necessitating adherence to construction details.

1. Cut out parts as illustrated.
2. Apply a bead of caulk to front edges of box SIDES & attach box FRONTS with 6-8 screws per side. Clean excess caulk that squeezes out.
3. Score inside of front and sides with utility knife to roughen. Also score bottom 5.5" on outside of box FRONT below vent. Make horizontal scratches 1/4" apart. While the knife is out, score both sides of ROOSTING BAFFLES and the interior side of box BACK. These are landing / roosting footholds and are VERY IMPORTANT. Do not use saw to roughen, this will cause plywood to delaminate.

## LANDING PLATE AND INTERIOR SURFACES MUST BE ROUGHENED.

4. Attach 2 BAFFLE SPACERS to inside front corners with two screws each, and screwed in from front of box. Space about 2 inches from top of box FRONT with 3/4" dimension to sides. Lay assembled parts FRONT down on table or floor.
5. Attach ROOST BAFFLE to spacers about 1" down from top of sides. Use 2 screws on each side.
6. Attach two BAFFLE SPACERS into new corners made by short roost baffle. Use 2 screws on each side.
7. Attach ROOST BAFFLE to spacers about 1" down from top of sides. Use four screws on each side.
8. Caulk back edges of box SIDES and attach box BACK with scored side in. Do not caulk inside vent areas. The BACK should extend 2" above top of SIDES. Use 6-8 screws on each side. Clean excess caulk that should squeeze out.
9. Center ROOF SUPPORT on inside top of box FRONT. Align angled edge with top edge of FRONT and SIDES. Attach with 3 screws through the box FRONT.
10. Center ROOF SUPPORT on inside and 2" below top of box BACK. Align angled edge with top edges of SIDES. Attach with 3 screws through box BACK.
11. Apply bead of caulk to top of SIDES, FRONT, two ROOF SUPPORTS and angled back edge of ROOF.
12. Lay ROOF in position and attach with at least three screws on each SIDE, FRONT and BACK. Clean excess caulk.
13. Caulk back of roof top where it butts against the back. Smooth with damp towel. Inspect all other caulked seams and caulk exterior seams as necessary.
14. Apply two to three coats of stain to exterior, including the landing plate.
15. Cut section of black rolled roofing to fit on roof top. Apply thin bead of caulk around top of roof edges. Set rolled roofing into position and staple down. Caulk back edge of rolled roofing where it butts against box BACK. Caulk exposed staples on rolled roofing surface.
16. Cut out piece of fiberglass window screening to fit on landing plate to provide a good landing platform. Staple to bottom front of box BACK. Coat exposed staples with black stain. Landing plate should be roughened under screening since screening may eventually fall off.

Maximum Capacity: 80 Bats

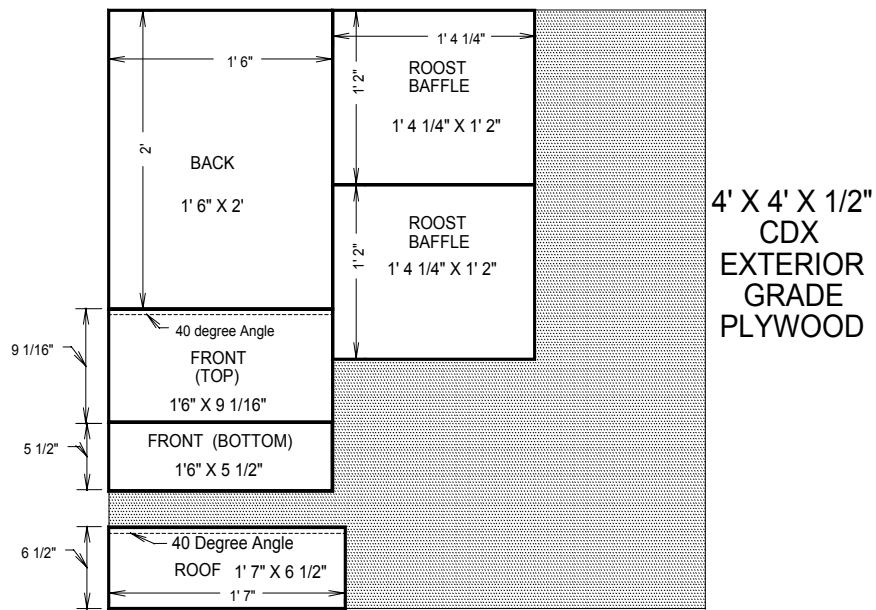
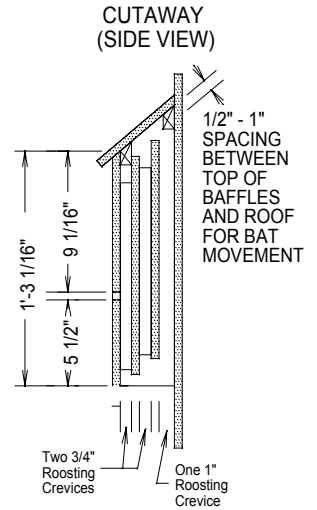
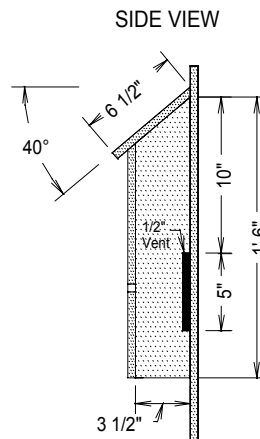
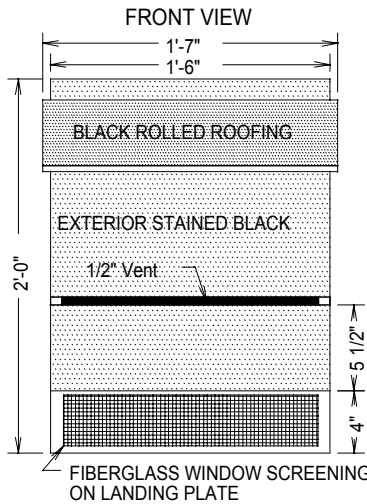
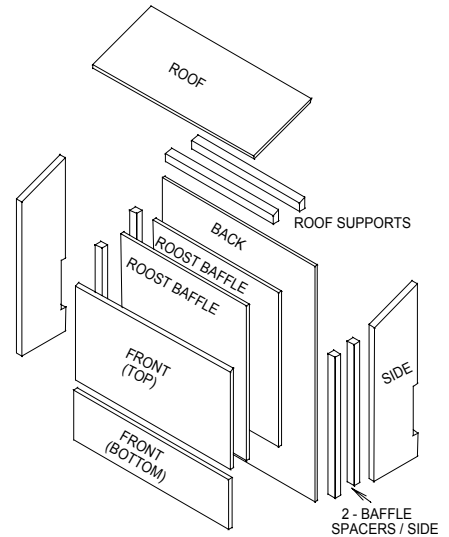
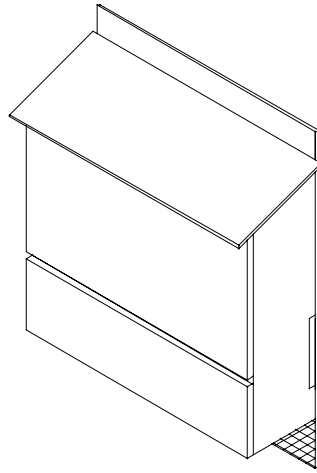

## 1" X 4" X 6' BOARD

